



David J. Johnson
 Director
 Service Engineering Operations
 Ford Customer Service Division

Ford Motor Company
 P. O. Box 1904
 Dearborn, Michigan 48121

May 12, 2021

TO: All U.S. Ford and Lincoln Dealers

SUBJECT: NEW VEHICLE DEMONSTRATION / DELIVERY HOLD -

Safety Recall 20S42 – Supplement #1

Certain 2015-2018 Model Year Edge and 2016-2018 Model Year Lincoln MKX Vehicles
 Front Brake Flexible Hose Leaks

REF: Safety Recall 20S42

Certain 2015-2018 Model Year Edge and 2016-2018 Model Year Lincoln MKX Vehicles
 Dated: April 15, 2021

New! REASON FOR THIS SUPPLEMENT

- **Parts List:** An equivalent brake fluid may be used (which meets the Ford DOT4 PM-20 specification) to complete this service repair if PM-20 is on back-order.
- **Replaced FSA Parts Inspection and Sign Off:** New Policy
- **Parts Retention, Return, & Scrapping:** Updated Policy

AFFECTED VEHICLES

Vehicle	Model Year	Assembly Plant	Build Dates
Edge	2015-2018	Oakville	June 25, 2014 through December 21, 2017
MKX	2016-2018	Oakville	November 11, 2014 through December 21, 2017

Affected vehicles are identified in OASIS and FSA VIN Lists.

REASON FOR THIS SAFETY RECALL

In some of the affected vehicles, brake fluid may leak from one or both front brake flexible hoses. If the brake fluid reservoir is depleted below a predetermined level, the brake fluid warning indicator light will illuminate. The driver may experience an increase in pedal travel together with a reduction in the rate of deceleration, increasing the risk of a crash.

SERVICE ACTION

Before demonstrating or delivering any new in-stock vehicles involved in this recall, dealers are to replace both front brake flexible hoses and perform a brake system bleed. This service must be performed on all affected vehicles at no charge to the vehicle owner.

OWNER NOTIFICATION MAILING SCHEDULE

Parts available owner letters are expected to be mailed the week of May 3, 2021. Dealers should repair any affected vehicles that arrive at their dealerships, whether or not the customer has received a letter.

PLEASE NOTE:

Federal law requires dealers to complete this recall service before a new vehicle is delivered to the buyer or lessee. Violation of this requirement by a dealer could result in a civil penalty of up to \$21,000 per vehicle. Correct all vehicles in your new vehicle inventory before delivery.

New! ATTACHMENTS

Attachment I: Administrative Information
Attachment II: Labor Allowances and Parts Ordering Information
Attachment III: Technical Information
Attachment IV: Template
Owner Notification Letters
Recall Reimbursement Plan

QUESTIONS & ASSISTANCE

For questions and assistance, contact the Special Service Support Center (SSSC) via the SSSC Web Contact Site. The SSSC Web Contact Site can be accessed through the Professional Technician Society (PTS) website using the SSSC link listed at the bottom of the OASIS VIN report screen or listed under the SSSC tab.

Sincerely,



David J. Johnson

NEW VEHICLE DEMONSTRATION / DELIVERY HOLD -

Safety Recall 20S42 – *Supplement #1*

Certain 2015-2018 Model Year Edge and 2016-2018 Model Year Lincoln MKX Vehicles
Front Brake Flexible Hose Leaks

OASIS ACTIVATION

OASIS was activated on August 11, 2020.

FSA VIN LISTS ACTIVATION

FSA VIN Lists were available through <https://web.fsavinlists.dealerconnection.com> on August 11, 2020. Owner names and addresses were available on September 29, 2020.

NOTE: Your FSA VIN Lists may contain owner names and addresses obtained from motor vehicle registration records. The use of such motor vehicle registration data for any purpose other than in connection with this recall is a violation of law in several states, provinces, and countries. Accordingly, you must limit the use of this listing to the follow-up necessary to complete this recall.

SOLD VEHICLES

- Ford has not issued instructions to stop selling/delivering or driving used vehicles under this safety recall. Owners should contact their dealer for an appointment to have their vehicles remedied as soon as practicable. Owners can continue to safely drive their vehicles.
- Immediately contact any of your affected customers whose vehicles are not on your VIN list but are identified in OASIS. Give the customer a copy of the Owner Notification Letter (when available) and schedule a service date.
- Correct other affected vehicles identified in OASIS which are brought to your dealership.
- Dealers are to prioritize repairs of customer vehicles over repairs of new and used vehicle inventory.

STOCK VEHICLES

- Correct all affected units in your new vehicle inventory before delivery.
- Use OASIS to identify any affected vehicles in your used vehicle inventory.

DEALER-OPERATED RENTAL VEHICLES

The Fixing America's Surface Transportation (FAST) Act law effective June 2016 prohibits a rental company from selling, renting or leasing vehicles subject to a safety or compliance recall. Please consult your legal counsel for legal advice.

TITLE BRANDED / SALVAGED VEHICLES

Affected title branded and salvaged vehicles are eligible for this recall.

**NEW VEHICLE DEMONSTRATION / DELIVERY HOLD -
Safety Recall 20S42 – Supplement #1**
Certain 2015-2018 Model Year Edge and 2016-2018 Model Year Lincoln MKX Vehicles
Front Brake Flexible Hose Leaks

OWNER REFUNDS

- **This safety recall must still be performed, even if the owner has paid for a previous repair. Claiming a refund will not close the recall on the vehicle.**
- Ford Motor Company is offering a refund for owner-paid repairs covered by this recall if the repair was performed prior to the date indicated in the reimbursement plan, which is posted with this bulletin. Owners are directed to seek reimbursement through authorized dealers or, at their option, directly through Ford Motor Company at P.O. Box 6251, Dearborn, MI 48121-6251.
- Dealers are also pre-approved to refund owner-paid emergency repairs that were performed away from an authorized servicing dealer after the end date specified in the reimbursement plan. Non-covered repairs, or those judged by Ford to be excessive, will not be reimbursed.
- Refunds will only be provided for the cost associated with front brake flexible hoses with a base part number of 2078.

RENTAL VEHICLES

- Rental vehicles are not approved for this program.
- Ford has not issued instructions to stop selling/delivering or driving used vehicles under this safety recall. Owners can continue to safely drive their vehicles.
- Part shortages do not qualify for rental vehicles for this program.

LINCOLN PICKUP AND DELIVERY

- Owners of 2017 MY and newer Lincoln vehicles have the option of requesting pickup and delivery service with a Lincoln loaner (up to 2 days), from their dealership. For details, reference EFC08708, 2021 Lincoln Pickup & Delivery Updates.

NEW VEHICLE DEMONSTRATION / DELIVERY HOLD -**Safety Recall 20S42 – Supplement #1**

Certain 2015-2018 Model Year Edge and 2016-2018 Model Year Lincoln MKX Vehicles
Front Brake Flexible Hose Leaks

ADDITIONAL REPAIR (LABOR TIME AND/OR PARTS)

Additional repairs identified as necessary to complete the FSA should be managed as follows:

- For related damage and access time requirements, refer to the Warranty and Policy Manual / Section 6 – Ford & Lincoln Program Policies / General Information & Special Circumstances for FSA's / Related Damage.
- For vehicles within new vehicle bumper-to-bumper warranty coverage, no SSSC approval is required, although related damage must be on a separate repair line with the "Related Damage" radio button checked.
 - Ford vehicles – 3 years or 36,000 miles
 - Lincoln vehicles – 4 years or 50,000 miles
- For vehicles outside new vehicle bumper-to-bumper warranty coverage, submit an Approval Request to the SSSC Web Contact Site prior to completing the repair.

CLAIMS PREPARATION AND SUBMISSION

- **Claim Entry:** Enter claims using Dealer Management System (DMS) or One Warranty Solution (OWS) online.
 - When entering claims, select claim type 31: Field Service Action. The FSA number (20S42) is the sub code.
 - For additional claims preparation and submission information, refer to the Recall and Customer Satisfaction Program (CSP) Repairs in the OWS User Guide.
- **Related Damage/Additional labor and/or parts:** Must be claimed as Related Damage on a separate repair line from the FSA with same claim type and sub code as described in Claim Entry above.

IMPORTANT: Click the Related Damage Indicator radio button.
- **Refunds:** Submit refunds on a separate repair line.
 - Program Code: 20S42 - Misc. Expense: ADMIN
 - Misc. Expense: REFUND - Misc. Expense: 0.2 Hrs.
 - Multiple refunds should be submitted on one repair line and the invoice details for each repair should be detailed in the comments section of the claim.
- **Lincoln Pickup & Delivery:** Claims for Lincoln Pickup & Delivery with a Lincoln loaner (up to 2 days) should be submitted on a separate line from the FSA. Refer to EFC08708, 2021 Lincoln Pickup & Delivery Updates for details.

NEW VEHICLE DEMONSTRATION / DELIVERY HOLD -**Safety Recall 20S42 – Supplement #1**

Certain 2015-2018 Model Year Edge and 2016-2018 Model Year Lincoln MKX Vehicles
Front Brake Flexible Hose Leaks

LABOR ALLOWANCES

Description	Labor Operation	Labor Time
Replace both front flexible brake hoses (includes brake system bleed)	20S42B	1.0 Hours

New! PARTS REQUIREMENTS / ORDERING INFORMATION

Part Number	Description	Order Quantity	Claim Quantity
J2GZ-2078-A	RH Front Brake Flexible Hose	1	1
J2GZ-2078-B	LH Front Brake Flexible Hose	1	1
PM-20 Or OSP	Brake Fluid, 1 Pint Bottle <i>If PM-20 is back-ordered, an equivalent may be used if it meets the Ford DOT4 brake fluid specification number: WSS-M6C65-A2 and ISO4925 Class 6</i>	<i>As Required (up to a quantity of 1, not to exceed total cost of \$20)</i>	
W711784-S300	Washer (4 per vehicle, 2 each side)	4	4

Order your parts through normal order processing channels. To guarantee the shortest delivery time, an emergency order for parts must be placed.

DEALER PRICE

For latest prices, refer to DOES II.

New! PARTS RETENTION, RETURN, & SCRAPPING

Follow the provisions of the Warranty and Policy Manual, Section 1 - WARRANTY PARTS RETENTION AND RETURN POLICIES. If a replaced part receives a scrap disposition, the part must be scrapped in accordance with all applicable local, state and federal environmental protection and hazardous material regulations. Federal law prohibits selling motor vehicle parts or components that are under safety, compliance, or emissions recall.

EXCESS STOCK RETURN

Excess stock returned for credit must have been purchased from Ford Customer Service Division in accordance with Policy Procedure Bulletin 4000.

**NEW VEHICLE DEMONSTRATION / DELIVERY HOLD -
Safety Recall 20S42 – Supplement #1**
Certain 2015-2018 Model Year Edge and 2016-2018 Model Year Lincoln MKX Vehicles
Front Brake Flexible Hose Leaks

New REPLACED FSA PARTS INSPECTION AND SIGN OFF

Effective March 1st 2021 all parts replaced as part of an FSA repair with a repair order open date of March 1st 2021 or later must be inspected and signed off on the repair order by a member of your dealers fixed operations management team or an employee the task has been delegated to. If the task is to be delegated to a non-management employee, the employee needs to be someone other than the technician who completed the repair and needs to understand the importance of completing this task consistently and accurately.

- All parts replaced as part of an FSA repair should be returned to the parts department following the Warranty Parts Retention and Return Policies.*
- Inspect the replaced parts to verify the FSA repair was completed.*
- If the FSA repair is found to be complete, the designated employee signs the repair order line or parts return stamp area (electronic or hand signed) for the FSA repair indicating the parts were inspected and validated to have been replaced.*
- After the parts have been inspected, they should be handled based on the guidance in the parts status report in the Online Warranty System (Hold, Return, CORE, Scrap, etc.).*
- This process is subject to review during warranty audits for FSA repairs with a repair order open date of March 1st 2021 or later. Any eligible FSA claims requiring parts replacement, found not to have been inspected and signed off during a warranty audit will be subject to chargeback and consideration for enrollment into the Dealer Incomplete Recall Repair Process.*

Note: *Other approvals (electronic or handwritten) for add-on repair lines, dealer owned vehicle repairs, and repeat repairs do not qualify as FSA parts inspection approvals. The post repair FSA parts inspection process (electronic or handwritten) is independent from other warranty approval requirements. The approval by the designated employee implies that the FSA parts were found to be replaced and must be able to be clearly identified on the Repair Order. If multiple FSA's require approval on a single Repair Order, each applicable occurrence will require individual post repair approval by the designated employee.*

CERTAIN 2015-2018 MODEL YEAR EDGE, 2016-2018 MODEL YEAR MKX AND 2013-2017 FUSION VEHICLES — FRONT BRAKE FLEXIBLE HOSE REPLACEMENT

SERVICE PROCEDURE

For Edge and MKX Vehicles (For Fusion vehicles proceed to Page 2)

1. Replace the Right Hand (RH) and Left Hand (LH) front brake flexible hoses. Please follow the Workshop Manual (WSM) procedures in Section 206-03.

NOTE: It is not necessary to remove the rear wheels when bleeding the brake system.

NOTE: The wheel speed sensor wiring harness and if equipped, the front suspension height sensor wiring harness attach to the front brake flexible hose bracket. Ensure the harness retainer(s) are reinstalled into their original positions. See Figure 1.

NOTE: LH side shown, RH side similar.

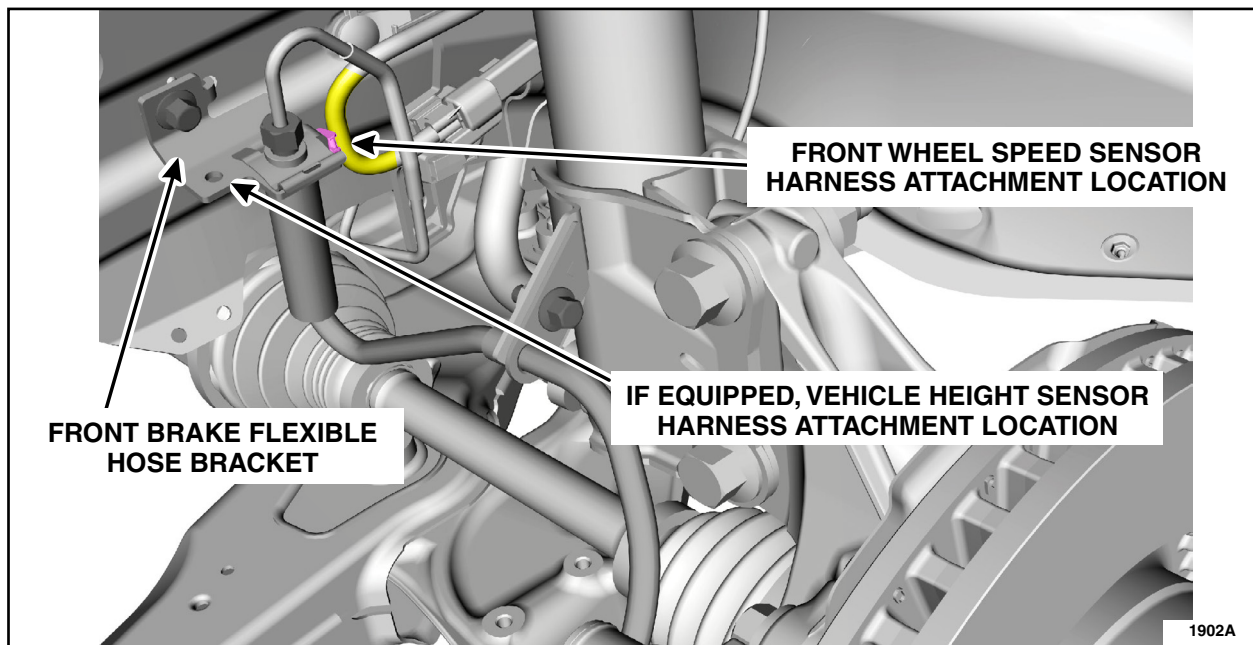

FIGURE 1



For Fusion Vehicles

1. Replace the RH and LH front brake flexible hoses. Please follow the Workshop Manual (WSM) procedures in Section 206-03.

- Do not reinstall the wheel and tire assemblies at this time, they will be installed later in this procedure.

Front Suspension Ride Height Sensor and Harness Re-routing, if equipped

1. Remove the wire harness retainer from the ride height sensor stud on the RH and LH sides of the vehicle. See Figure 1.

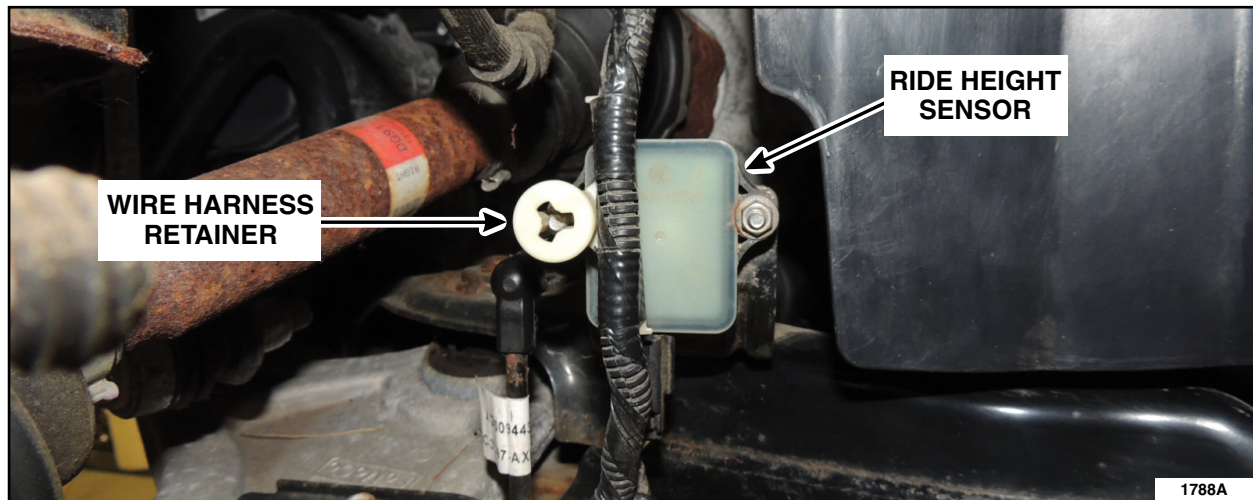

FIGURE 1

2. Remove the nuts and bolts from the RH and LH ride height sensors and position aside. See Figure 2.

3. Cut the RH and LH ride height sensors harness tape at the harness bend. See Figure 2.



FIGURE 2



4. Attach the cut out templates (See Attachment IV) to the RH and LH front fender splash shields. Using a suitable cutting tool, cut the front fender splash shields at the locations shown. See Figure 3.

- Remove any burrs or sharp edges.

NOTE: The front fender splash shields should remain on the vehicle during cutting.

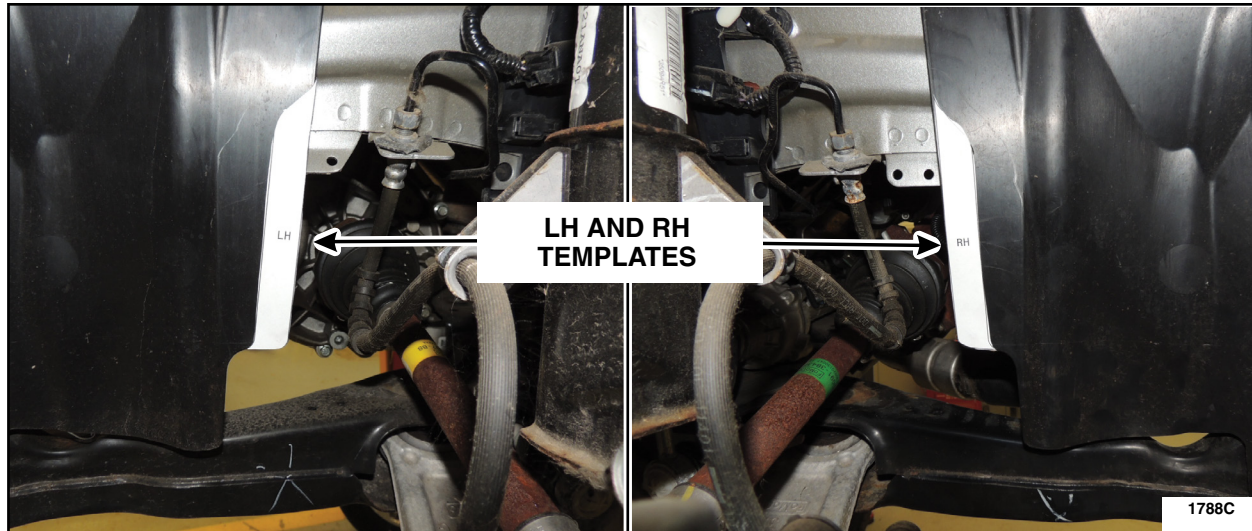

FIGURE 3

5. Position the RH and LH front ride height sensors back onto the brackets and install the nuts and bolts with the long bolt in the front bracket hole. See Figure 4.

- Tighten bolts to 7 lb.ft (9 Nm).

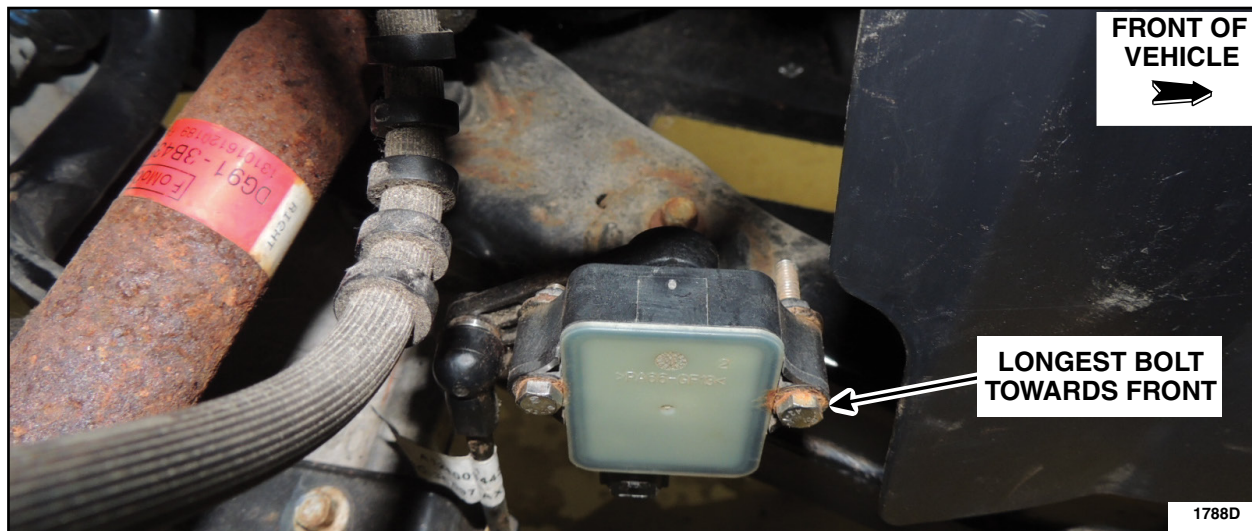

FIGURE 4



6. Mark the location of the RH and LH clip on the ride height sensors wire harness. See Figure 5.
7. Remove the tape and clip from the RH and LH ride height sensors wire harness. Rotate the clips 180 degrees and reinstall onto the ride height sensors wire harness with electrical tape. See Figure 5.

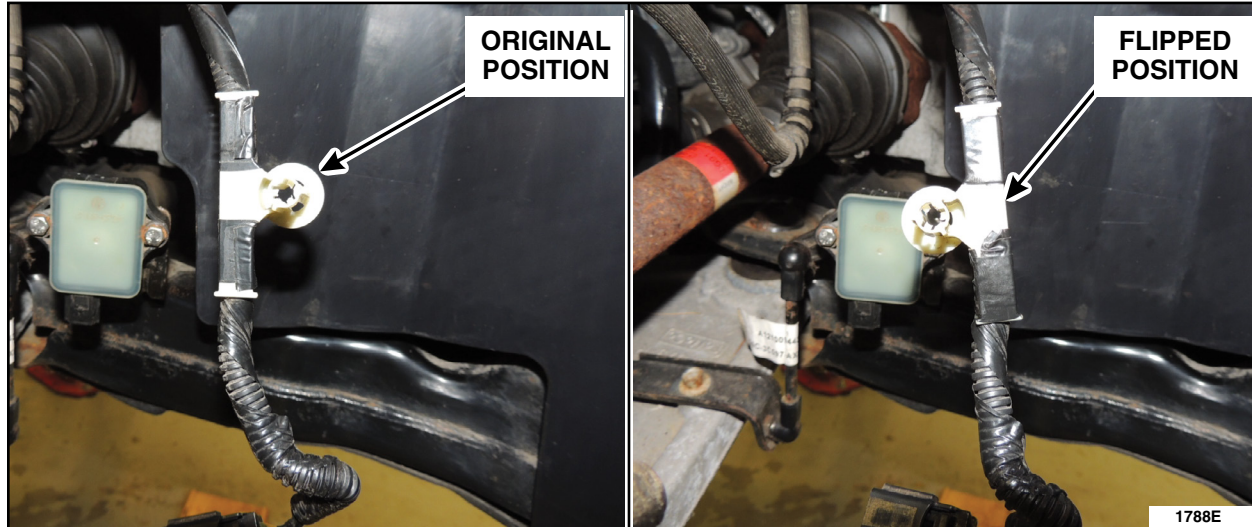

FIGURE 5

8. Attach the RH and LH ride height sensors wire harness clips to the front bracket bolt (long bolt) and secure the harness loop using electrical tape. See Figure 6.

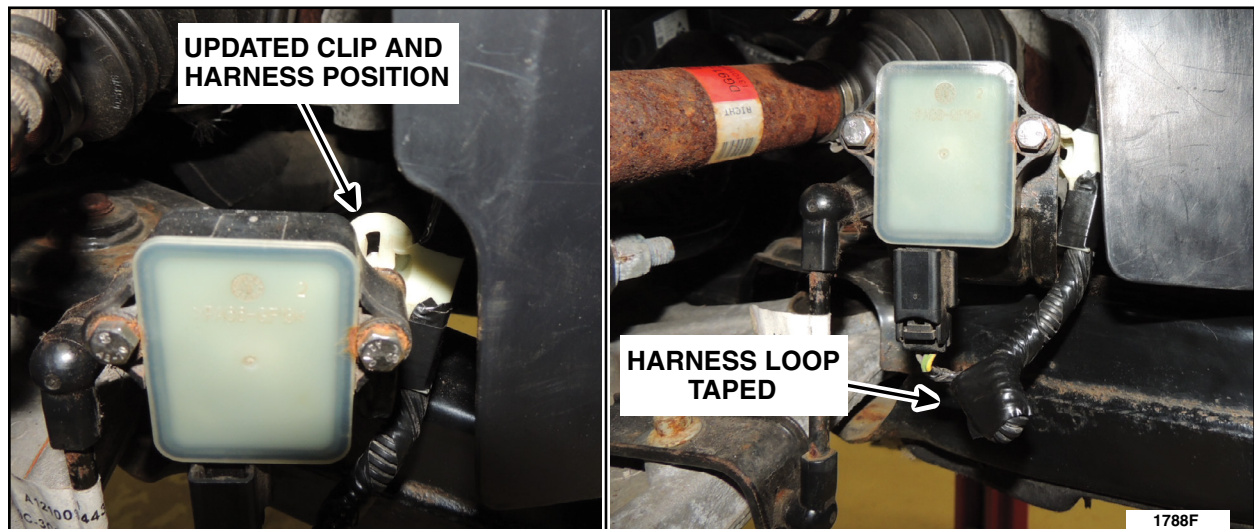

FIGURE 6

9. Reinstall both front wheel and tire assemblies, please follow the WSM procedures in Section 204-04A.
10. Calibrate the suspension height sensor. Connect the scan tool and carry out the Ride Height Calibration routine. Follow the scan tool directions.



Front Fender Splash Shield Templates - Fusion Vehicles

Printing Directions:

Print on 8.5" x 11" paper in portrait orientation only

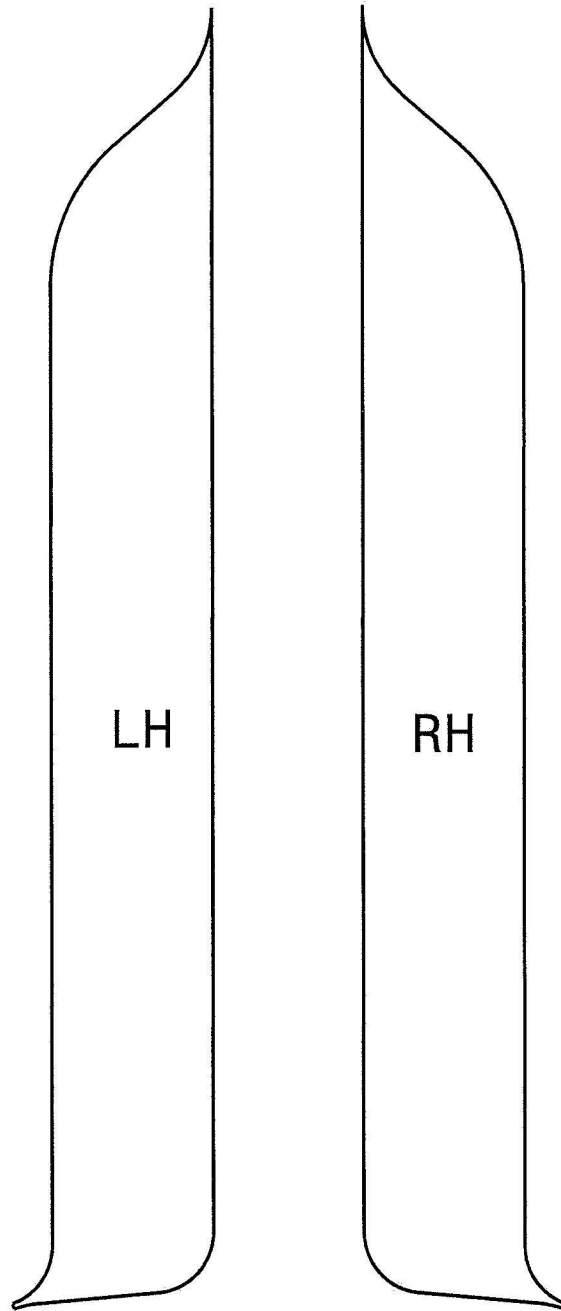

Ford Motor Company
Recall Reimbursement Plan for 20S42

Ford and Lincoln dealers are in the best position to quickly and efficiently process reimbursement requests. However, federal legislation requires all motor vehicle manufacturers to establish processes through which customers may seek recall reimbursement directly from the manufacturer or from the dealers.

Regarding the specific reimbursement plan for Recall # 20S42, owners who have paid for service to remedy the defect or noncompliance must have had that service performed prior to 5/31/2021. After this date, if repairs related to this recall are performed by a non-Ford repair facility in an emergency situation, customers must submit any refund requests through their dealership. As required by this federal regulation, Ford Motor Company submitted the details of its latest General Recall Reimbursement Plan in a letter to the National Highway Traffic Safety Administration (NHTSA) in February 2019. The following is the text of that letter and the Plan:

General Recall Reimbursement Plan
(As submitted to the NHTSA)

Pursuant to the requirements set forth in 49 CFR Part 573 and Part 577 of the Code of Federal Regulations, Ford Motor Company (Ford) is submitting required information pertaining to our general reimbursement plan for the cost of remedies paid for by vehicle owners before they are notified of a related safety recall.

Set forth below is Ford's general plan to reimburse owners and purchasers for costs incurred for remedies in advance of notification of potential safety related defects or noncompliance's pursuant to Part 573.6 (c)(8)(i). This plan has not changed since our February 20, 2019 submission.

Reimbursement Notification

Ford's notice to a vehicle owner in accordance with 49 CFR Part 577 will indicate that Ford is offering a refund if the owner paid to have service to remedy the defect or noncompliance prior to a specified ending date. In accordance with Part 573.13 (c)(2), this ending date will be defined as a minimum of ten calendar days after the date on which Ford mailed the last of its Part 577 notifications to owners, and will be indicated in the specific reimbursement plan available to owners for an individual recall. This notice will direct owners to seek eligible reimbursement through authorized dealers or, at their option, directly through Ford at the following address:

Ford Motor Company
P.O. Box 6251
Dearborn, MI 48121-6251

Ford notes that this rule allows for the identification of a beginning date for reimbursement eligibility. Under the rule, an owner who paid to remedy the defect or noncompliance prior to the identified beginning date would not be eligible for reimbursement. Ford generally has not established such a beginning date for reimbursement eligibility and does not presently anticipate changing this general policy. However, in any case where Ford determines a beginning date is appropriate, Ford will indicate that date in the owner notice. As permitted by 577.11(e), Ford may not include a reimbursement notification when all vehicles are well within the warranty period, subject to approval by the agency.

Costs to be Reimbursed

For vehicles, reimbursement will not be less than the lesser of:

- The amount paid by the owner for the remedy that specifically addressed and was reasonably necessary to correct the defect or noncompliance that is the subject of the recall, or
- The cost of parts for the remedy (to be no more than the manufacturer's list retail price for authorized part(s), plus associated labor at local labor rates, miscellaneous fees (such as disposal of waste) and taxes.

For replacement equipment, reimbursement will be the amount paid by the owner for the replacement item (limited by the amount of the retail list price of the defective or noncompliant item that was replaced, plus taxes, where the brand or model purchased by the owner was different than the brand or model that was the subject of the recall). If the item of motor vehicle equipment was repaired, the reimbursement provisions identified above for vehicles will apply.

Ford notes that costs incurred by the owner within the period during which Ford's original or extended warranty would have provided for a free repair of the problem will not be eligible for reimbursement, as provided by Part 573.13 (d)(1).

Entities Authorized to Provide Reimbursement

Ford will continue to use authorized dealers to reimburse owners under the specific reimbursement plans for a particular recall and will encourage owners to pursue requests for reimbursement directly through dealers to expedite reimbursement. Ford will also provide a mailing address to which customers can, at their option, send requests for reimbursement directly to Ford, as previously noted. Requests for reimbursement sent directly to Ford may take up to 60 days to process. Whether the owner chooses to pursue reimbursement requests through a dealer or directly through Ford, the owner will be directed to submit the required documentation, upon which reimbursement eligibility will be determined.

Required Documentation

The reimbursement determination will depend upon the information provided by the customer. Consistent with Part 573.13 (d)(4) the following information must be submitted:

- Claimant name and address
- Vehicle make, model, and model year
- Vehicle identification number (VIN) and, for replacement equipment, a description of such equipment or, for tires, the model, size and TIN (DOT code)
- Identification of the recall number (either the Ford recall number or the NHTSA recall number)
- Identification of the owner of the recalled vehicle at the time that the pre-notification remedy was obtained
- An original receipt for the pre-notification remedy that includes a breakdown of the amount for parts, labor, other costs and taxes, including costs for the replacement item. Where the receipt covers work other than to address the recall or noncompliance, Ford may require the claimant to separately identify costs that are eligible for reimbursement.
- If the remedy was obtained during the warranty period, documentation indicating that the warranty was not honored, or the warranty repair did not correct the problem related to the recall.

Failure to submit all of the above information may result in denial of the reimbursement request.

Additional Information

The Part 577 required owner notice will provide a toll-free telephone number through which specific information about the reimbursement plan can be requested from Ford. This general reimbursement plan will be incorporated into notifications pursuant to Part 573.6 by reference. Information specific to an individual recall also may be incorporated into the Part 573.6 notification.