



# WARRANTY BULLETIN SAFETY CAMPAIGN

Can-Am® On-Road Ryker™

**⚠WARNING: All involved customers must be notified, all involved units must be corrected as per instruction herein.**

Campaign no.: 2019-0014  
2020-0001

**October 3, 2019**

Subject: **Wheel Nut May Crack**

No. **2020-1**

[▶New VINs added in the Warranty Campaign and New Steps in the Procedure◀](#)

**REVISION 1**  
[▶October 15, 2020◀](#)

[▶TEXT\(S\) BETWEEN ARROWS IS \(ARE\) MODIFIED ELEMENT\(S\) TO THE PREVIOUS PUBLICATION.◀](#)

MODEL YEAR	MODEL	ADMISSIBLE UNITS
2019 - 2020	Ryker®	Go to BOSSWeb/Warranty/Campaign Monitoring to know the quantity of units in your inventory impacted by this campaign

### IMPORTANT

- When a vehicle comes in for service, always type the VIN in Knowledge Center to check for pending campaigns or alerts.
- When performing any work on a vehicle, it is good practice to connect it to BUDS2 to ensure that all needed updates are done.



## PROBLEM

One or more wheel nuts may crack resulting in a reduced clamping force. This could eventually affect the integrity of the wheel assembly and the vehicle's behavior. This may increase the risk of a crash.

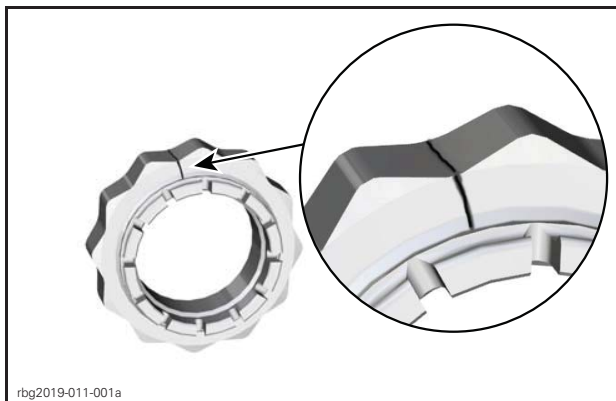

## SOLUTION

Replace all wheel nuts on the vehicle.

The improved nut has a pronounced groove on one of its edges.

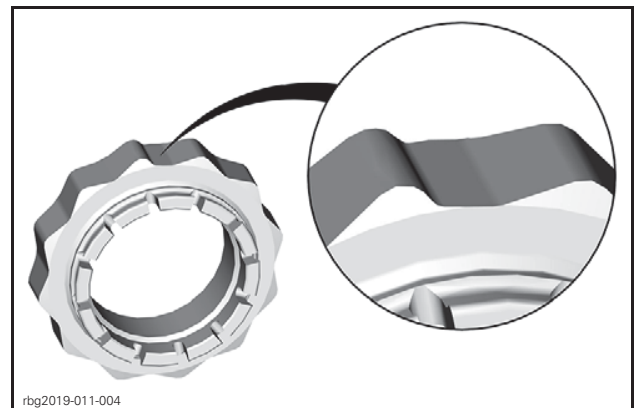

## PARTS REQUIRED



Order parts through regular channel.

Your order will be released progressively upon availability to ensure an even distribution across the network.

**NOTE:** Your order will be processed despite the message generated by selective release "No Availability Date at the Present Time" on BOSSWeb.

DESCRIPTION	PART NUMBER	QTY
Wheel nut	705402730	3

## MANDATORY TOOLS

REQUIRED TOOL	
65MM SOCKET (P/N 529 036 457)	
Calibrated torque wrench ranging up to 350 N•m (258 lbf•ft).*	
* Torque wrench calibration must be performed each year.	

## CORRECTIVE ACTION

▶ THE ADDITIONAL STEP TO THIS CORRECTIVE ACTION IS TO FILL IN THE MANDATORY CERTIFICATION FORM. New instructions are at the end of the CORRECTIVE ACTION. ◀

Before performing the procedure, it is strongly recommended to view the following video.



Wheel Nut Replacement Procedure - Help Video (Article #137066)

### Removing the Front Wheel Nut

1. Place the vehicle on a level surface.
2. Lift and support the front of the vehicle.

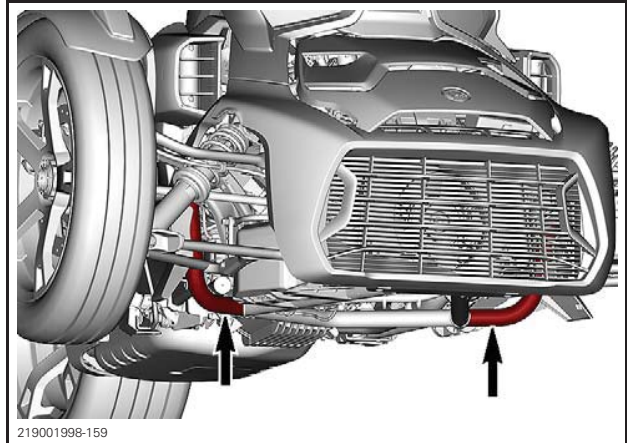

USE THESE TUBES TO LIFT OR SUPPORT THE FRONT OF THE VEHICLE

3. Turn the handlebar and lock the wheel hub with a locking device (such as a long Allen key or a tempered steel rod).

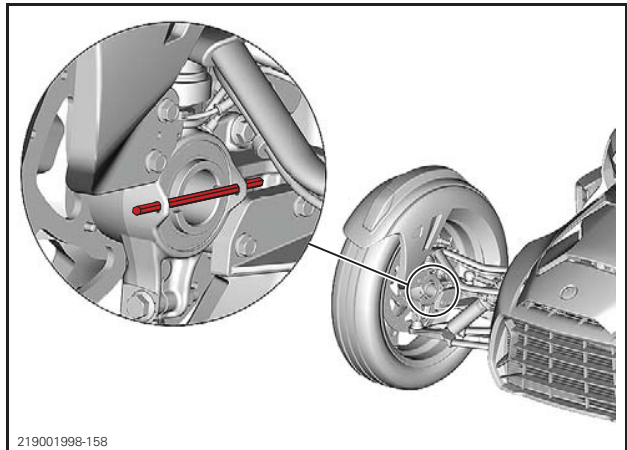

4. Remove the RED locking clip.

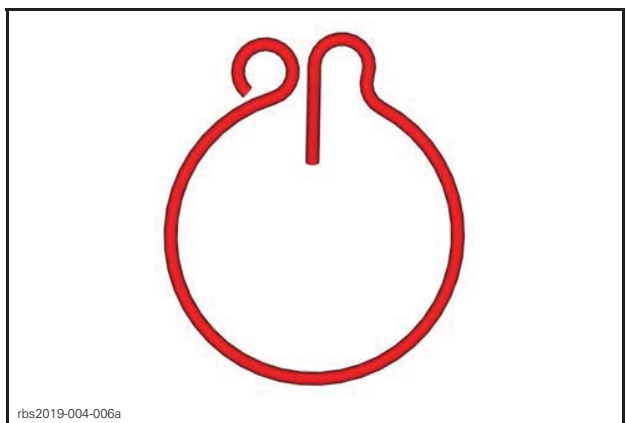

5. Remove and discard the center lock wheel nut.

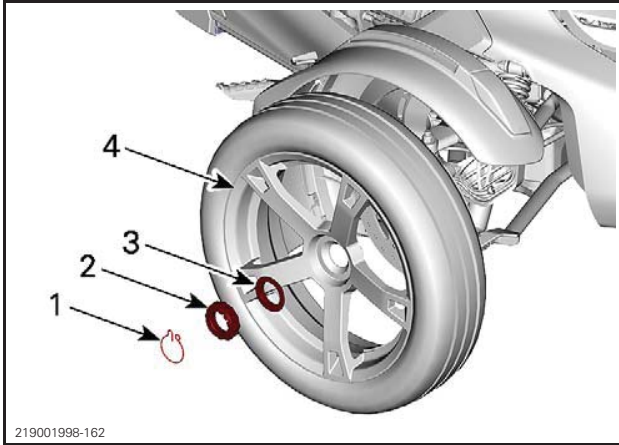

219001998-162

1. RED locking clip
2. Center lock wheel nut
3. Conical washer
4. Wheel

In the case of damaged parts, the standard warranty guidelines apply.

## Installing Front Wheel Nut

**NOTICE** The installation instruction and tightening torque values must be strictly adhered to. Failure to do so can lead to rim damage.

The installation is the reverse of the removal procedure. However, pay attention to the following. Tighten the center lock wheel nut to specification.

**NOTICE** Never use impact tools to tighten wheel nuts.

TIGHTENING TORQUE	
Center lock wheel nut	300 N•m ± 15 N•m (221 lbf•ft ± 11 lbf•ft)

**⚠ WARNING**  
Failure to install the RED locking clip may cause the loss of a wheel if the center lock wheel nut becomes loose.

RED locking clip installation is **Mandatory**  
The folded end must point inside the drive axle.

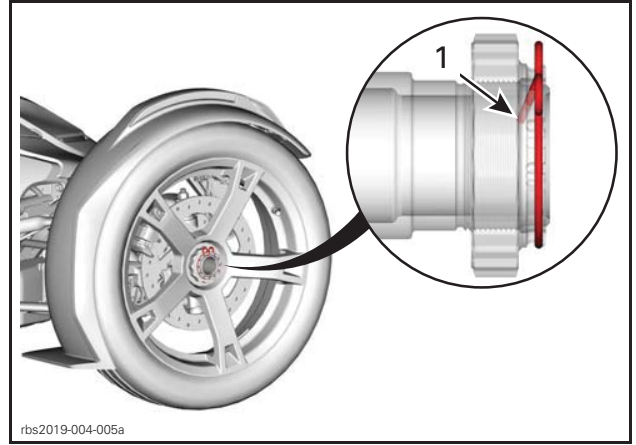

rbs2019-004-005a

1. Folded end pointing inside the drive axle

**NOTICE** Never untighten the nut to align the RED locking clip hole. Tighten the nut to the nominal value, then tighten further to align the hole.

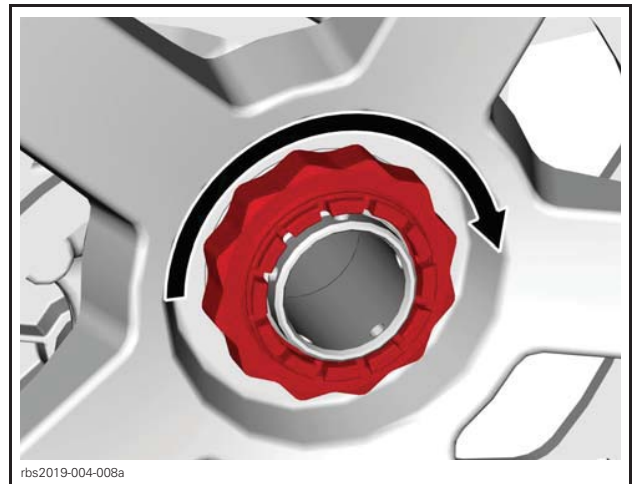

rbs2019-004-008a

Remove locking device from the wheel hub.

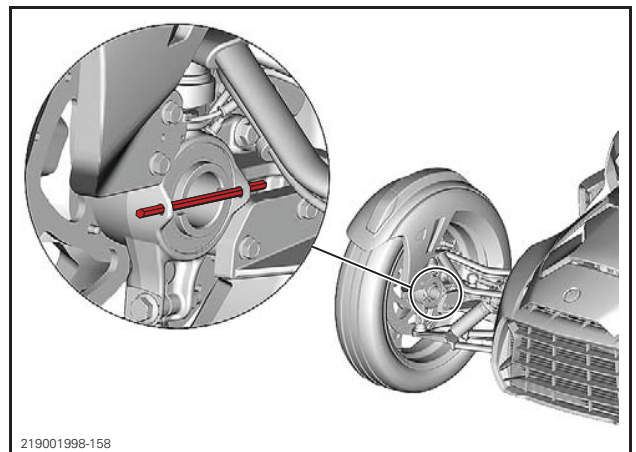

219001998-158

## Removing the Rear Wheel Nut

1. Place the vehicle on a level surface.

2. Move the park position lever in the locked position.
3. Remove the RED locking clip.

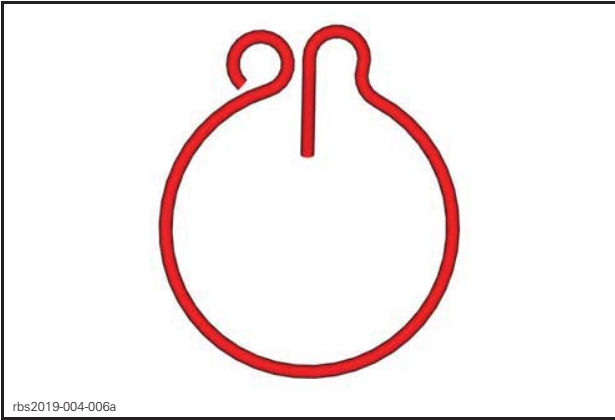

4. Loosen the center lock wheel nut.

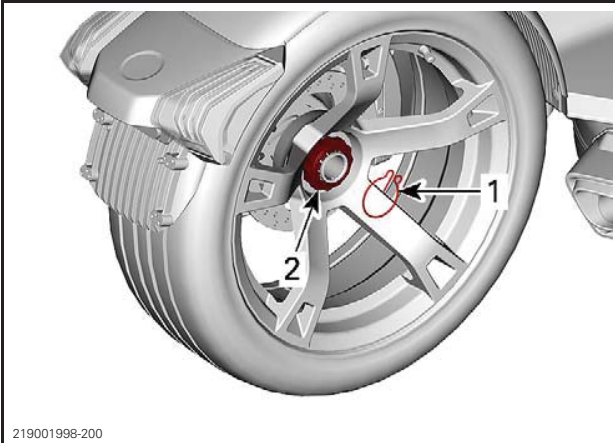

1. RED locking clip
2. Center lock wheel nut

5. Lift and support the rear of the vehicle.

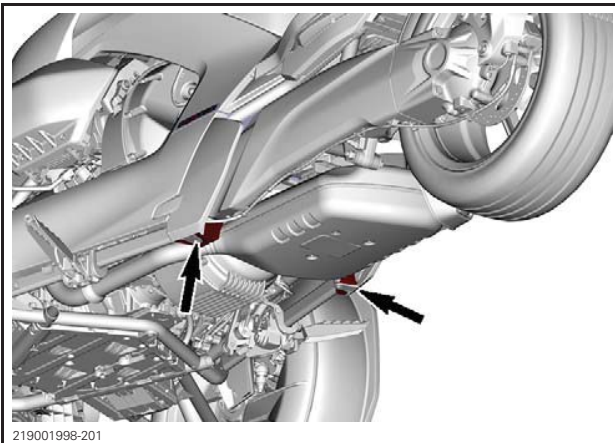

USE THESE LOCATIONS TO LIFT OR SUPPORT THE REAR OF THE VEHICLE

6. Remove and discard the center lock wheel nut.

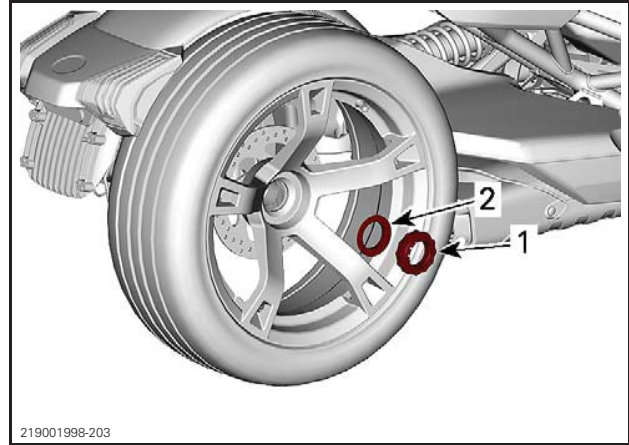

1. Center lock wheel nut
2. Conical washer

In the case of damaged parts, the standard warranty guidelines apply.

## Installing the Rear Wheel Nut

**NOTICE** The installation instruction and tightening torque values must be strictly adhered to. Failure to do so can lead to rim damage.

The installation is the reverse of the removal procedure. However, pay attention to the following. Tighten the center lock wheel nut to specification.

**NOTICE** Never use impact tools to tighten wheel nuts.

TIGHTENING TORQUE	
Center lock wheel nut	300 N•m ± 15 N•m (221 lbf•ft ± 11 lbf•ft)

**⚠ WARNING**  
Failure to install the RED locking clip may cause the loss of a wheel if the center lock wheel nut becomes loose.

RED locking clip installation is **Mandatory**

The folded end must point inside the drive axle.

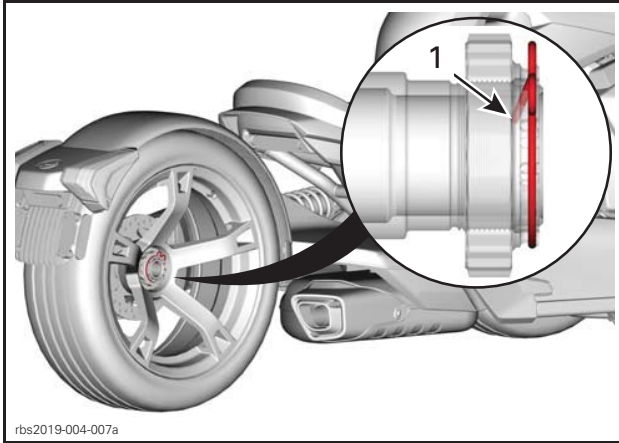

rbs2019-004-007a

1. Folded end pointing inside the drive axle

**NOTICE** Never untighten the nut to align the RED locking clip hole. Tighten the nut to the nominal value, then tighten further to align the hole.

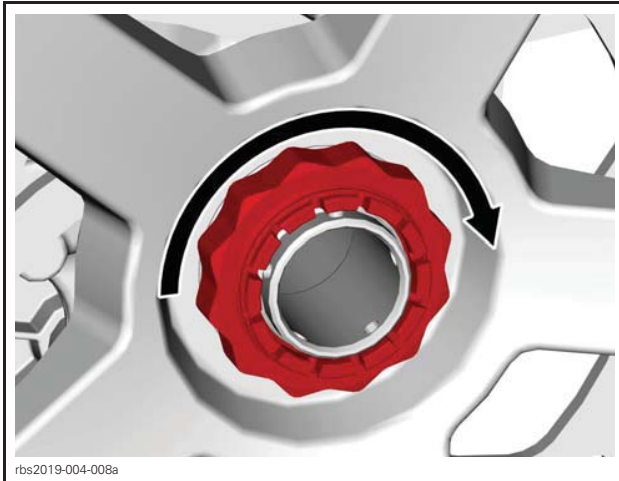

rbs2019-004-008a

## ► MANDATORY CERTIFICATION FORM ◀

This form MUST be signed by the technician who performed the procedure and by the Master technician or Service Manager as confirmation that the service was performed as per BRP's required procedure.

It MUST be signed by the customer.

A copy of the form must be given to the customer.

Dealership must keep his copy in the vehicle's file as proof.

Mandatory Certification of Front Wheels Installation		
Brand CAN-AM	Model Ryker	Vehicle Identification Number
I certify that the front wheels of this vehicle were installed as per BRP's required procedures.		
Technician's signature	Technician's PRINT NAME	Date
Master Technician's signature or Service Manager	Master Technician's signature or Service Manager PRINT NAME	Date
BRP or any government authority may ask for this document at anytime. Dealership must KEEP this in the vehicle's file.		
Customer's signature	Customer's PRINT NAME	Date
I confirm that I have received a copy of this CARD from the dealer.		

rbg2019-011-101

A TEMPLATE OF THE FORM IS PROVIDED WITH THIS BULLETIN.

## WARRANTY

Submit a warranty claim using the following information.

For claiming procedure, refer to the *DEALER/DISTRIBUTOR WARRANTY GUIDE*.

Product Line	Ryker
Unit Model Year	2019
Campaign/Bulletin/Description	14 / 2020-1 / Ryker Wheel Nut
<b>*Action</b>	
<b>Inspect</b>	<b>Repair</b>
<input type="checkbox"/>	<input checked="" type="checkbox"/>
Total Labor time paid	0.3 hour

Product Line	Ryker
Unit Model Year	2020
Campaign/Bulletin/Description	1 / 2020-1 / Ryker Wheel Nut
<b>*Action</b>	
<b>Inspect</b>	<b>Repair</b>
<input type="checkbox"/>	<input checked="" type="checkbox"/>
Total Labor time paid	0.3 hour