



# SAFETY RECALL BULLETIN

NHTSA RECALL 19V534

AUTOCAR, LLC SAFETY RECALL ACX-1905

July, 2019

### Attention:

Service Managers/Parts Managers.

### Subject:

Autocar has determined that a safety issue exists with the service brake release timing on certain 2019-2020 model year Xpeditor's

### Safety Recall Information:

This document contains information regarding the replacement and repositioning of specific pneumatic components to correct the brake release timing.

### Vehicles Affected:

There are 23 vehicles affected, manufactured after December 17, 2018. To determine if a vehicle is affected by this recall, log in to the Autocar Warranty Management System at [www.autocartruck.com](http://www.autocartruck.com). From the main menu, select "View Recalls/Service Programs" and look for the Autocar recall number above. An excel file will be accessible with the VIN list of affected vehicles. Alternatively, to determine if a single vehicle is affected, select "VIN Profile" from the main menu. In the "Chassis Number" field, enter the last six of the VIN. Once the VIN profile is displayed, scroll down to the "Recall/Service Program Information" section to determine if the recall is open.

### Service Responsibility:

Service sites must perform this recall on affected vehicles at no charge to the owner regardless of vehicle mileage, age or ownership. If a vehicle affected by this recall is taken into or is currently in your vehicle inventory, or at your center for service, you must perform this recall before the vehicle is sold or released to the owner.

### Claims for Reimbursement:

Submit a claim for reimbursement in accordance with Autocar's Warranty Administration Manual.

### Claim Coding Information:

Labor Operation Code Number	Time Allowance SRT	Description
56328-2-03	2.0 HR	Brake Timing Recall

### Parts Required:

- (1) S7442003K001 Service Kit
  - (1) 3082831 Brake Line 27"
  - (1) 3082832 Brake Line 30"
  - (2) 8061318 Pipe Tee Fitting
  - (1) 3082846 3/8" X 45 Degree Pipe Ell
  - (2) FE410137AW16 3/8" X 1.5" Bolt
  - (4) FE410125AW12 1/4" X 1" Bolt
  - (4) FE286225BW01 1/4" Lock Nut
  - (1) FE410137AW10 3/8" X 3/4" Bolt
  - (2) FE286237BW01 3/8" Lock Nut
  - (2) GZ220010-012 Stand Off Bracket
  - (1) GZ200041-086 90 Degree Tube Adapter

# SAFETY RECALL BULLETIN

NHTSA RECALL 19V534

AUTOCAR, LLC SAFETY RECALL ACX-1905

July, 2019

## SAFETY NOTICES:



### WARNING

Allow the vehicle's engine and cooling system to cool to ambient temperature before performing the repair procedure. A hot engine or cooling assembly may cause burns or other personal injury.



### WARNING

To prevent eye injury, always wear eye protection when performing vehicle maintenance, service or inspection.



### WARNING

Before working on a vehicle, set the parking brake, place the transmission in neutral and block the wheels. Failure to do so can result in unexpected vehicle movement and can cause serious personal injury or death.

## Working on CNG/LNG Trucks

### SAFETY INSTRUCTIONS

If you store or dispense Compressed Natural Gas (CNG) or Liquefied Natural Gas (LNG), or if you work on CNG or LNG trucks, your location must be fully compliant with applicable codes, regulations and standards, including National Fire Protection Associate (NFPA) codes, Society of Automotive Engineers (SAE) standards, American National Standards Institute (ANSI) Natural Gas Vehicle (NGV) standards, the United States Code of Federal Regulations (CFR) and your state and local fire and other applicable codes (including, for example, the California Code of Regulations and the Texas Administrative Code).

Contact your local fire department for guidance and additional compliance information.

Technicians working on Autocar trucks with CNG or LNG engines must be trained in the proper repair of CNG and LNG trucks and engines and the safe storage and dispensing of CNG and LNG.

# SAFETY RECALL BULLETIN

NHTSA RECALL 19V534

AUTOCAR, LLC SAFETY RECALL ACX-1905

July, 2019

## Working on CNG Fuel Systems



### WARNING

CNG fuel systems include a high pressure (3600 psi) system for fuel storage and a low pressure system (125 psi) for consumption by the engine. Understanding the characteristics of CNG and how the fuel system works will prevent injury and damage to persons and property.

Attempting to operate or maintain any CNG fuel system without proper training is dangerous. Complete training and consult instructional bulletins from the CNG system suppliers, such as Agility Fuel Systems' Field Service Bulletin, Safely Working on CNG Fuel Systems.

## Welding and Hot Work Near CNG and LNG Trucks



### WARNING

Welding, grinding and other "hot work" can be safely performed on or near a CNG or LNG vehicle, but certain precautions must be followed. Understand and perform the necessary precautions provided by the CNG system suppliers, such as Agility Fuel Systems' Field Service Bulletin, Welding and Hot Work Precautions Near CNG and LNG Vehicles.

## CNG Cylinders



### WARNING

CNG fuel containers must meet Federal Motor Vehicle Safety Standard (FMVSS) 304 (Compressed Natural Gas Fuel Container Integrity) and/or ANSI/CSA NGV2 (Basic Requirements for Compressed Natural Gas Vehicle Fuel Containers). Both standards specify a detailed visual examination every three years.

Ensure that every truck owner completes the required inspections, in accordance with the applicable standards and other resources, such as the Clean Vehicle Education Foundation and NGV America's Compressed Natural Gas (CNG) Container Visual Inspection Advisory.

FMVSS 304 also requires that cylinders not be used after the end of life (EOL) date provided on the tank label. The EOL date is also displayed in the engine compartment and at the fueling connection of each truck. If there is any question as to proper decommissioning of a cylinder, contact the manufacturer, whose name and address is also required to be on the label.

# SAFETY RECALL BULLETIN

NHTSA RECALL 19V534

AUTOCAR, LLC SAFETY RECALL ACX-1905

July, 2019

## CNG Fuel Container Pressure Relief Devices (PRDs)



### WARNING

PRDs must be properly maintained and positioned for safe operation of a CNG fuel system. Missing vent caps can allow moisture into PRDs and vent lines, which can freeze and damage these safety components. Debris which clogs the PRDs and/or vent lines can prevent proper function.

PRDs must be positioned to vent upward, not outward, from a vehicle.

Ensure that every truck owner completes periodic inspections of the PRDs and vent lines and systems, in accordance with guidance provided by the system component suppliers.

## Alert First Responders to CNG and LNG



### DANGER

In the event of a fire or other emergency, alert first responders to the presence and location of CNG fuel systems, tanks and dispensers. Ensure that emergency personnel are aware of proper precautions, such as those provided in Agility's *First Responder Guide: CNG and LNG Vehicle Fuel Systems*.



### CAUTION

## LOCKOUT/TAGOUT PROCEDURES

Before entering the vehicle or vehicle body, read and follow OSHA regulations concerning entry and working in "CONFINED SPACE" OSHA 1910.146 and "LOCKOUT/TAGOUT" OSHA 1910.147. Follow OSHA regulations while performing any work on the vehicle. The vehicle must be disabled by the following steps before performing any work on the vehicle:

1. Place the transmission in NEUTRAL.
2. Set the parking brake.
3. Shut the engine OFF.
4. Lock cab doors, keep the key in your pocket. Block the wheels before entering the body or performing any work on the vehicle.
5. Turn the battery disconnect switch OFF, if equipped.
6. Completely drain the air from the primary/A system and secondary/B system by opening the drain valves on the air tanks themselves or by using the drain manifold if supplied. When draining the air tanks, do not look into the area where air is draining. Dirt or sludge particles may be expelled in the air stream and can cause eye injury.
7. Place magnetic "DANGER" signs on both cab doors before entering the body or performing any work on the vehicle.
8. Take proper precautions before working under the vehicle. Use ramps approved for the weight of your vehicle, or use floor jacks and stands. Never work under a vehicle supported by jacks alone. Always use jack stands to support the vehicle.

# SAFETY RECALL BULLETIN

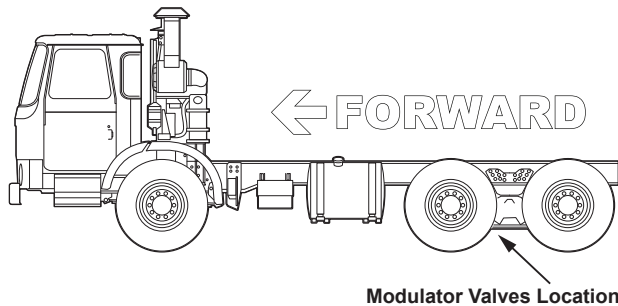
NHTSA RECALL 19V534

AUTOCAR, LLC SAFETY RECALL ACX-1905

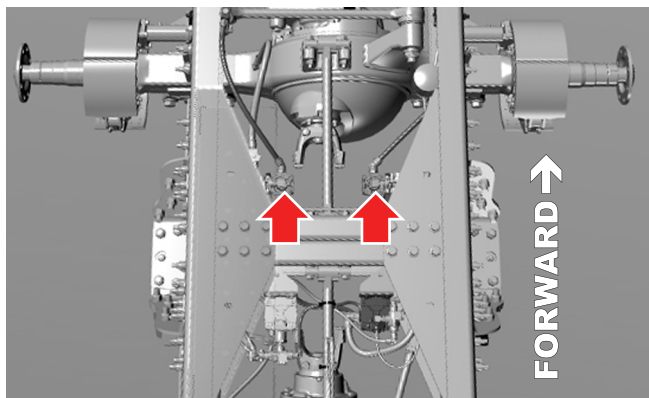
July, 2019

## BRAKE RELEASE TIMING CORRECTION PROCEDURE:

1. Complete the “LOCKOUT/TAGOUT PROCEDURES” on the preceding page and be sure to drain the air tanks completely and chock the wheels.
2. Locate the Anti-Lock Brake (ABS) Modulators and the Quick Release Valves (QRV) that are mounted on the forward side of the rear suspension cross member (see *Figure 1* and *Figure 2*).

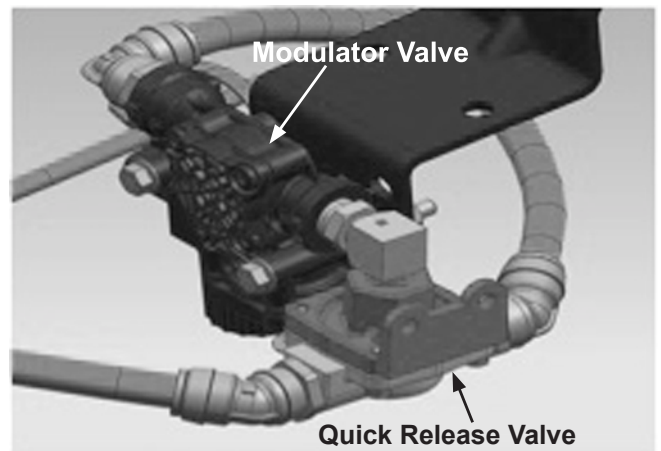


**Figure 1, Modulator and Quick Release Valves Location**



**Figure 2, Quick Release Valves (QRV)**

3. Disconnect the nylon tubing from the tube fittings and remove both of the QRV's and the adapter pipe nipples from the ABS Modulators. Discard the (2) adapter pipe nipples and set the QRV's aside for reinstallation (see *Figure 3*).



**Figure 3, Original Installation at ABS Modulator**

4. Install (2) 8061318 pipe Tee fittings, (1) into each ABS Modulator.(see *Figure 4*).



**Figure 4, Revised Installation at ABS Modulator**



# SAFETY RECALL BULLETIN

NHTSA RECALL 19V534

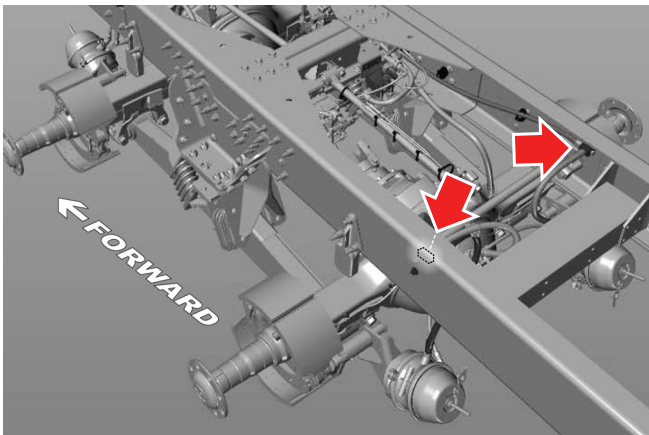
AUTOCAR, LLC SAFETY RECALL ACX-1905

July, 2019

5. Remove the (4) tube fittings from the QRV's (set aside in Step 3), apply thread sealant (obtain locally) and install the tube fittings into the pipe Tee fittings installed in Step 4. Set both QRV's aside for reinstallation.
6. Connect the nylon tubing (disconnected in Step 3) to the tube fittings installed in Step 5 (see Figure 4).

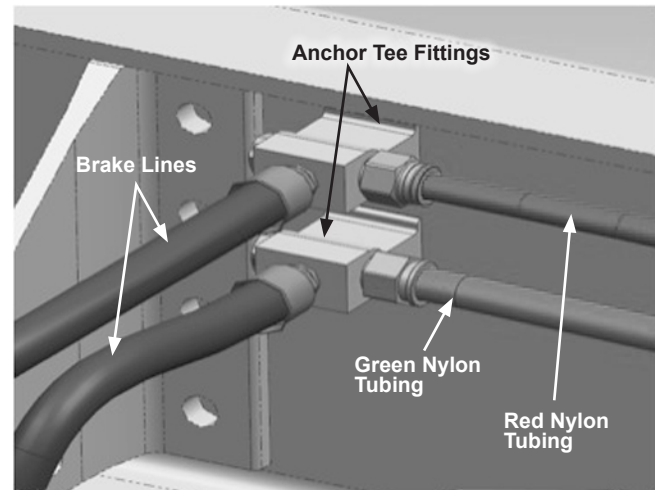
**NOTE:** *Trimming the nylon tubing may be required for best possible fit. Follow all proper routing and clipping guidelines to be sure the nylon tubing is secure and without possible rubbing.*

7. Locate the (2) service brake, anchor Tee fittings at both frame rails behind the rear drive axle (see Figures 5 and 6).



**Figure 5**

8. Beginning with the left side: Remove and discard the two rubber brake lines (service brake and parking brake) (see Figure 6).
9. Disconnect the service brake nylon tubing (green) from the anchor Tee fitting, remove the tube adapter fitting from the service brake anchor Tee and set the fitting aside for reinstallation (see Figure 6).
10. Disconnect the parking brake nylon tubing (red) from the anchor Tee fitting and remove both of the anchor Tee fittings from the left frame rail, remove the pipe plug from the service brake anchor Tee fitting and set aside for reinstallation, discard the service brake anchor Tee fitting and set the parking brake anchor Tee fitting aside for reinstallation (see Figure 6).



**Figure 6, Original Installation: Left Rear Frame**

# SAFETY RECALL BULLETIN

NHTSA RECALL 19V534

AUTOCAR, LLC SAFETY RECALL ACX-1905

July, 2019

11. Install (1) GZ220010-012 stand off bracket into the left frame rail using (1) FE410137AW16 bolt and (1) FE286237BW01 nut  
(see Figures 7 and 8).
12. Install one of the QRV's (set aside in Step 3) to the stand off bracket using (2) FE410125AW12 bolts and (2) FE286225BW01 nuts. Apply thread sealant (obtained locally) to the pipe plug (set aside in step 10) and install the pipe plug into the outboard port of the QRV.  
(see Figures 7 and 8).
13. Apply tread sealant (obtained locally) and install the tube adapter fitting (set aside in Step 9) into the QRV and connect the service brake nylon tubing (green)  
(see Figure 8).

**NOTE:** *Trimming the nylon tubing may be required for best possible fit. Follow all proper routing and clipping guidelines to be sure the nylon tubing is secure and without possible rubbing.*

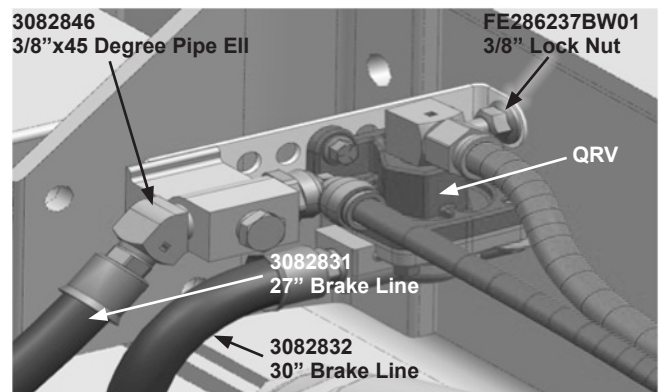
14. Install (1) 3082832 rubber brake line into the QRV and to the left rear service brake chamber (see Figure 7).
15. Locate the parking brake anchor Tee (set aside in Step 10). Remove the pipe plug from the end port of the anchor tee, apply thread sealant (obtained locally) and install the pipe plug into the center port of the anchor Tee fitting. Install (1) GZ200041-086 tube fitting into the open port (previously plugged) (see Figure 8).

16. Install the parking brake anchor Tee (set aside in Step 10) to the stand off bracket using (1) FE410137AW10 bolt  
(see Figure 9).

17. Connect the parking brake nylon tubing (red) to the tube fitting installed in Step 15.

**NOTE:** *Trimming the nylon tubing may be required for best possible fit. Follow all proper routing and clipping guidelines to be sure the nylon tubing is secure and without possible rubbing.*

18. Install (1) 3082846 fitting into the open port of the anchor Tee and install (1) 3082831 rubber brake line into the 3082846 fitting and to the left rear parking brake chamber (see Figure 7).



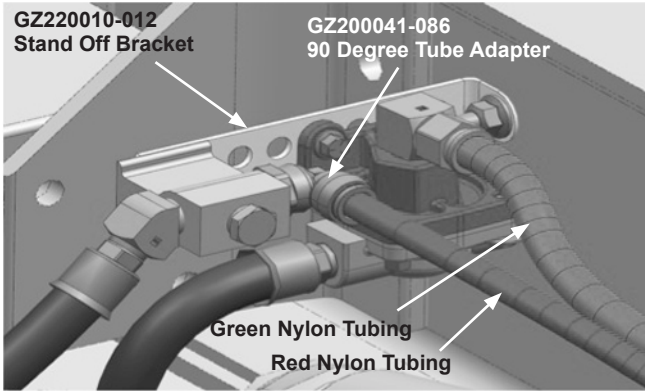
**Figure 7**

# SAFETY RECALL BULLETIN

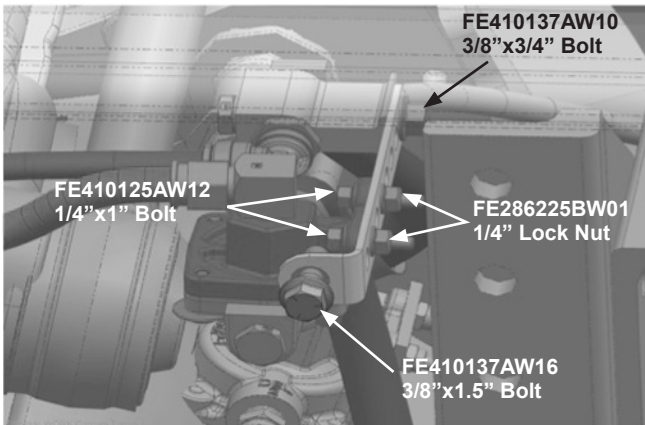
NHTSA RECALL 19V534

AUTOCAR, LLC SAFETY RECALL ACX-1905

July, 2019

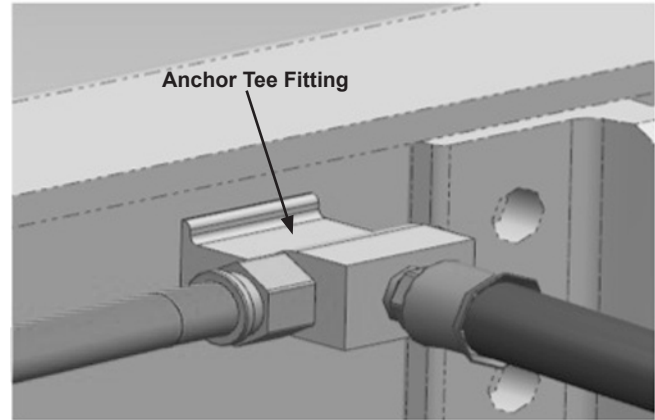


**Figure 8**



**Figure 9**

19. Continue to the right side: Locate the anchor Tee fitting (see *Figure 10*).



**Figure 10, Original Installation: Right Rear Frame**

20. Disconnect the rubber service brake line and the nylon service brake line (green) from the anchor Tee fitting.
21. Remove the pipe plug and the tube adapter fitting from the anchor Tee and set aside for reinstallation. Discard the anchor Tee.
22. Install (1) GZ220010-012 stand off bracket into the right frame rail using (1) FE410137AW16 bolt and (1) FE286237BW01 nut (see *Figure 11*).
23. Install the remaining QRV (set aside in Step 3) to the stand off bracket using (2) FE410125AW12 bolts and (2) FE286225BW01 nuts (see *Figures 11 and 12*).

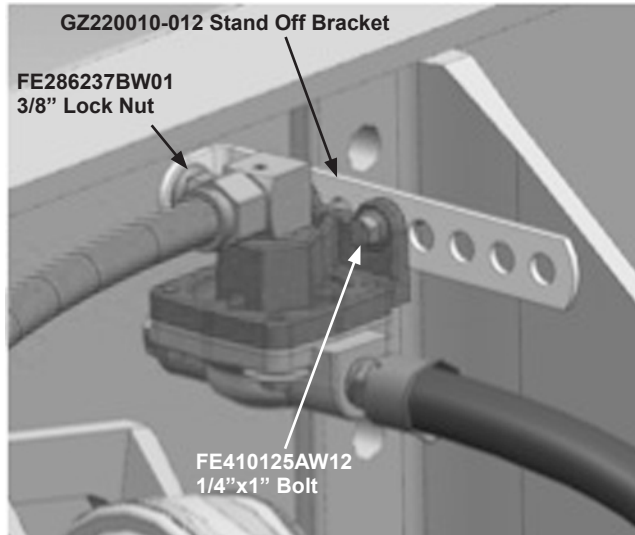


# SAFETY RECALL BULLETIN

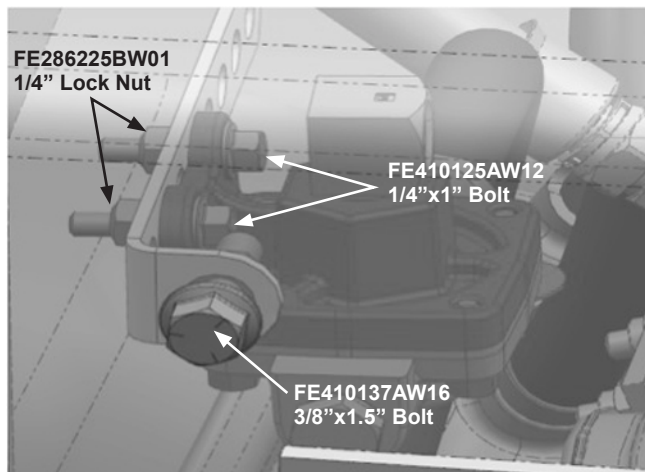
NHTSA RECALL 19V534

AUTOCAR, LLC SAFETY RECALL ACX-1905

July, 2019



**Figure 11**



**Figure 12**

24. Apply thread sealant (obtained locally) to the pipe plug and tube adapter fitting (set aside in Step 21). Install the pipe plug into the end port of the QRV and install the tube adapter fitting into the top port of the QRV.

25. Connect the nylon service brake line (green) to the tube adapter (installed in Step 24).

**NOTE:** *Trimming the nylon tubing may be required for best possible fit. Follow all proper routing and clipping guidelines to be sure the nylon tubing is secure and without possible rubbing.*

26. Apply thread sealant (obtained locally) to the rubber service brake line (disconnected in Step 20) and connect the rubber service brake line to the open port of the QRV.

27. Perform a functional test of the air brake system and check for air leaks.

28. Corrective procedures are complete.