



R19AI

SECOND FINAL NOTICE

DATE: March 24, 2022
TO: Blue Bird Owners
Subject: RECALL R19AI – Service Brake Switch Bracket Deformation on Driver Control Module

According to our records, we have not received confirmation that the above referenced recall, dated December 10, 2019, has been completed. A copy of Recall R19AI is attached. Your buses affected by Recall R19AI are identified by Blue Bird body number and VIN under Section 2 on the enclosed cover sheet.

If this is the first time you received notification of Recall R19AI, please read the enclosed notification carefully. Recall R19AI must be completed, as soon as possible. To correct this potential issue, Blue Bird will notify owners by mail and provide the affected dealers and owners with instructions on how to remove the existing brake switch mounting bracket and install the provided redesigned mounting bracket. Blue Bird will also provide a new brake switch, as part of the kit to ensure that the switch has the correct set point after the new brake switch mounting bracket is installed. Until the recall has been completed, drivers should confirm that the brake lights do not stay on during their pre-trip inspection.

Administering the Recall:

Blue Bird recommends that you contact your local or nearest Blue Bird Dealer to arrange for this recall to be performed.

Parts:

Parts to complete Recall R19AI can be obtained from Blue Bird Recall Administration via e-mail at campaignparts@blue-bird.com or by returning the yellow cover sheet to Blue Bird in the pink self-addressed, postage prepaid envelope to receive parts at no charge. You should retain a copy of the reply sheet for your records.

Labor Reimbursement:

Blue Bird will reimburse the labor cost of the repairs related to this recall at no cost to you the vehicle owner. The standard repair time (SRT) to accomplish these repairs in accordance with the recall installation procedure is 0.6 hours per bus.

Please contact your local Blue Bird Dealer with any questions regarding this recall campaign.

Thank you for your prompt attention to this matter.

BLUE BIRD BODY COMPANY
3920 Arkwright Road, Suite 200, Macon, GA 31210 – (478) 825-2021



R19AI

IMPORTANT SAFETY RECALL NOTICE

(Interim Notice)

NHTSA Recall Number: 19V-795 School Bus
NHTSA Recall Number: 19V-796 Non-School Bus

DATE: December 10, 2019

SUBJECT: RECALL R19AI – Service Brake Switch Bracket Deformation on Driver Control Module

Dear Blue Bird Owner:

This important safety recall notice applies to your bus(es) identified by both Blue Bird Body Number and Vehicle Identification Number (VIN) on the enclosed yellow cover sheet. If you no longer own the subject bus(es), please complete the appropriate section of the yellow coversheet and return to Blue Bird in the enclosed pink postage prepaid envelope.

This notice is sent to you in accordance with the requirements of the National Traffic and Motor Vehicle Safety Act.

Blue Bird Body Company is voluntarily recalling certain model year 2013 to 2020 Blue Bird Vision School Buses equipped with Ford engines manufactured from January 10, 2012 through August 7, 2019 and certain model year 2013 to 2020 Blue Bird Vision Non-school Buses manufactured from November 20, 2012 through March 28, 2019. On the subject buses, the potential exists that the brake switch mounting bracket could deform, as a result of a rapid return of the brake pedal to the non-braking position. This is most commonly a result of the driver's foot slipping off of the brake pedal while the pedal is fully depressed. A deformed brake switch mounting bracket could result in continuously illuminated brake lights and a brake warning light in the vehicle instrument cluster. There is no direct safety consequence because the brake system continues to function normally. However, local operating procedures may require the bus to stop immediately due to the illuminated brake warning light in the vehicle's instrument cluster. The transfer of passengers to another bus in potentially hazardous conditions could increase the risk of injury.

To correct this potential issue, Blue Bird will provide the owners with instructions on how to remove the existing brake switch mounting bracket and install the provided redesigned mounting bracket. Blue Bird will also provide a new brake switch as part of the kit to ensure that the switch has the correct set point after the new brake switch mounting bracket is installed. **Parts for this recall are anticipated to be available in March, 2020. Campaigns Administration will notify you again, when the parts are available.**

Blue Bird will reimburse the labor cost of the repairs related to this recall at no cost to the vehicle owner. The standard repair time (SRT) to accomplish these repairs in accordance with the recall installation procedure is 0.6 hours per bus.

Parts to complete Recall R19AI can be obtained from Blue Bird Recall Administration via e-mail at campaignparts@blue-bird.com or by returning the yellow cover sheet to Blue Bird in the pink self-addressed, postage prepaid envelope to receive parts at no charge. You should retain a copy of the reply sheet for your records.

Federal law requires that any vehicle lessor receiving this recall notice must forward a copy of this notice to the lessee within ten days.

BLUE BIRD BODY COMPANY
3920 Arkwright Road, Suite 200, Macon, GA 31210 – (478) 825-2021



BLUE BIRD

Blue Bird Body Company

Page 2

R19AI

If the modifications directed by this notification were performed on your bus prior to the receipt of this recall notification, attach a copy of the work order/invoice. Mail the documents in the pink self-addressed postage prepaid envelope included with the pink reply sheet to Blue Bird for warranty consideration. Reimbursements will be made in accordance with the requirements of the National Highway Transportation Safety Act, Title 49 Code of Federal Regulations, Parts 573 and 577.

Please contact your local Blue Bird Dealer with any questions regarding this recall campaign.

If Blue Bird Body Company should fail to or is unable to remedy this condition without charge to you, you may contact:

**ADMINISTRATOR
NATIONAL HIGHWAY TRAFFIC SAFETY ADMINISTRATION
1200 NEW JERSEY AVENUE, SE
WASHINGTON, D.C. 20590**

Or, you may call The National Highway Traffic Safety Administration toll free at:
1-888-327-4236 TTY 1-800-424-9153 or go to: <http://www.safercar.gov>



RECALL

R19AI – Ford Service Brake Switch Bracket Deformation

Models Affected: Certain model year 2013 thru 2020 Vision Buses with Ford Engines and Air Brakes.

Issue: The brake switch mounting bracket could deform, as a result of a rapid return of the brake pedal to the non-braking position.

Corrective Action: Remove and replace the existing brake switch mounting bracket, brake switch and striker.

Note: Only one of each kit will be used per unit.

Item Number	Part Number	Description	Quantity
1	10069220	Kit, Service, Ford Brake Switch, Air	1
Kit above includes the individual parts listed below:			
	Bendix	Bracket, Mounting, Brake Switch	1
	Bendix	Bumper, Rubber	1
	Bendix	Striker, Air	1
	10026469	Switch, Brake, Ford, 2 Pole	1

WARNING: Always follow all Federal, State, Local and Shop safety standards and use proper safety equipment, and thoroughly read and understand all instructions before performing these procedures.

Park bus on level surface, apply parking brake, turn off ignition key, and chock wheels.

Removal Instructions:

1. Locate service brake switch in front of driver's area, above brake pedal arm.
2. Disconnect the electrical connector from the service brake switch.
3. Rotate the service brake switch clockwise to the 7 o'clock position, and remove. (Figure 1)
The switch will not be reused, it should be marked as bad and discarded.
4. Remove the two fasteners mounting the switch mounting bracket to the steering column housing. Retain the mounting fasteners. *The switch bracket will not be reused, it should be discarded.* (Figure 2 and 3)
5. Remove and retain the E-Clip, nut and washer from brake pedal pivot shaft (Figure 3)
6. Remove the rue ring (or cotter key) and clevis pin from yoke/brake pedal (Figure 2)
7. If necessary, back off the pedal stop (threaded bolt) from steering column bracket to allow free motion of the brake pedal. (Figure 2)
8. Rotate brake pedal fore and aft, as necessary, while sliding to the right until removed from pivot shaft. (Figure 3)
9. Remove striker bracket from brake pedal assembly. (Figure 3) Retain the 1/2" striker nut, bolt and washers, as they will be reused.
The striker bracket will not be reused, it should be discarded.

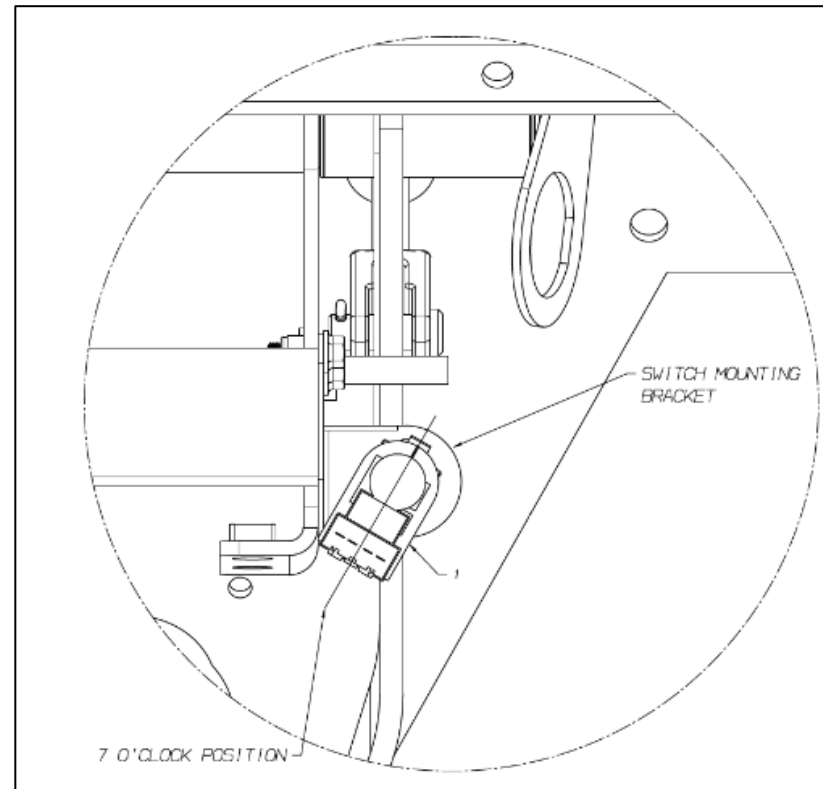

Figure 1

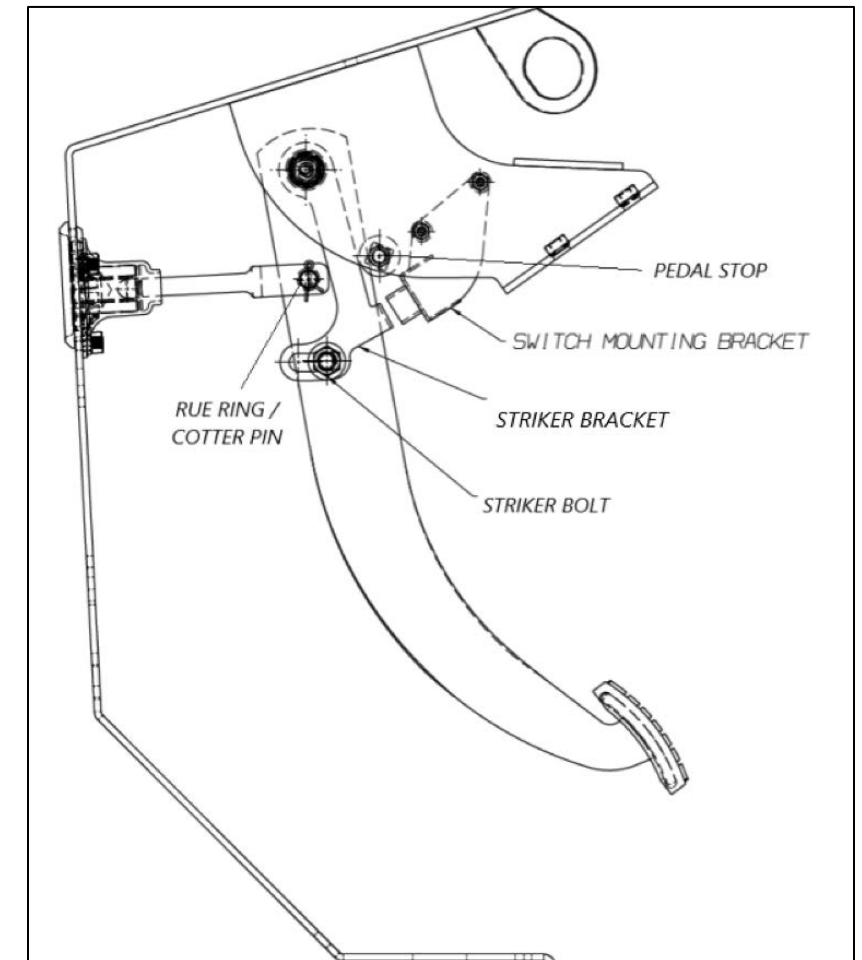

Figure 2

CAUTION - The brake switch is self-adjusting; therefore, proper positioning of the brake pedal and striker is critical.

Installation Instructions:

1. Install new striker onto the brake pedal using the ½” striker nut, bolt and washers previously removed.
Note: Leave the striker nut loose, as final adjustments are required in step 9.
2. Reinstall the brake pedal onto the pivot shaft. While sliding it to the left on the shaft be sure to place yoke back into place.
3. Secure the yoke to the brake pedal, install the clevis pin and rue ring (or cotter pin) from the removal process.
4. Secure the brake pedal to the pivot shaft using the nut and washer from the removal process and torque to 225-260 in-lbs.
5. Reinstall the E-clip to the end of the pivot shaft.
6. If loosened, re-tighten the pedal stop bolt.
7. Install the new brake switch mounting bracket into place on the steering column base and secure using the fasteners from the removal process, torquing them to 35-50 inch-lbs.
8. With the brake pedal in its normal, unapplied position, move the striker so that it meets with the rubber stop on the switch bracket. Make an alignment mark across the striker and brake pedal.
9. Install the rubber bumper into the brake switch mounting bracket
10. Line the alignment marks on the pedal and striker and add a C-clamp to hold the striker firmly against the brake pedal to prevent movement. Tighten the striker nut and bolt to 50 ft-lbs.
11. Remove C-clamp. Depress and release brake pedal, verify pedal returns and stops against rubber bumper without brake application.
12. **CAUTION-Ensure brake pedal remains in the normal, unapplied position for the next step.** Install the brake switch at the 7 o’clock position and rotate counterclockwise until it locks into place at the 6 o’clock position.
13. Reconnect the electrical connector to the brake switch.
14. **REQUIRED:** Verify switch operation using diagnostic software to monitor the brake switch outputs. The following steps are using ROUSH RDT Diagnostics.
 - a. Connect OBD II communication device
 - b. Select “Vehicle ID” and connect
 - c. Select “Signals/Datalogger”
 - d. Select “Standard Datalogger”
 - e. Select/Highlight “BPP1” and “BPP2”
 - f. Then select either table or graph at the lower left hand of the screen
 - g. Monitor screen, both values should be “False” or “Low”
 - h. Depress Brake Pedal, both values should change to “True” or “High”

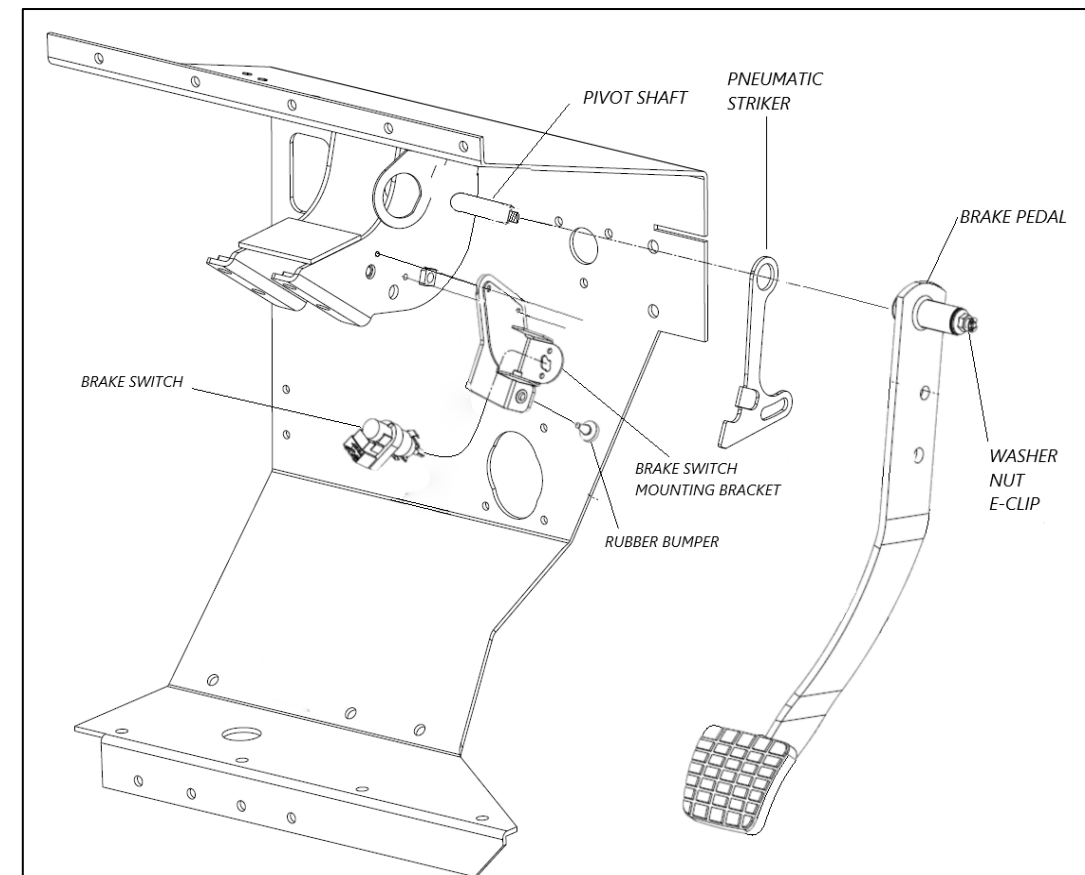

Figure 3