



February 2020

Dealer Service Instructions for:

# Safety Recall VE4 / NHTSA 19V-885 Occupant Restraint Control Module

---

## Remedy Available

### 2005-2006 (ZB) Dodge Viper

*NOTE: Some vehicles above may have been identified as not involved in this recall and therefore have been excluded from this recall.*

**IMPORTANT:** Some of the involved vehicles may be in dealer used vehicle inventory. Dealers should complete this recall service on these vehicles before retail delivery. Dealers should also perform this recall on vehicles in for service. Involved vehicles can be determined by using the VIP inquiry process.

## Subject

The Occupant Restraint Control (ORC) module on about 3,300 of the above vehicles may inadvertently deploy the airbags and/or seat belt pretensioners. The airbag warning light may or may not precede an inadvertent deployment of the airbags and/or seat belt pretensioners. Airbags or pretensioners that unexpectedly deploy may cause injury or can cause a vehicle crash without prior warning.

## Repair

The ORC module must be replaced on all involved vehicles.

**Alternate Transportation**

Dealers should attempt to minimize customer inconvenience by placing the owner in a loaner vehicle if the vehicle must be held overnight.

**Parts Information**

<u>Part Number</u>	<u>Description</u>
<b>CBSZR068AA</b>	<b>ORC Module</b>

**Parts Return**

No parts return required for this campaign.

**Special Tools**

**NOTE: For DRB III Enhanced Emulator and TechTOOLS requirements and troubleshooting, consult the wiTECH Knowledge Base from the wiTECH 2.0 menu.**

**The following special tools are required to perform this repair:**

- NPN                      wiTECH MicroPod II
- NPN                      Laptop Computer
- NPN                      wiTECH 1.0 Software
- NPN                      DRB III Enhanced Emulator Tool Software

**Service Procedure**

**WARNING: DISCONNECT AND ISOLATE THE NEGATIVE BATTERY CABLE AT THE NEGATIVE BATTERY POST BEFORE BEGINNING AIRBAG SYSTEM COMPONENT REMOVAL OR INSTALLATION PROCEDURES. THIS WILL DISABLE THE AIRBAG SYSTEM. FAILURE TO DISCONNECT THE BATTERY COULD RESULT IN ACCIDENTAL AIRBAG DEPLOYMENT AND POSSIBLE PERSONAL INJURY.**

**WARNING: ALLOW THE SYSTEM CAPACITOR TO DISCHARGE FOR TWO MINUTES BEFORE REMOVING ANY AIRBAG COMPONENTS.**

1. Roll down both windows.
2. Open the rear deck lid.
3. Remove the lower carpet from the trunk area to expose the battery compartment cover.
4. Remove and save five screws and the battery access cover located in the trunk (Figure 1).
5. Disconnect and isolate the negative cable from the battery (Figure 2).

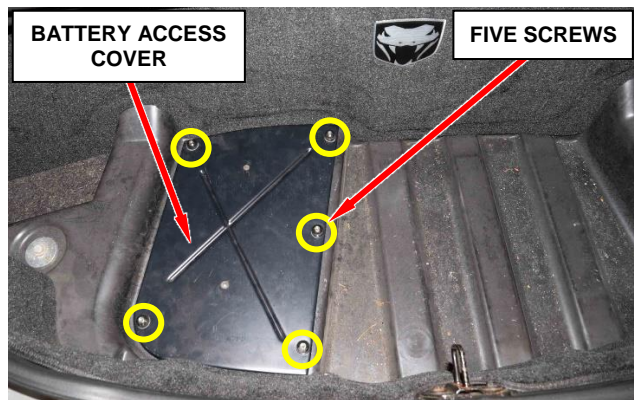

**Figure 1 – Battery Access Cover**

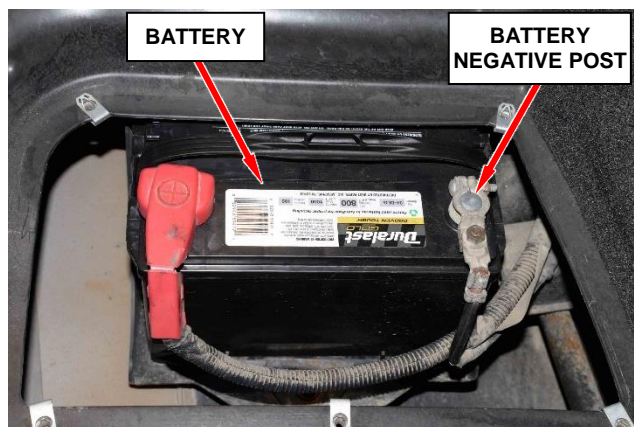
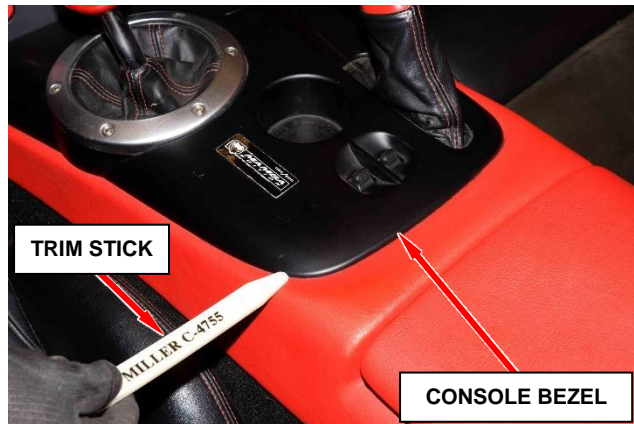

**Figure 2 – Battery Location**

**WARNING: wait two minutes for the airbag system reserve capacitor to discharge before beginning any airbag system or instrument panel component service.**

**Service Procedure [Continued]**

6. Use a trim stick to carefully release the center console bezel retaining clips (Figure 3).



**Figure 3 – Center Console Bezel**

7. Reach under the center console bezel to release the two window switch electrical connectors (Figure 4).

8. Slide the boot over the park brake lever handle while raising the rear edge of the center console bezel (Figure 4).



**Figure 4 – Center Console Bezel**

9. Reach under the center console bezel to disconnect the cigar lighter electrical connector (Figure 4).

10. Reach under the center console bezel to loosen the jam nut that retains the gear shift lever to the transmission shifter shaft (Figure 5).

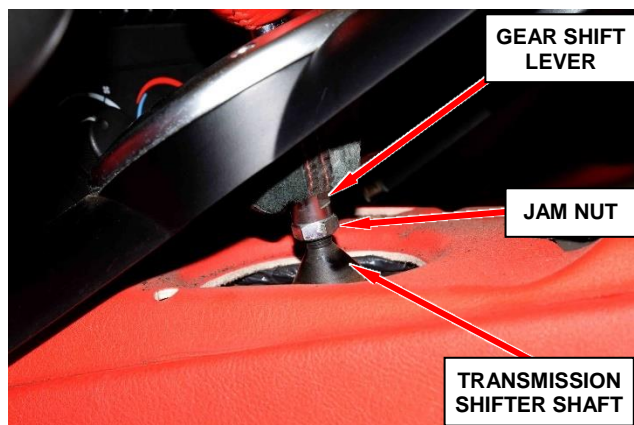

**Figure 5 – Gear Shift Lever Jam Nut**

11. Unscrew the gear shift lever from the transmission shifter shaft.

12. Remove the center console bezel and gear shift lever as an assembly.

**Service Procedure [Continued]**

13. Remove the seven screws securing the instrument panel center stack bezel (Figure 6).
14. Carefully pull the center stack bezel with HVAC control panel forward to access electrical connectors (Figure 6).
15. Disconnect the electrical connectors from the back of the HVAC control panel and engine start button.

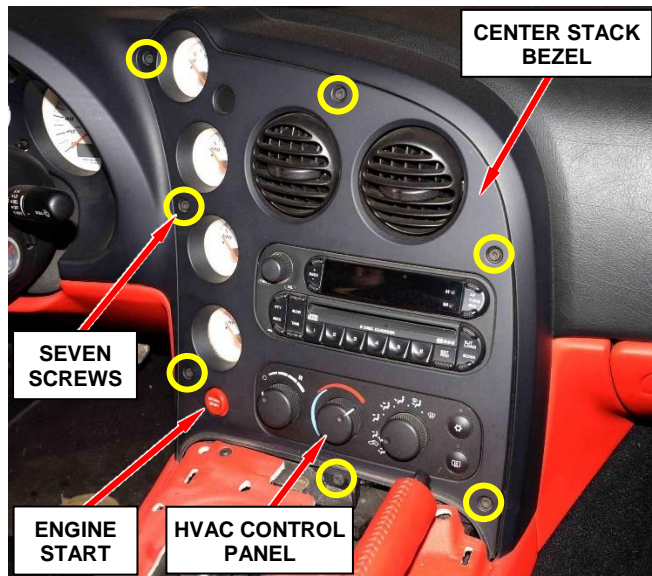

**Figure 6 – Center Stack Bezel**

16. Remove the center stack bezel and HVAC control panel as an assembly.
17. Using a trim stick, release the retaining clips and remove the door sill opening scuff plate (1) (Figure 7).
18. Remove the screw (2) from the cowl side trim panel (Figure 7).

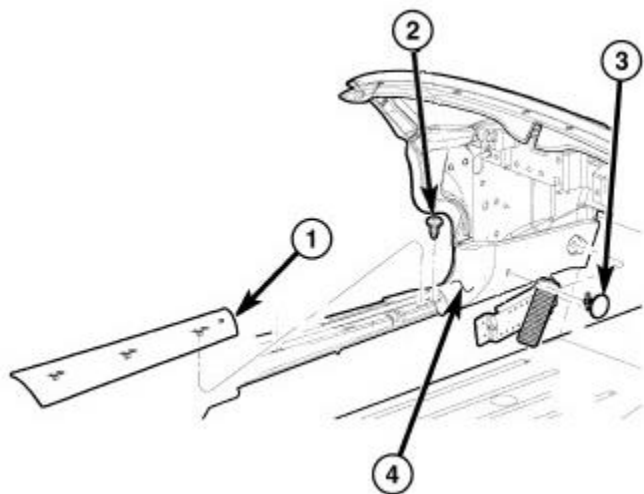

**Figure 7 – Door Sill and Cowl Trim Panels**

19. Remove the two push pin fasteners (3) from the cowl side trim panel (Figure 7).
20. Remove the cowl side trim panel (4) (Figure 7).

**Service Procedure [Continued]**

21. Remove two screws then release the retaining clips securing the left side steering column cover (Figure 8).

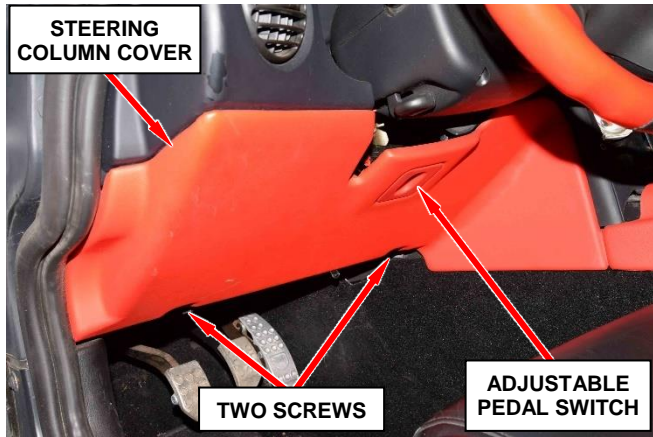

Figure 8 – Steering Column Cover

22. **If equipped**, disconnect the adjustable pedal switch electrical connector from the left side steering column cover (Figure 8).

23. Remove the left side steering column cover from the vehicle (Figure 8).

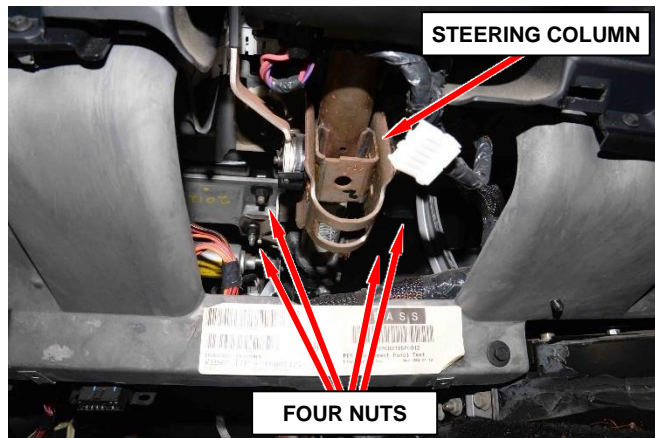

Figure 9 – Steering Column

24. Remove the four nuts securing the steering column to the cross car beam (Figure 9).

25. Carefully lower the steering column for access to the instrument cluster bezel (Figure 10)

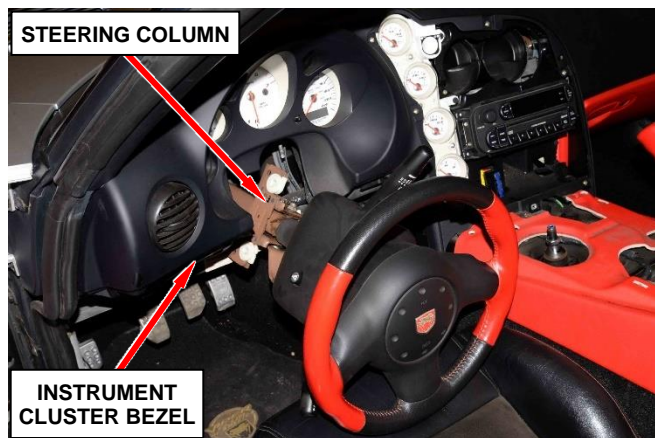

Figure 10 – Steering Column

**Service Procedure [Continued]**

26. Using a trim stick, remove the left side speaker grill from the instrument panel (Figure 11).



Figure 11 – Speaker Grill

27. Remove the three screws (two left side of steering column and one right side of steering column) securing the instrument cluster bezel (Figure 12).

28. Remove the two screws from the center console securing the instrument cluster bezel (Figure 12).

29. Release the instrument cluster bezel retaining clips then tilt the bezel rearward away from the instrument panel while disconnecting the air vent (Figure 12).

30. Release the wire harness retainer from the instrument cluster bezel then remove the bezel from the vehicle (Figure 12).

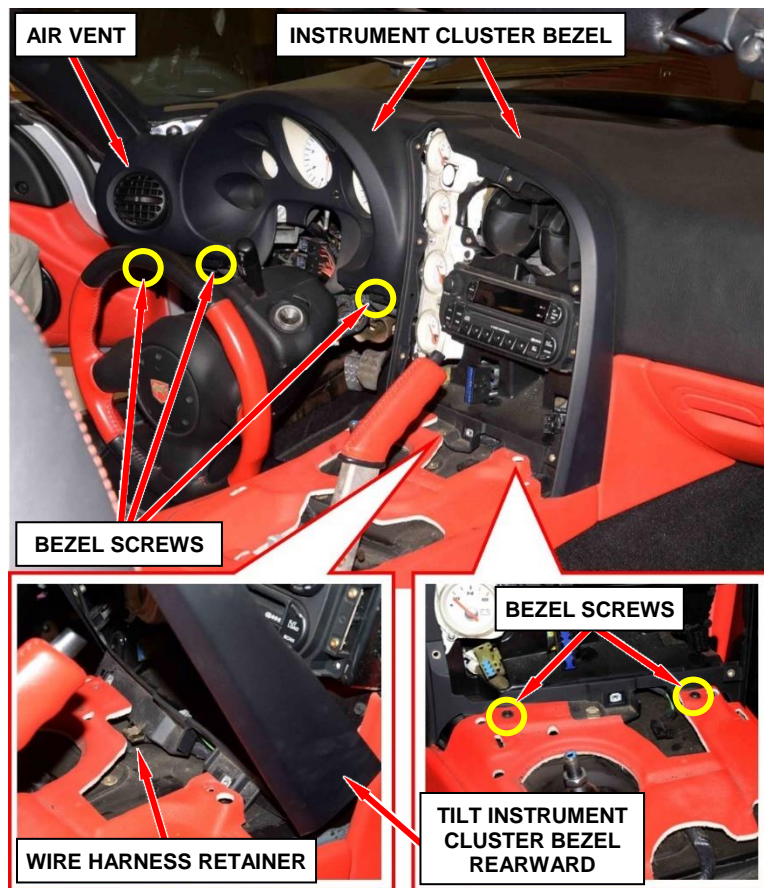

Figure 12 – Instrument Cluster Bezel

**Service Procedure [Continued]**

31. Remove four screws securing the radio to the instrument panel (Figure 13).

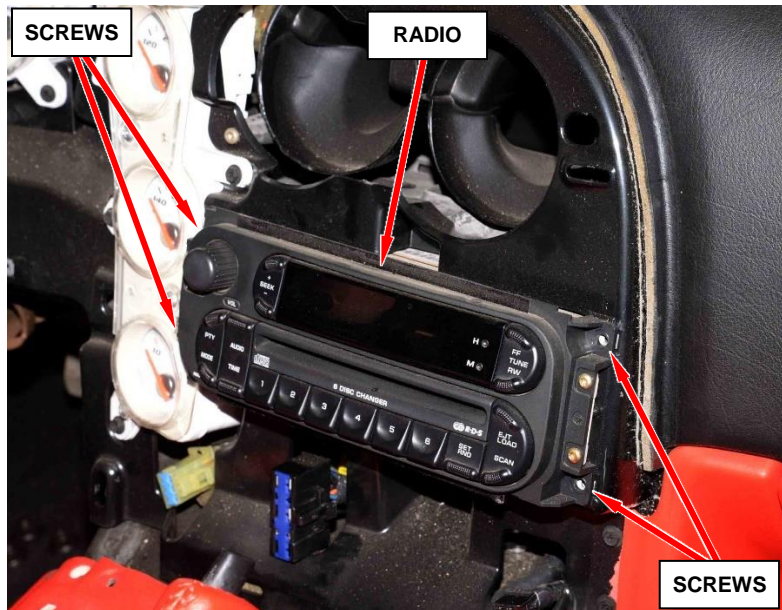

Figure 13 – Radio

32. Carefully pull the radio out of the instrument panel. Disconnect the antenna wire and the electrical connector from the back of the radio. Then remove the radio from the vehicle (Figure 14).

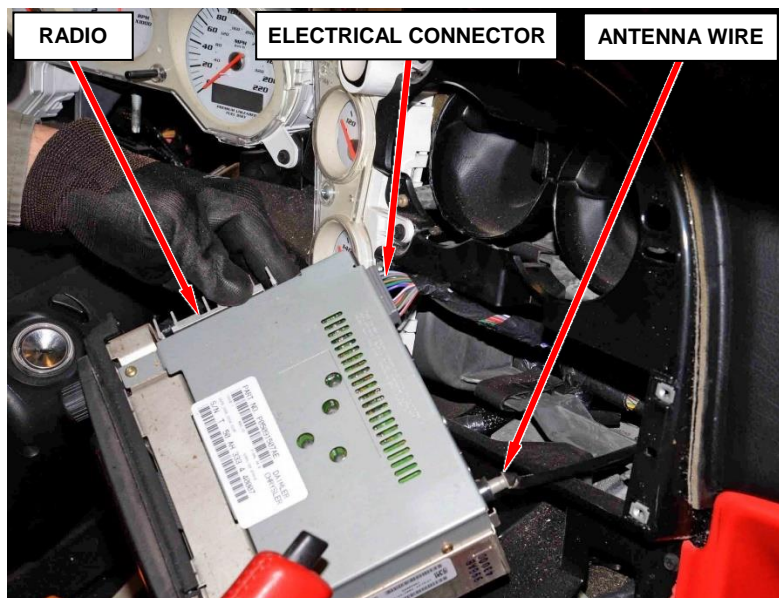
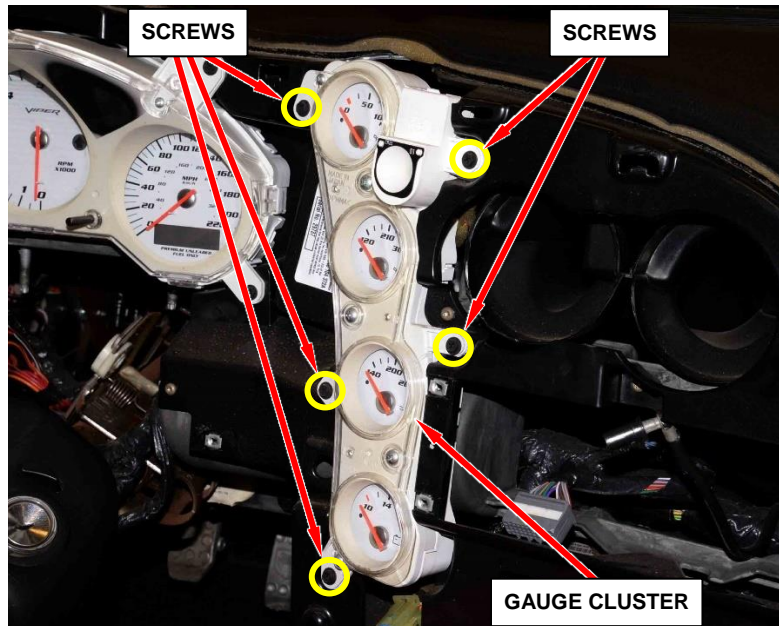

Figure 14 – Radio Electrical Connector and Antenna Wire



**Service Procedure [Continued]**

33. Remove five screws securing the gauge cluster to the instrument panel (Figure 15).



**Figure 15 – Gauge Cluster**

34. Carefully pull the gauge cluster away from the instrument panel and disconnect the two electrical connectors from the back of the gauge cluster. Then remove the gauge cluster from the vehicle (Figure 16).

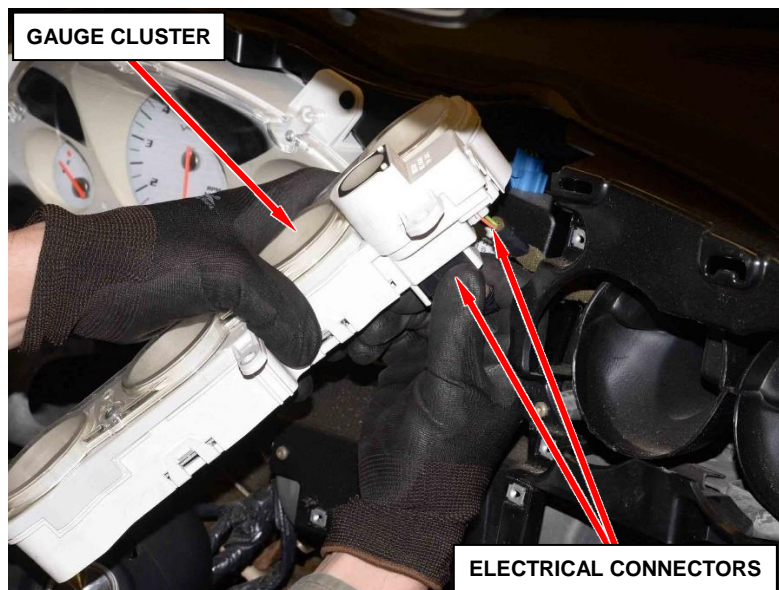

**Figure 16 – Gauge Cluster Electrical Connector**

**Service Procedure [Continued]**

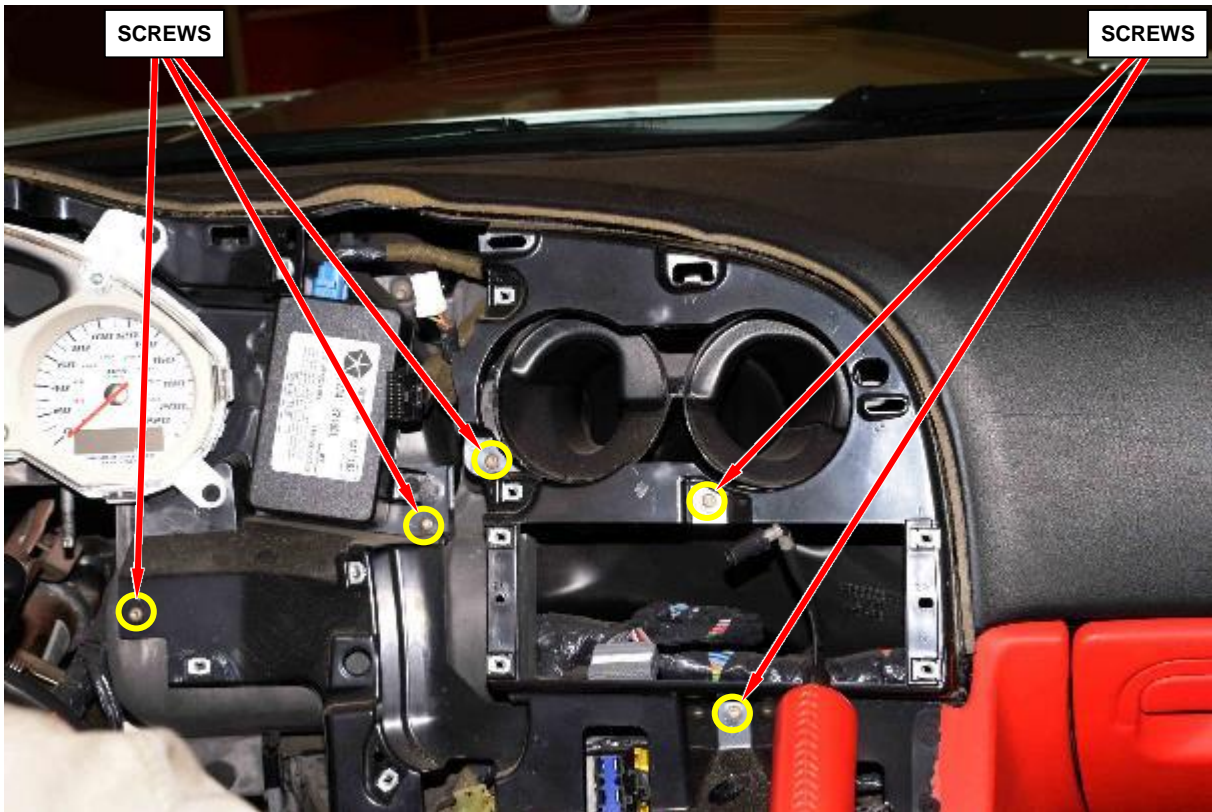

**Figure 17 – Five Screws Securing Instrument Panel Frame**

35. Remove five screws securing the instrument panel frame to the cross car beam and air duct (Figure 17).

36. Open the glove box then remove the two screws securing the left side glove box surround to the instrument panel (Figure 18).

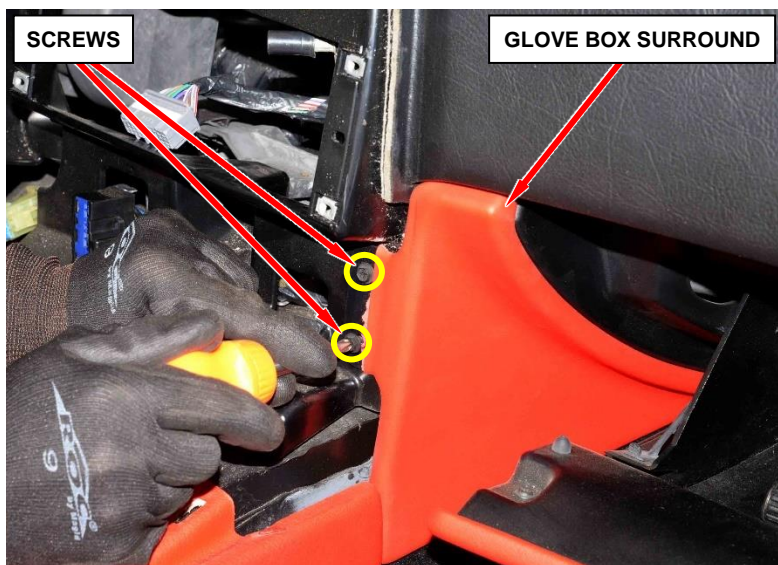

**Figure 18 – Glove Box Surround Screws**

**Service Procedure [Continued]**

37. Release the wire harness retainer from the floor stud (Figure 19).

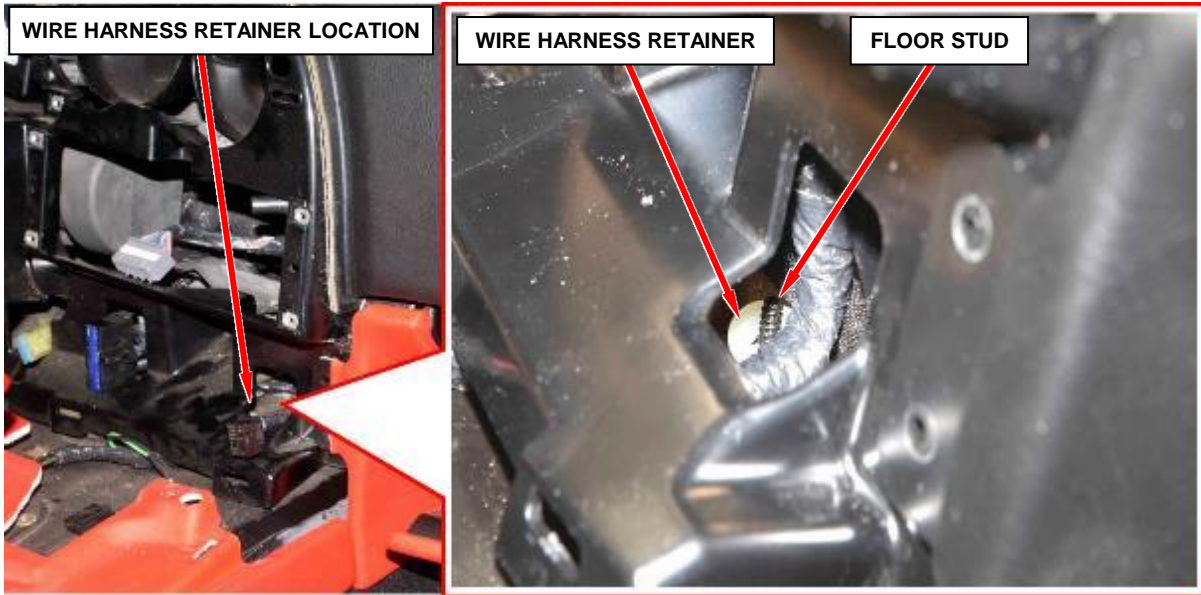

**Figure 19 – Wire Harness Retainer**

38. As necessary for access to the ORC module, carefully reposition any wire harnesses located near the ORC module (Figure 20).

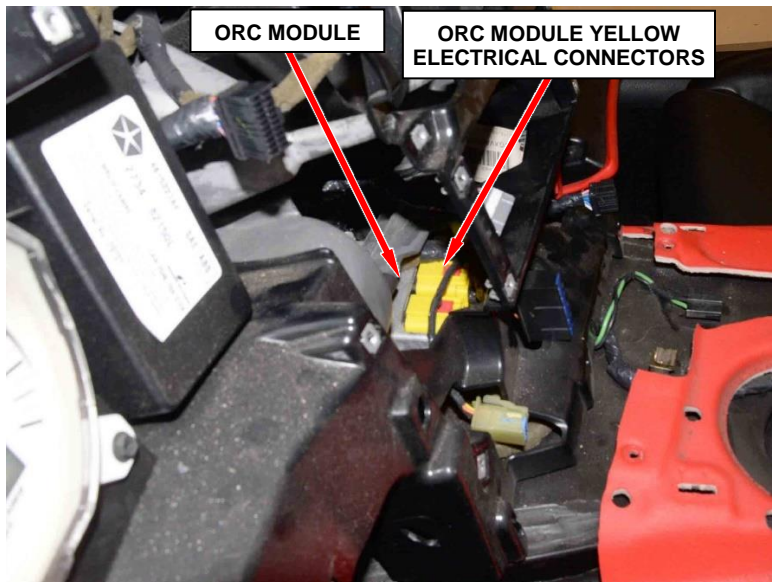

**Figure 20 – ORC Module**

**Service Procedure [Continued]**

39. Disconnect the yellow electrical connectors from the ORC module (Figures 20 and 21).
40. Remove and save the ORC module mounting bolts (Figure 22).
41. Slide the ORC module to the left to remove from the instrument panel.
42. Destroy, and discard the original ORC module.
43. Install the new ORC module.
44. Install the ORC module mounting bolts. Tighten the bolts to 11 N·m (95 in. lbs.) (Figure 22).
45. Connect the yellow electrical connectors to the ORC module (Figures 20 and 21).

**NOTE: The ORC module yellow electrical connectors are marked (A) for Driver side and (B) for Passenger side. The ORC module wire harness is also marked with (D) for Driver side and (P) for Passenger side (Figure 21).**



**Figure 21 – ORC Module Electrical Connectors**

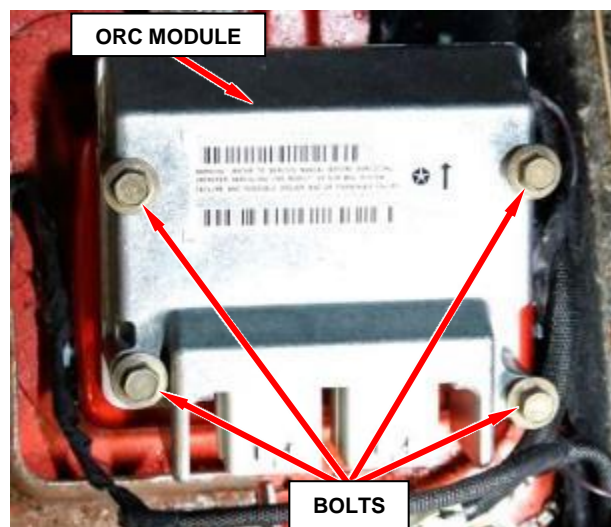

**Figure 22 – ORC Module**

**Service Procedure [Continued]**

46. Secure the wire harness retainer to the floor stud (Figure 19).
47. Install the two screws securing the left side glove box surround to the instrument panel then close the glove box door (Figure 18).
48. Install the five screws securing the instrument panel frame to the cross car beam and air duct (Figure 17).
49. Connect the two electrical connectors to the back of the gauge cluster then install the gauge cluster to the instrument panel (Figure 16).
50. Install the five screws securing the gauge cluster to the instrument panel (Figure 15).
51. Connect the antenna wire and electrical connector to the back of the radio then install the radio to the instrument panel (Figure 14).
52. Install the four screws securing the radio to the instrument panel (Figure 13).
53. Secure the wire harness retainer to the instrument cluster bezel and align the air duct while positioning the bezel to the instrument panel (Figure 12).
54. Engage the instrument cluster bezel retaining clips securing the bezel to the instrument panel (Figure 12).
55. Install the two screws securing the instrument cluster bezel to the center console (Figure 12).

**Service Procedure [Continued]**

56. Install the three screws (two left side of steering column and one right side of steering column) securing the instrument cluster bezel (Figure 12).
57. Install the left side speaker grill to the instrument panel (Figure 11).
58. Raise the steering column to the cross car beam then install the four nuts securing the steering column. Tighten the nuts to 17 N·m (150 in. lbs.) (12.5 ft. lbs.) (Figure 10).
59. **If equipped**, connect the adjustable pedal switch electrical connector to the left side steering column cover (Figure 8).
60. Position the left side steering column cover to the instrument panel (Figure 8).
61. Engage the retaining clips securing the left side steering column cover to the instrument panel (Figure 8).
62. Install the two screws securing the left side steering column cover to the instrument panel (Figure 8).
63. Position the cowl side trim panel (4) to the vehicle (Figure 7).
64. Install the two push pin fasteners (3) securing the cowl side trim panel (Figure 7).
65. Install the screw (2) securing the cowl side trim panel (Figure 7).
66. Position the door sill opening scuff plate (1) to the vehicle then engage the retaining clips (Figure 7).

**Service Procedure [Continued]**

67. Center stack bezel, connect the electrical connectors to the back of the HVAC control panel and engine start button.
68. Position the center stack bezel to the instrument panel (Figure 6).
69. Install the seven screws securing the center stack bezel to the instrument panel (Figure 6).
70. Position the center console bezel and gear shift lever as an assembly to the center console.
71. Screw the gear shift lever onto the transmission shifter shaft.

**NOTE: Be sure that the gear shift lever knob gear shift pattern indicator is correctly orientated before tightening the jam nut.**

72. Reach under the center console bezel to tighten the jam nut that retains the gear shift lever to the transmission shifter shaft (Figure 5).
71. Reach under the center console bezel to connect the cigar lighter electrical connector (Figure 4).
72. Slide the boot over the park brake lever handle while lowering the rear edge of the center console bezel (Figure 4).
73. Reach under the center console bezel to connect the two window switch electrical connectors (Figure 4).

**NOTE: The window switch electrical harness is marked (LT) for Left Side window switch and (RT) for Right Side window switch.**

**Service Procedure [Continued]**

74. Carefully engage the retaining clips securing the center console bezel to the center console (Figure 3).
75. Ensure that the park brake lever handle boot is properly positioned on the park brake lever handle (Figure 4).
76. With the battery negative cable disconnected, connect the wiTECH MicroPod II to the Data Link Connector.
77. Place the ignition in the “**RUN**” position.
78. Exit vehicle with the scan tool.
79. Open the wiTECH Diagnostic application.
80. Enter your “**User id**” and “**Password**” and your “**Dealer Code**”, then select “**Sign In**” at the bottom of the screen. Click “**Accept**”.
81. After checking that no one is inside the vehicle, connect the negative cable to the battery (Figure 2).
82. Install a battery charger and verify that the charging rate provides 13.0 to 13.5 volts. Do not allow the charger to time out during the flash process. Set the battery charger timer (if so equipped) to continuous charge.

**NOTE: Use an accurate stand-alone voltmeter. The battery charger volt meter may not be sufficiently accurate. If voltage reading is too high, apply an electrical load by activating the park or headlamps and/or HVAC blower motor to lower the voltage.**



**Service Procedure [Continued]**

83. Launch the connection wizard screen then select “**Launch DRBIII Enhanced**” at bottom right side of the screen.
84. Click on the box to accept the wiTECH EULA software license agreement then click “**Continue**”.
85. From “**Main Menu**” Select (1) “**DRB III Standalone**”.
86. Under heading “**Stand-Alone Main Menu**”, select (1) “**1998-2010 Diagnostics**”.
87. Select (1) “**ALL (Except Below)**”.
88. Select (6) “**Passive Restraints**”.
89. Select Restraint System screen; select (1) “**Airbag**”.
90. Select Function screen, select (1) “**Read DTCs**”.
91. DTC Type screen; select (1) “**Active**” record any DTCs.
92. DTC Type screen; select (2) “**Stored**” record any DTCs.
93. No DTCs detected; page back to Exit.
  - If there are no ORC module DTCs, continue with **Step 94** of this procedure.
  - If there are ORC module DTCs, make repairs to the ORC module as required, then continue with **Step 94** of this procedure.

**NOTE: If after completing this recall the airbag warning light is still illuminated, the cost to make additional repairs to other airbag system components is the responsibility of the vehicle owner.**

**Service Procedure [Continued]**

94. Turn the ignition to the “OFF” position.
95. Disconnect the wiTECH MicroPod II from the vehicle.
96. Remove the battery charger from the vehicle.
97. Position the battery access cover located in the trunk then install and tighten the five screws securing the cover (Figure 1).
98. Install the lower carpet to the trunk area.
99. Close the rear deck lid.
100. Reset the clock on the radio.
101. Return the vehicle to the customer.
102. Ensure the original ORC module has been rendered unusable and discard.

**Completion Reporting and Reimbursement**

Claims for vehicles that have been serviced must be submitted on the DealerCONNECT Claim Entry Screen located on the Service tab. Claims paid will be used by FCA to record recall service completions and provide dealer payments.

Use the following labor operation number and time allowance:

	<b>Labor Operation Number</b>	<b>Time Allowance</b>
Replace ORC module	08-VE-41-82	1.4 hours

Add the cost of the recall parts package plus applicable dealer allowance to your claim.

**NOTE: See the Warranty Administration Manual, Recall Claim Processing Section, for complete recall claim processing instructions.**

**Dealer Notification**

To view this notification on DealerCONNECT, select “Global Recall System” on the Service tab, then click on the description of this notification.

**Owner Notification and Service Scheduling**

All involved vehicle owners known to FCA are being notified of the service requirement by first class mail. They are requested to schedule appointments for this service with their dealers. A generic copy of the owner letter is attached.

## Vehicle Lists, Global Recall System, VIP and Dealer Follow Up

All involved vehicles have been entered into the DealerCONNECT Global Recall System (GRS) and Vehicle Information Plus (VIP) for dealer inquiry as needed.

GRS provides involved dealers with an updated VIN list of their incomplete vehicles. The owner's name, address and phone number are listed if known. Completed vehicles are removed from GRS within several days of repair claim submission.

To use this system, click on the “**Service**” tab and then click on “**Global Recall System.**” Your dealer's VIN list for each recall displayed can be sorted by: those vehicles that were unsold at recall launch, those with a phone number, city, zip code, or VIN sequence.

**Dealers must perform this repair on all unsold vehicles before retail delivery.** Dealers should also use the VIN list to follow up with all owners to schedule appointments for this repair.

*Recall VIN lists may contain confidential, restricted owner name and address information that was obtained from the Department of Motor Vehicles of various states. Use of this information is permitted for this recall only and is strictly prohibited from all other use.*

## Additional Information

If you have any questions or need assistance in completing this action, please contact your Service and Parts District Manager.

Customer Services / Field Operations  
FCA US LLC

This notice applies to your vehicle,

[Model Year and Model]

VIN XXXXXXXXXXXXXXXXXXXX

VE4/NHTSA 19V-885

LOGO

VEHICLE PICTURE

#### YOUR SCHEDULING OPTIONS

- 1. RECOMMENDED OPTION**  
Call your authorized Chrysler / Dodge / Jeep® / RAM Dealership
- 2. Call the FCA Recall Assistance Center at 1-800-853-1403. An agent can confirm part availability and help schedule an appointment**
- 3. Visit recalls.mopar.com, scan the QR code below, or download the Mopar Owner's Companion App.**

QR Code

Get access to recall notifications, locate your nearest dealer, and more through this website or Mopar Owner's Companion App. You will be asked to provide your Vehicle Identification Number (VIN) to protect and verify your identity. The last eight characters of your VIN are provided above.

#### DEALERSHIP INSTRUCTIONS

Please reference Safety Recall VE4.

# IMPORTANT SAFETY RECALL

## Occupant Restraint Control Module

Dear [Name],

This notice is sent to you in accordance with the National Traffic and Motor Vehicle Safety Act.

FCA US has decided that a defect, which relates to motor vehicle safety, exists in certain [2005 and 2006 Model Year (ZB) Dodge Viper] vehicles.

It is extremely important to take steps now to repair your vehicle to ensure the safety of you and your passengers.

#### WHY DOES MY VEHICLE NEED REPAIRS?

The Occupant Restraint Control (ORC) module on your vehicle <sup>[1]</sup> may inadvertently deploy the airbags and/or seat belt pretensioners. The airbag warning light may or may not precede an inadvertent deployment of the airbags and/or seat belt pretensioners. **Airbags or pretensioners that unexpectedly deploy may cause injury or can cause a vehicle crash without prior warning.**

#### HOW DO I RESOLVE THIS IMPORTANT SAFETY ISSUE?

FCA US will repair your vehicle <sup>[2]</sup> free of charge (parts and labor). To do this, your dealer will replace the ORC module. The estimated repair time is two hours. In addition, your dealer will require your vehicle for proper check-in, preparation, and check-out during your visit, which may require more time. Your time is important to us, so we recommend that you schedule a service appointment to minimize your inconvenience. Please bring this letter with you to your dealership.

**TO SCHEDULE YOUR FREE REPAIR,  
CALL YOUR CHRYSLER, DODGE, JEEP OR RAM DEALER TODAY**

#### WHAT IF I ALREADY PAID TO HAVE THIS REPAIR COMPLETED?

If you have already experienced this specific condition and have paid to have it repaired, you may visit [www.fcarecallreimbursement.com](http://www.fcarecallreimbursement.com) to submit your reimbursement request online. <sup>[3]</sup> Once we receive and verify the required documents, reimbursement will be sent to you within 60 days. If you have had previous repairs performed and/or already received reimbursement, you may still need to have the recall repair performed.

We apologize for any inconvenience, but are sincerely concerned about your safety. Thank you for your attention to this important matter.

Customer Assistance/Field Operations  
FCA US LLC



**Mr. Mrs. Customer**  
**1234 Main Street**  
**Hometown, MI 48371**

[1] If you no longer own this vehicle, please help us update our records. Call the FCA Recall Assistance Center at 1-800-853-1403 to update your information.

[2] If your dealer fails or is unable to remedy this defect without charge and within a reasonable time, you may submit a written complaint to the Administrator, National Highway Traffic Safety Administration, 1200 New Jersey Ave., S.E., Washington, DC 20590, or you can call the toll-free Vehicle Safety Hotline at 1-888-327-4236 (TTY 1-800-424-9153), or go to [safercar.gov](http://safercar.gov).

[3] You can also mail in your original receipts and proof of payment to the following address for reimbursement consideration: FCA Customer Assistance, P.O. Box 21-8004, Auburn Hills, MI 48321-8007, Attention: Recall Reimbursement.

Note to lessors receiving this recall notice: Federal regulation requires that you forward this recall notice to the lessee within 10 days.