



Thor Motor Coach Recall Repair Instructions

Recall #	19V-799 2019-560		
Description/Title:	Diesel Rear Reflector		
Affected Product Line(s):	Certain model 2013 through 2018 Tuscany, 2014 through 2017 Tuscany XTE and 2016 through 2020 Venetian motorhomes		
Service Campaign # :	RC000180	Released Date:	12/16/2019
Repair Code:	TMCRC80487V	Document Date:	12/16/2019
Time Allowed:	0.10	Document Revision:	A

Issue:

On certain model 2013 through 2018 Tuscany, 2014 through 2017 Tuscany XTE and 2016 through 2020 Venetian motorhomes, the rear reflectors are not in the proper position per FMVSS 108.

Without the reflectors in the required position, the motorhome may be less visible to other drivers, increasing the risk of an accident and/or property damage.

Parts Required:

Four (4) Self-Adhesive Reflector Stickers (Supplied in recall notification mailing)

If you are in need of a replacement mailing of reflectors, please contact our Recalls Dept. at Recalls@TMCRV.com.

Instructions:

1. Clean area of rear cap so it is free of dirt and debris.
2. On the rear of the coach, measure 30" up from the bottom of the rear cap as depicted in Figure 1 on both sides of the rear cap.
3. After measuring, place one adhesive reflector on each side of the rear cap which should be just under the taillight lens as depicted in Figure 2.
4. On the side, from the bottom of the rear cap, measure up 6" and place one adhesive reflector on each side of the rear cap and align it with the trim molding as depicted in Figure 2.



Thor Motor Coach Recall Repair Instructions

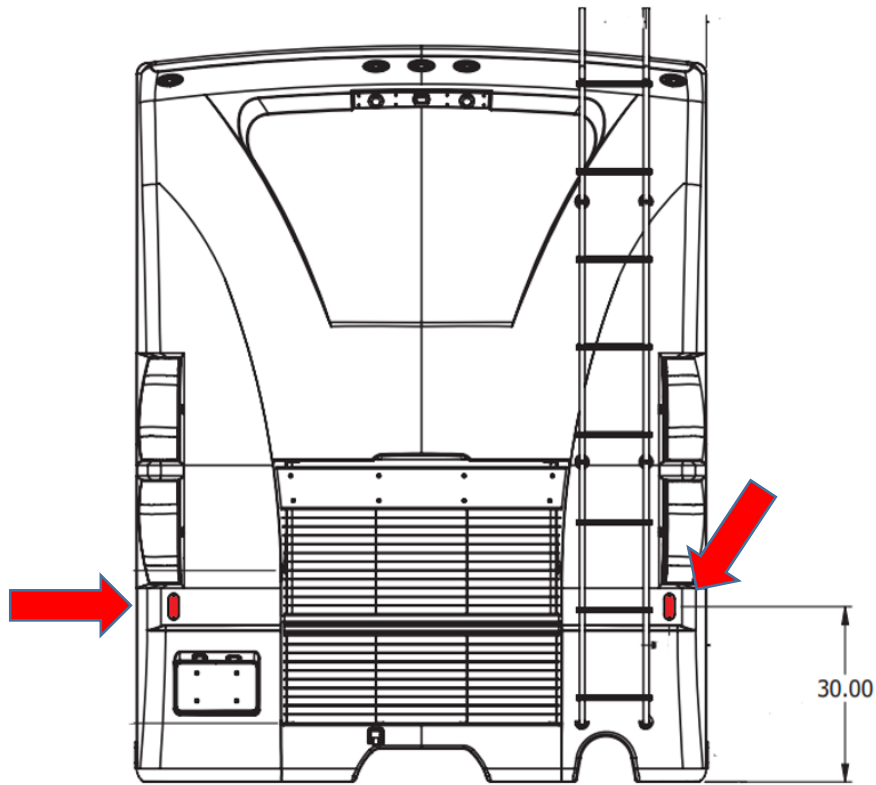

Figure 1

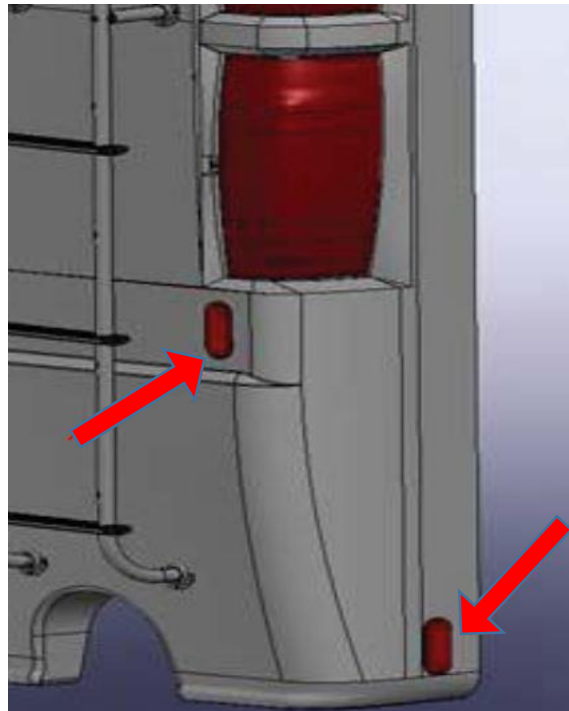

Figure 2

Thor Motor Coach
1-877-500-1020
NHTSA Recall # 19V-799
Transport Canada Recall # 2019-560