



FIELD KIT

VAC-TRON EQUIPMENT LLC

Trenchless
27137 S. Hwy 33
Okahumpka, FL 34762 USA

FIELD CAMPAIGN KIT # VVK000002

DATE:

06 December 2019

Service Bulletin # SVV2020-003

AXLE RELOCATION KIT

CAMPAIGN TYPE:

Mandatory-Product Safety

CAMPAIGN CATEGORY:

Kit and Bulletin

MACHINE / ATTACHMENT MODEL(S):	Serial Numbers		Kit Version
	Included	Excluded	
LP873SDT	See attached listing on pages 20-23 of this Field Kit for specific VIN and Serial/Unit numbers	N/A	VVK01
LP873SGT			
LP873XDT			
LPSDT			
LPSGT			
LPXDT			
MC873SDT			
MINICOMBO			



PRODUCT SAFETY ALERT

PURPOSE:

VACUUM EXCAVATOR SIDE-TO-SIDE SWAY POSSIBLE

While towing a vacuum excavator with a loaded debris tank and at highway speeds greater than 40 mph (64 kph), the vacuum excavator may cause unpredictable side-to-side swaying behind the towing vehicle.

DEATH OR SERIOUS INJURY POSSIBLE

When towing the vacuum excavator on public roadways, **death or serious injury** may result due to loss of control of the vacuum excavator and towing vehicle. Property or equipment damage may also occur.

IMMEDIATE MACHINE MODIFICATIONS REQUIRED

VVK00-0002 has been created to provide the necessary parts and instructions to relocate the axle(s) rearward to redistribute the weight. **This kit must be installed as soon as possible.**

SPECIAL TOOLS AND CONDITIONS:

- **Suitable lifting device capable of lifting approximately 390 lb (177 kg)**



WARNING: Pressurized fluid can penetrate body tissue and result in death or serious injury. Leaks can be invisible. Keep away from any suspected leak. Relieve pressure in the hydraulic system before searching for leaks, disconnecting hoses, or performing any other work on the system. If you must pressurize the system to find a suspected leak, use an object such as a piece of wood or cardboard rather than your hands. When loosening a fitting where some residual pressure may exist, slowly loosen the fitting until oil begins to leak. Wait for leaking to stop before disconnecting the fitting. Fluid injected under the skin must be removed immediately by a surgeon familiar with this type of injury.



WARNING: Failure to use shutdown procedure can result in unexpected hazard(s). Death or serious injury could result due to entanglement, crushing, cutting, or other hazardous contact. Follow Shutdown Procedure after operating, before performing any service or maintenance, and before transporting.

Shutdown Procedure

STOPPING THE MACHINE

For your safety and the safety of others, follow shutdown procedure before working on the machine for any reason, including servicing, maintaining, cleaning, inspecting, unclogging or transporting machine, or as otherwise directed in Operator's manual.

Step 1: Make sure end of vacuum hose is clear of all spoils, debris, and other materials.

Step 2: Turn *Water Pump Switch* to OFF.

Step 3: Push *Throttle Switch* to SLOW. Idle engine five minutes to allow vacuum pump to cool down. This helps to prevent the buildup of condensation.

Step 4: Turn *Key Switch* to OFF to shut off engine. Remove the key.

Step 5: Pull trigger on any high-pressure water tool to relieve line pressure.

Step 6: Disassemble all water line connections, vacuum hoses, and tools. Stow properly on machine.

Step 7: Drain CVS Filter Housing / Cyclone.



WARNING: Do not point high pressure water tool in the direction of people when relieving the pressure.

PROCEDURE:



WARNING: Raised load can shift or fall. Death or serious injury could be possible if struck or crushed by falling load. Never allow anyone under a raised load unless load is securely supported to prevent it from shifting or falling.

1. Ensure the debris tank and water tanks are empty. Use suitable blocking to ensure the trailer does not shift or fall while work is performed. LP 873 trailers weigh approximately 8,500 lb (3855 kg), MC 873 trailers weigh approximately 9,500 lb (4310 kg).
2. Disconnect the control panel located inside the engine enclosure door on the curb side.

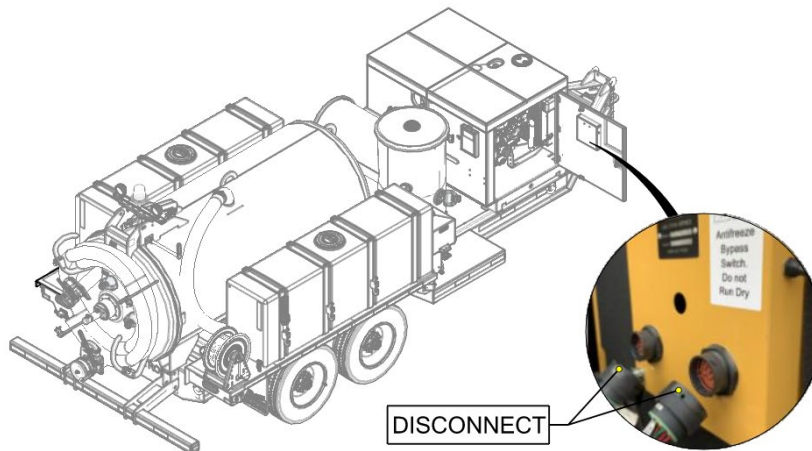

3. Disconnect wires from the positive battery terminal located inside the engine enclosure on the street side.

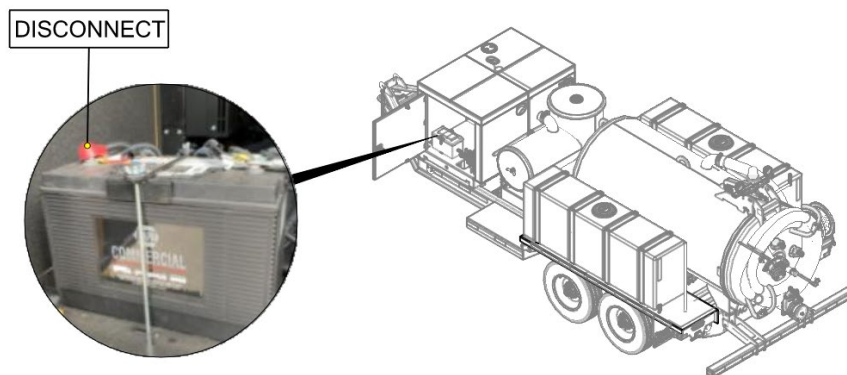

4. Remove the conspicuity tape located on the fenders below the water tanks on both sides of the trailer (Curbside shown).

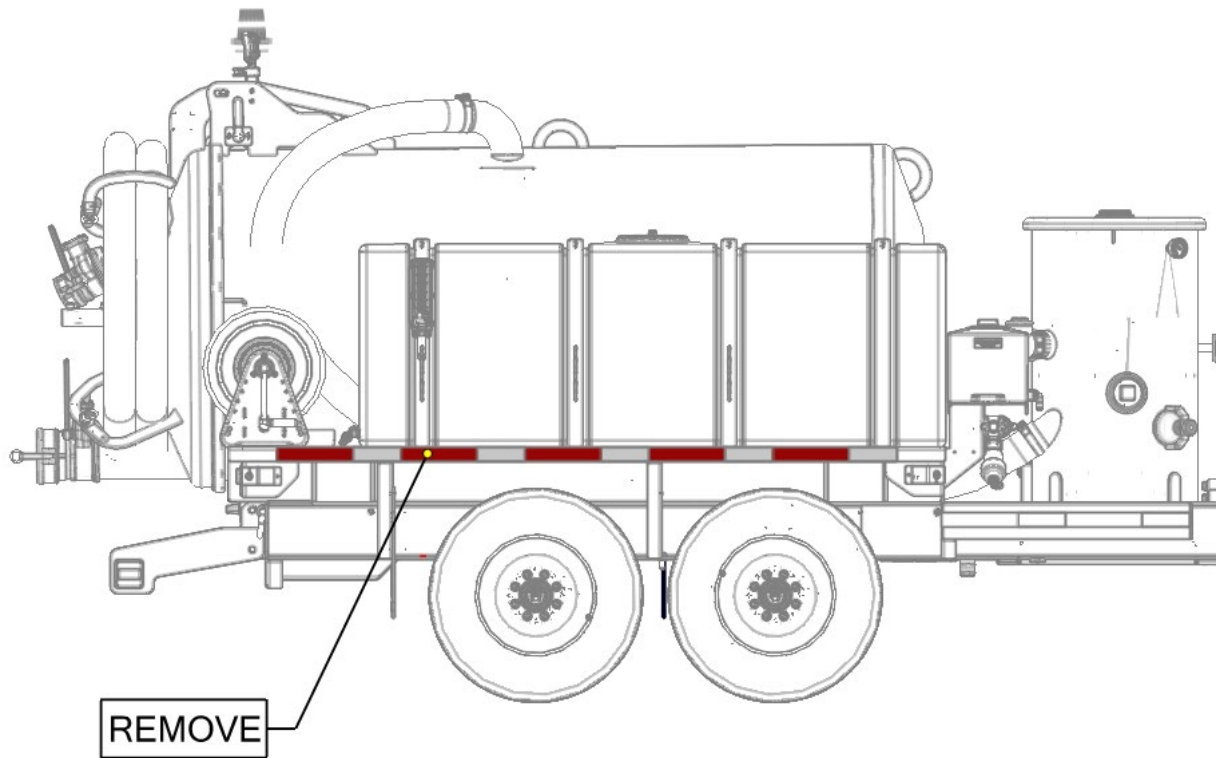

5. Use a 1/2" (12.7 mm) socket to remove the (8) tank strap ties. Retain tank strap ties and fasteners for future installation.

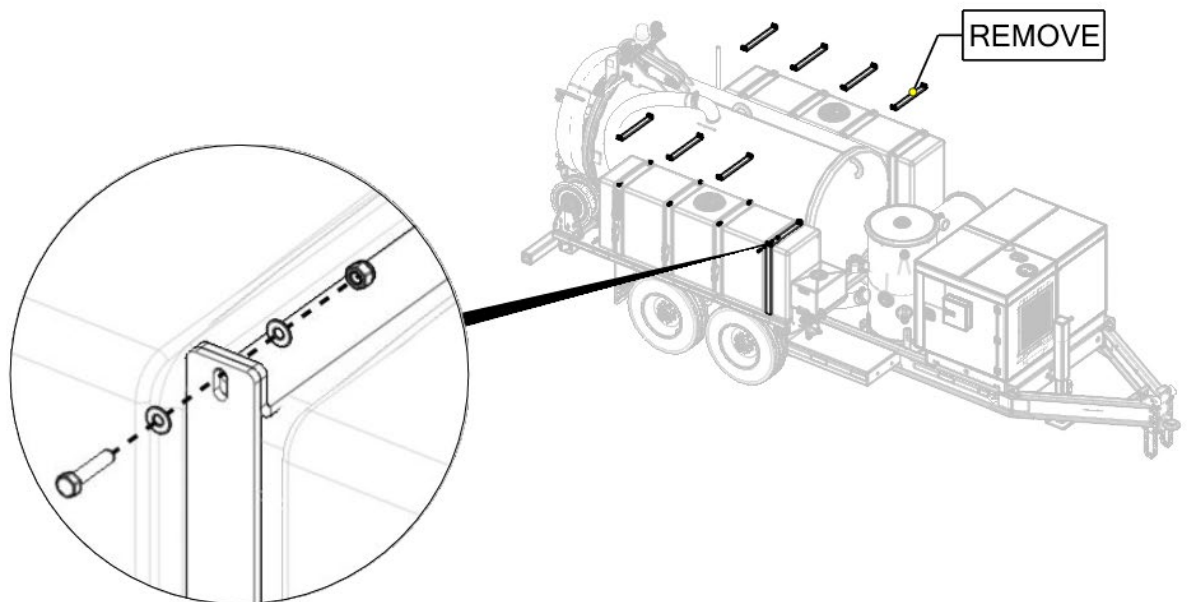

6. Remove the water tanks. Use a suitable lifting device. Empty water tank weighs approximately 90 lb (41 kg).

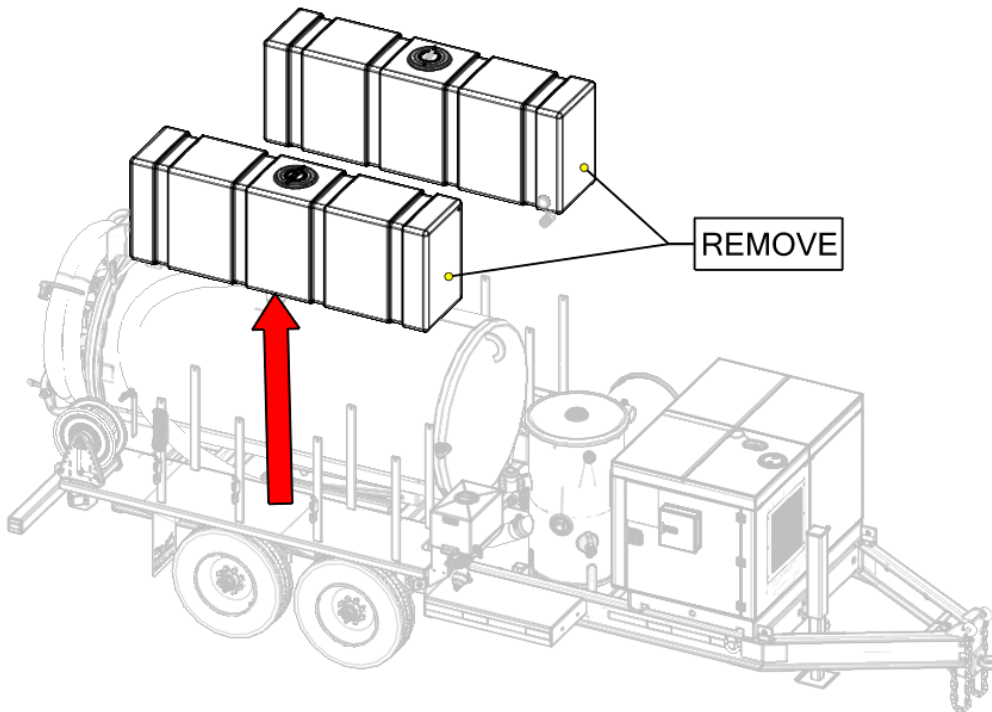

7. Use suitable lifting device. LP 873 trailers weigh approximately 8,500 lb (3855 kg), MC 873 trailers weigh approximately 9,500 lb (4310 kg). Use suitable blocking.

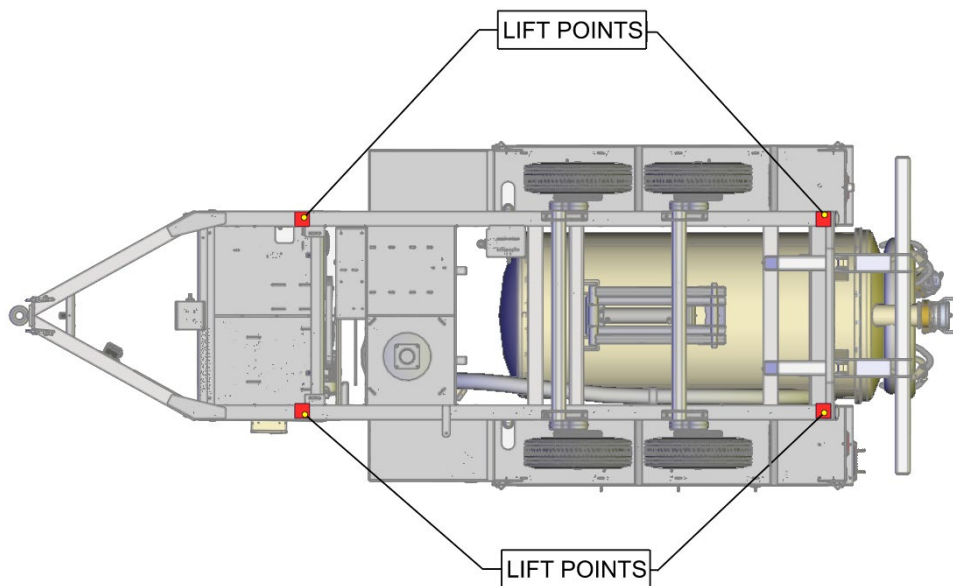

8. Use a 1-1/8" socket to loosen (32) lug nuts and remove all (4) tires. Retain lug nuts for future installation. Use a suitable lifting device. Wheels weigh approximately 55 lb (25 kg).

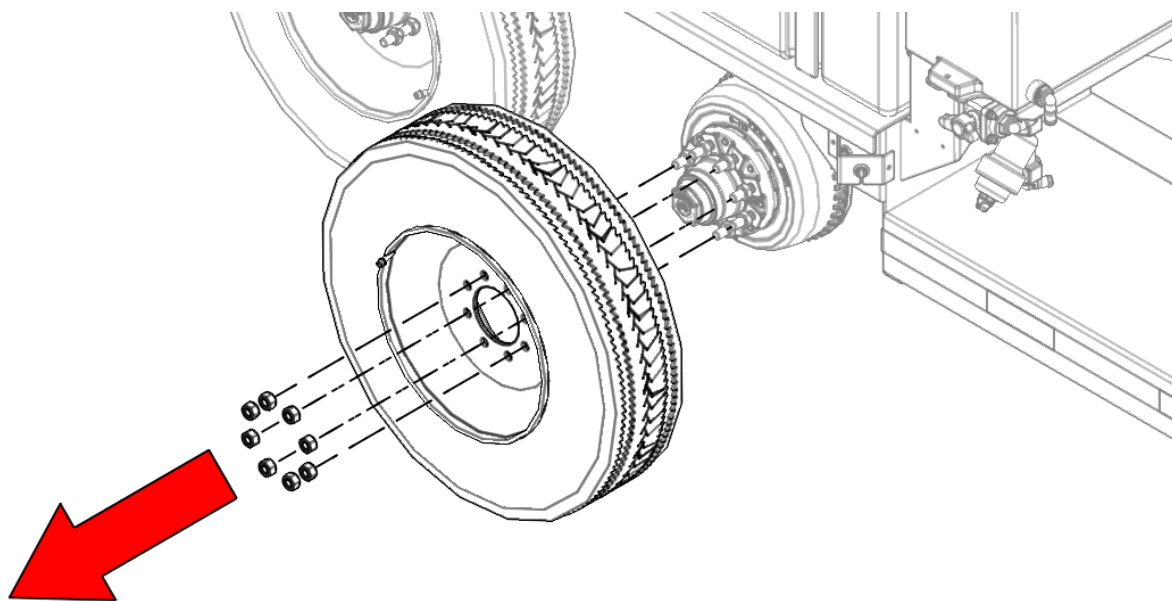

9. Use a 3/8" (9.5 mm) socket to remove the mud flaps from both sides of the trailer (Curb Side shown). Retain the fastening hardware and mud flaps for future installation.

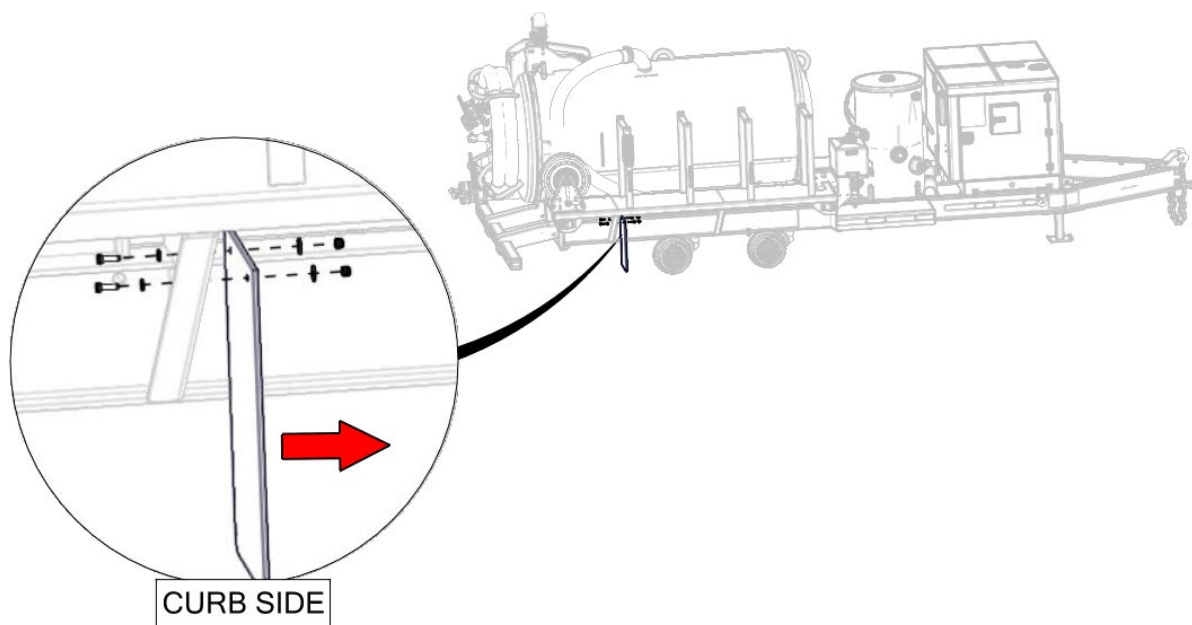

10. Disconnect the brake light and marker light wiring from both sides of the trailer. Disconnect the license plate light on the street side of the trailer.

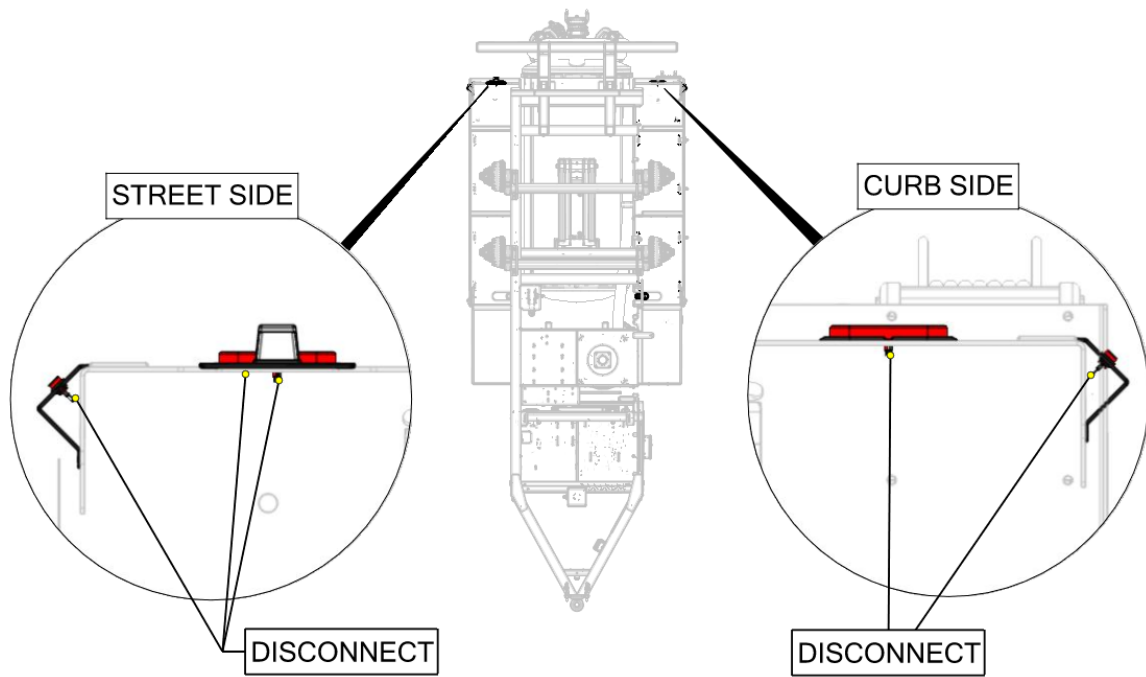

11. Pull the disconnected light wires through the I-beam and place on the fender platform to prevent damage from the upcoming torch cutting and welding operations.

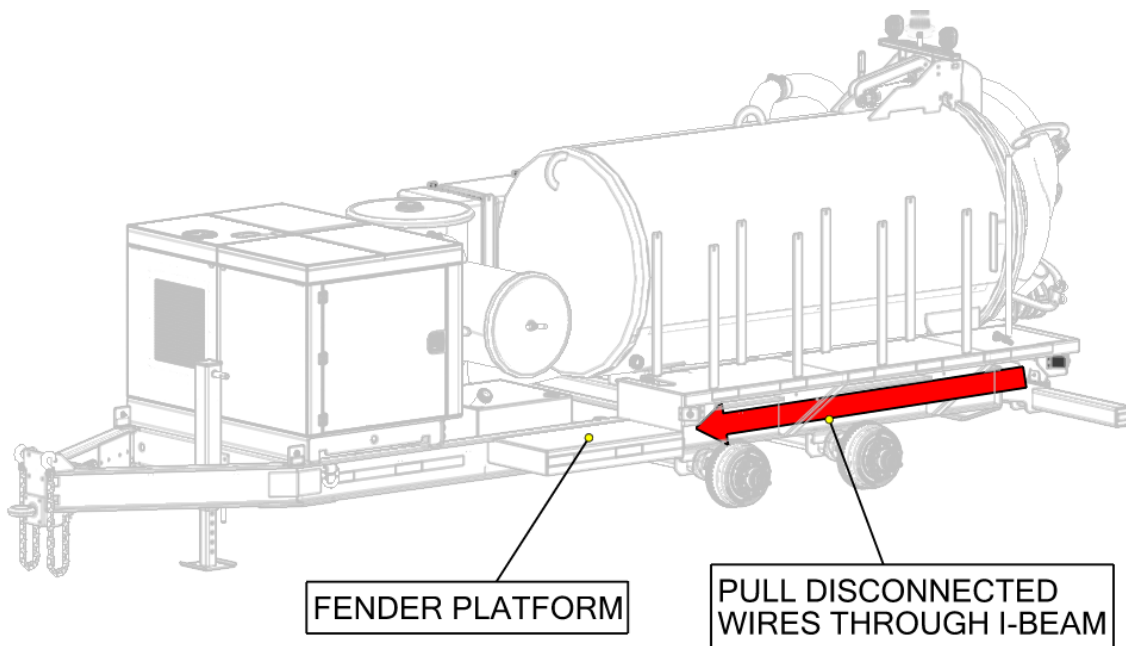

12. Pull remaining hoses and wires away from the I-beam on the street side. Use blocks of wood to keep the hoses and wires from contacting the I-beam and prevent damage from heat generated by torch cutting and welding operations.

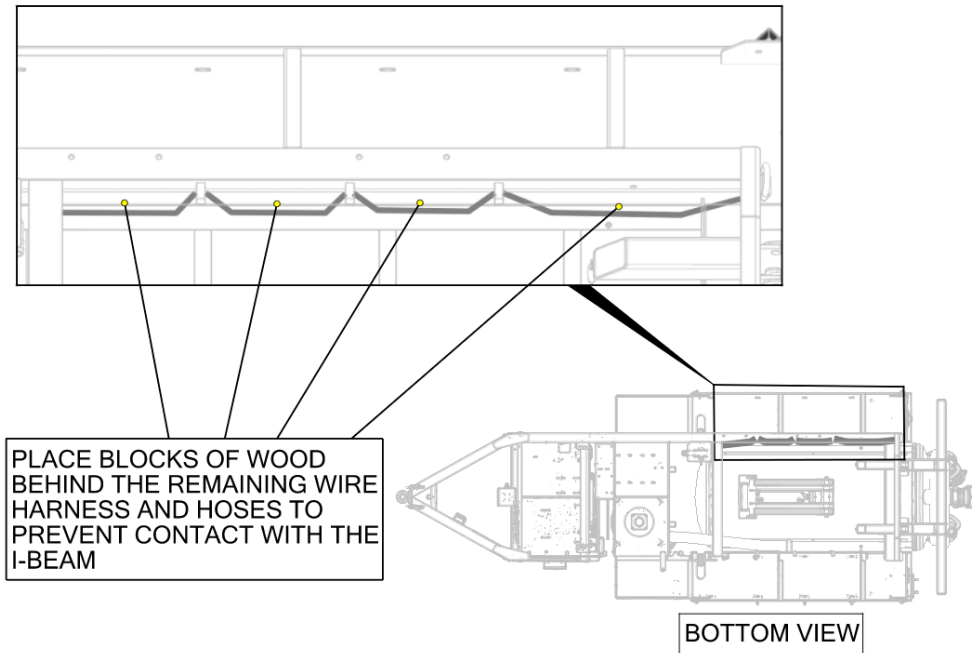

13. Disconnect the wires from each brake drum.

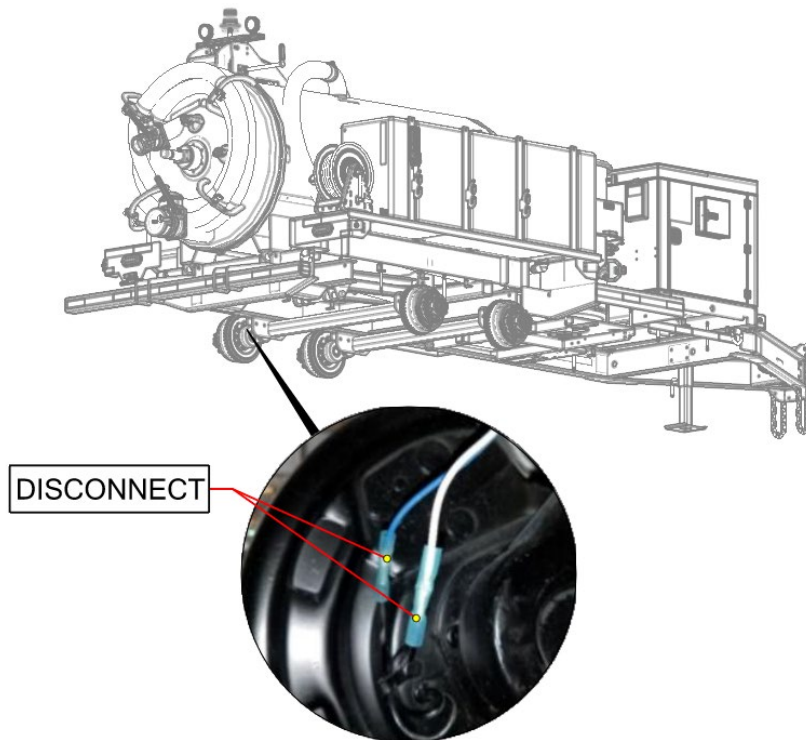

14. Use a 15/16" (24 mm) socket to remove the axles from the trailer. Retain hardware for future installation. Use suitable lifting device for each axle. Each axle weighs approximately 390 lb (177 kg)

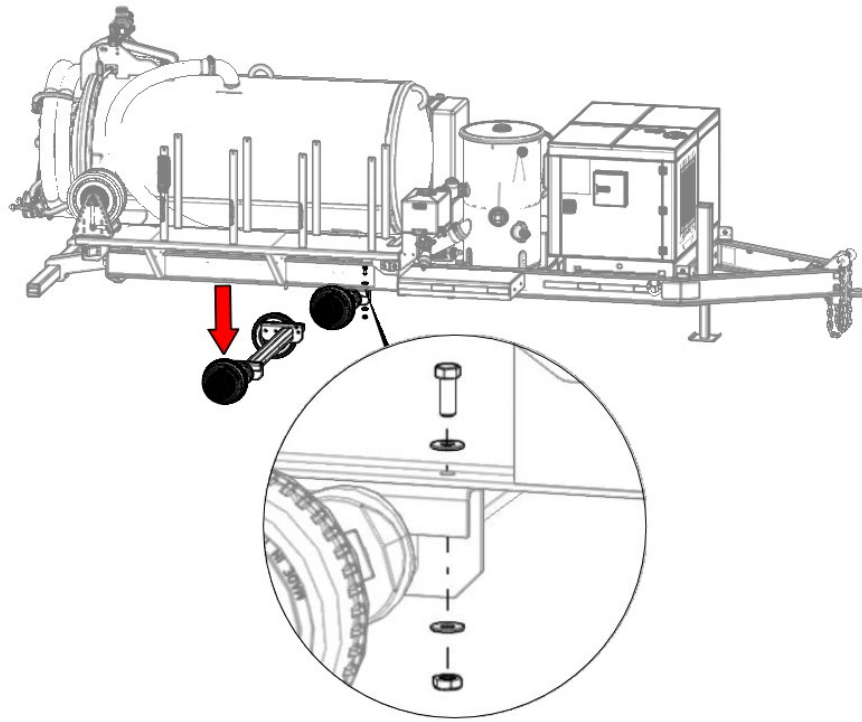

15. Use a cutting torch to remove the (4) gussets from both sides of the trailer (Curb Side shown). Grind away residual slag from the trailer frame.

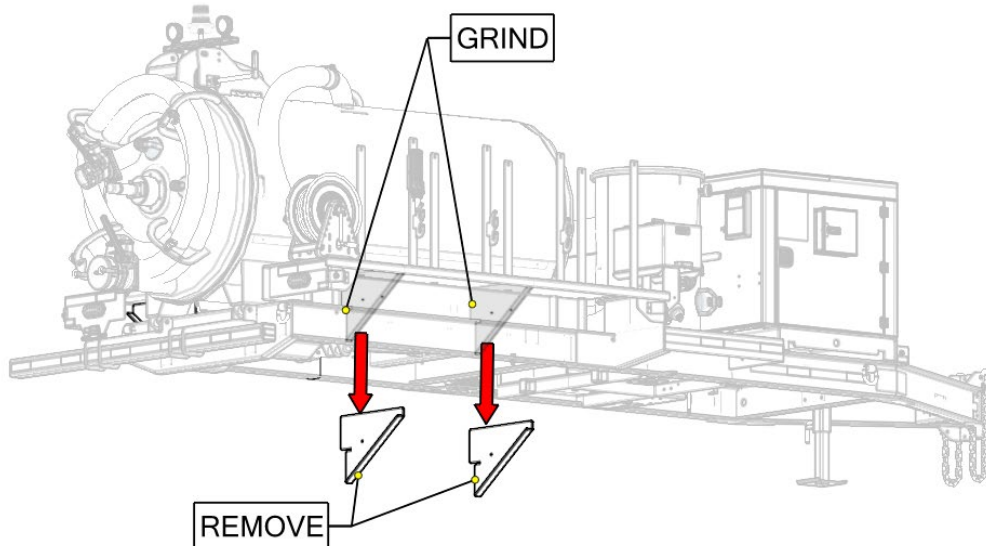

16. Measure and drill new axle bracket holes through the bottom of the I-beam on both sides of the trailer as shown.

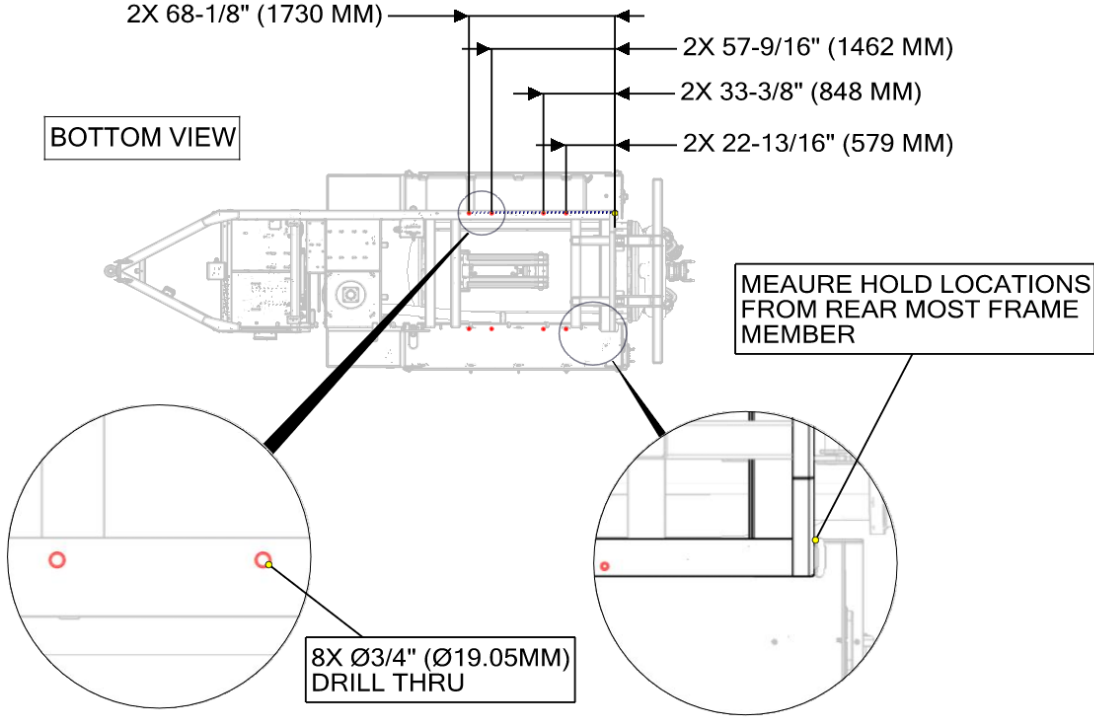

17. Measure for new gusset locations and weld as shown on both sides of the trailer.
Ref 1 and 2, Fig. 1.

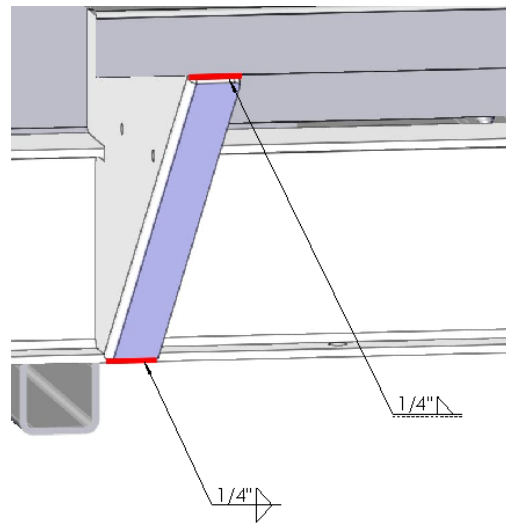
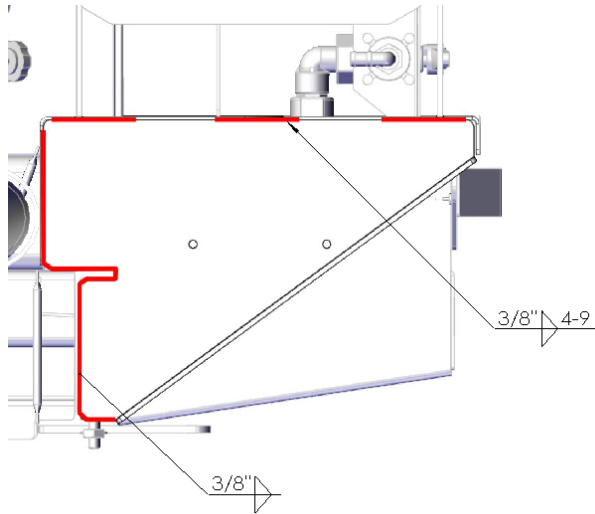
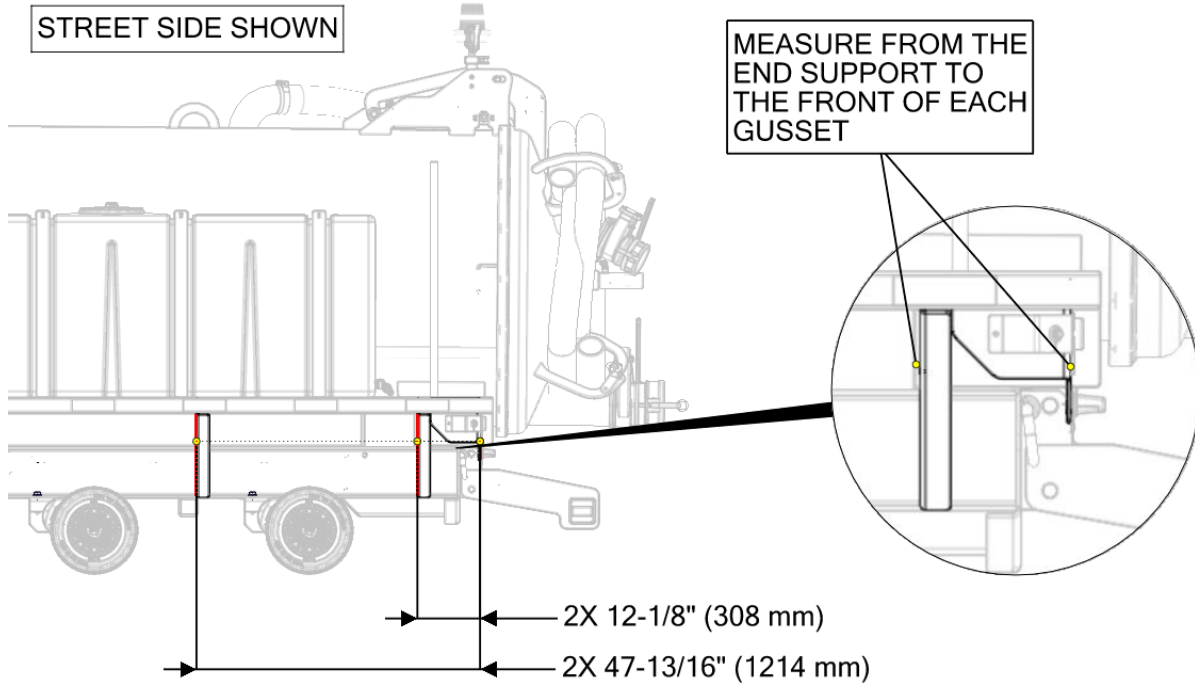

18. Weld on the 3" scissor tube as shown, Ref. 3, Fig. 1.

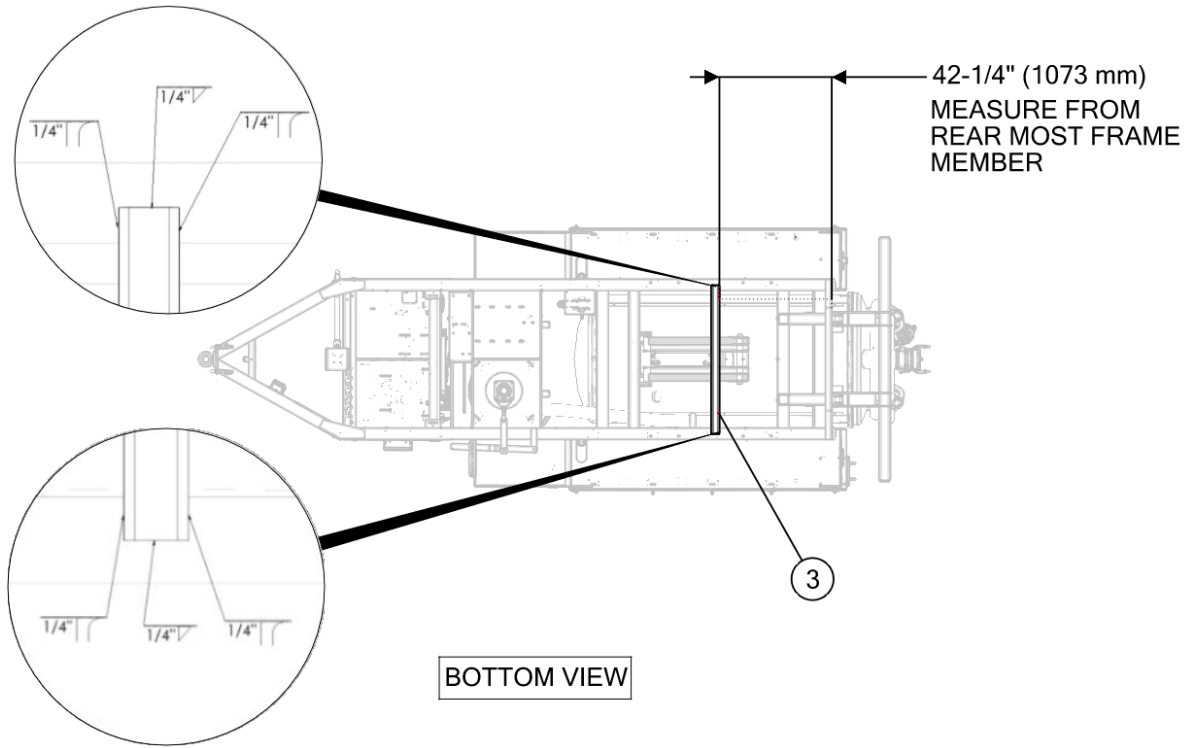

19. Grind all welds and weld splatter. Clean all surfaces on the I-beam, gussets, scissor bar, and fenders. Paint all exposed surfaces. Allow paint to dry thoroughly.

20. Use a 15/16" (24 mm) socket with the fasteners retained from Step 13 to attach the axles in the new locations. Use a suitable lifting device for lifting axles. Each axle weighs 390 lb (177 kg).

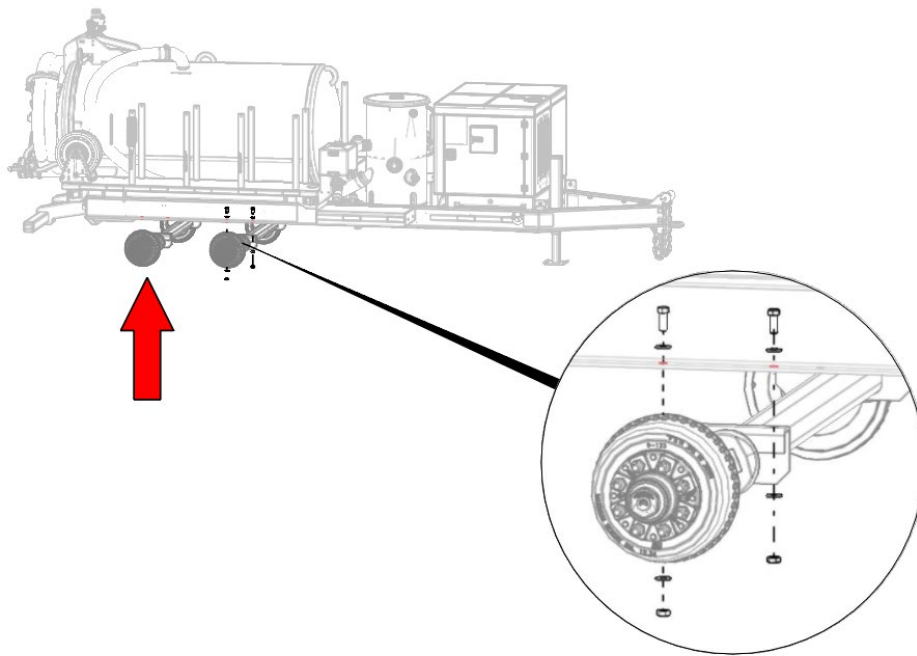

21. Reconnect brake wires using heat shrink butt connectors Ref. 4, Fig. 1.

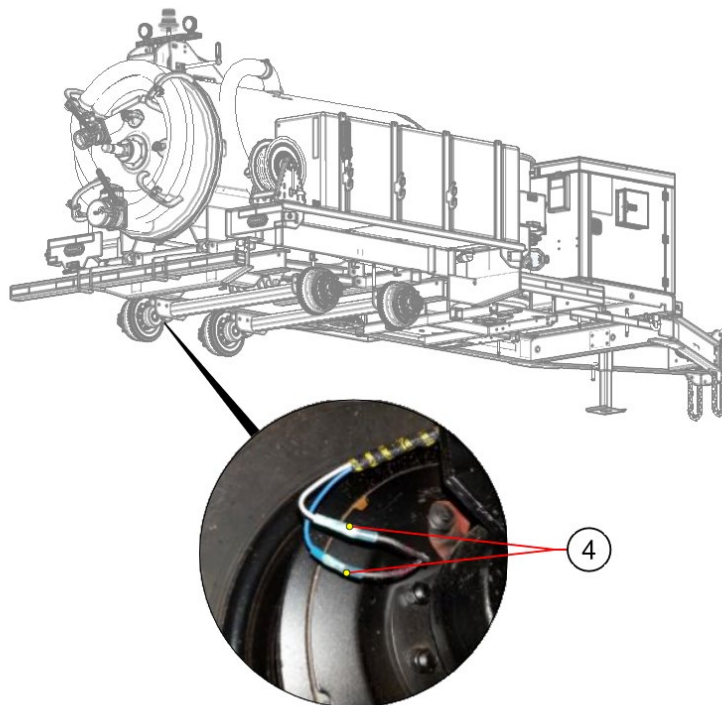

22. Use a 1-1/8" socket and the lug nuts retained from Step 7 to reinstall all (4) tires. Tighten lug nuts to a max torque of 325 ft-lb (441 Nm).

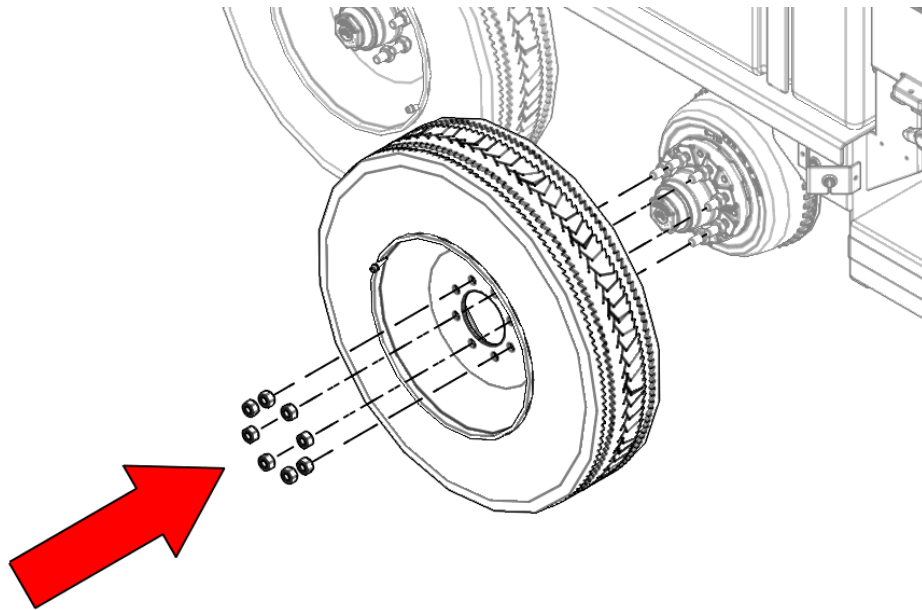

23. Reinstall the mud flaps on both sides of the trailer using the hardware retained from Step 8.

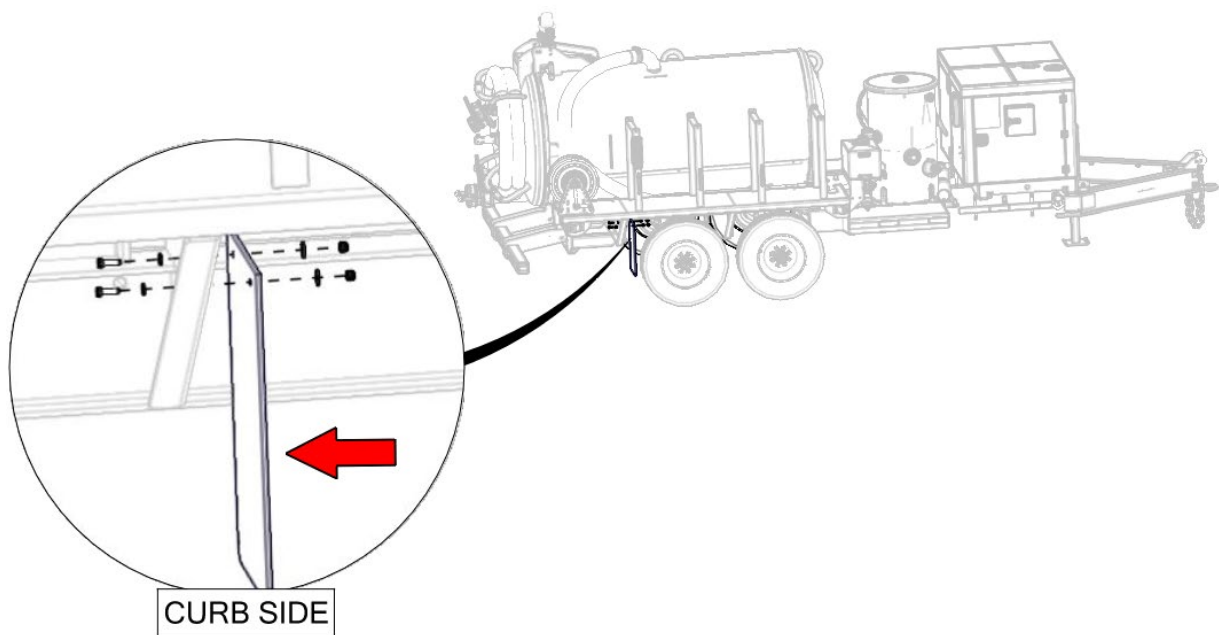

24. Remove the wooden blocks from behind the hoses and wires in the street side I-beam

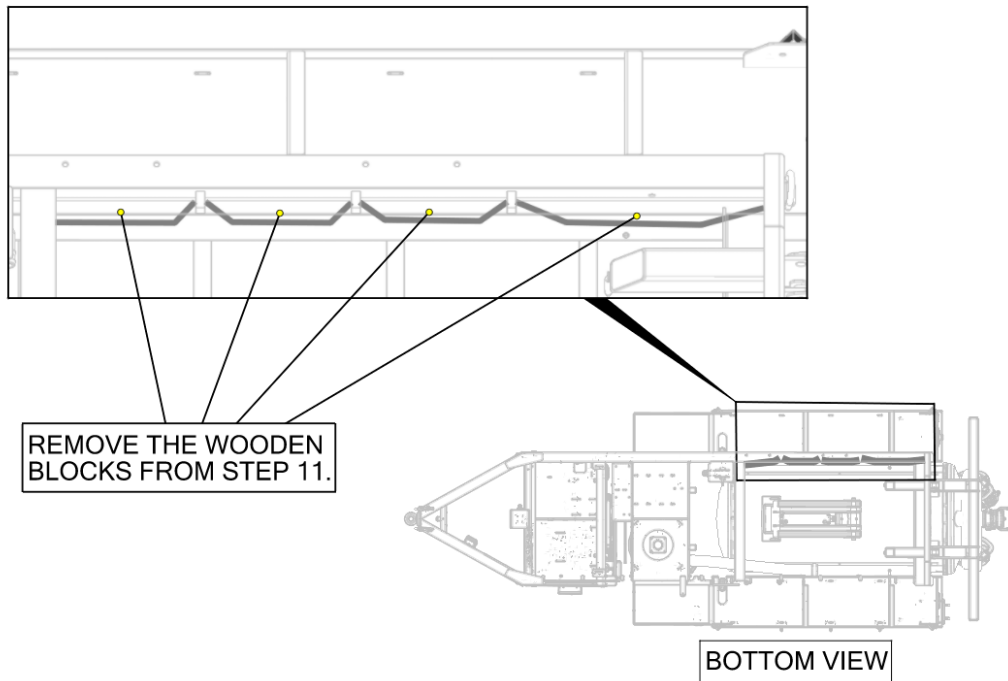

25. Feed the brake light, marker light, and license plate wires back through the I-beam on both sides of the trailer. Zip tie excess wire to the main wire harness Ref 5, Fig 1.

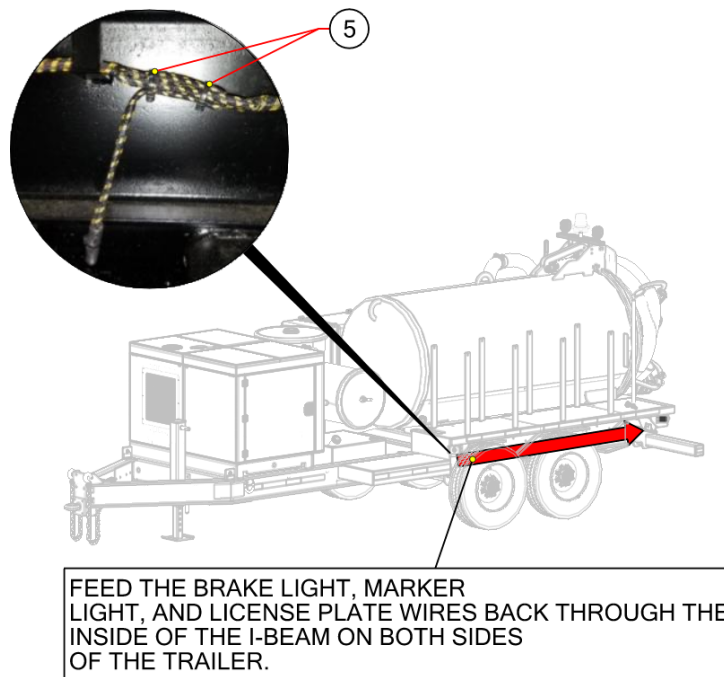

26. Reconnect the brake light, marker light, and license plate wires using heat shrink butt connectors. Ref. 4, Fig. 1.

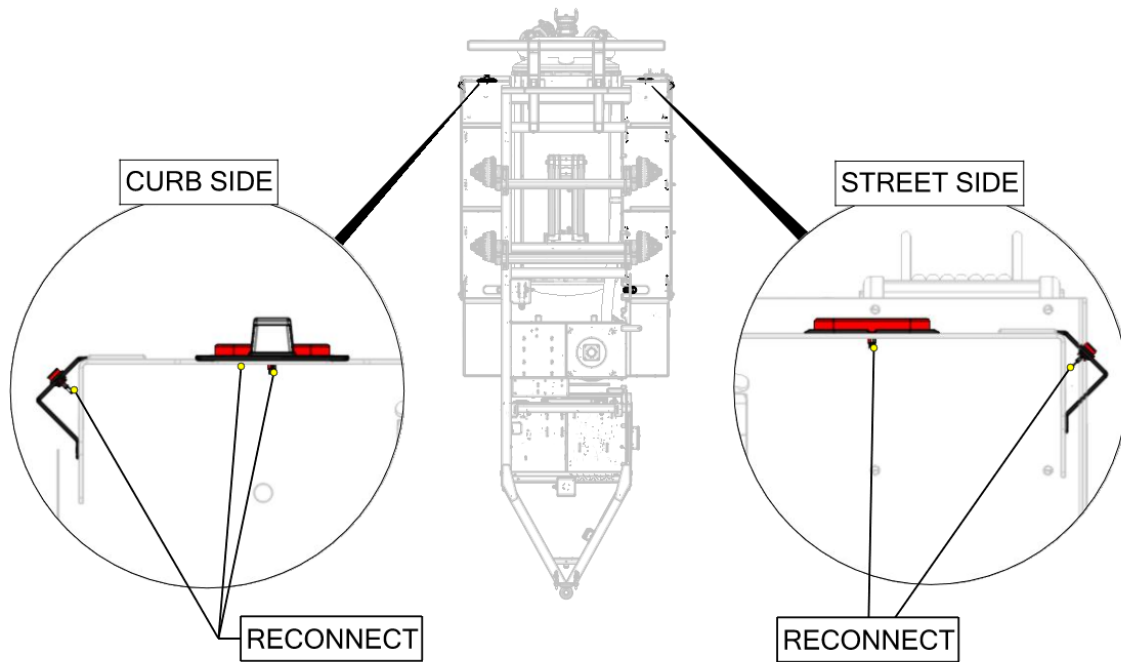

27. Clean area where the conspicuity tape will be installed with light soap and water. Reinstall the conspicuity tape on fenders on both sides of the trailer (curbside shown) Ref 6, Fig. 1.

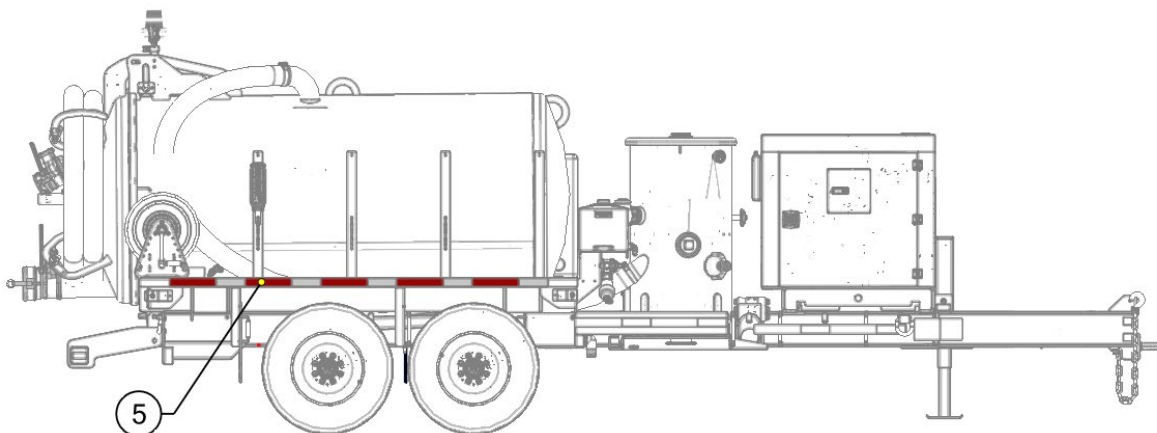

28. Place the (2) water tanks back into position on the fenders.

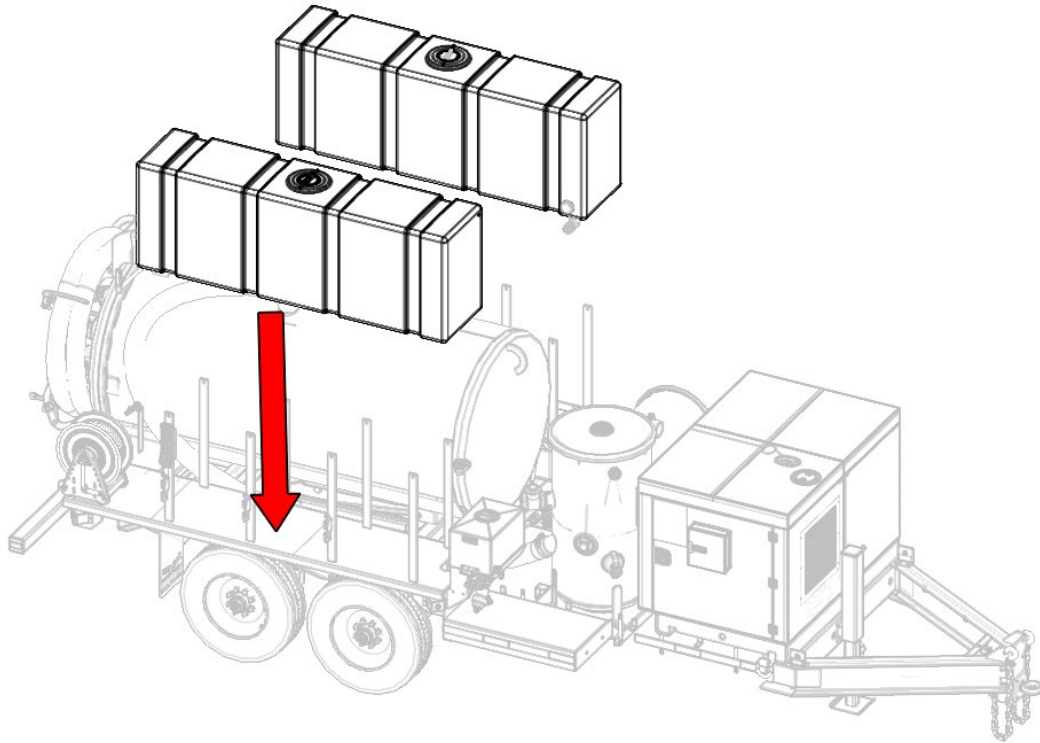

29. Reinstall the (8) water tank strap ties with the hardware retained from Step 5.

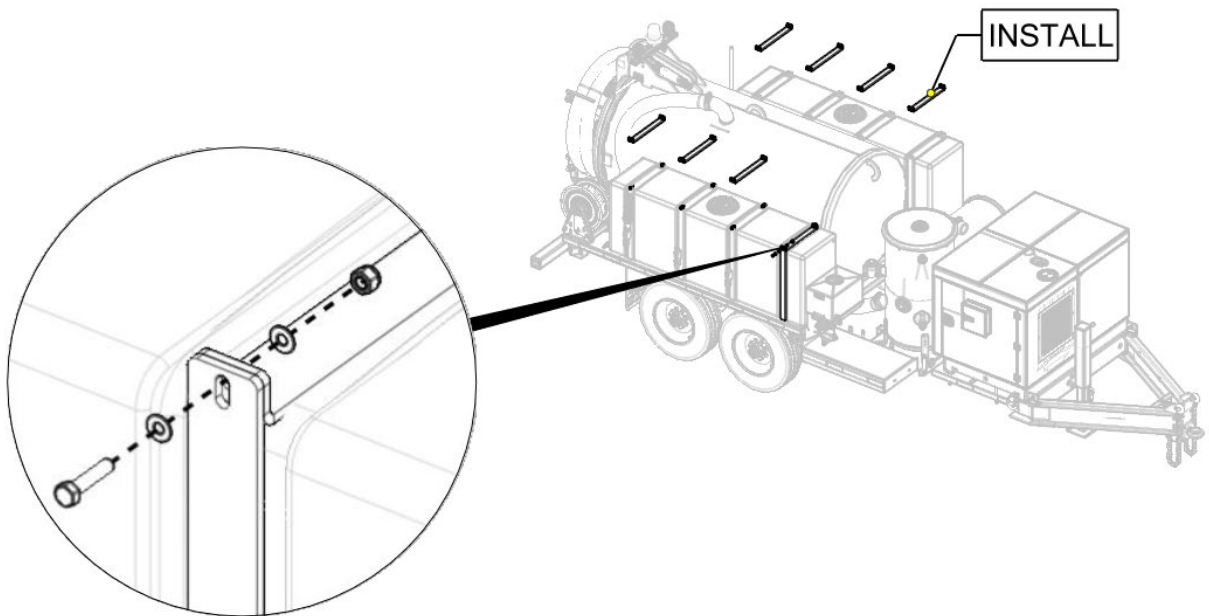

30. Reconnect wires to the positive battery terminal.

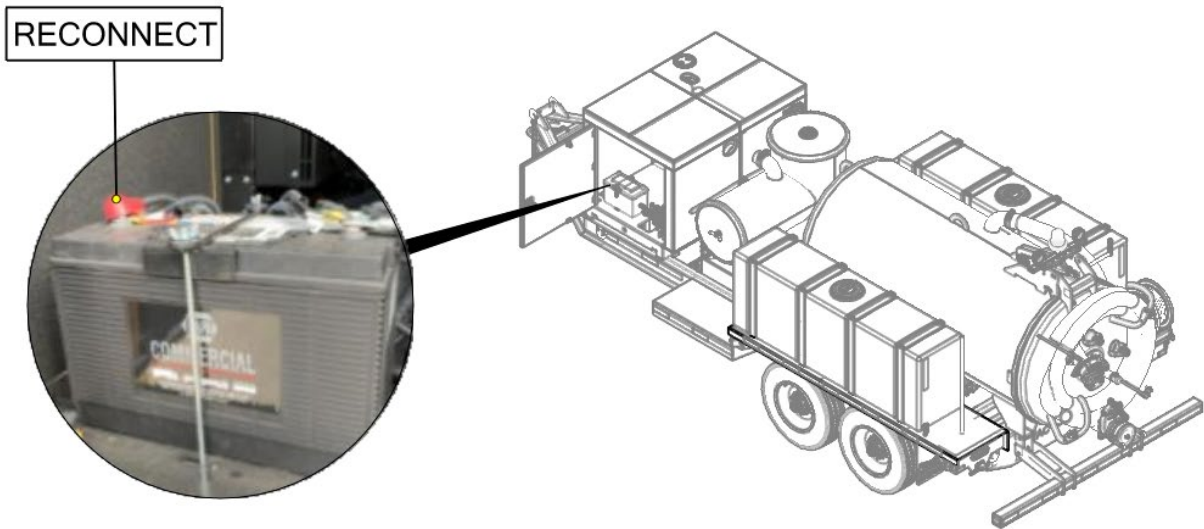

31. Reconnect the Control Panel.

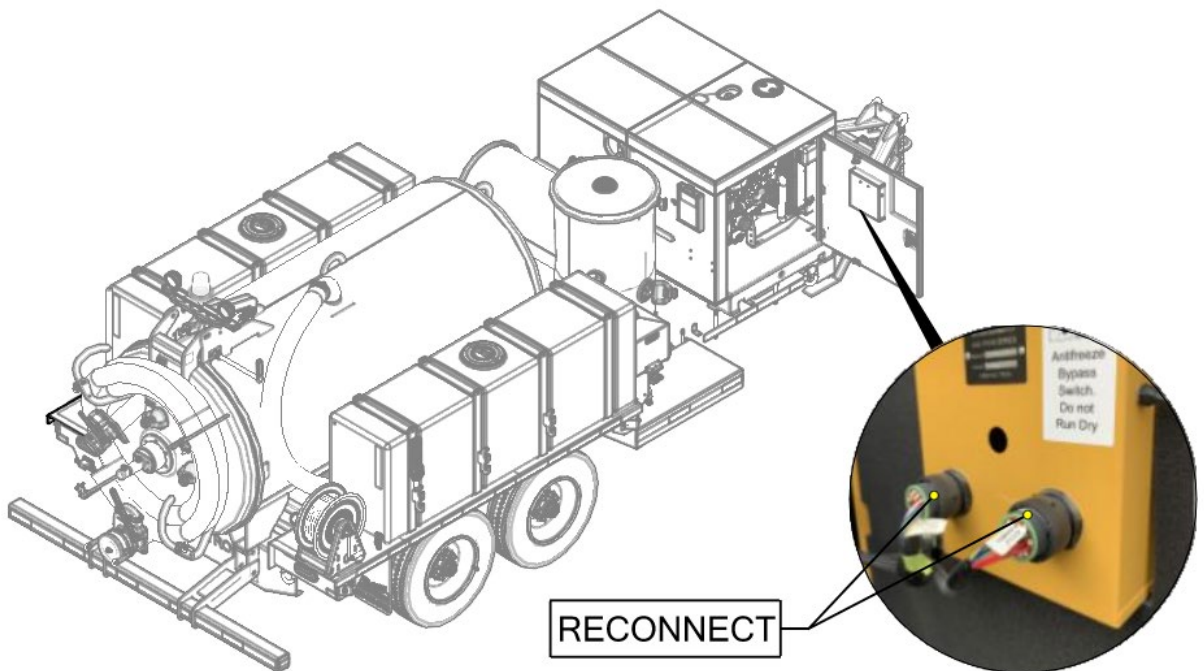

AFFECTED MACHINES – VVK01-0002

MODEL	VIN	SERIAL/UNIT	MODEL	VIN	SERIAL/UNIT
LP873SGT	5HZBF1929FLGF2138	151172	LP873SGT	5HZBF192XGLLG2182	161333
LP873SDT	5HZBF192XFLLF2170	151269	MC873SDT	5HZBF1926GLLG2180	161336
LP873SDT	5HZBF1921FLLF2171	151272	LP873SDT	5HZBF1921GLLG2183	161352
LP873SDT	5HZBF1923FLLF2172	151273	LP873SDT	5HZBF1925HLLG2186	171010
LP873SDT	5HZBF1923FLMF2174	151274	LP873SDT	5HZBF1927HLLG2187	171011
LP873SDT	5HZBF1925FLMF2175	151277	LP873SDT	5HZBF1929HLLG2188	171012
LP873SDT	5HZBF1927GLMF2177	161018	LP873SDT	5HZBF1920HLLG2189	171013
LP873SDT	5HZBF1929GLMF2178	161019	LP873SDT	5HZBF1927HLLG2190	171014
LP873SDT	5HZBF1920GLMF2179	161020	LP873SDT	5HZBF1929HLAH2102	171032
LP873SDT	5HZBF1927GLMF2180	161021	LP873SDT	5HZBF1920HLAH2103	171033
LP873SDT	5HZBF1927GLAG2103	161036	MC873SDT	5HZBF1926HLAH2106	171038
LP873SDT	5HZBF1920GLAG2105	161042	LP873SDT	5HZBF1923HLAH2113	171077
LP873SDT	5HZBF1929GLBG2106	161043	LP873SDT	5HZBF1920HLBH2119	171084
LP873SDT	5HZBF1920GLBG2107	161044	LP873XDT	5HZBF1922HLBH2123	171089
LP873SGT	5HZBF1922GLBG2108	161047	LP873SDT	5HZBF1929HLBH2121	171092
LP873XDT	5HZBF1929GLAG2104	161051	LP873SDT	5HZBF1920HLBH2122	171093
LP873SDT	5HZBF1926GLBG2113	161064	LP873SDT	5HZBF1927HLBH2120	171104
LP873SDT	5HZBF1928GLBG2114	161065	LP873SDT	5HZBF1922HLCH2125	171119
LP873SDT	5HZBF192XGLCG2117	161077	MC873SDT	5HZBF1921HLGH2192	171143
MC873SDT	5HZBF1921GLCG2118	161083	LP873SDT	5HZBF1928HLDH2147	171159
LP873XDT	5HZBF1929GLDG2127	161108	LP873SDT	5HZBF1924HLCH2126	171161
MC873SDT	5HZBF1920GLDG2128	161113	LP873SDT	5HZBF1926HLCH2127	171162
LP873SDT	5HZBF1925GLDG2125	161115	LP873SDT	5HZBF1921HLEH2154	171170
LP873SDT	5HZBF1927GLDG2126	161116	LP873SDT	5HZBF392XHLEH2353	171178
LP873SDT	5HZBF1920GLFG2149	161182	LP873SDT	5HZBF192XHLEH2170	171179
LP873SDT	5HZBF1927GLFG2150	161185	LP873SDT	5HZBF1927HLEH2160	171187
LP873SDT	5HZBF1929GLFG2151	161188	LP873SDT	5HZBF1924HLDH2145	171193
LP873SDT	5HZBF1920GLFG2152	161189	LP873SDT	5HZBF1926HLDH2146	171194
LP873SDT	5HZBF1922GLFG2153	161204	LP873SDT	5HZBF192XHLDH2148	171195
LP873SDT	5HZBF1922GLHG2160	161243	LP873SDT	5HZBF1921HLDH2149	171196
LP873SGT	5HZBF1924GLHG2161	161244	LP873SDT	5HZBF192XHLEH2167	171230
LP873SGT	5HZBF1926GLHG2162	161245	LP873SDT	5HZBF1921HLEH2168	171231
LP873SGT	5HZBF1928GLHG2163	161263	LP873SGT	5HZBF192XHHLGH2174	171233
LP873SGT	5HZBF1924GLJG2169	161275	LP873SDT	5HZBF1922HLDH2144	171234
LP873SGT	5HZBF1920GLJG2170	161276	LP873SDT	5HZBF1921HLGH2175	171235
LP873SDT	5HZBF1922GLJG2171	161280	LP873SDT	5HZBF1929HLEH2161	171269
LP873SGT	5HZBF1924GLJG2172	161282	LP873SGT	5HZBF1925HLGH2177	171293
LP873SGT	5HZBF1928GLJG2174	161296	LP873SDT	5HZBF1929HLEH2158	171303
MC873SDT	5HZBF1921GLKG2178	161331	LP873SDT	5HZBF192XHHLGH2188	171315

AFFECTED MACHINES – VVK01-0002

MODEL	VIN	SERIAL/UNIT	MODEL	VIN	SERIAL/UNIT
LP873SDT	5HZBF1921HLGH2189	171323	LP873XDT	5HZBF1923HLLH2232	181218
LP873SDT	5HZBF1923HLHH2195	171340	LP873SDT	5HZBF1927JLEJ2163	181233
LP873SDT	5HZBF1925HLHH2196	171341	MC873SDT	5HZBF192XJLAJ2100	181247
LP873SDT	5HZBF1922HLJH2202	171352	LP873SDT	5HZBF1920JLEJ2179	181249
LP873SDT	5HZBF1927HLHH2197	171363	LP873SDT	5HZBF1929JLDJ2159	181253
LP873SDT	5HZBF1929HLHH2198	171364	LP873SDT	5HZBF1922JLEJ2202	181257
MC873SDT	5HZBF1927HLCH2136	171423	MC873SDT	5HZBF1929JLEJ2214	181259
MC873SDT	5HZBF1928HLJH2205	171423	LP873SDT	5HZBF1924JLEJ2203	181279
LP873SDT	5HZBF192XHLJH2206	171424	LP873SDT	5HZBF1926JLEJ2204	181282
LP873XDT	5HZBF1921HLKH2212	171438	LP873SDT	5HZBF1926JLEJ2171	181283
LP873SGT	5HZBF1923HLJH2208	171442	LP873SDT	5HZBF1928JLEJ2172	181291
LP873SDT	5HZBF1924HLKH2222	171490	LP873SDT	5HZBF1922JLEJ2166	181293
LP873SDT	5HZBF1929HLKH2216	171495	LP873SDT	5HZBF1929JLEJ2200	181294
LP873SDT	5HZBF1922HLKH2218	171499	LP873SDT	5HZBF192XJLEJ2173	181295
LP873SDT	5HZBF1924HLKH2219	171503	LP873SGT	5HZBF1928HLGH2173	181295
LP873SDT	5HZBF1923HLLH2229	171528	LP873SDT	5HZBF1921JLEJ2174	181296
LP873SDT	5HZBF192XHLLH2230	171529	LP873SDT	5HZBF1926JLEJ2168	181298
LP873SDT	5HZBF1922HLLH2237	171556	LP873SDT	5HZBF1928JLEJ2169	181299
LP873SDT	5HZBF1920HLMH2238	171559	LP873SDT	5HZBF1923JLEJ2175	181302
LP873SDT	5HZBF1922HLMH2239	171569	LP873SDT	5HZBF1925JLEJ2176	181303
			LP873SDT	5HZBF1927JLEJ2177	181310
LP873SDT	5HZBF1922JLAJ2107	181043	LP873SDT	5HZBF1927JLEJ2180	181311
MC873SDT	5HZBF1922JLBJ2109	181049	LP873SDT	5HZBF1929JLEJ2181	181312
LP873SDT	5HZBF1921JLBJ2117	181058	LP873SDT	5HZBF1920JLEJ2182	181313
LP873SDT	5HZBF1923JLBJ2118	181059	LP873SDT	5HZBF1922JLEJ2183	181314
LP873SDT	5HZBF1920JLBJ2111	181063	LP873SDT	5HZBF1928JLEJ2186	181323
LP873SDT	5HZBF1922JLBJ2112	181064	LP873SDT	5HZBF192XJLEJ2187	181324
MC873SDT	5HZBF192XJLBJ2116	181074	LP873SDT	5HZBF1921JLEJ2188	181325
MC873SDT	5HZBF1923HLHH2200	181092	LP873SDT	5HZBF1927JLEJ2194	181334
LP873SDT	5HZBF1927JLBJ2123	181094	LP873SDT	5HZBF1923JLEJ2211	181377
LP873SDT	5HZBF1929JLDJ2162	181109	LP873SDT	5HZBF1924JLEJ2198	181380
LP873SDT	5HZBF1928JLCJ2134	181138	LP873SDT	5HZBF1925JLGJ2247	181385
LP873SDT	5HZBF1927JLDJ2158	181173	LP873SDT	5HZBF1923JLGJ2246	181386
MC873SDT	5HZBF1928JLCJ2148	181185	MC873SDT	5HZBF1920JLCJ2144	181387
LP873SDT	5HZBF1928JLCJ2151	181191	LP873SDT	5HZBF1925JLEJ2212	181395
LP873SDT	5HZBF192XJLCJ2152	181194	LP873SDT	5HZBF1929JLFJ2216	181400
LP873SDT	5HZBF1921JLCJ2153	181195	LP873SDT	5HZBF1920JLFJ2217	181401
LP873SDT	5HZBF1929JLEJ2178	181206	LP873SDT	5HZBF1927JLFJ2215	181436
LP873SDT	5HZBF1925JLDJ2160	181217	LP873SDT	5HZBF192XJLGJ2230	181437

AFFECTED MACHINES – VVK01-0002

MODEL	VIN	SERIAL/UNIT	MODEL	VIN	SERIAL/UNIT
LP873SDT	5HZBF1921JLGJ2231	181438	LP873SDT	5HZBF192XJLMJ2378	181644
LP873SDT	5HZBF1927JLGJ2248	181453	LP873SDT	5HZBF1925JLKJ2346	181652
MC873SDT	5HZBF1923JLGJ2232	181474	LP873SDT	5HZBF1921JLJJ2292	181655
LP873SDT	5HZBF1925JLHJ2283	181475	LP873SDT	5HZBF1923JLJJ2293	181656
LP873SDT	5HZBF1925JLGJ2233	181477	LP873SDT	5HZBF1927JLKJ2316	181657
LP873SDT	5HZBF1927JLGJ2234	181478	MC873SDT	5HZBF1925JLKJ2315	181658
LP873SDT	5HZBF192XJLHJ2263	181479	LP873SDT	5HZBF1927JLKJ2347	181671
LP873SDT	5HZBF1920JLGJ2236	181480	LP873SDT	5HZBF1921JLKJ2330	181672
LP873SDT	5HZBF1922JLGJ2237	181481	LP873SDT	5HZBF1923JLKJ2331	181673
LP873SDT	5HZBF1924JLGJ2238	181482	LP873SDT	5HZBF1925JLKJ2332	181674
LP873SDT	5HZBF1926JLGJ2239	181483	LP873SDT	5HZBF1927JLKJ2333	181675
LP873SDT	5HZBF1922JLGJ2240	181484	LP873SDT	5HZBF1924KLBK2142	191001
LP873SDT	5HZBF1924JLGJ2241	181485	LP873SDT	5HZBF1925KLLJ2352	191022
LP873SDT	5HZBF1926JLGJ2242	181487	LP873SDT	5HZBF1929KLLJ2354	191031
LP873SDT	5HZBF1928JLGJ2243	181488	LP873SDT	5HZBF1920KLLJ2355	191032
LP873SDT	5HZBF192XJLGJ2244	181489	LP873SDT	5HZBF1928KLLJ2362	191051
LP873SDT	5HZBF1921JLGJ2245	181490	LP873SDT	5HZBF192XKLLJ2363	191062
MC873SDT	5HZBF1927JLHJ2267	181499	LP873SDT	5HZBF1925KLAK2129	191077
LP873SDT	5HZBF1927JLHJ2284	181506	LP873SDT	5HZBF1921KLAK2130	191078
LP873SDT	5HZBF1929JLHJ2285	181507	LP873SDT	5HZBF1923KLAK2131	191079
LP873SDT	5HZBF192XJLHJ2280	181508	LP873SDT	5HZBF1927KLLJ2334	191080
LP873SDT	5HZBF1921JLHJ2281	181509	LP873SDT	5HZBF1929KLLJ2335	191081
MC873SDT	5HZBF1923JLHJ2282	181514	LP873SDT	5HZBF1920KLLJ2336	191082
LP873SDT	5HZBF1920JLHJ2269	181527	LP873SDT	5HZBF192XKLAK2109	191126
LP873SDT	5HZBF1928JLHJ2262	181528	LP873SDT	5HZBF1923KLLJ2329	191132
MC873SDT	5HZBF1928JLHJ2259	181550	LP873SDT	5HZBF1922KLLJ2337	191135
LP873SDT	5HZBF1927JLJJ2295	181552	LP873SDT	5HZBF1924KLLJ2338	191140
LP873SDT	5HZBF1920JLJJ2302	181560	LP873SDT	5HZBF1925KLAK2101	191145
LP873SDT	5HZBF1922JLJJ2303	181562	LPSDT	5HZG19212KK002041	191150
LP873SDT	5HZBF1923JLJJ2309	181579	LPSDT	5HZG19214KK002042	191151
LP873SDT	5HZBF192XJLJJ2310	181580	LP873SDT	5HZBF1922KLAK2136	191156
LP873SDT	5HZBF1921JLJJ2311	181581	LP873SDT	5HZBF1928KLMJ2364	191157
LP873SDT	5HZBF1923JLJJ2312	181582	LP873SDT	5HZBF1926KLMJ2380	191158
LP873SDT	5HZBF1928JLJJ2306	181585	LP873SDT	5HZBF1928KLAK2139	191211
LP873SDT	5HZBF1924JLKJ2323	181586	LPSDT	5HZG26215KK002076	191279
LP873SDT	5HZBF1926JLKJ2324	181587	LPSDT	5HZG19212KK002024	191297
LP873SDT	5HZBF1928JLKJ2325	181595	LPSGT	5HZH19224KK002006	191307
LP873SDT	5HZBF192XJLKJ2326	181596	LPSGT	5HZH19226KK002007	191308
LP873SGT	5HZBF1924JLJF2219	181630	LPSGT	5HZH19228KK002008	191309

AFFECTED MACHINES – VVK01-0002

MODEL	VIN	SERIAL/UNIT
LPSGT	5HZH1922XKK002009	191310
LPSGT	5HZH19226KK002010	191335
LPSDT	5HZG1921XKK002031	191341
LPSDT	5HZG19211KK002032	191342
LPSDT	5HZG19219KK002036	191346
LPSDT	5HZG19210KK002068	191381
LPSDT	5HZG19212KK002069	191382
LPSDT	5HZG19219KK002070	191383
LPSDT	5HZG19210KK002071	191384
LPSDT	5HZG19217KK002049	191391
LPSGT	5HZH19225KK002015	191392
LPSDT	5HZG19212KK002055	191399
LPXDT	5HZJ19234KK002016	191402
LPXDT	5HZJ19236KK002017	191403
LPSDT	5HZG19216KK002057	191404
LPSDT	5HZG19218KK002058	191405
LPXDT	5HZJ19231KK002023	191426
LPXDT	5HZJ16238KK002034	191463
MINICOMBO	5HZK19247KK002010	191560
MINICOMBO	5HZK19240KK002009	191603
LPSGT	5HZH19223LK002032	191679
LPXDT	5HZJ16232LK002080	191714
LPXDT	5HZJ16236LK002082	191724
LPXDT	5HZJ1623XLK002084	191736
LP873XDT	5HZJ1923XLK002085	191764
LP873XDT	5HZJ19235LK002088	191765

Figure 1

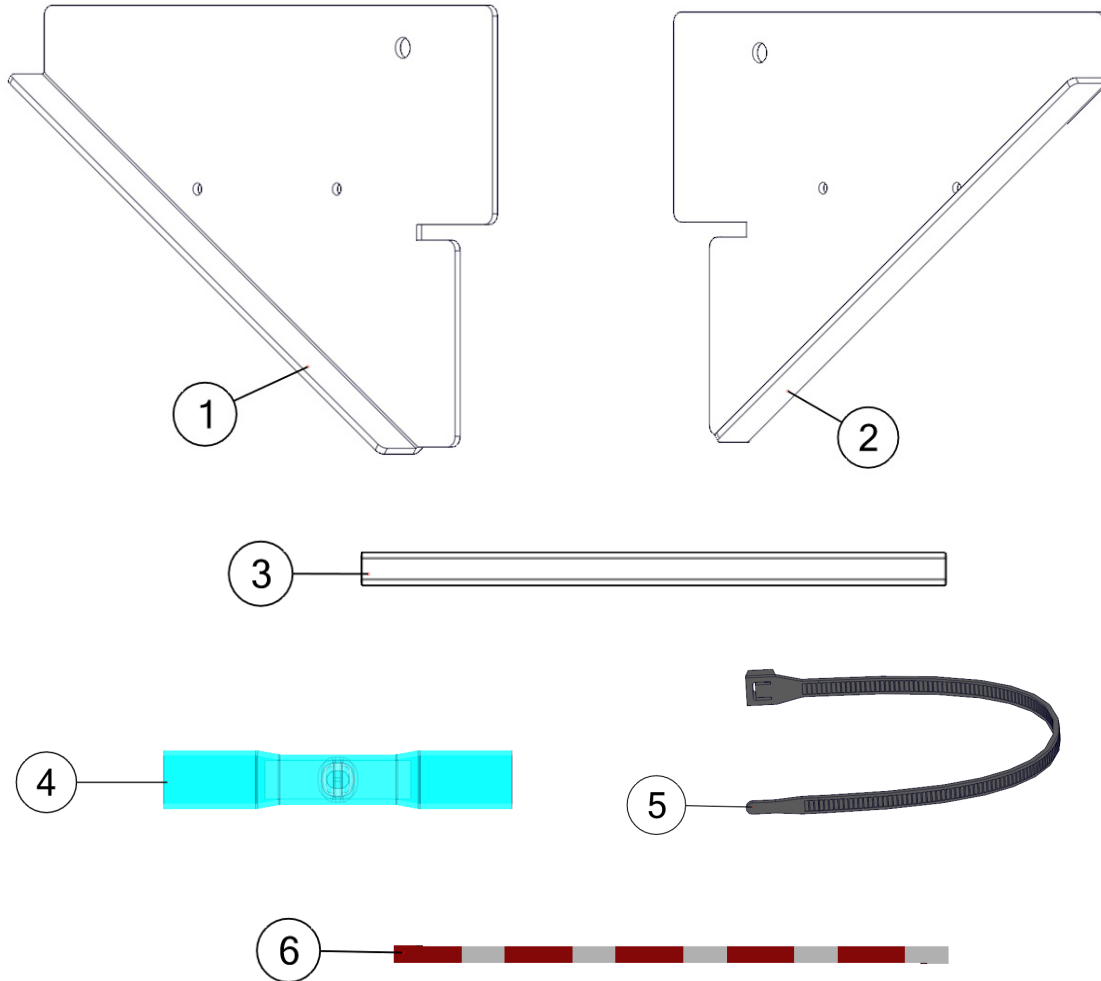

FIGURE 1 Parts List			
REF. NO.	PART NO.	DESCRIPTION	QTY.
1	B250-4031	HEAVY FENDER GUSSET, RS	2
2	B250-4032	HEAVY FENDER GUSSET, CS	2
3	S300-0316-0B	3" SCISSOR TUBE	1
4	P-2369	16-14 HEAT SEAL BUTT CONNECTOR, BLUE	18
5	P-1301	ZIP TIE	10
6	P-0485	2" (2.5 cm) WIDE, 101" (256.5 cm) LONG CONSPICUITY TAPE	2