



SIM 32 01 19

2020-01-08

RECALL CAMPAIGN 19V-601: STEERING GEAR TIE ROD

Please perform the procedure outlined in this Service Information on all affected vehicles before customer delivery. In the event the customer has already taken delivery of the vehicle, please perform the procedure the next time the vehicle is in the shop.

This Service Information Bulletin (Revision 2) replaces SI M32 01 19 **dated September 2019**.

What's New (Specific text highlighted):

- Parts information- Part number changed to alphanumeric

MODEL

E-Series	Model Description	Production Date
F57	MINI Convertible	March 18, 2019
F60	MINI Countryman	March 15, 2019 thru April 8, 2019

AFFECTED VEHICLES

Vehicles which require this Recall Campaign to be completed will show it as "Open" when checked either in AIR, the "Service Menu" of DCSnet (Dealer Communication System) or with ISPA NEXT. Recall letter and Q&A are attached.

SITUATION

BMW of North America, LLC is conducting a Voluntary Safety Recall (effective August 8, 2019) on a small number of Model Year 2019 MINI vehicles that were produced between March 15, 2019 and April 8, 2019. The cone collar disc may not have been installed on the tie rod.

CAUSE

During the manufacturing process, a cone collar disc on the tie rod may not have been installed.

CORRECTION

Check both tie rods, and replace one or both if necessary.

PROCEDURE

1. Remove both front wheels.

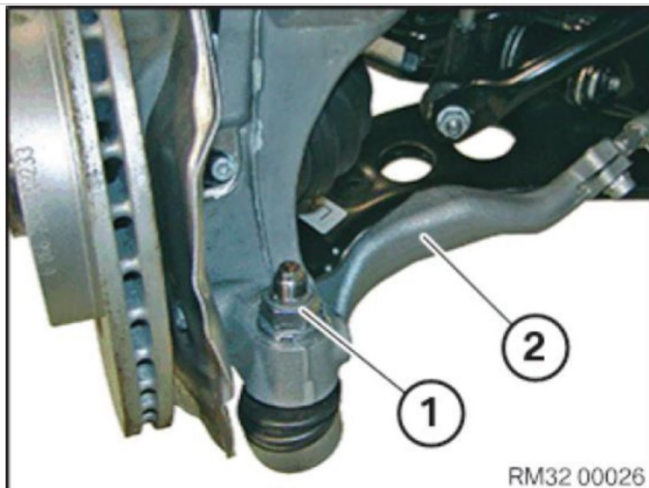

2. Remove and discard the tie rod nut (1) on left and right swivel bearing.

- Release the tie rods (2) from the swivel bearings

Examples:



Cone collar disc installed: no knurling visible on the shank.



Cone collar disc not installed: knurling visible on the shank (arrow).

3. Inspect both tie rods for the presence of the cone collar disc.
4. Is the cone collar disc installed?
 - Yes = No further action required. Reinstall the tie rods as per repair manual **RA 32 21 151** and properly torque the **new** M14 nuts
 - No = Proceed to next step
5. Replace the tie rod and swivel bearing as per the repair manual **RA 32 21 151** and **RA 31 21 090**.
6. Perform a wheel alignment procedure.

PARTS INFORMATION

Obtain and confirm the part numbers for your specific vehicle by entering the chassis number in either ETK or AIR which takes into account specific equipment and/or options.

Part Number	Description	Quantity
All		
33 30 6 787 062	Combination nut (M14x1,5-10ZNNIV)	2
When required		
	F60	
32 10 5A018D0	Ball joint left	1
32 10 5A018D4	Ball joint right	1
Or	F57	
32 10 6 854 734	Ball joint left	1
32 10 6 854 737	Ball joint right	1
32 10 6 765 080	Clamping bolt (M10X1X22-10.9)	2
33 40 6 858 534	Collar bolt with compression spring (M16x1,5x60-8.8)	1
31 20 6 872 920	Spherical collar screw (M12x1.25x45)	4
07 11 9 905 032	Hex nut (M10-10-ZNS3)	1
31 30 6 798 530	Hexagon screw with flange (M10x85 8.8 ZNS3)	1
33 30 6 760 587	Hex nut with flange (M10-10 ZNS3)	1
31 10 6 876 027	ASA-Bolt (M10x55)	1
	F60	
31 21 6 876 645	Carrier, left	1
31 21 6 876 646	Carrier, right	1
Or	F57	
31 21 6 876 643	Carrier, left	1
31 21 6 876 644	Carrier, right	1

Note: Additional hardware may be required to perform chassis alignment.

WARRANTY INFORMATION

Reimbursement for this Recall will be via normal claim entry utilizing the following information:

Defect Code:	0032900200
---------------------	-------------------

Completion “before” the first vehicle delivery to a customer or the vehicle is already in the workshop-

Work Pkg	Labor Operation:	Labor Allowance:	Description (Plus work):
# 1	00 68 602	4 FRU	Check both tie rods (No repair is necessary).
Or:			
# 2	00 68 603	27 FRU	Check both tie rods and replace one side (tie rod and swivel bearing) includes wheel alignment check KDS with ride-height measurement without load, adjusting toe-in.
Or:			
# 3	00 68 604	37 FRU	Check both tie rods and replace both sides (tie rod and swivel bearing) includes wheel alignment

		check KDS with ride-height measurement without load, adjusting toe-in.
--	--	--

Or:

The vehicle arrives at your center and this Recall Campaign shows open (No other Main work will be performed/claimed during this workshop visit)-

Work Pkg	Labor Operation:	Labor Allowance:	Description (Main work):
# 4	00 68 077	6 FRU	Check both tie rods (No repair is necessary).
Or:			
# 5	00 68 078	28 FRU	Check both tie rods and replace one side (tie rod and swivel bearing) includes wheel alignment check KDS with ride-height measurement without load, adjusting toe-in.
Or:			
# 6	00 68 079	38 FRU	Check both tie rods and replace both sides (tie rod and swivel bearing) includes wheel alignment check KDS with ride-height measurement without load, adjusting toe-in.

And, as necessary, with:

Work Package #2, #3, #5 and #6-

Labor Operation:	Labor Allowance:	Description (Associated work):
00 68 606	10 FRU	Additional work if necessary / Adjust rear axle with eccentric screws.

Claim Repair Comments

Unless additional related/in conjunction work was required (not addressed and/or included in one of the options provided above), then only reference the SIB number and the work package (Pkg) number performed in the RO technician notes and in the claim comments (For example: M32 01 19 WP 1), unless otherwise required by State law.

And, as applicable:

Alternative Mobility Solution (AMS) for Vehicle Owners (RO and Claim Comments Required)

This Recall repair qualifies for Alternative Mobility Solution (AMS) expense reimbursement, claim this item under the Defect Code noted above as follows:

Sublet Code 2 - Itemize the AMS sublet amount on the repair order and in the claim comment section.

Please refer to SI M01 01 17 for additional information.

Supporting Materials

[picture_as_pdf M320119 Recall Notice.pdf](#)

[picture_as_pdf M320119 Attachment2019-Fxx-TieRod-QA-\(8Aug2019\)_Final.pdf](#)

SAFETY RECALL NOTICE

To: All Center Operators, Sales Managers, Service Manager, Parts Manager and Warranty Processor

RE: Recall 19V-601: Steering Gear Tie Rod – M32 01 19

BMW of North America, LLC is conducting a Voluntary Safety Recall (effective August 8, 2019) on a small number of Model Year 2019 MINI vehicles that were produced between March 15, 2019 and April 8, 2019.

Please be reminded that it is a violation of federal law (The Safety Act) for you to sell, lease or deliver any new motor vehicle covered by this notification until the recall repair has been performed. This means that centers may not legally deliver new motor vehicles to consumers until they are fixed or use/sell replacement equipment/parts subject to this recall. Note also that substantial civil penalties apply to violations of the Safety Act.

Also, you should not sell, lease or deliver any Certified Pre-Owned or used vehicles subject to a safety recall until the repair is completed.

Please follow any special instructions that we provide to you for the return or disposition of recall parts.

We appreciate all your assistance with this Recall.

**Steering Gear Tie Rod
Safety Recall 19V-601
Model Year 2018-2019
BMW X1 / X2
MINI Convertible / Countryman
Last Updated 08/21/2019**

- Q1. Which BMW Group models in the US are potentially affected by this Safety Recall?**
Approximately 20 Model Year 2018-2019 BMW X1 and X2, and 12 Model Year 2019 MINI Cooper Convertible and Countryman vehicles, are potentially affected.
- Q2. What is the specific issue?**
The steering gear tie rod may not have been produced to supplier specifications.
- Q3. What can happen as a result of this issue?**
Over time, the tie rod could become damaged and eventually break, affecting vehicle handling and control, and increasing the risk of a crash.
- Q4. Why are other BMW Group vehicles not included in this Safety Recall?**
The steering gear tie rod was produced to supplier specifications.
- Q5. How did BMW Group become aware of this issue?**
BMW Group became aware of this issue through its quality control procedures.
- Q6. Can I determine if this issue exists in my vehicle?**
If you feel unusual vibration from the steering wheel, or have difficulty controlling the vehicle, it may be experiencing this issue.
- Q7. What should I do if I notice this condition in my vehicle?** 
If this condition occurs, carefully move away from traffic and pull over to a safe location as soon as possible. All occupants should carefully exit the vehicle and move to a safe location away from traffic. Do not continue to drive the vehicle. **Contact BMW Roadside Assistance at 1-800-332-4269, or MINI Roadside Assistance at 1-866-646-4772, immediately to have your vehicle brought to the nearest authorized BMW center or MINI dealer.** If you are not the only driver of this vehicle, please advise all other drivers and passengers of this important information.
- Q8. Can I continue to drive my vehicle (before I receive my letter)?**
Yes. However, when you receive a letter requesting you to make an appointment to have this Safety Recall performed by an authorized BMW center or MINI dealer, please do so as soon as possible.
- Q9. How will my vehicle be repaired?**
The steering gear tie rod will be inspected and, if necessary, replaced. This will be performed for free and may take several hours.
- Q10. Is BMW Group aware of any accidents or injuries in the US, involving these BMW Group vehicles associated with this Safety Recall?**
No.
- Q11. How will I be informed of this Safety Recall?**
You will receive a letter in October via First Class mail advising you of this Safety Recall and requesting you to schedule an appointment with an authorized BMW center or MINI dealer to have this Safety Recall performed. You can locate your nearest authorized BMW center at www.bmwusa.com/dealer, and your nearest authorized MINI dealer at www.miniusa.com/dealer.

To ensure the BMW Group has your most recent contact and vehicle information, please register your BMW vehicle at www.bmwusa.com/myBMW, or your MINI vehicle at www.miniusa.com/ol. Registration is free, and will give you access to factory initiated campaigns and other information specific to your vehicle.

**Steering Gear Tie Rod
Safety Recall 19V-xxx
Model Year 2018-2019
BMW X1 / X2
MINI Convertible / Countryman
*Last Updated 08/08/2019***

Q12. Do I have to wait for my letter to have my vehicle serviced?

Yes. We are in the process of implementing this Safety Recall to ensure that the necessary tools, parts, and procedures are available prior to contacting you to schedule an appointment with your authorized BMW center or MINI dealer to have this Safety Recall performed. For the latest updates to this Safety Recall, please visit www.bmwusa.com/recall, or www.miniusa.com/recall.