

**TECHNICAL INSTRUCTIONS**

**FOR**

**SAFETY (NONCOMPLIANCE) RECALL K0N**

**BACKUP CAMERA DISPLAY MAY NOT OPERATE**

**CERTAIN 2019 MODEL YEAR RAV4 / RAV4 HV**

The repair quality of covered vehicles is extremely important to Toyota. All dealership technicians performing this recall are required to successfully complete the most current version of the E-Learning course “Safety Recall and Service Campaign Essentials”. To ensure that all vehicles have the repair performed correctly; technicians performing this recall repair are required to currently hold at least one of the following certification levels:

- Certified Technician (any specialty)
- Expert Technician (any specialty)
- Master Technician
- Master Diagnostic Technician

It is the dealership’s responsibility to select technicians with the above certification level or greater to perform this recall repair. Carefully review your resources, the technician skill level, and ability before assigning technicians to this repair. It is important to consider technician days off and vacation schedules to ensure there are properly trained technicians available to perform this repair at all times.

## I. OPERATION FLOW CHART

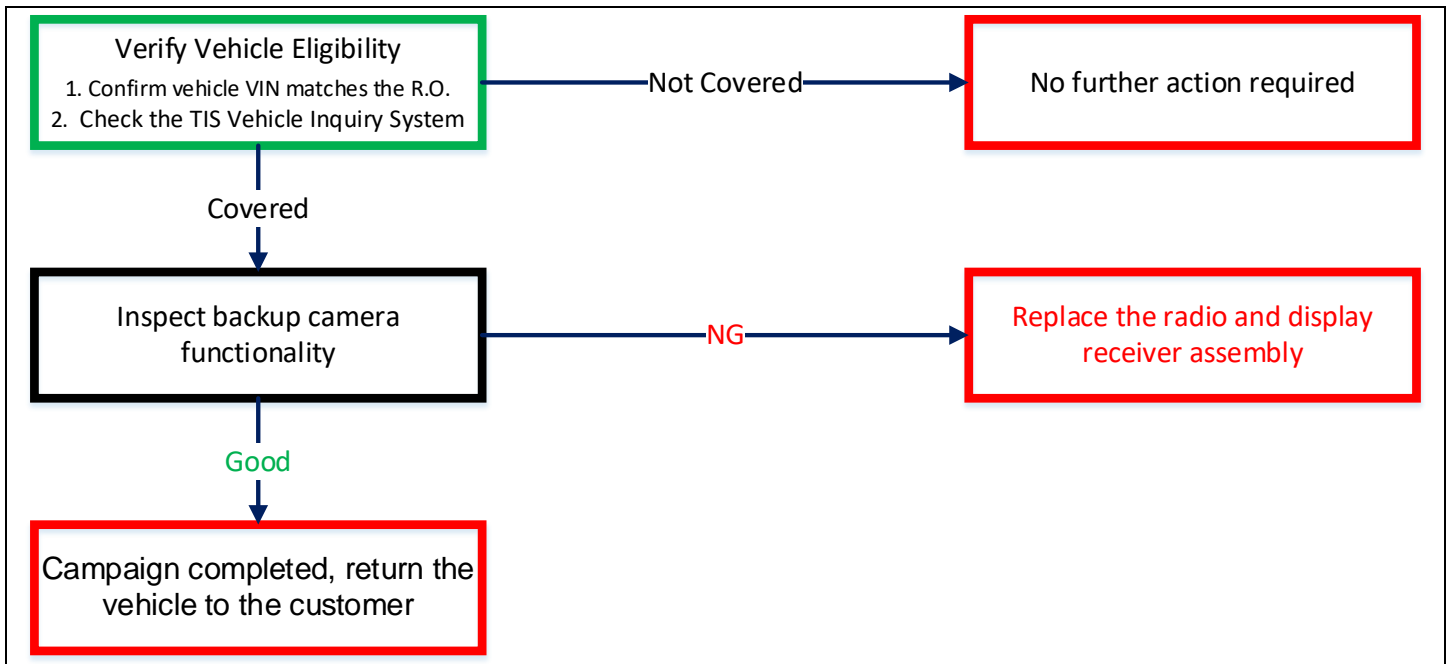

## II. IDENTIFICATION OF AFFECTED VEHICLES

- Compare the vehicle VIN to the VIN listed on the Repair Order to ensure they match
- Check the TIS Vehicle Inquiry System to confirm the VIN is involved in this Safety (Noncompliance) Recall, and that it has not already been completed prior to dealer shipment or by another dealer.
- TMNA warranty will not reimburse dealers for repairs completed on vehicles that are not affected or were completed by another dealer.

## III. PREPARATION

### A. PARTS

| Part Number | Part Description                                       | Quantity |
|-------------|--|----------|
| 86140-0R320 | Radio and Display Receiver Assembly (USA Vehicles)*    | 1        |
| 86140-0R230 | Radio and Display Receiver Assembly (Canada Vehicles)* | 1        |

\*Both retailed and in -stock vehicles require new unit replacement. Do NOT obtain through the Manufacture Exchange Center

### B. TOOLS & EQUIPMENT

- Techstream
- Moulding Remover B
- Standard Hand Tools
- Torque Wrench

### C. MATERIALS

- Marker Pen

## IV. BACKGROUND

The involved vehicles are equipped with a back-up camera system which activates to show the area behind the vehicle when the vehicle is shifted into reverse. In these vehicles, there is a possibility that a damaged connector in the audio unit display is causing the back-up camera system not to activate. If the driver reverses the vehicle without checking his/her surroundings when the vehicle has this condition, there can be an increased risk of a crash. Also, this condition would lead to a noncompliance with certain safety regulations.

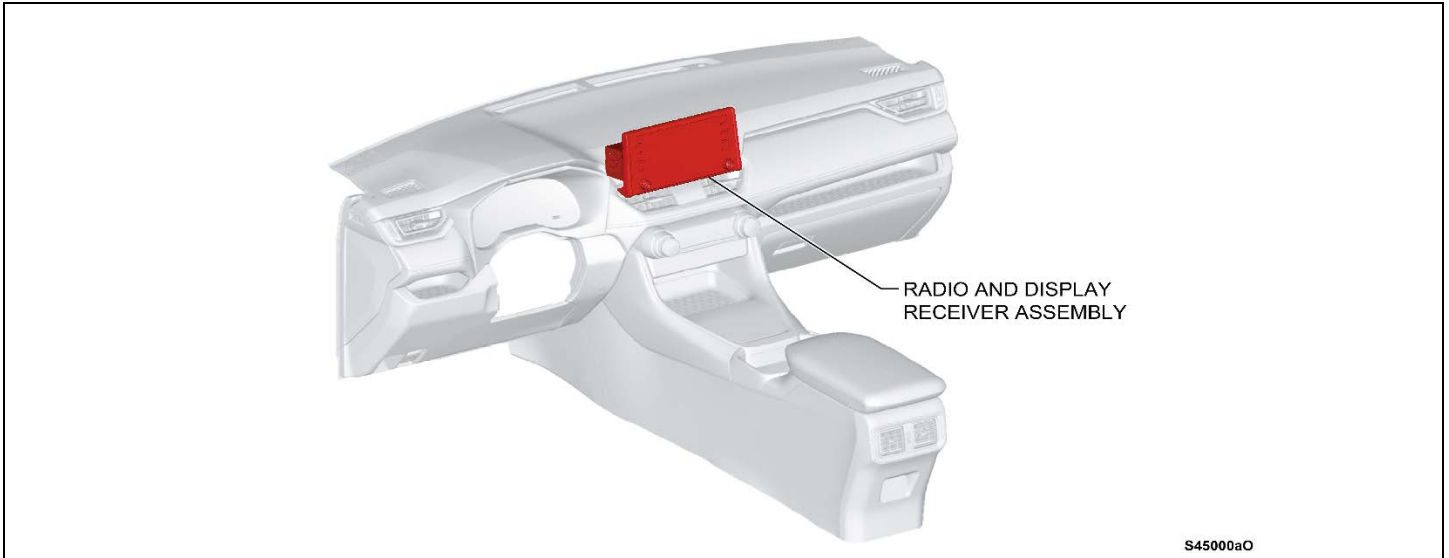



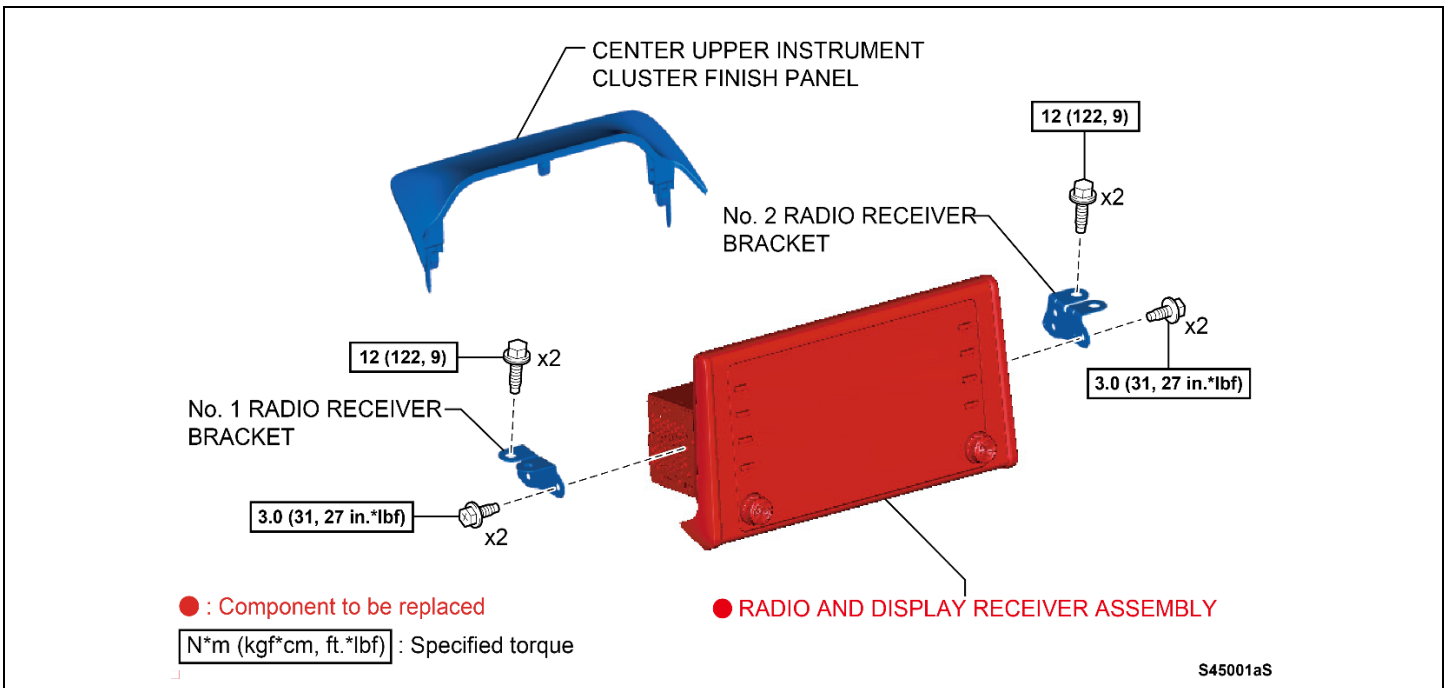

## V. WORK PROCEDURE

### A. COMPONENTS



**B. INSPECTION**

| INSPECTION METHOD  |  |                               |
|--|--|-------------------------------|
| <p><b>1. INSPECT BACKUP MONITORING SYSTEM FUNCTION</b></p> <p>a. Turn the IG ON<br/>b. Shift the vehicle into Reverse</p>  |  | <p><b>ACTIONS TO TAKE</b></p> |
| <p><b>OK</b> Backup camera is functional</p> <div style="display: flex; align-items: center;">  <div style="margin: 0 20px; font-size: 2em;">➔</div>  </div> <p>*Home screen is used as an example.</p> | <p>No further action required.<br/>Campaign Complete</p>   |                               |
| <p><b>NG</b> No response</p> <div style="display: flex; align-items: center;">  <div style="margin: 0 20px; font-size: 2em;">➔</div>  </div> <p>*Home screen is used as an example.</p>               | <p>Radio and Display Receiver Assembly replacement required</p> <p>Proceed to the next page for instructions on how to replace the Radio and Display Receiver Assembly</p> |                               |

## C. REPLACE RADIO AND DISPLAY RECEIVER ASSEMBLY

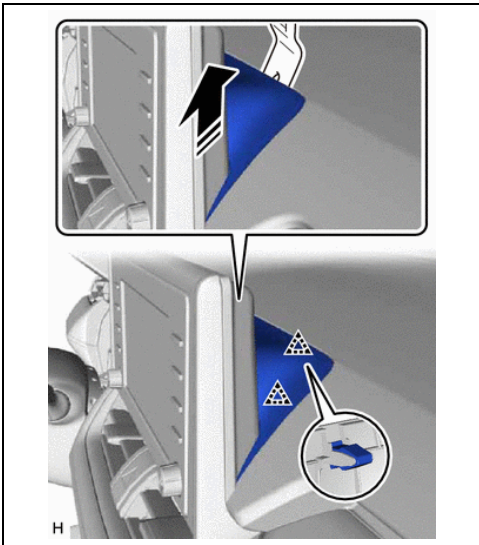

### 1. REMOVE CENTER UPPER INSTRUMENT CLUSTER FINISH PANEL

- a. Ensure the IG is OFF
- b. Using moulding remover B, detach the clips

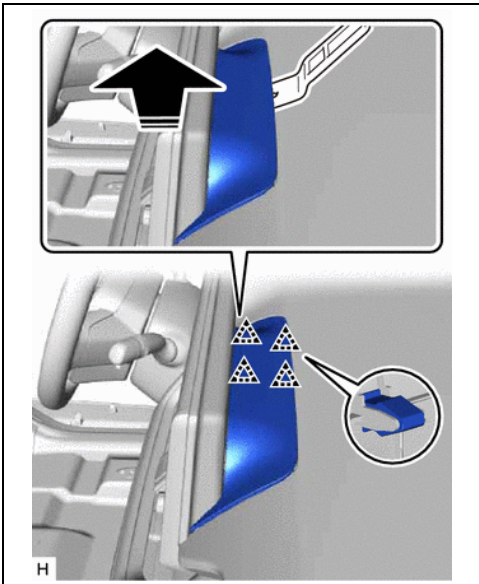

- c. Using moulding remover B, detach the clip as shown in the illustration and remove the instrument cluster finish panel

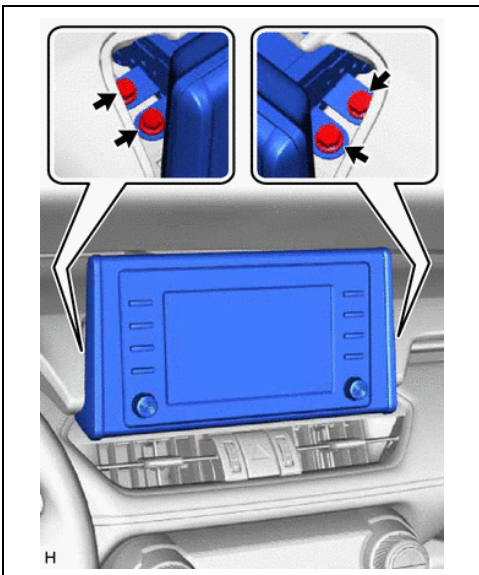

### 2. REMOVE THE RADIO AND DISPLAY RECEIVER ASSEMBLY WITH BRACKET

- a. Remove the 4 bolts

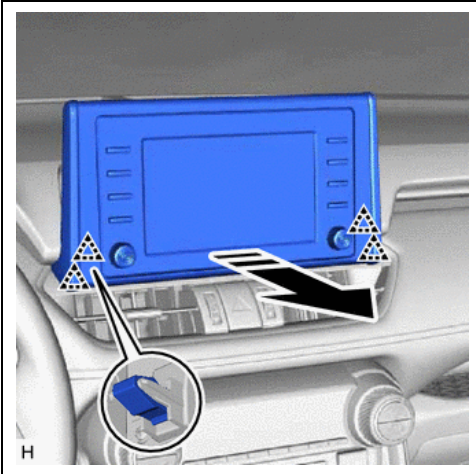

- b. Detach the clip and remove the radio and display receiver assembly with bracket
- c. Disconnect each connector

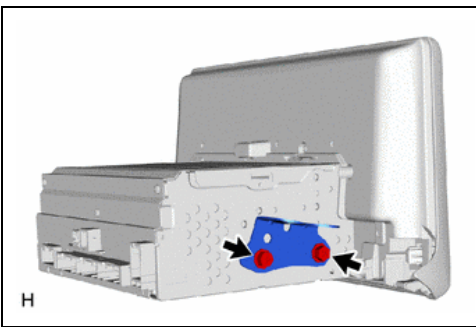

- d. Remove the 2 screws and No.1 radio receiver bracket

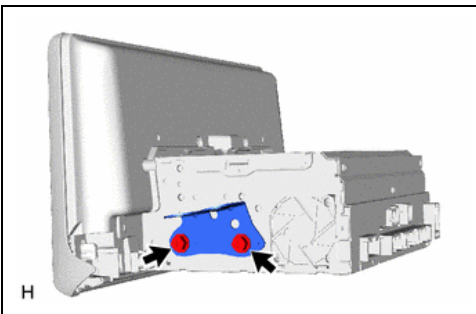

- e. Remove the 2 screws and No.2 radio receiver bracket

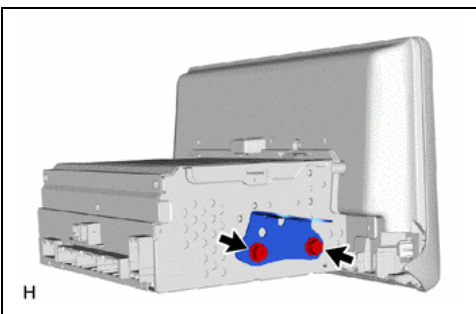

3. **INSTALL THE *NEW* RADIO AND DISPLAY RECEIVER ASSEMBLY WITH BRACKET**
- a. Install the No.1 radio receiver bracket with the 2 screws

**Torque: 27 in.lbf (3 Nm, 31 kgf-cm)**

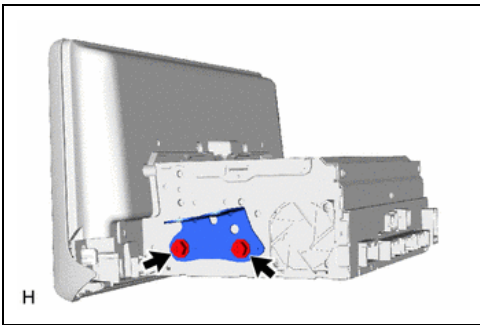

- b. Install the No.2 radio receiver bracket with the 2 screws  
**Torque: 27 in.lbf (3 Nm, 31 kgf-cm)**

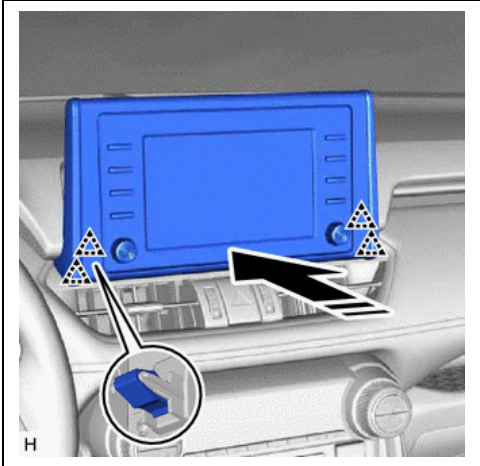

- c. Connect each connector
- d. Attach the clip to install the **NEW** radio and display receiver assembly with bracket

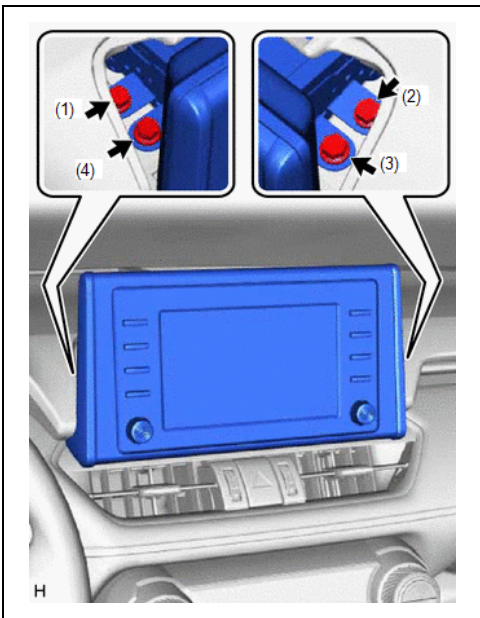

- e. Install the 4 bolts in the order shown in the illustration  
**Torque: 9 ft.lbf (12 Nm, 122 kgf-cm)**

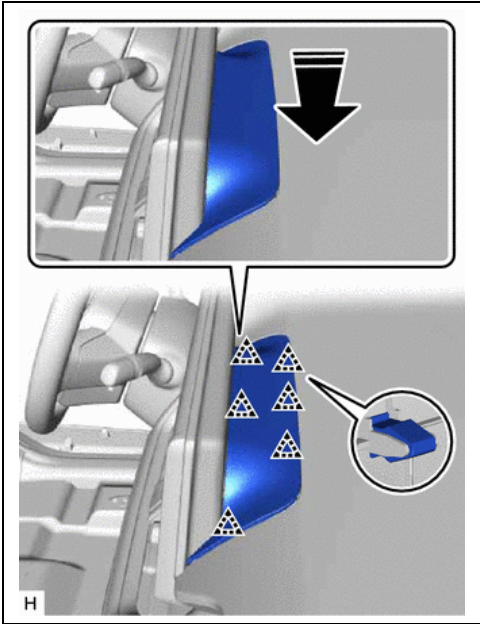

**4. INSTALL THE CENTER UPPER INSTRUMENT CLUSTER FINISH PANEL**

- a. Attach the clip to install the center upper instrument cluster finish panel
- b. **Unless the part has a core charge and needs to be returned for reimbursement or requested for parts recovery return**

◀ VERIFY REPAIR QUALITY ▶

- Confirm the backup camera is functional

If you have any questions regarding this recall, please contact your regional representative.

**VI. APPENDIX**

**A. PARTS DISPOSAL**

As required by Federal Regulations, please make sure all recalled parts (original parts) removed from the vehicle are disposed of in a manner in which they will not be reused, **Unless the part has a core charge and needs to be returned for reimbursement or requested for parts recovery return**

**B. CAMPAIGN DESIGNATION DECORDER**

