

June 2019
FL816A-F
NHTSA #19V-367 (Non-School Bus)
NHTSA #19V-368 (School Bus)
Transport Canada #2019-227 (Non-School Bus)

Subject: Brake Caliper Mounting Bolts

Models Affected: Specific Freightliner 108SD, 114SD, Argosy, Business Class M2, Cascadia, and Columbia vehicles; Western Star 5700 vehicles; Freightliner Custom Chassis B2 school bus chassis (Thomas Built Buses Saf-T-Liner C2) and X-Line chassis manufactured August 20, 2018, through September 29, 2018, and equipped with air disc brakes.

General Information

Daimler Trucks North America LLC (DTNA), on behalf of its Freightliner Trucks Division and wholly owned subsidiaries, Western Star Truck Sales, Inc., and Freightliner Custom Chassis Corporation, has decided that a defect that relates to motor vehicle safety exists on the vehicles mentioned above.

There are approximately 400 vehicles involved in this campaign.

On certain vehicles, insufficiently torqued caliper mounting bolts may not provide adequate clamping force between the brake caliper and brake anchor plate, potentially resulting in reduced brake effectiveness, which could increase the risk of a crash.

Caliper mounting bolts will be inspected and replaced as needed.

Additional Repairs

Dealers must complete all outstanding Recall and Field Service campaigns prior to the sale or delivery of a vehicle. A Dealer will be liable for any progressive damage that results from its failure to complete campaigns before sale or delivery of a vehicle.

Owners may be liable for any progressive damage that results from failure to complete campaigns within a reasonable time after receiving notification.

Work Instructions

Please refer to the attached work instructions. Prior to performing the campaign, check the vehicle for a completion sticker (Form WAR260).

Replacement Parts

Replacement parts are now available and can be obtained by ordering the part number(s) listed below from your facing Parts Distribution Center. **Letter groups include both front and rear axles and different caliper types, as noted for each group in the table below.**

If our records show your dealership has ordered any vehicles involved in campaign number FL816, a list of the customers and vehicle identification numbers will be available in OWL. Please refer to this list when ordering parts for this recall.

June 2019
 FL816A-F
 NHTSA #19V-367 (Non-School Bus)
 NHTSA #19V-368 (School Bus)
 Transport Canada #2019-227 (Non-School Bus)

Table 1 - Replacement Parts for FL816A-F

Campaign Number	Vehicle Type	Part Number	Part Description	Qty. per Caliper
FL816A Front & Rear Axle Bendix Axial Caliper	Truck	N210931 020001	SCREW-CAP,HEX,M20X60,10.9,P/O	6 ea
		23-09114-004	WASHER-HRDN,0.81X1.47X.177,ZN	
FL816B Front & Rear Axle Bendix Radial Caliper	School Bus	23-13315-110	SCRW HX,SCKTHD,M16-2X110,12.9	6 ea
FL816C Front & Rear Axle Meritor Axial Caliper	Truck	N210931 020001	SCREW-CAP,HEX,M20X60,10.9,P/O	6 ea
		23-09114-004	WASHER-HRDN,0.81X1.47X.177,ZN	
FL816D Front & Rear Axle Wabco Axial Caliper	Truck	N210931 020001	SCREW-CAP,HEX,M20X60,10.9,P/O	6 ea
		23-09114-004	WASHER-HRDN,0.81X1.47X.177,ZN	
FL816E Rear Axle Bendix Axial Caliper	Motorhome	N210931 020001	SCREW-CAP,HEX,M20X60,10.9,P/O	6 ea
		23-09114-004	WASHER-HRDN,0.81X1.47X.177,ZN	
FL816F Front & Rear Axle Bendix Radial Caliper	Truck	23-13315-110	SCRW HX,SCKTHD,M16-2X110,12.9	6 ea
FL816A-F	All	WAR260	BLANK COMPLETION STICKER	1 ea

Table 1

Removed Parts

U.S. and Canadian Dealers, please follow Warranty Failed Parts Tracking shipping instructions for the disposition of all removed parts. Export distributors, please destroy removed parts unless otherwise advised.

Labor Allowance

Table 3 - Labor Allowance

Campaign Number/Group	Procedure	Time Allowed (hours)	SRT Code	Corrective Action
FL816A-D,F (Bus, Truck)	Inspect caliper bolts, 2 axles	2.0	996-R068A	06-Inspect
FL816A,C,D,F (Truck)	Inspect caliper bolts, second rear axle	1.1	996-R068B	06-Inspect
FL816E (Motorhome)	Inspect caliper bolts, 2 axles, with radial runout check	2.4	996-R068F	06-Inspect
FL816A-D,F (Bus, Truck)	Inspect and torque caliper bolts, 2 axles	2.0	996-R068D	12-Repair Recall/Campaign
FL816A,C,D,F (Truck)	Inspect and torque caliper bolts, second rear axle	1.1	996-R068E	12-Repair Recall/Campaign
FL816E (Motorhome)	Inspect and torque caliper bolts, 2 axles, with radial runout check	2.4	996-R068G	12-Repair Recall/Campaign
FL816A-F (All Vehicles)	Replace caliper bolts, 1 caliper (claim this SRT once for each caliper requiring new bolts, up to 6 times)	0.5	996-R068C	12-Repair Recall/Campaign

Table 2

IMPORTANT: When the Recall has been completed, locate the base completion label in the appropriate location on the vehicle, and attach the red completion sticker provided in the recall kit (Form WAR260). If the vehicle does not have a base completion label, clean a spot on the appropriate location of the vehicle and first attach the base completion label (Form WAR259). If a recall kit is not required or there is no completion sticker in the kit, write the recall number on a blank sticker and attach it to the base completion label.

June 2019

FL816A-F

NHTSA #19V-367 (Non-School Bus)

NHTSA #19V-368 (School Bus)

Transport Canada #2019-227 (Non-School Bus)

Claims for Credit

You will be reimbursed for your parts, labor, and handling (landed cost for Export Distributors) by submitting your claim through the Warranty system within 30 days of completing this campaign. Please reference the following information in OWL:

- Claim type is **Recall Campaign**.
- In the FTL Authorization field, enter the campaign number and appropriate condition code (e.g. **FL816-A, FL816-B, etc.**).
- In the Primary Failed Part Number field, enter **25-FL816-000**.
- In the Parts field, enter the appropriate part number(s) as shown in the Replacement Parts Table.
- In the Labor field, first enter the appropriate SRT from the Labor Allowance Table. Administrative time will be included automatically as SRT 939-6010A for 0.4 hours for RVs or 0.3 hours for all other vehicles. **Some SRTs are optional, and if needed, must be added manually to your claim.**
- The VMRS Component Code is **013-001-129** and the Cause Code is **A1 - Campaign**.
- **U.S. and Canada -- Reimbursement for Prior Repairs.** When a customer asks about reimbursement, please do the following:
 - Accept the documentation of the previous repair.
 - Make a brief check of the customer's paperwork to see if the repair may be eligible for reimbursement. (See the "Copy of Owner Letter" section of this bulletin for reimbursement guidelines.)
 - Submit an OWL Recall Pre-Approval Request for a decision.
 - Include the approved amount on your claim in the Other Charges section.
 - Attach the documentation to the pre-approval request.
 - If approved, submit a based on claim for the pre-approval.
 - Reimburse the customer the appropriate amount.

IMPORTANT: OWL must be viewed prior to performing the recall to ensure the vehicle is involved and the campaign has not been previously completed. Also, check for a completion sticker prior to beginning work.

U.S. and Canadian dealers: Contact the Warranty Campaigns Department via Web inquiry at DTNAConnect.com / WSC, or the Customer Assistance Center at (800) 385-4357, after normal business hours, if you have any questions or need additional information. Export distributors, submit a Web inquiry or contact your International Service Manager.

U.S. and Canadian Dealers: To return excess kit inventory related to this campaign, U.S. dealers must submit a Parts Authorization Return (PAR) to the Memphis PDC. Canadian dealers must submit a PAR to their facing PDC. All kits must be in resalable condition. PAR requests must include the original purchase invoice number. Export Distributors: Excess inventory is not returnable.

The letter notifying U.S. and Canadian vehicle owners is included for your reference.

Please note that the National Traffic and Motor Vehicle Safety Act, as amended (Title 49, United States Code, Chapter 301), requires the owner's vehicle(s) be corrected within a reasonable time after parts are available to you. The Act states that failure to repair a vehicle within 60 days after tender for repair shall be prima facie evidence of an unreasonable time. However, circumstances of a particular situation may reduce the 60 day period. Failure to repair a vehicle within a reasonable time can result in either the obligation to (a) replace the vehicle with an identical or reasonably equivalent vehicle, without charge, or (b) refund the purchase price in full, less a reasonable allowance for depreciation. The Act further prohibits dealers from selling a vehicle unless all outstanding recalls are performed. Any lessor is required to send a copy of the recall notification to the lessee within 10 days. Any subsequent stage manufacturer is required to forward this notice to its distributors and retail outlets within five working days.

June 2019

FL816A-F

NHTSA #19V-367 (Non-School Bus)

NHTSA #19V-368 (School Bus)

Transport Canada #2019-227 (Non-School Bus)

Copy of Notice to Owners

Subject: Brake Caliper Mounting Bolts

For the Notice to U.S. Customers: This notice is sent to you in accordance with the National Traffic and Motor Vehicle Safety Act. **For the Notice to Canadian Customers:** This notice is sent to you in accordance with the Canadian Motor Vehicle Safety Act.

Daimler Trucks North America LLC (DTNA), on behalf of its Freightliner Trucks Division and wholly owned subsidiaries, Western Star Truck Sales, Inc., and Freightliner Custom Chassis Corporation, has decided that a defect that relates to motor vehicle safety exists on specific Freightliner 108SD, 114SD, Argosy, Business Class M2, Cascadia, and Columbia vehicles; Western Star 5700 vehicles; Freightliner Custom Chassis B2 school bus chassis (Thomas Built Buses Saf-T-Liner C2) and X-Line chassis manufactured August 20, 2018, through September 29, 2018, and equipped with air disc brakes.

On certain vehicles, insufficiently torqued caliper mounting bolts may not provide adequate clamping force between the brake caliper and brake anchor plate, potentially resulting in reduced brake effectiveness, which could increase the risk of a crash.

Caliper mounting bolts will be inspected and replaced as needed.

Please contact an authorized Daimler Trucks North America dealer to arrange to have the Recall performed and to ensure that parts are available at the dealership. To locate an authorized dealer, search online at www.Daimler-TrucksNorthAmerica.com. On the menu tab, select "Contact," scroll down to "Find a Dealer," and select the appropriate brand. The Recall may take up to six hours, depending on the work needed, and will be performed at no charge to you.

You may be liable for any progressive damage that results from your failure to complete the Recall within a reasonable time after receiving notification.

If you do not own the vehicle that corresponds to the identification number(s) which appears on the Recall Notification, please return the notification to the Warranty Campaigns Department with any information you can furnish that will assist us in locating the present owner. If you have leased this vehicle, Federal law requires that you forward this notice to the lessee within 10 days. If you are a subsequent stage manufacturer, Federal law requires that you forward this notice to your distributors and retail outlets within five working days. If you have paid to have this recall condition corrected prior to this notice, you may be eligible to receive reimbursement. Please see the reverse side of this notice for details.

For the Notice to U.S. Customers: If you have questions about this Recall, please contact the Warranty Campaigns Department at (800) 547-0712, 7:00 a.m. to 4:00 p.m. Pacific Time, Monday through Friday, e-mail address DTNA.Warranty.Campaigns@Daimler.com, or the Customer Assistance Center at (800) 385-4357 after normal business hours. If you are not able to have the defect remedied without charge and within a reasonable time, you may wish to submit a complaint to the Administrator, National Highway Traffic Safety Administration, 1200 New Jersey Avenue, SE., Washington, DC 20590; or call the Vehicle Safety Hotline at (888) 327-4236 (TTY: 800-424-9153); or to <http://www.safercar.gov>. **For the Notice to Canadian Customers:** If you have questions about this Recall, please contact the Warranty Campaigns Department at (800) 547-0712, 7:00 a.m. to 4:00 p.m. Pacific Time, Monday through Friday, e-mail address DTNA.Warranty.Campaigns@Daimler.com, or the Customer Assistance Center at (800) 385-4357 after normal business hours.

We regret any inconvenience this action may cause but feel certain you understand our interest in motor vehicle safety.

WARRANTY CAMPAIGNS DEPARTMENT

Enclosure

June 2019

FL816A-F

NHTSA #19V-367 (Non-School Bus)

NHTSA #19V-368 (School Bus)

Transport Canada #2019-227 (Non-School Bus)

Reimbursement to Customers for Repairs Performed Prior to Recall

If you have already **paid** to have this recall condition corrected you may be eligible to receive reimbursement.

Requests for reimbursement may include parts and labor. Reimbursement may be limited to the amount the repair would have cost if completed by an authorized Daimler Trucks North America LLC dealer. The following documentation must be presented to your dealer for consideration for reimbursement.

Please provide original or clear copies of all receipts, invoices, and repair orders that show:

- The name and address of the person who paid for the repair
- The Vehicle Identification Number (VIN) of the vehicle that was repaired
- What problem occurred, what repair was done, when the repair was done
- Who repaired the vehicle
- The total cost of the repair expense that is being claimed
- Proof of payment for the repair (such as the front and back of a cancelled check or a credit card receipt)

Reimbursement will be made by check from your Daimler Trucks North America LLC dealer.

Please speak with your Daimler Trucks North America LLC authorized dealer concerning this matter.

June 2019
FL816A-F
NHTSA #19V-367 (Non-School Bus)
NHTSA #19V-368 (School Bus)
Transport Canada #2019-227 (Non-School Bus)

Work Instructions

Subject: Caliper Mounting Bolts

Models Affected: Specific Freightliner 108SD, 114SD, Argosy, Business Class M2, Cascadia, and Columbia vehicles; Western Star 5700 vehicles; Freightliner Custom Chassis B2 school bus chassis (Thomas Built Buses Saf-T-Liner C2) and X-Line chassis manufactured August 20, 2018, through September 29, 2018, and equipped with air disc brakes.

General Information

IMPORTANT: Vehicles may have both **axial and radial** mounted calipers. Follow the work instructions based on the type of calipers on the vehicle:

- **NOTE:** XC motorhome chassis have ZF independent front axles. No work is needed on ZF front axle calipers. Inspect/repair the Bendix rear axle calipers only.

Caliper Type	Campaign Group Letter/Axle Position	Page Number
Bendix Axial	FL816A (Front/Rear)	6
Bendix Axial (with radial runout)	FL816E (Rear)	18
Bendix Radial	FL816B (Front/Rear) F (Front/Rear)	10
Meritor Axial	FL816C (Front/Rear)	14
Wabco Axial	FL816D (Front/Rear)	16

Table 3

Front and/or Rear Caliper/Carrier Assembly Inspection and Installation - Bendix Axial Mounted Calipers

1. Check the base label (Form WAR259) for a completion sticker for FL816 (Form WAR260) indicating this work has been done. The base label is usually located on the passenger-side door, about 12 inches (30 cm) below the door latch. If a sticker is present for FL816, no work is needed. If there is no sticker, proceed with the next step.
2. Park the vehicle on a level surface, shut down the engine, and set the parking brake. Chock the tires.

DANGER

When working on the vehicle, shut down the engine, set the parking brake, and chock the tires. Before working under the vehicle, always place jack stands under the frame rails to ensure the vehicle cannot drop. Failure to follow these steps could result in serious personal injury or death.

3. Raise the vehicle and support it on jack stands.
4. Remove all of the wheel assemblies.

NOTE: In all steps that require a torque wrench, use a Snap On torque wrench ATECH4RS600, or an equivalent, with a center to handle length of 47 inches (119 cm).

5. Set a torque wrench to 350 lbf-ft (475 N·m) and tighten the caliper mounting bolts. If they do not turn, go to step 13. If they turn, continue to step 6. Due to limited caliper bolt access, it may be necessary to use tool DDC DSNCHA018005 referenced in tool letter 18TL18. See [Fig. 1](#). If the tool is needed, use tool DDC DSNCHA018005 only and no other tools. For torque specifications, see [Table 4](#) for a 47 in (119 cm) long wrench.

June 2019
FL816A-F
NHTSA #19V-367 (Non-School Bus)
NHTSA #19V-368 (School Bus)
Transport Canada #2019-227 (Non-School Bus)



Fig. 1, DDC DSNCHA018005 30mm Air Disc Brake Caliper Brake Bolt Torque Adaptor

Torque Check with 47 Inch (119 cm) Torque Wrench and Tool DDC DSNCHA018005			
Angle View	Extension Angle (degrees)	Target Torque [lbf-ft (N·m)]	Tool Setting [lbf-ft (N·m)]
<p>0° 11/28/2016 f422613</p>	0	350 (475)	296 (401)
<p>45° 11/28/2016 f422614</p>	45		310 (420)
<p>60° 11/06/2018 f422668</p>	60		320 (434)
<p>90° 11/28/2016 f422615</p>	90		350 (475)
<p>120° 11/06/2018 f422669</p>	120		386 (523)
<p>135° 11/28/2016 f422616</p>	135		402 (545)

Table 4, Torque Check with 47 Inch (119 cm) Torque Wrench and Tool DDC DSNCHA018005

June 2019
FL816A-F
NHTSA #19V-367 (Non-School Bus)
NHTSA #19V-368 (School Bus)
Transport Canada #2019-227 (Non-School Bus)

WARNING

When replacing brake pads, shoes, rotors, or drums, always replace components as an axle set.

- Always reline both sets of brakes on an axle at the same time.
- Always replace both rotors/drums on an axle at the same time.
- Always install the same type of linings/pads or drums/rotors on both axle ends of a single axle, and all four axle ends of a tandem axle, at the same time. Do not mix component types.

Failure to do so could cause uneven braking and loss of vehicle control, resulting in property damage, personal injury, or death.

6. Remove the retainer pin, cotter pin, and brake pad retainer. Inspect the brake pad hardware to ensure it is in good condition. If it is, reuse the brake pad hardware. If the brake pad hardware is not in good condition, replace brake pad sets on both ends of the axle.
7. Remove the brake pads.
8. Remove caliper bolts.

IMPORTANT: The caliper/carrier assemblies are left and right handed. Ensure that the correct assembly (left or right) is installed on each side of the vehicle.

9. Align each caliper/carrier assembly with the rotor by pushing the caliper against the shelf on the torque plate, then install the caliper/carrier assembly using new caliper mounting bolts. See [Fig. 2](#).

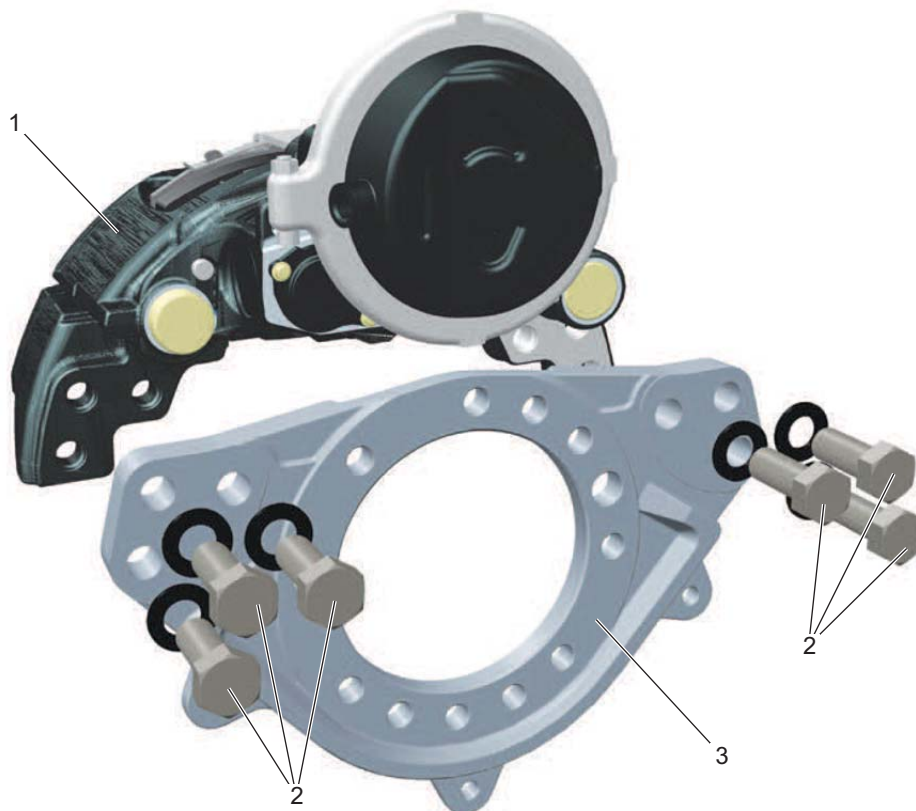

10/01/2018

f422664

1. Caliper/Carrier Assembly (showing service actuator)
2. Mounting Bolts and Washers (qty. 6)

3. Anchor Plate/Torque Plate

Fig. 2, Bendix Axial Mounted Caliper

June 2019
FL816A-F
NHTSA #19V-367 (Non-School Bus)
NHTSA #19V-368 (School Bus)
Transport Canada #2019-227 (Non-School Bus)

10. Tighten the carrier mounting bolts in two steps as follows.

- 10.1 Start on one side of the caliper and tighten all three bolts 40 ± 20 lbf-ft (54 ± 27 N·m), beginning with the inner-most bolt and moving to the outer-most bolt. Then tighten the three bolts on the other side of the caliper 40 ± 20 lbf-ft (54 ± 27 N·m), beginning with the inner-most bolt and moving to the outer-most bolt. See [Fig. 3](#).



Fig. 3, Tightening Pattern, Bendix Axial Caliper

- 10.2 Repeat this process, increasing the torque value to 375 ± 25 lbf-ft (508 ± 34 N·m). If the tool DDC DSN-CHA018005 referenced in tool letter 18TL18 is used, see [Table 5](#) for torque specifications.

Bendix/Wabco Installation with a 47 Inch (119 cm) Torque Wrench and Tool DDC DSNCHA018005			
Angle View	Extension Angle (degrees)	Target Torque [lbf-ft (N·m)]	Tool Setting [lbf-ft (N·m)]
<p>0° 11/28/2016 f422613</p>	0	375 (508)	317 (430)
<p>45° 11/28/2016 f422614</p>	45		332 (450)
<p>60° 11/06/2018 f422668</p>	60		343 (465)
<p>90° 11/28/2016 f422615</p>	90		375 (508)
<p>120° 11/06/2018 f422669</p>	120		413 (560)
<p>135° 11/28/2016 f422616</p>	135		431 (584)

Table 5, Bendix/Wabco Installation with a 47 Inch (119 cm) Torque Wrench and Tool DDC DSNCHA018005

June 2019
FL816A-F
NHTSA #19V-367 (Non-School Bus)
NHTSA #19V-368 (School Bus)
Transport Canada #2019-227 (Non-School Bus)

NOTICE

Do not use a motor driven tool to tighten the manual brake adjuster nut, or use excessive force to tighten the nut. Doing so could damage the manual brake adjuster nut.

11. Install the brake pads. Provided it is in good condition, use the brake pad hardware removed earlier.
12. Back off the adjuster nut three clicks.
13. Install the wheel assemblies.
14. Raise the vehicle, remove the jack stands, then lower the vehicle.
15. Charge the air system and check for leaks.

WARNING

Do not operate the vehicle until the brakes have been adjusted and checked for proper operation. To do so could result in inadequate or no braking ability, which could cause personal injury or death, and property damage.

16. In a safe area, check for proper brake operation, as follows, before putting the vehicle in service.
 - 16.1 Apply and release the brakes several times to check for air leaks and proper operation.
 - 16.2 Perform six low-speed stops to ensure proper parts replacement and full vehicle control.
 - 16.3 Immediately after doing the above stops, check the rotor temperatures. Any rotors that are significantly cooler than others indicate a lack of braking effort on those wheels.
17. Clean a spot on the base label (Form WAR259). Write the recall number, FL816, on a completion sticker (Form WAR260), and attach it to the base label to indicate this recall has been completed.

Front and/or Rear Caliper/Carrier Assembly Inspection and Installation - Bendix Radial Mounted Calipers

1. Check the base label (Form WAR259) for a completion sticker for FL816 (Form WAR260) indicating this work has been done. The base label is usually located on the passenger-side door, about 12 inches (30 cm) below the door latch. If a sticker is present for FL816, no work is needed. If there is no sticker, proceed with the next step.
2. Park the vehicle on a level surface, shut down the engine, and set the parking brake. Chock the tires.

DANGER

When working on the vehicle, shut down the engine, set the parking brake, and chock the tires. Before working under the vehicle, always place jack stands under the frame rails to ensure the vehicle cannot drop. Failure to follow these steps could result in serious personal injury or death.

3. Raise the vehicle and support it on jack stands.
4. Remove all of the wheel assemblies.

NOTE: In all steps that require a torque wrench, use a Snap On torque wrench ATECH4RS600, or an equivalent, with a center-to-handle length of 47 inches (119 cm).

5. Set a torque wrench to 200 lbf-ft (271 N-m) and tighten the caliper mounting bolts. If they do not turn, go to step 13. If they turn, continue to step 6.

June 2019
FL816A-F
NHTSA #19V-367 (Non-School Bus)
NHTSA #19V-368 (School Bus)
Transport Canada #2019-227 (Non-School Bus)

⚠ WARNING

When replacing brake pads, shoes, rotors, or drums, always replace components as an axle set.

- Always reline both sets of brakes on an axle at the same time.
- Always replace both rotors/drums on an axle at the same time.
- Always install the same type of linings/pads or drums/rotors on both axle ends of a single axle, and all four axle ends of a tandem axle, at the same time. Do not mix component types.

Failure to do so could cause uneven braking and loss of vehicle control, resulting in property damage, personal injury, or death.

6. Remove the retainer pin, cotter pin, and brake pad retainer. Inspect the brake pad hardware to ensure it is in good condition. If it is, reuse the brake pad hardware. If the brake pad hardware is not in good condition, replace brake pad sets on both ends of the axle.
7. Remove the brake pads.
8. Remove caliper bolts.

IMPORTANT: The caliper/carrier assemblies are left and right handed. Ensure that the correct assembly (left or right) is installed on each side of the vehicle.

9. Align each caliper/carrier assembly with the rotor by pushing the fixed pin side of the caliper against the shelf on the torque plate, then install the caliper/carrier assembly using new caliper mounting bolts. See Fig. 4.

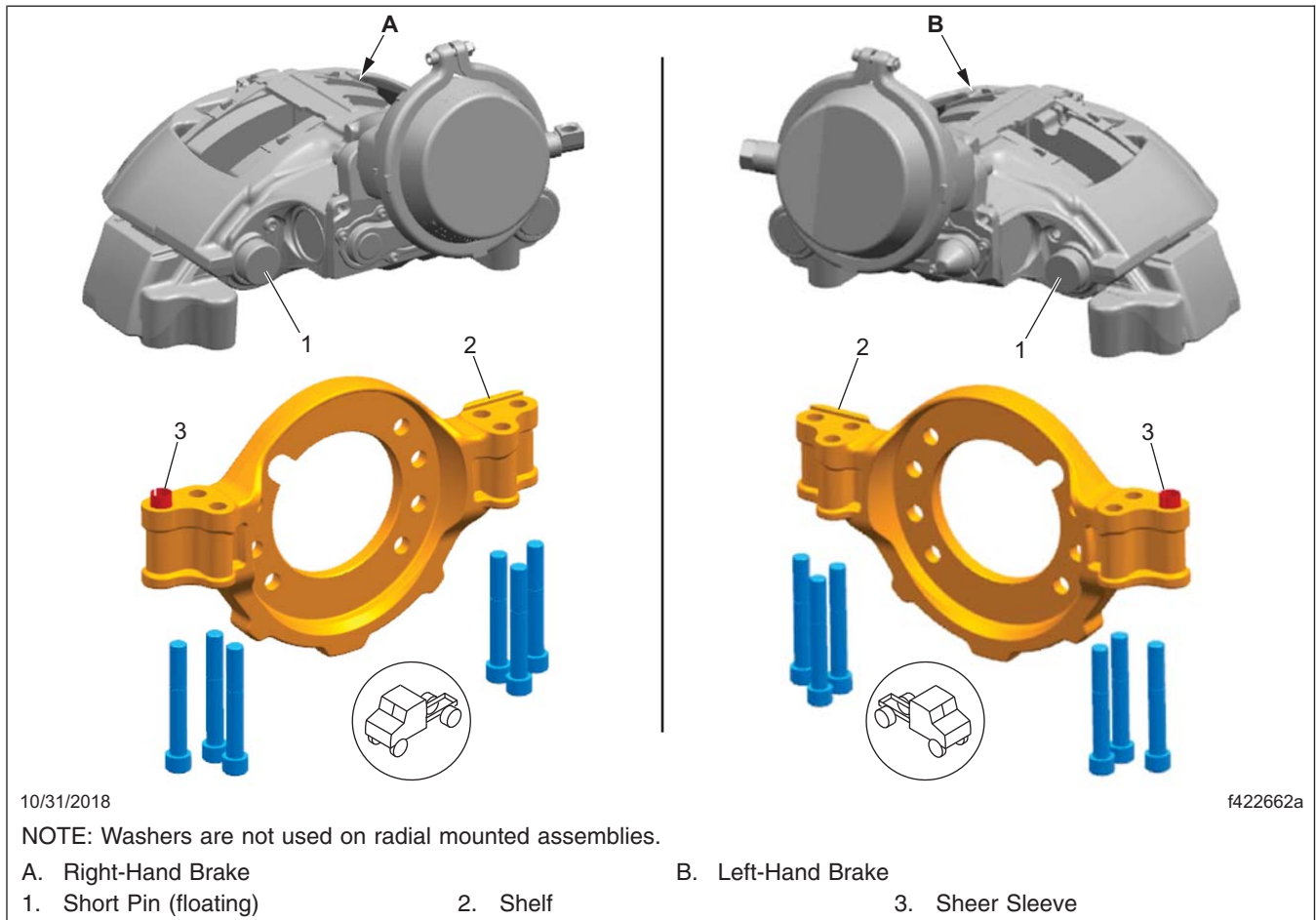

Fig. 4, Bendix Radial Mounted Caliper

June 2019
FL816A-F
NHTSA #19V-367 (Non-School Bus)
NHTSA #19V-368 (School Bus)
Transport Canada #2019-227 (Non-School Bus)

NOTE: The tightening pattern will always start on the short (floating) pin side, with the bolt that passes through the shear sleeve.

10. Tighten the carrier mounting bolts in two steps, using the pattern shown in **Fig. 5**.

NOTE: A slide-ability test must be performed in the green zone (marked as 'A'), shown in **Fig. 6**, as the red zones are not within operational range.

10.1 Initially tighten all six bolts 45 ± 5 lbf-ft (61 ± 7 N·m). Slide the caliper inboard and outboard, through the center of the chamber or brake. The caliper must have a minimum of 20 mm of travel. If the brake assembly does not move, or requires more than 40 pounds of force to move, the caliper has a binding issue. File a WSC ticket for instructions.

10.2 Perform a final tightening spec of 225 ± 22.5 lbf-ft (305 ± 31 N·m). Slide the caliper inboard and outboard, through the center of the chamber or brake. The caliper must have a minimum of 20 mm of travel. If the brake assembly does not move, or requires more than 40 pounds of force to move, the caliper has a binding issue. File a WSC ticket for instructions.

NOTICE

Do not use a motor driven tool to tighten the manual brake adjuster nut, or use excessive force to tighten the nut. Doing so could damage the manual brake adjuster nut.

11. Install the brake pads. Provided it is in good condition, use the brake pad hardware removed earlier.

12. Back off the adjuster nut three clicks.

13. Install the wheel assemblies.

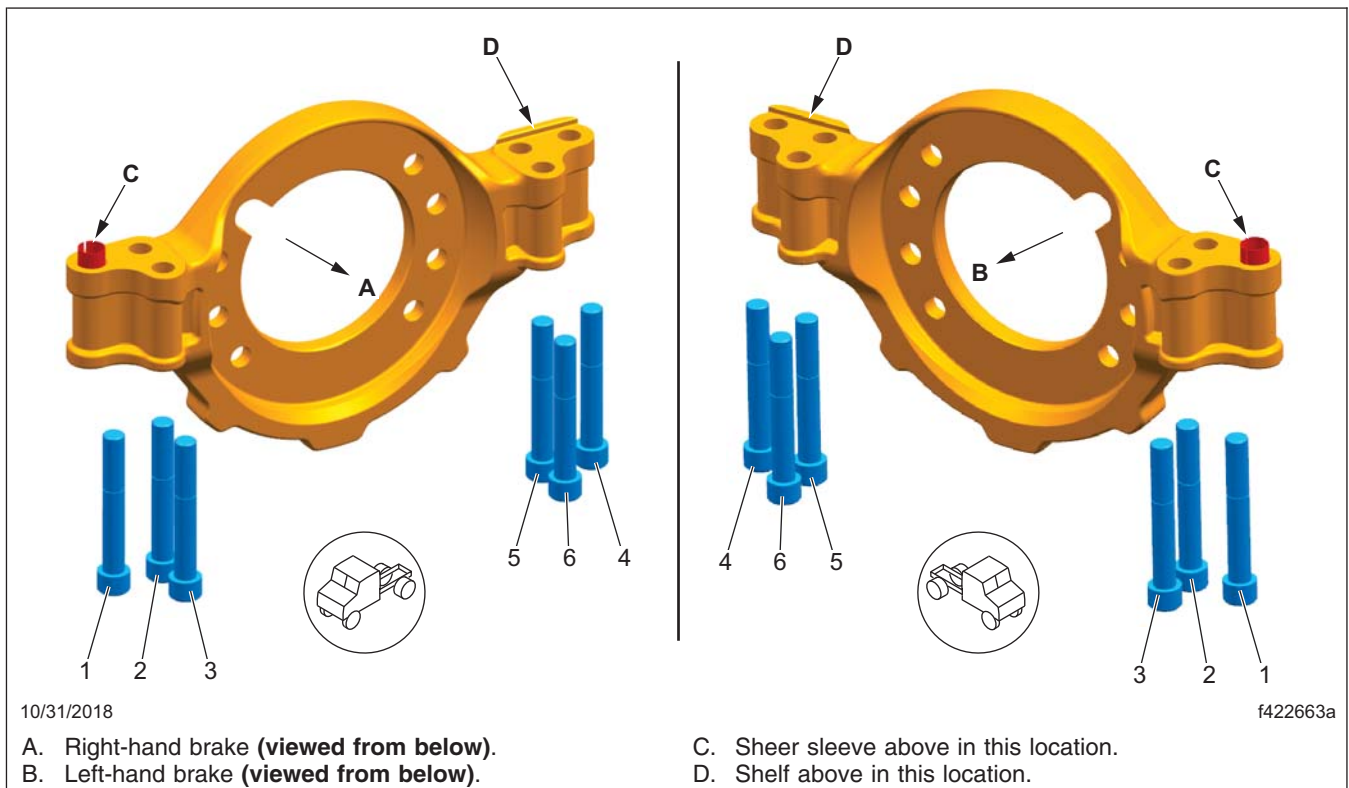

Fig. 5, Tightening Pattern (viewed from below), Bendix Radial Mounted Caliper

June 2019
FL816A-F
NHTSA #19V-367 (Non-School Bus)
NHTSA #19V-368 (School Bus)
Transport Canada #2019-227 (Non-School Bus)

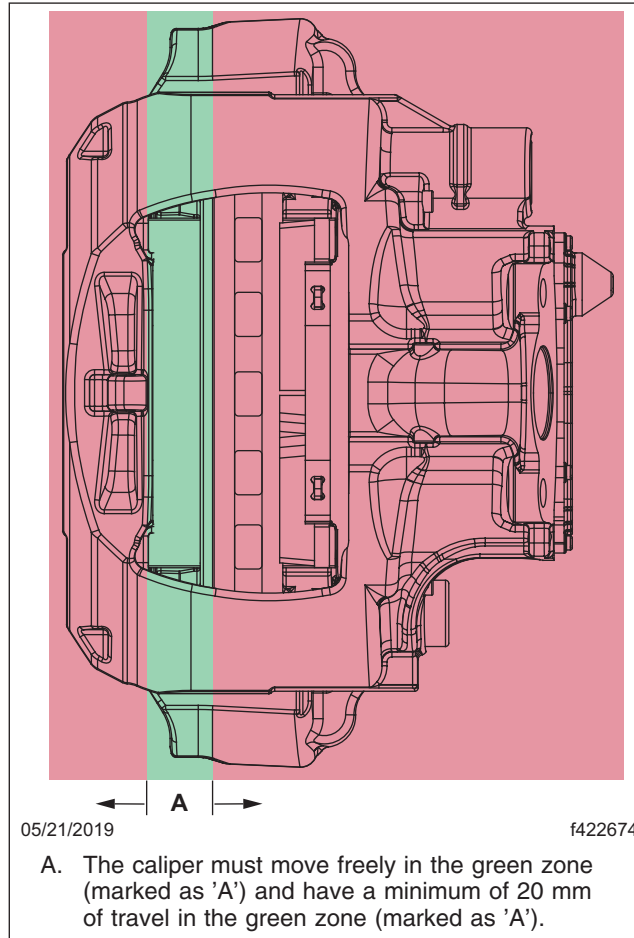

Fig. 6, Slide-Ability Test Area

14. Raise the vehicle, remove the jack stands, then lower the vehicle.
15. Charge the air system and check for leaks.

⚠ WARNING

Do not operate the vehicle until the brakes have been adjusted and checked for proper operation. To do so could result in inadequate or no braking ability, which could cause personal injury or death, and property damage.

16. In a safe area, check for proper brake operation, as follows, before putting the vehicle in service.
 - 16.1 Apply and release the brakes several times to check for air leaks and proper operation.
 - 16.2 Perform six low-speed stops to ensure proper parts replacement and full vehicle control.
 - 16.3 Immediately after doing the above stops, check the rotor temperatures. Any rotors that are significantly cooler than others indicate a lack of braking effort on those wheels.

June 2019
FL816A-F
NHTSA #19V-367 (Non-School Bus)
NHTSA #19V-368 (School Bus)
Transport Canada #2019-227 (Non-School Bus)

17. Clean a spot on the base label (Form WAR259). Write the recall number, FL816, on a completion sticker (Form WAR260), and attach it to the base label to indicate this recall has been completed.

Front and/or Rear Caliper/Carrier Assembly Inspection and Installation - Meritor Axial Mounted Calipers

1. Check the base label (Form WAR259) for a completion sticker for FL816 (Form WAR260) indicating this work has been done. The base label is usually located on the passenger-side door, about 12 inches (30 cm) below the door latch. If a sticker is present for FL816, no work is needed. If there is no sticker, proceed with the next step.
2. Park the vehicle on a level surface, shut down the engine, and set the parking brake. Chock the tires.

DANGER

When working on the vehicle, shut down the engine, set the parking brake, and chock the tires. Before working under the vehicle, always place jack stands under the frame rails to ensure the vehicle cannot drop. Failure to follow these steps could result in serious personal injury or death.

3. Raise the vehicle and support it on jack stands.
4. Remove all of the wheel assemblies.

NOTE: In all steps that require a torque wrench, use a Snap On torque wrench ATECH4RS600, or an equivalent, with a center to handle length of 47 inches (119 cm).

5. Set a torque wrench to 350 lbf-ft (475 N·m) and tighten the caliper mounting bolts. If they do not turn, go to step 13. If they turn, continue to step 6. Due to limited caliper bolt access, it may be necessary to use tool DDC DSNCHA018005 referenced in tool letter 18TL18. If the tool is needed, use tool DDC DSN-CHA018005 only and no other tools. See [Table 4](#) for torque specifications.

WARNING

When replacing brake pads, shoes, rotors, or drums, always replace components as an axle set.

- Always reline both sets of brakes on an axle at the same time.
- Always replace both rotors/drums on an axle at the same time.
- Always install the same type of linings/pads or drums/rotors on both axle ends of a single axle, and all four axle ends of a tandem axle, at the same time. Do not mix component types.

Failure to do so could cause uneven braking and loss of vehicle control, resulting in property damage, personal injury, or death.

6. Remove the retainer pin, cotter pin, and brake pad retainer. Inspect the brake pad hardware to ensure it is in good condition. If it is, reuse the brake pad hardware. If the brake pad hardware is not in good condition, replace brake pad sets on both ends of the axle.
7. Remove the brake pads.
8. Remove caliper bolts.

IMPORTANT: The caliper/carrier assemblies are left and right handed. Ensure that the correct assembly (left or right) is installed on each side of the vehicle.

NOTE: The Meritor axial mounted caliper is similar to the Bendix axial mounted caliper shown in [Fig. 2](#).

9. Align each caliper/carrier assembly with the rotor by pushing the caliper against the shelf on the torque plate, then install the caliper/carrier assembly using new caliper mounting bolts.

June 2019
 FL816A-F
 NHTSA #19V-367 (Non-School Bus)
 NHTSA #19V-368 (School Bus)
 Transport Canada #2019-227 (Non-School Bus)

10. Tighten the carrier mounting bolts in two steps as follows.
 - 10.1 Start on one side of the caliper and tighten all of the bolts 45 ± 5 lbf-ft (61 ± 7 N·m). Then tighten the bolts on the other side of the caliper 45 ± 5 lbf-ft (61 ± 7 N·m). See [Fig. 3](#).
 - 10.2 Repeat this process, increasing the torque value to 400 ± 50 lbf-ft (542 ± 68 N·m). If tool DDC DSN-CHA018005 referenced in tool letter 18TL18 is used, see [Table 6](#) for torque specifications.





Meritor Installation with a 47 Inch (119 cm) Torque Wrench and Tool DDC DSNCHA018005			
Angle View	Extension Angle (degrees)	Target Torque [lbf-ft (N·m)]	Tool Setting [lbf-ft (N·m)]
 11/28/2016 f422613	0	400 (542)	338 (458)
 11/28/2016 f422614	45		354 (480)
 11/06/2018 f422668	60		366 (496)
 11/28/2016 f422615	90		400 (542)
 11/06/2018 f422669	120		441 (598)
 11/28/2016 f422616	135		460 (624)

Table 6, Meritor Installation with a 47 Inch (119 cm) Torque Wrench and Tool DDC DSNCHA018005

June 2019
FL816A-F
NHTSA #19V-367 (Non-School Bus)
NHTSA #19V-368 (School Bus)
Transport Canada #2019-227 (Non-School Bus)

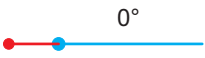
NOTICE

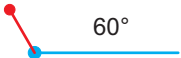
Do not use a motor driven tool to tighten the manual brake adjuster nut, or use excessive force to tighten the nut. Doing so could damage the manual brake adjuster nut.

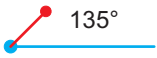
11. Install the brake pads. Provided it is in good condition, use the brake pad hardware removed earlier.
12. Back off the adjuster nut three clicks.
13. Install the wheel assemblies.
14. Raise the vehicle, remove the jack stands, then lower the vehicle.
15. Charge the air system and check for leaks.

 **WARNING**

Do not operate the vehicle until the brakes have been adjusted and checked for proper operation. To do so could result in inadequate or no braking ability, which could cause personal injury or death, and property damage.

16. In a safe area, check for proper brake operation, as follows, before putting the vehicle in service.
 - 16.1 Apply and release the brakes several times to check for air leaks and proper operation.
 - 16.2 Perform six low-speed stops to ensure proper parts replacement and full vehicle control.
 - 16.3 Immediately after doing the above stops, check the rotor temperatures. Any rotors that are significantly cooler than others indicate a lack of braking effort on those wheels.
17. Clean a spot on the base label (Form WAR259). Write the recall number, FL816, on a completion sticker (Form WAR260), and attach it to the base label to indicate this recall has been completed.

Front and/or Rear Caliper/Carrier Assembly Inspection and Installation - Wabco Maxxus Axial Mounted Calipers

1. Check the base label (Form WAR259) for a completion sticker for FL816 (Form WAR260) indicating this work has been done. The base label is usually located on the passenger-side door, about 12 inches (30 cm) below the door latch. If a sticker is present for FL816, no work is needed. If there is no sticker, proceed with the next step.
2. Park the vehicle on a level surface, shut down the engine, and set the parking brake. Chock the tires.

 **DANGER**

When working on the vehicle, shut down the engine, set the parking brake, and chock the tires. Before working under the vehicle, always place jack stands under the frame rails to ensure the vehicle cannot drop. Failure to follow these steps could result in serious personal injury or death.

3. Raise the vehicle and support it on jack stands.
4. Remove all of the wheel assemblies.

NOTE: In all steps that require a torque wrench, use a Snap On torque wrench ATECH4RS600, or an equivalent, with a center to handle length of 47 inches (119 cm).

June 2019

FL816A-F

NHTSA #19V-367 (Non-School Bus)

NHTSA #19V-368 (School Bus)

Transport Canada #2019-227 (Non-School Bus)

5. Set a torque wrench to 350 lbf·ft (475 N·m) and tighten the caliper mounting bolts. If they do not turn, go to step 13. If they turn, continue to step 6. Due to limited caliper bolt access, it may be necessary to use tool DDC DSNCHA018005 referenced in tool letter 18TL18. If the tool is needed, use tool DDC DSN-CHA018005 only and no other tools. For torque specifications, see [Table 4](#) for a 47 in (119 cm) long wrench.

WARNING

When replacing brake pads, shoes, rotors, or drums, always replace components as an axle set.

- Always reline both sets of brakes on an axle at the same time.
- Always replace both rotors/drums on an axle at the same time.
- Always install the same type of linings/pads or drums/rotors on both axle ends of a single axle, and all four axle ends of a tandem axle, at the same time. Do not mix component types.

Failure to do so could cause uneven braking and loss of vehicle control, resulting in property damage, personal injury, or death.

6. Remove the retainer pin, cotter pin, and brake pad retainer. Inspect the brake pad hardware to ensure it is in good condition. If it is, reuse the brake pad hardware. If the brake pad hardware is not in good condition, replace brake pad sets on both ends of the axle.
7. Remove the brake pads.
8. Remove caliper bolts.

IMPORTANT: The caliper/carrier assemblies are left and right handed. Ensure that the correct assembly (left or right) is installed on each side of the vehicle.

NOTE: The Wabco axial mounted caliper is similar to the Bendix axial mounted caliper shown in [Fig. 2](#).

9. Align each caliper/carrier assembly with the rotor by pushing the caliper against the shelf on the torque plate, then install the caliper/carrier assembly using new caliper mounting bolts.
10. Tighten the carrier mounting bolts in two steps as follows.
 - 10.1 Start on one side of the caliper and tighten all of the bolts 45 ± 5 lbf·ft (61 ± 7 N·m). Then tighten the bolts on the other side of the caliper 45 ± 5 lbf·ft (61 ± 7 N·m). See [Fig. 3](#).
 - 10.2 Repeat this process, increasing the torque value to 375 ± 25 lbf·ft (508 ± 34 N·m). If tool DDC DSN-CHA018005 referenced in tool letter 18TL18 is used, see [Table 5](#) for torque specifications.

NOTICE

Do not use a motor driven tool to tighten the manual brake adjuster nut, or use excessive force to tighten the nut. Doing so could damage the manual brake adjuster nut.

11. Install the brake pads. Provided it is in good condition, use the brake pad hardware removed earlier.
12. Back off the adjuster nut three clicks.
13. Install the wheel assemblies.
14. Raise the vehicle, remove the jack stands, then lower the vehicle.

June 2019
FL816A-F
NHTSA #19V-367 (Non-School Bus)
NHTSA #19V-368 (School Bus)
Transport Canada #2019-227 (Non-School Bus)

15. Charge the air system and check for leaks.

 **WARNING**

Do not operate the vehicle until the brakes have been adjusted and checked for proper operation. To do so could result in inadequate or no braking ability, which could cause personal injury or death, and property damage.

16. In a safe area, check for proper brake operation, as follows, before putting the vehicle in service.
 - 16.1 Apply and release the brakes several times to check for air leaks and proper operation.
 - 16.2 Perform six low-speed stops to ensure proper parts replacement and full vehicle control.
 - 16.3 Immediately after doing the above stops, check the rotor temperatures. Any rotors that are significantly cooler than others indicate a lack of braking effort on those wheels.
17. Clean a spot on the base label (Form WAR259). Write the recall number, FL816, on a completion sticker (Form WAR260), and attach it to the base label to indicate this recall has been completed.

Bendix Axial Caliper/Carrier Assembly Inspection and Installation - XB, XC, EFX and HDX Model Vehicles.

NOTE: XC motorhome chassis have ZF independent front axle. No work is needed on ZF front axle calipers. Inspect/repair the Bendix rear axle calipers only.

1. Check the base label (Form WAR259) for a completion sticker for FL816 (Form WAR260) indicating this work has been completed. The base label is usually located on the front wall under the dash. If a sticker is present, no work is needed. If there is no sticker, proceed with the next step.
2. Park the vehicle on a level surface, shut down the engine, and set the parking brake. Chock the tires.

 **DANGER**

When working on the vehicle, shut down the engine, set the parking brake, and chock the tires. Before working under the vehicle, always place jack stands under the frame rails to ensure the vehicle cannot drop. Failure to follow these steps could result in serious personal injury or death.

3. Raise the vehicle and place jack stands under the frame rails to ensure the vehicle cannot drop.

June 2019
FL816A-F
NHTSA #19V-367 (Non-School Bus)
NHTSA #19V-368 (School Bus)
Transport Canada #2019-227 (Non-School Bus)

4. Beginning with the right-front wheel, use a tire runout gauge to check the radial runout. See **Fig. 7**. Write down the measurement for later use to avoid vibration complaints.

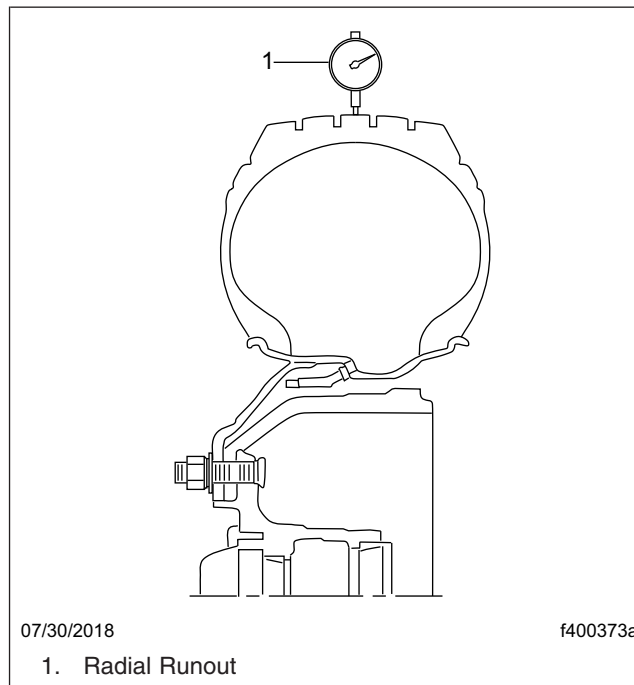

Fig. 7, Radial Runout Check for Tires

5. Mark the two studs closest to the valve stem as shown in **Fig. 8**, for proper wheel assembly location when reinstalling the wheel assembly on the hub.

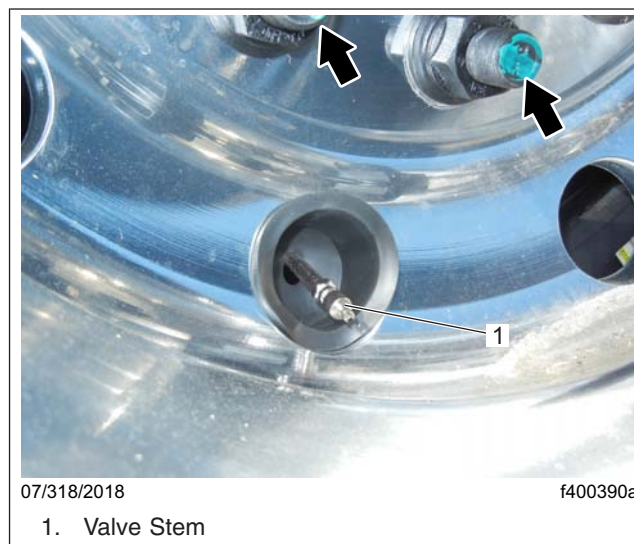

Fig. 8, Marking Wheel Studs

June 2019
FL816A-F
NHTSA #19V-367 (Non-School Bus)
NHTSA #19V-368 (School Bus)
Transport Canada #2019-227 (Non-School Bus)

6. Remove the lug nuts, then remove the wheel assembly.

IMPORTANT: Before removing the brake pads, it is recommended to check the adjuster mechanism for proper operation.

NOTE: In all steps that require a torque wrench, use a Snap On torque wrench ATECH4RS600, or an equivalent, with a center to handle length of 47 inches (119 cm).

7. Set a torque wrench to 350 lbf-ft (475 N·m) and tighten the caliper mounting bolts. If they do not turn, go to step 15. If they turn, go to step 8. Due to limited caliper bolt access, it may be necessary to use tool DDC DSNCHA018005 referenced in tool letter 18TL18. If the tool is needed, use tool DDC DSNCHA018005 only and no other tools. See [Fig. 1](#) and [Table 4](#) for torque specifications.

WARNING

When replacing brake pads, shoes, rotors, or drums, always replace components as an axle set.

- Always reline both sets of brakes on an axle at the same time.
- Always replace both rotors/drums on an axle at the same time.
- Always install the same type of linings/pads or drums/rotors on both axle ends of a single axle, and all four axle ends of a tandem axle, at the same time. Do not mix component types.

Failure to do so could cause uneven braking and loss of vehicle control, resulting in property damage, personal injury, or death.

8. Remove the retainer pin, cotter pin, and brake pad retainer. Inspect the brake pad hardware to ensure it is in good condition. If it is, reuse the brake pad hardware. If the brake pad hardware is not in good condition, replace brake pad sets on both ends of the axle.
9. Remove the brake pads.
10. Remove the caliper bolts and washers (if installed) and discard.

IMPORTANT: The caliper/carrier assemblies are left and right handed. Ensure that the correct assembly (left or right) is installed on each side of the vehicle.

11. Align the caliper/carrier assembly with the rotor, pushing the caliper against the shelf on the torque plate, then install the caliper/carrier assembly using new caliper mounting bolts and washers. See [Table 1](#) for parts information. See [Fig. 2](#) for an example of the front caliper/carrier assembly.
12. Tighten the M20 X 2.5 carrier mounting bolts as follows. See [Fig. 3](#).
 - 12.1 Start on one side of the caliper and tighten all three bolts 40±20 lbf-ft (54±27 N·m), beginning with the inner-most bolt and moving to the outer-most bolt. Then tighten the three bolts on the other side of the caliper 40±20 lbf-ft (54±27 N·m), beginning with the inner-most bolt and moving to the outer-most bolt.
 - 12.2 Repeat this process, increasing the torque value to 375±25 lbf-ft (508±34 N·m). If tool DDC DSNCHA018005 referenced in tool letter 18TL18 is used, see [Table 5](#) for torque specifications.

NOTICE

Do not use a motor driven tool to tighten the manual brake adjuster nut, or use excessive force to tighten the nut. Doing so could damage the manual brake adjuster nut.

13. Install the brake pads. Provided it is good condition, use the brake pad hardware removed earlier.
14. Back off the adjuster nut three clicks.

June 2019
FL816A-F
NHTSA #19V-367 (Non-School Bus)
NHTSA #19V-368 (School Bus)
Transport Canada #2019-227 (Non-School Bus)

15. Using the two studs marked earlier as a guide, install the wheel assembly. When correctly installed, a line drawn from the valve stem through the center of the wheel assembly should go between the two marked studs.
16. Using a tire runout gauge, measure and record the radial runout of the tire and wheel assembly. Mark the highest point on the tire and wheel assembly. Rotate the tire and wheel assembly until the high spot is at the 12 o'clock position (without allowing the assembly to turn). Loosen all lug nuts to let the assembly settle, then tighten the lug nuts in the proper sequence. See **Group 40** of the applicable vehicle maintenance manual for the tightening sequence. The radial runout should be very close to what was recorded in step 3. If not, repeat this step. Record the "final" radial runout, note the wheel location, and include the information in the recall claim in OWL.
17. Perform the steps above for each wheel location (as needed based on the population letter) until all wheel locations have been inspected and repaired if needed.
18. Raise the vehicle, remove the jack stands, then lower the vehicle.
19. Charge the air system and check for leaks.

 **WARNING**

Do not operate the vehicle until the brakes have been adjusted and checked for proper operation. To do so could result in inadequate or no braking ability, which could cause personal injury or death, and property damage.

20. In a safe area, check for proper brake operation, as follows, before putting the vehicle in service.
 - 20.1 Apply and release the brakes several times to check for air leaks and proper operation.
 - 20.2 Perform six low-speed stops to ensure proper parts replacement and full vehicle control.
 - 20.3 Immediately after doing the above stops, check the rotor temperatures. Any rotors that are significantly cooler than others indicate a lack of braking effort on those wheels.
21. Clean a spot on the base label (Form WAR259), write the recall number, FL816, on a red completion sticker (Form WAR260), and attach it to the base label, indicating this work has been completed.