

NOTE: This repair procedure includes all model years from 2009-2013

■ FRONT CROSSMEMBER REMOVAL/INSTALLATION [MZI-3.7 (V6 engine)]

Follow this method for removing the Front Cross Member.

- Do not drain the P/S fluid or disconnect the power steering line
- Do not remove the steering shaft cover and bolt
- Do not remove the outer tie rod ends
- Do not remove the sway bar end links.

1. Remove the front wheels
2. Remove the front mudguard. (see FRONT MUDGUARD REMOVAL/INSTALLATION)
3. Remove the splash shield (RH)
4. Spray all bolts with a penetrating oil
5. Remove the power steering hose support bolts

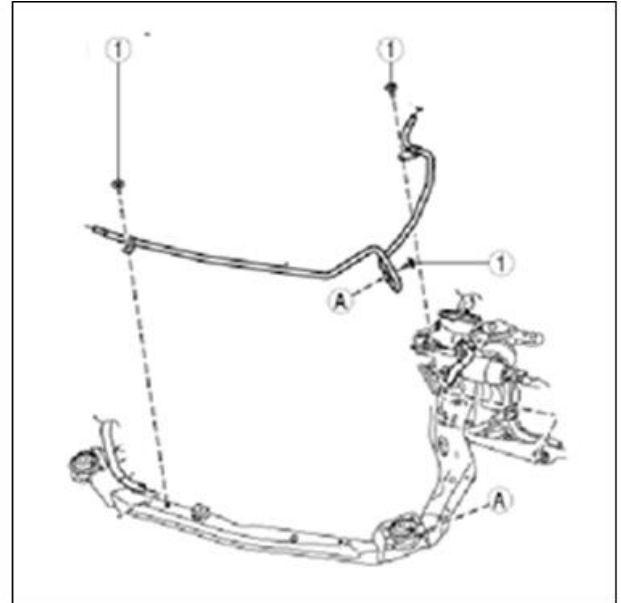
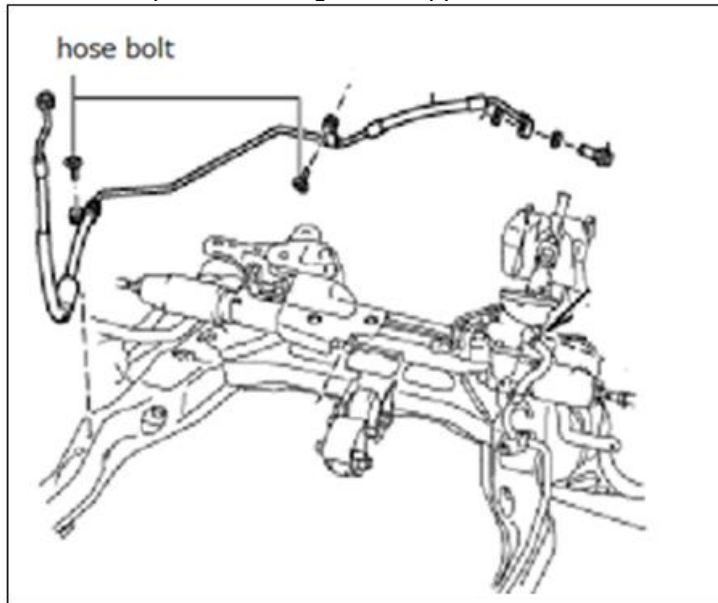

6. Remove the front pipe. (see EXHAUST SYSTEM REMOVAL/INSTALLATION)
7. Remove the No.1 engine mount. (See the Front Lower Arm Outer Side Nut Removal Note)

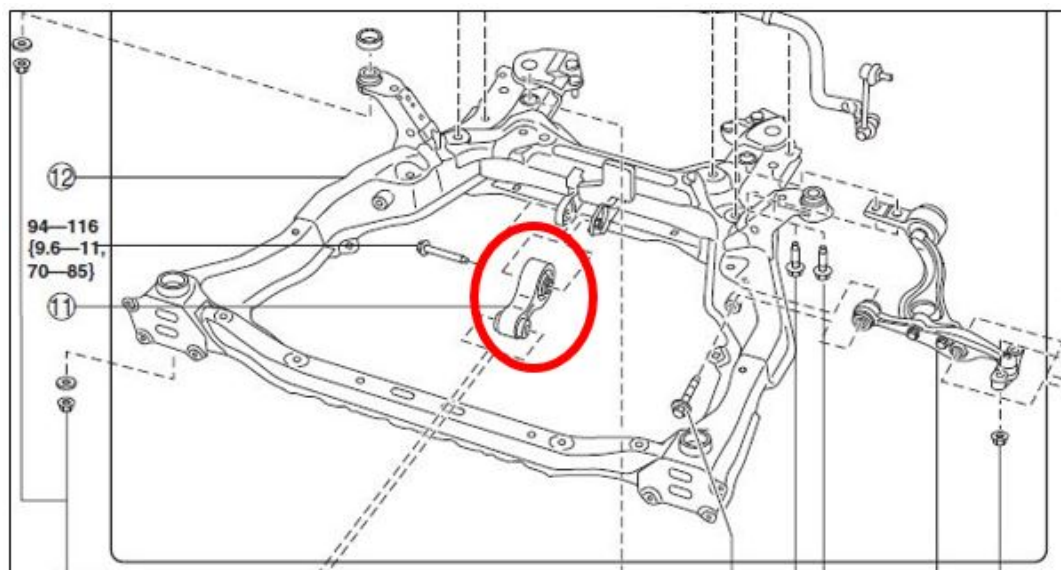

8. Remove the cross member bracket.

9. Remove both lower arm bolt, and nuts x 2

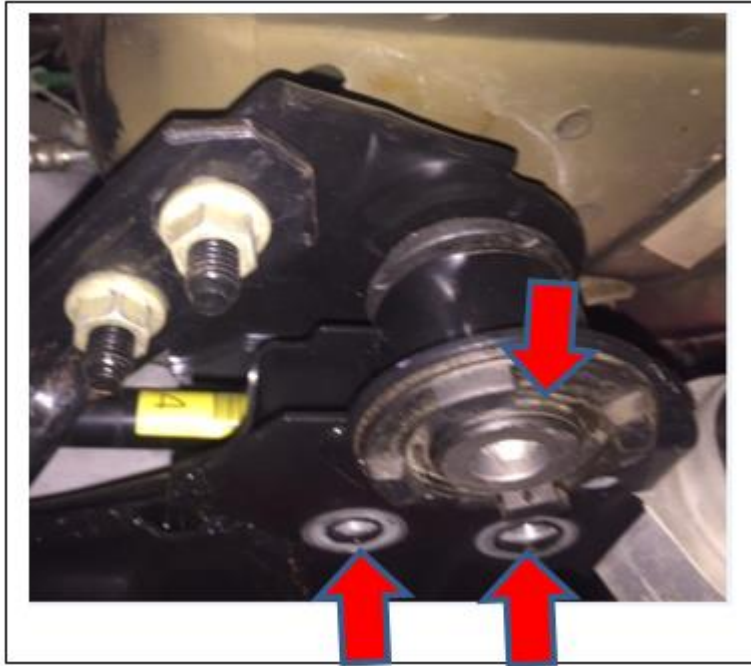

10. Support the Front Cross Member

11. Remove the rear Cross Member Bolts and Nuts to allow the rear portion of the Front Cross Member to drop



about 1 inch to access the bolts.

12. Remove the 3 Power Steering rack bolts. You will need a 15 mm ratcheting wrench to access the one driver's side bolt. Lift up on the steering rack on the left side until the bolt is free from the cross member

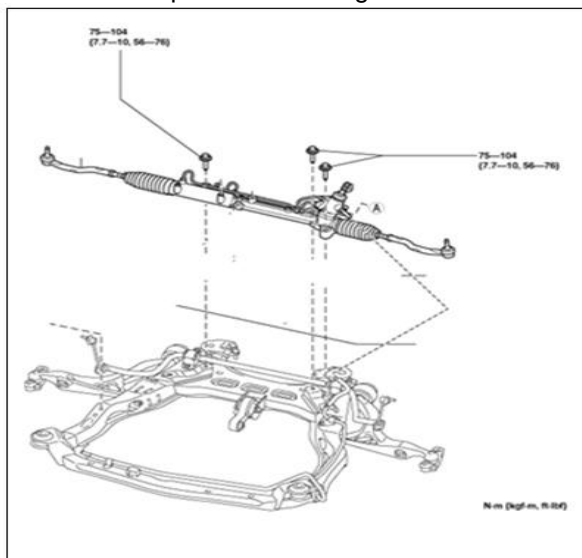

13. Remove the 4 Sway Bar center bracket bolts. You will need a 13mm ratcheting wrench to access the 2 rear



center bracket bolts.

14. Once the rack and the sway bar are free from the front cross member support them with a bungee cord or equivalent to prevent stress to the components and P/S hose.

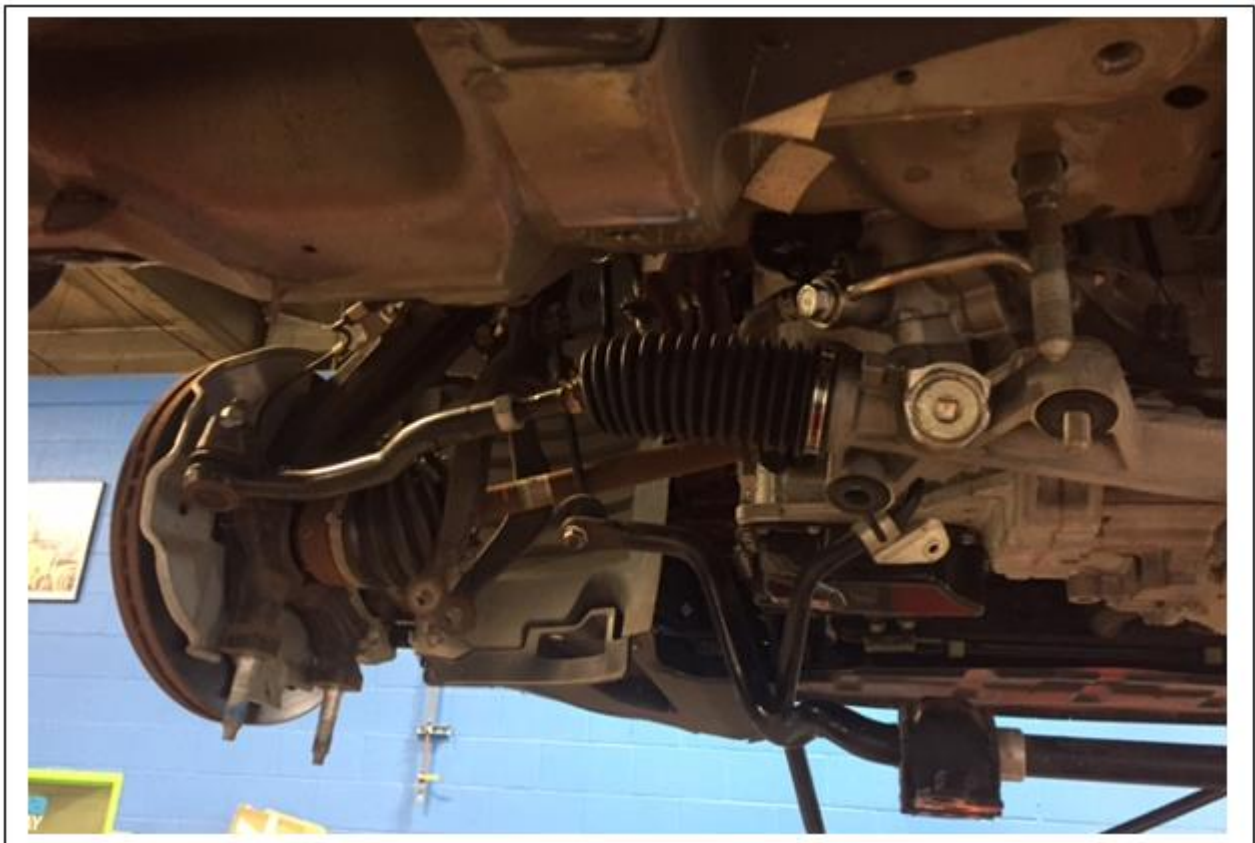

15. If the Power Steering rack bolts or the Sway Bar center bracket bolts are frozen, use additional force to shear the bolt, Replace with new bolts when installing the new front cross member
16. With the Front Cross Member supported, remove the front cross member nuts and lower carefully to the ground
17. Remove both lower arms from the front cross member
- 18. Go to A/C Drain hose installation procedure and follow steps 10-13.**
19. Remove in the order indicated in the table. (See FRONT CROSSMEMBER REMOVAL/INSTALLATION)
20. Install in the reverse order of removal. In order to torque the two rear sway bar bracket bolts and the one driver's side steering rack bolt, you will need to use a 15mm and a 13mm crows foot wrench.
21. Be sure the A/C drain hose is behind the P/S hose as outlined in step 12.
22. Inspect the front wheel alignment. (See FRONT WHEEL ALIGNMENT.)
23. Go to A/C Drain hose installation procedure and follow step 14 to confirm proper operation.

FRONT MUDGUARD REMOVAL/INSTALLATION

1. Remove screws A and tab B, and set the front mudguard out of the way in the direction of the arrow shown in the figure.

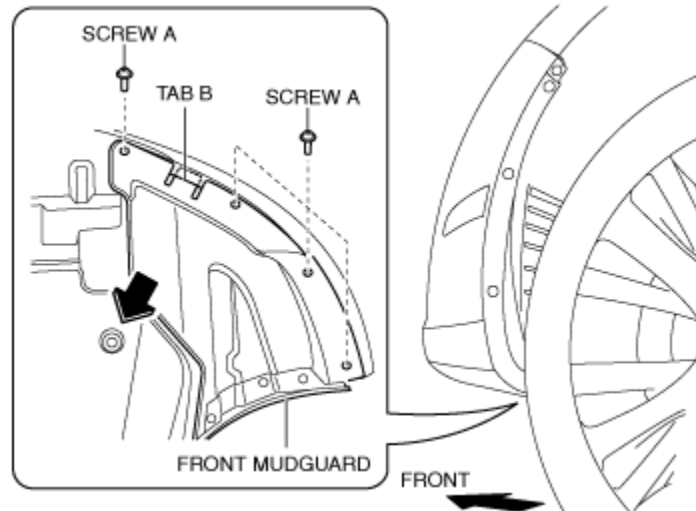

2. Remove fasteners C, E, F and screws D.

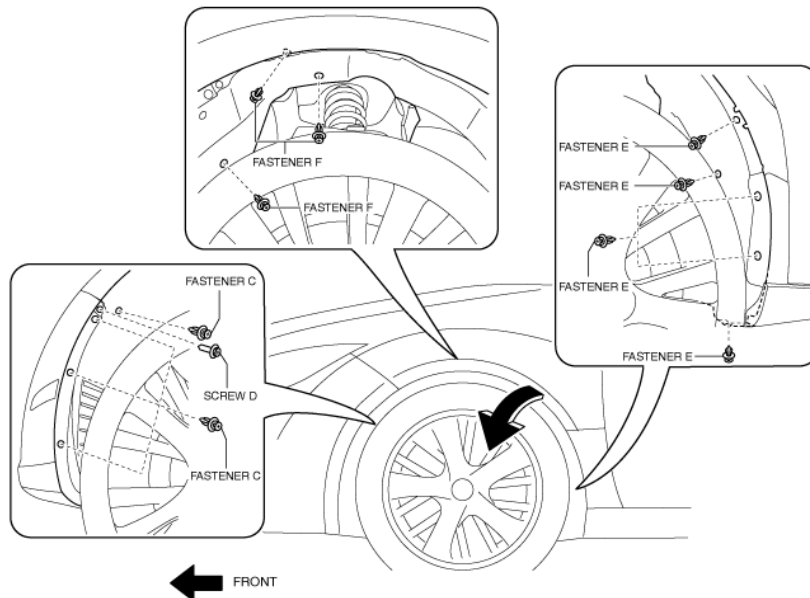

Install in the reverse order of removal

EXHAUST SYSTEM REMOVAL/INSTALLATION

Warning

- When the engine and exhaust system are hot, they can badly burn. Turn off the engine and wait until they are cool before removing the exhaust system.

1. Disconnect the negative battery cable.
2. Remove the front pipe.
3. Install in the reverse order of removal.

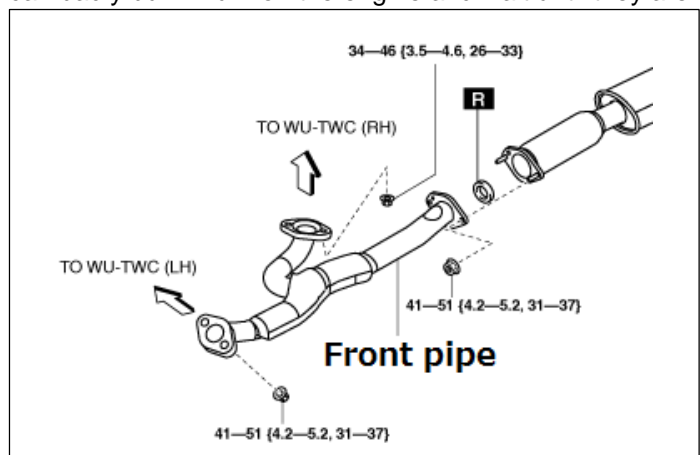

FRONT CROSSMEMBER REMOVAL/INSTALLATION - REFER TO THE MODIFIED INSTRUCTIONS

1. Remove in the order indicated in the table.
2. Install in the reverse order of removal.
3. Inspect the front wheel alignment. (See FRONT WHEEL ALIGNMENT.)

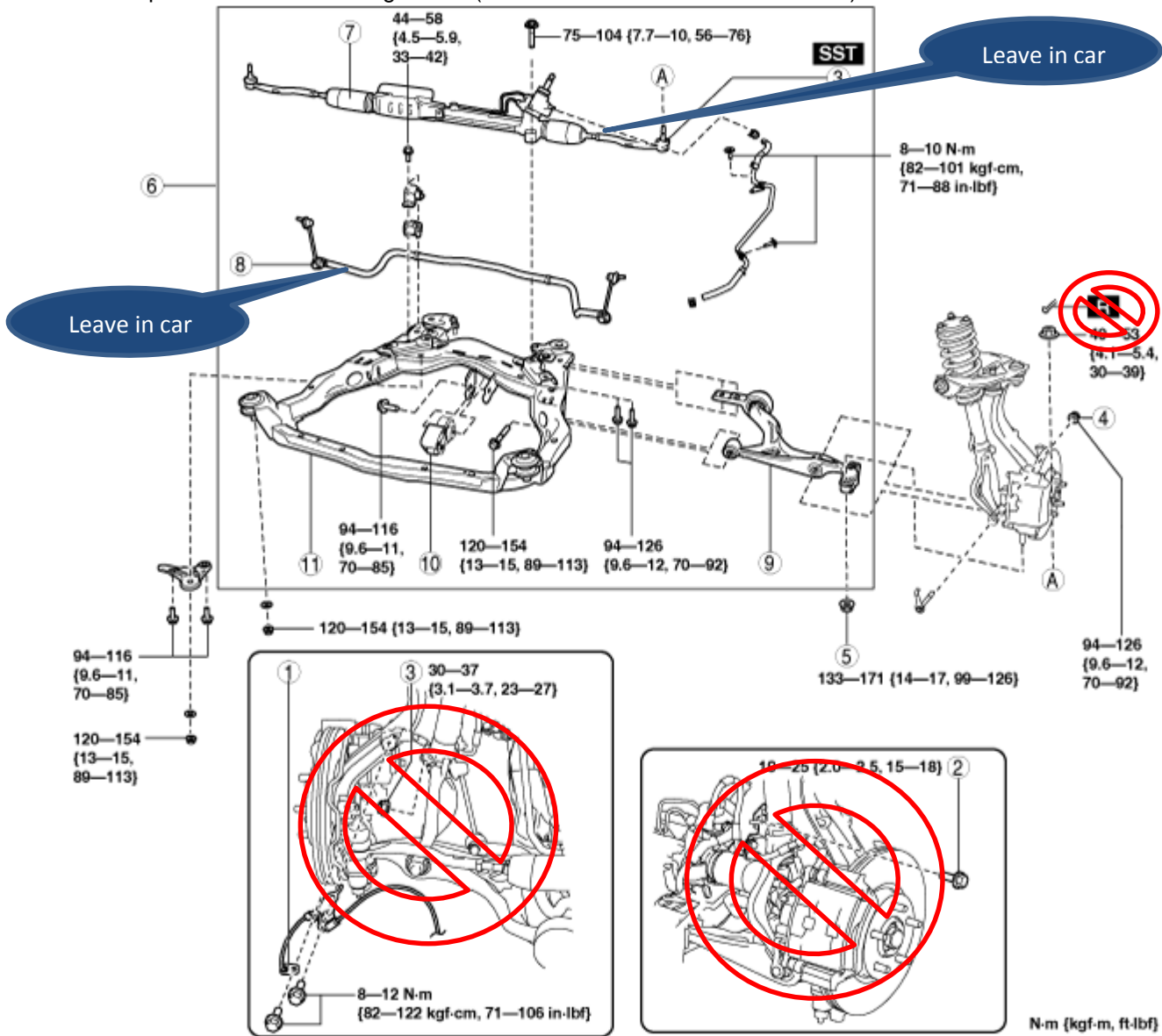

1	Front ABS wheel-speed sensor <i>Not needed with this procedure</i>
2	Brake hose bracket bolt <i>Not needed with this procedure</i>
3	Tie-rod end (See Tie-rod End Removal Note.) <i>Not needed with this procedure</i>
4	Front shock absorber lower side nut
5	Front lower arm outer side nut (See Front Lower Arm Outer Side Nut Removal Note.)
6	Front cross member component (See Front Cross member Component Removal Note.) (See Front Cross member Component Installation Note.)
7	Steering gear and linkage – <i>Remove steering rack bolts x3</i>
8	Front stabilizer – <i>Remove center bracket bolts x4</i>
9	Front lower arm – <i>Remove inner arm bolts after Front Cross Member has been removed then remove Front lower arm and transfer to new Cross member</i>
10	No. 1 engine mount (See No.1 Engine Mount Installation Note.)
11	Front cross member

Front Lower Arm Outer Side Nut Removal Note

Warning

- If the stud bolt of the front knuckle is loosened when removing the front lower arm outer nut, replace the stud bolt with a new one. If the stud bolt is reused, it could fall off while driving, resulting in serious injury or death, and damage to the vehicle.

Front Cross member Component Removal Note

Warning

- Removing the cross member is dangerous. The cross member component could fall and cause serious injury or death. Verify that the jack securely supports the cross member component before removing the cross member bracket.

1. Remove the front lower arm bolts shown in the figure.

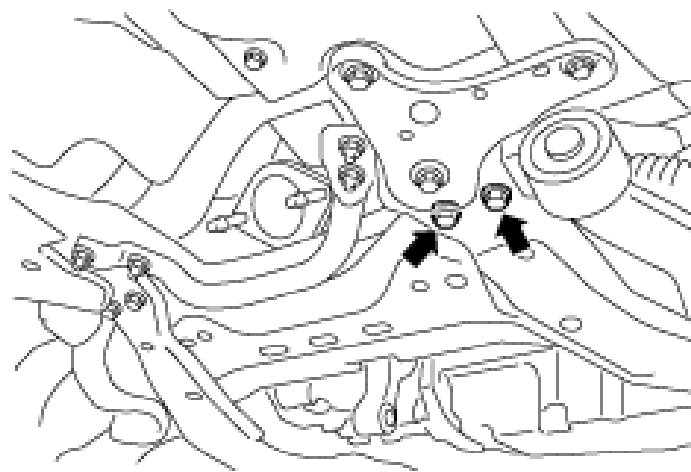

2. Support the cross member component with a jack.

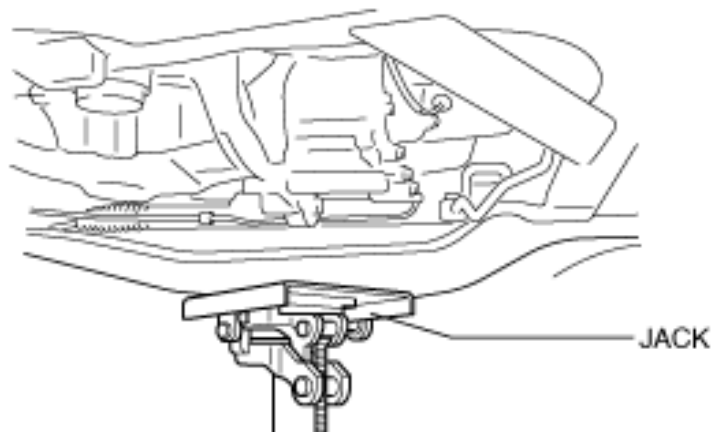

3. Loosen the No.1 engine mount bolts A, and remove the No.1 engine mount bolt B.

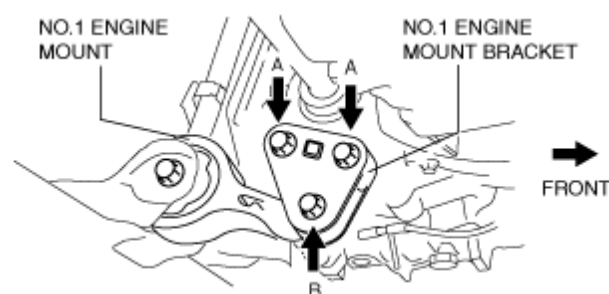

5. Remove the cross member bracket.
6. Remove the front cross member component.

No.1 Engine Mount Installation Note

1. Install the No.1 engine mount to the front cross member and temporarily tighten the bolt until approx. three threads are visible.

Front Cross member Component Installation Note

Warning

· The cross member component could fall and cause serious injury or death. Verify that the jack securely supports the cross member component.

1. Jack up the front cross member component slowly.

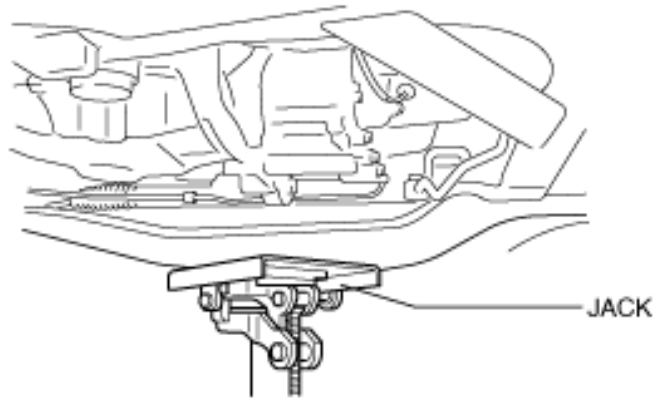

2. Install the front cross member component, and hand tighten the nuts and bolts. Make sure the rear portion of the front cross member is still lowered about 1 inch to access the rack bolts and the sway bar bracket bolts.
3. Install the steering rack bolts x3 and the Sway bar center bracket bolts x4.
4. Tighten steering rack bolts to the proper torque
Tightening torque
75—104 N·m {7.7—10 kgf·m, 56—76 ft·lbf}
5. Tighten sway bar center bracket bolts to the proper torque
Tightening torque
33-42 N·m {4.5—5.9 kgf·m, 33—42 ft·lbf}
6. Tighten the front cross member bolts and nuts to the specified torque.
7. Temporarily tighten the No.1 engine mount bolts A and B.

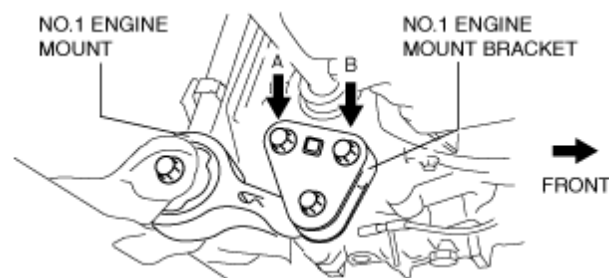

8. Tighten the No.1 engine mount bolts in the order of B and A.
Tightening torque
· 77—103 N·m {7.9—10 kgf·m, 57—75 ft·lbf}

9. Tighten the No.1 engine mount bolt C.

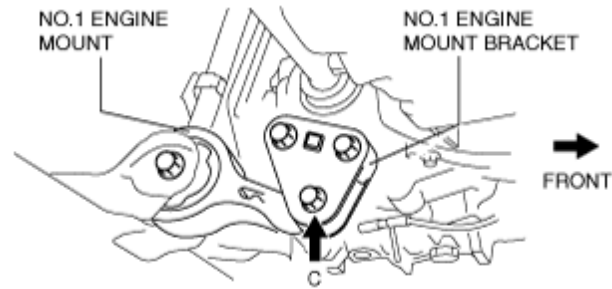

Tightening torque

· 77—103 N·m {7.9—10 kgf·m, 57—75 ft·lbf}

10. Tighten the No.1 engine mount bolt D.

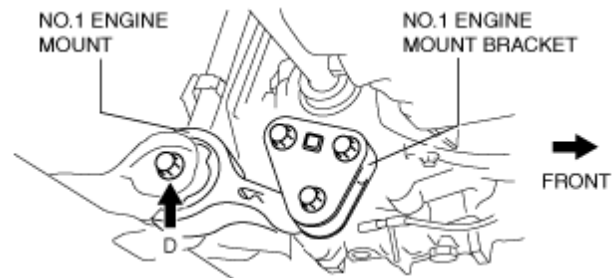

Tightening torque

· 94—116 N·m {9.6—11 kgf·m, 70—85 ft·lbf}

FRONT WHEEL ALIGNMENT

Specification (Unloaded)*1

Front wheel alignment

Item		Specification				
Fuel gauge indication		Empty	1/4	1/2	3/4	Full
Maximum steering angle [Tolerance $\pm 3^\circ$]	Inner	38°54'				
	Outer	32°36'				
Total toe-in	(mm {IN})	Tire: 2±4 {0.08±0.16}, Rim inner: 1±3 {0.04±0.12}				
	(degree)	0°10'±20'				
Caster angle *2 (Reference value) [Tolerance $\pm 1^\circ$]	L5	3°37'	3°38'	3°39'	3°41'	3°42'
	MZI-3.7	3°34'	3°35'	3°37'	3°38'	3°40'
Camber angle *2 (Reference value) [Tolerance $\pm 1^\circ$]	L5	-0°09'	-0°10'	-0°12'	-0°13'	-0°15'
	MZI-3.7	-0°10'	-0°11'		-0°14'	-0°16'
Steering axis inclination (Reference value) [Tolerance $\pm 1^\circ$]	L5	6°31'	6°32'	6°34'	6°36'	6°37'
	MZI-3.7	6°32'	6°33'		6°38'	

*1: Engine coolant and engine oil are at specified level. Spare tire, jack and tools are in designated position.

*2: Difference between left and right must not exceed 1°30'.