

NUMBER: 5.84.17.001.01**DATE: February 2017****MODEL: Model Year 2012 Fisker Karma****Revised: September 2017****TITLE: Remedy - Takata Front Passenger Airbag Inflator Module****PRIORITY:** All Vehicles in Operation**APPLICABILITY:** ALL**MARKET REGIONS:** ALL**PURPOSE:** This document highlights the removal of the recalled Takata Airbag and installation of the new provided part.

This document supersedes any and all previous documents relating to the names and locations in workshop manuals, wiring diagrams, training documents, parts catalog, labor operations, etc.

Safety Recall Notice (Remedy)
2012 Model Year Fisker Karma – Front Passenger Airbag Inflator Module
Important Information Enclosed

The removal process is recreated here in detail. The service manual for 2012 Fisker Karma can be referenced for a guide. This section is found on page 366 of the Service Manual PDF, section 84-10. The service manual instructions guides the technician to remove the dash board. Removal of the entire dashboard assembly is not necessary. With the proper tools, the dash topper panel can be removed without damage, and the airbag readily accessed for replacement, this is found as directed in the manual on page 322 of the PDF, section 80-8.

Have a camera available and ready. Capture images of the removed airbag unit and the new airbag. These images showing both serial numbers (clearly and readable) must be attached to the recall warranty claim, the TSS case and retained with repair order documentation as well, this is needed for the NHTSA recall records.

NUMBER: 5.84.17.001.01

DATE: February 2017

MODEL: Model Year 2012 Fisker Karma

Revised: September 2017

TITLE: Remedy - Takata Front Passenger Airbag Inflator Module

TOOLS REQUIRED:

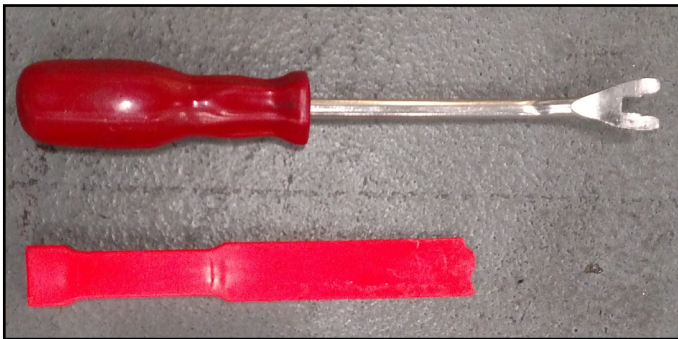

Panel tool and plastic 'bone' tool



10mm socket



13 mm socket



1/4 inch ratchet & 1/4 inch extension (5 in.)



T25 torx bit



90° offset bit driver *or* 90° angle Philips tip



Camera or image capturing device such as a camera equipped mobile phone

Karma Automotive Bulletins and service documents are intended for use by experienced and trained Technicians. If you lack the skills, tools, equipment and a suitable workshop for any procedure described in this document, we suggest you leave such repairs to an Authorized Karma Service Provider or qualified service center. See your service provider for advice on whether your vehicle may benefit from the information contained within this document. The information contained in the Karma Bulletin is accurate at the date of publication. However, Karma Automotive regularly updates technical information. Please check with your Karma Automotive Service Provider that the bulletin you intend to use contains the latest available information.

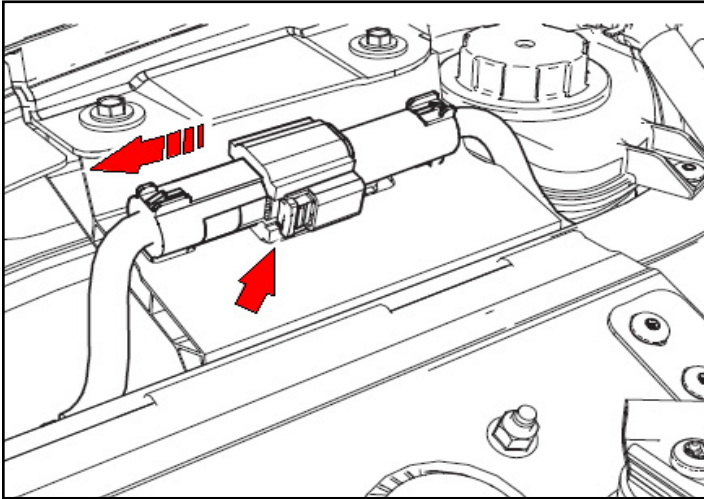
NUMBER: 5.84.17.001.01**DATE: February 2017****MODEL: Model Year 2012 Fisker Karma****Revised: September 2017****TITLE: Remedy - Takata Front Passenger Airbag Inflator Module**

Open hood and both front doors as preparation for the procedure. Disconnect the 12 V battery cable as shown: (located on the passenger hand strut tower).



Enter the car to begin disassembly.

Karma Automotive Bulletins and service documents are intended for use by experienced and trained Technicians. If you lack the skills, tools, equipment and a suitable workshop for any procedure described in this document, we suggest you leave such repairs to an Authorized Karma Service Provider or qualified service center. See your service provider for advice on whether your vehicle may benefit from the information contained within this document. The information contained in the Karma Bulletin is accurate at the date of publication. However, Karma Automotive regularly updates technical information. Please check with your Karma Automotive Service Provider that the bulletin you intend to use contains the latest available information.

NUMBER: 5.84.17.001.01**DATE: February 2017****MODEL: Model Year 2012 Fisker Karma****Revised: September 2017****TITLE: Remedy - Takata Front Passenger Airbag Inflator Module**

Fig.1

Remove the center console jewel trim piece by pulling forward, unplug the connectors, mark their locations with the switch as the center and one outer plug are interchangeable (Fig.1).



Fig.2a

Open the glove box and Remove side console trim around glove box. Pull firmly towards you to release clips, use the bone tool for assistance. (Fig.2a and b).

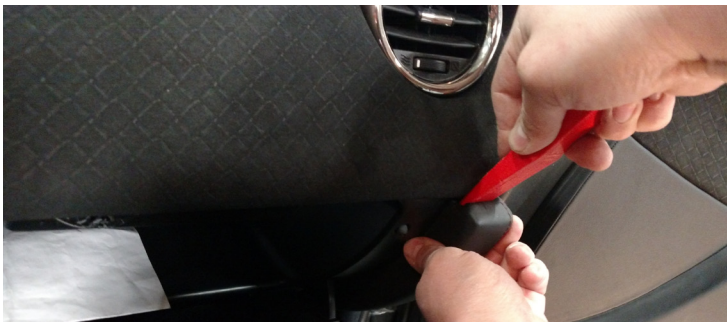

Fig.2b

Karma Automotive Bulletins and service documents are intended for use by experienced and trained Technicians. If you lack the skills, tools, equipment and a suitable workshop for any procedure described in this document, we suggest you leave such repairs to an Authorized Karma Service Provider or qualified service center. See your service provider for advice on whether your vehicle may benefit from the information contained within this document. The information contained in the Karma Bulletin is accurate at the date of publication. However, Karma Automotive regularly updates technical information. Please check with your Karma Automotive Service Provider that the bulletin you intend to use contains the latest available information.

NUMBER: 5.84.17.001.01**DATE: February 2017****MODEL: Model Year 2012 Fisker Karma****Revised: September 2017****TITLE: Remedy - Takata Front Passenger Airbag Inflator Module**

Remove the dash board cover piece. Pull out from clips firmly, use the bone tool for assistance (Fig 3a and 3b).



Fig.3a



Fig. 3b Shown with cover piece removed

Remove the gauge cluster cover panels as shown (Fig. 4a and 4b).



Fig.4a



Fig.4b Shown with cover panel removed

Karma Automotive Bulletins and service documents are intended for use by experienced and trained Technicians. If you lack the skills, tools, equipment and a suitable workshop for any procedure described in this document, we suggest you leave such repairs to an Authorized Karma Service Provider or qualified service center. See your service provider for advice on whether your vehicle may benefit from the information contained within this document. The information contained in the Karma Bulletin is accurate at the date of publication. However, Karma Automotive regularly updates technical information. Please check with your Karma Automotive Service Provider that the bulletin you intend to use contains the latest available information.

NUMBER: 5.84.17.001.01

DATE: February 2017

MODEL: Model Year 2012 Fisker Karma

Revised: September 2017

TITLE: Remedy - Takata Front Passenger Airbag Inflator Module

With the glove box bolts now exposed, use the T25 torx bit undo the fasteners (7) securing glove box to the dash panel and remove the glove box (10Nm torque) (Fig. 5a and Fig. 5b).

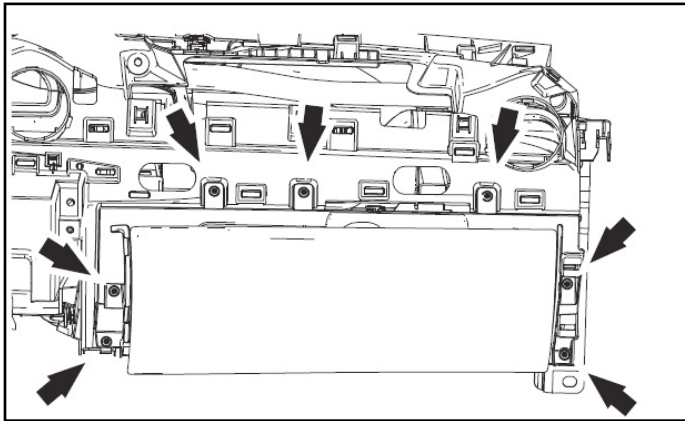

Fig. 5a

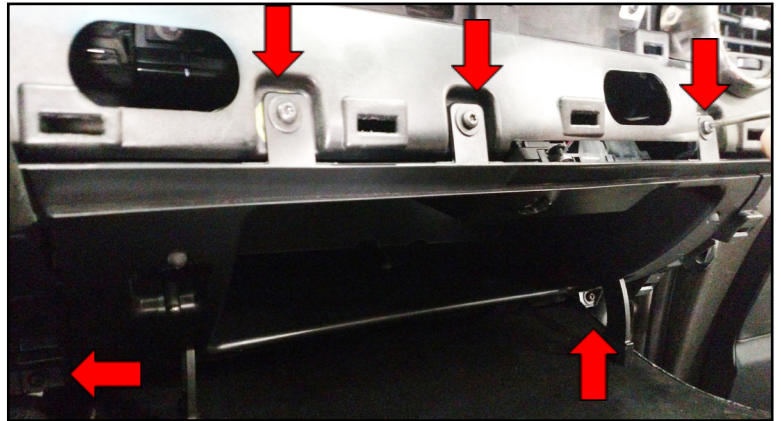

Fig. 5b



Fig. 6

Unplug glove box connectors (Fig. 6).

The air bag lower bolts are now visible (Fig. 7a and 7b).

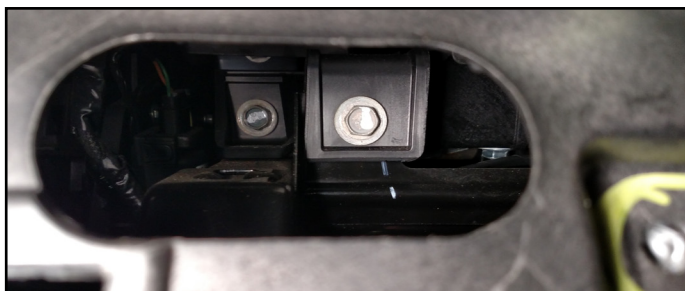

Fig. 7a

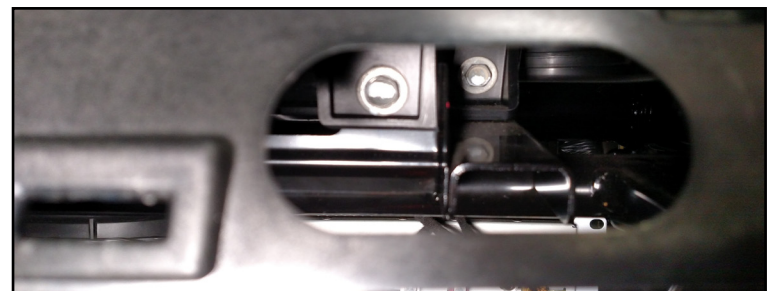

Fig. 7b

Karma Automotive Bulletins and service documents are intended for use by experienced and trained Technicians. If you lack the skills, tools, equipment and a suitable workshop for any procedure described in this document, we suggest you leave such repairs to an Authorized Karma Service Provider or qualified service center. See your service provider for advice on whether your vehicle may benefit from the information contained within this document. The information contained in the Karma Bulletin is accurate at the date of publication. However, Karma Automotive regularly updates technical information. Please check with your Karma Automotive Service Provider that the bulletin you intend to use contains the latest available information.

NUMBER: 5.84.17.001.01

DATE: February 2017

MODEL: Model Year 2012 Fisker Karma

Revised: September 2017

TITLE: Remedy - Takata Front Passenger Airbag Inflator Module

Disconnect the airbag harness clip and the airbag connector (Fig 8a and 8b).

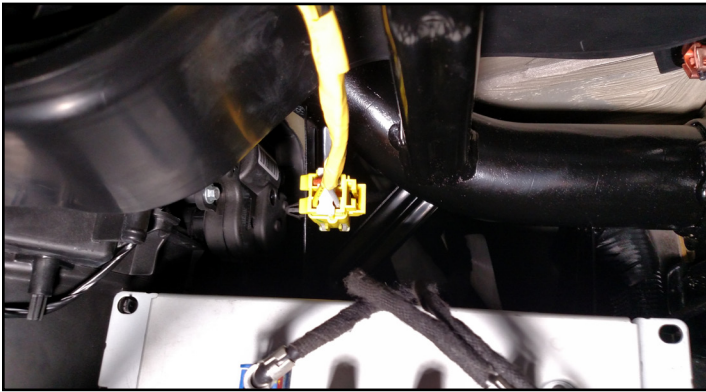

Fig. 8a

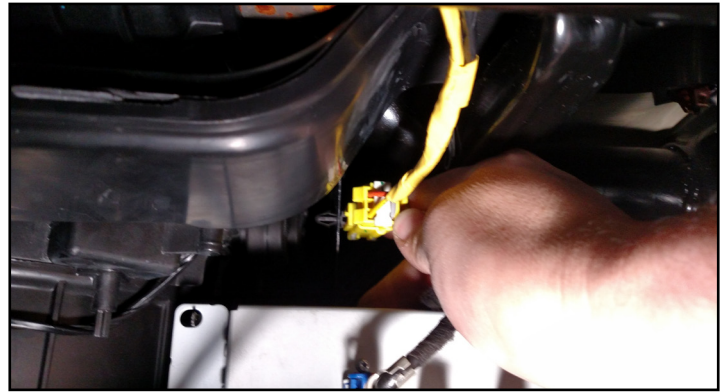

Fig. 8b

Remove the a-pillar trim. Remember to remove the Tether clip from the top portion by sliding it out of the A-pillar. Remove the A-pillar. Remember to remove the tether clip from the top portion by sliding it out of the A-pillar (Fig.9a and 9b).



Fig. 9a



Fig. 9b

Note the tweeter plugs, disconnect and remove.

Note: Take careful action to remove all trim pieces to avoid damage, pull out the left and right dash.

Karma Automotive Bulletins and service documents are intended for use by experienced and trained Technicians. If you lack the skills, tools, equipment and a suitable workshop for any procedure described in this document, we suggest you leave such repairs to an Authorized Karma Service Provider or qualified service center. See your service provider for advice on whether your vehicle may benefit from the information contained within this document. The information contained in the Karma Bulletin is accurate at the date of publication. However, Karma Automotive regularly updates technical information. Please check with your Karma Automotive Service Provider that the bulletin you intend to use contains the latest available information.

NUMBER: 5.84.17.001.01**DATE: February 2017****MODEL: Model Year 2012 Fisker Karma****Revised: September 2017****TITLE: Remedy - Takata Front Passenger Airbag Inflator Module**

Fig. 10

pillar trim pieces. Pull firmly straight out to release from clips (Fig. 10).

Remove the dash pad finisher. Lift up gently using the plastic bone panel tool for assistance (Fig. 11a and 11b) This will expose the dash pad fasteners (Fig. 11c).



Fig. 11a



Fig. 11b



Fig. 11c

Karma Automotive Bulletins and service documents are intended for use by experienced and trained Technicians. If you lack the skills, tools, equipment and a suitable workshop for any procedure described in this document, we suggest you leave such repairs to an Authorized Karma Service Provider or qualified service center. See your service provider for advice on whether your vehicle may benefit from the information contained within this document. The information contained in the Karma Bulletin is accurate at the date of publication. However, Karma Automotive regularly updates technical information. Please check with your Karma Automotive Service Provider that the bulletin you intend to use contains the latest available information.

NUMBER: 5.84.17.001.01

DATE: February 2017

MODEL: Model Year 2012 Fisker Karma

Revised: September 2017

TITLE: Remedy - Takata Front Passenger Airbag Inflator Module

Use the 90 degree bit driver, remove the dash-pad bolts (16) (Indicated by red arrows - Fig. 12a and 12 b). Install torque 10Nm

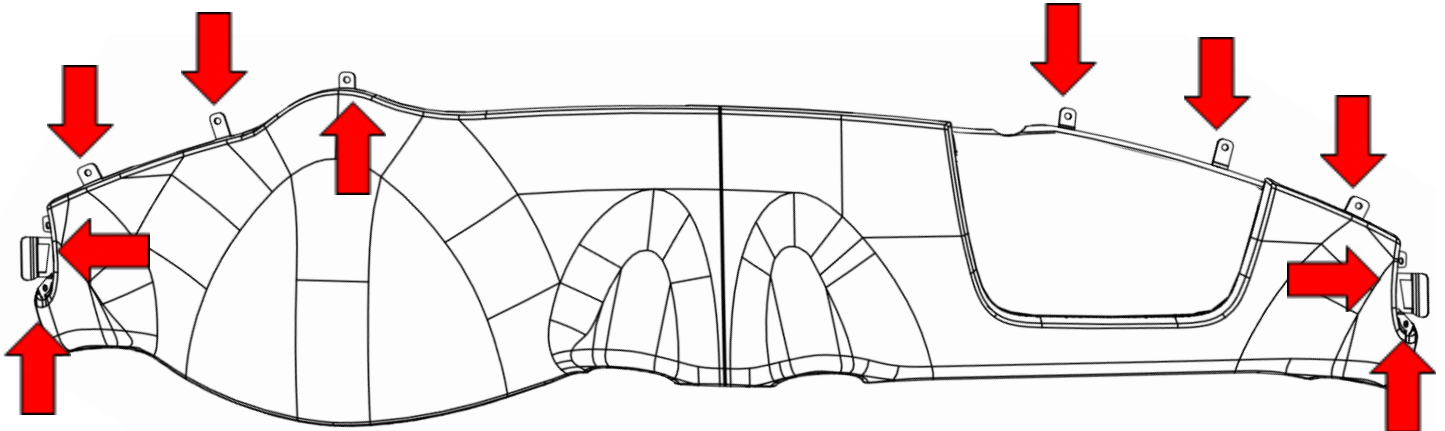

Fig. 12a

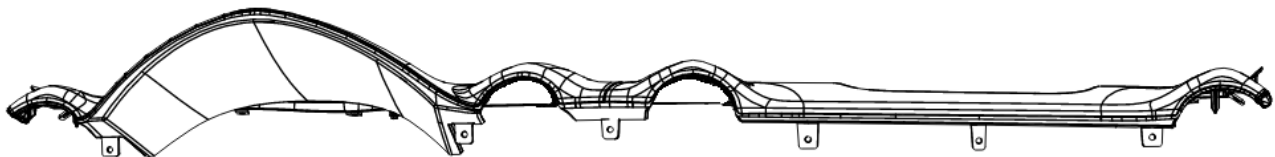

Fig. 12b

Use of the 90°
bit driver
Fig. 13a and 13b



Fig. 13a

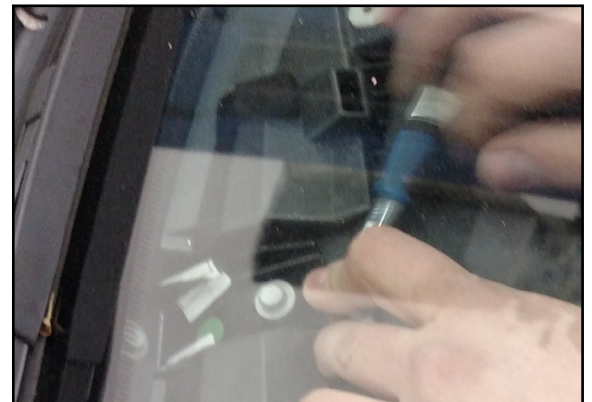

Fig. 13b

Karma Automotive Bulletins and service documents are intended for use by experienced and trained Technicians. If you lack the skills, tools, equipment and a suitable workshop for any procedure described in this document, we suggest you leave such repairs to an Authorized Karma Service Provider or qualified service center. See your service provider for advice on whether your vehicle may benefit from the information contained within this document. The information contained in the Karma Bulletin is accurate at the date of publication. However, Karma Automotive regularly updates technical information. Please check with your Karma Automotive Service Provider that the bulletin you intend to use contains the latest available information.

NUMBER: 5.84.17.001.01

DATE: February 2017

MODEL: Model Year 2012 Fisker Karma

Revised: September 2017

TITLE: Remedy - Takata Front Passenger Airbag Inflator Module

Note the Fasteners found on the front face of the dash pad (Fig. 14a and 14b).



Fig. 14a



Fig. 14b



Fig. 15

A “hidden” fastener on the A-Pillar location of the dash panel (Fig. 15).

The daylight sensor is connected to the center portion of the dash pad base, this can be removed by turning it ninety degrees (90°) in the housing it will slide out without needing to undo the two stage connector on the harness side (Fig. 16a,16b, and 16c).

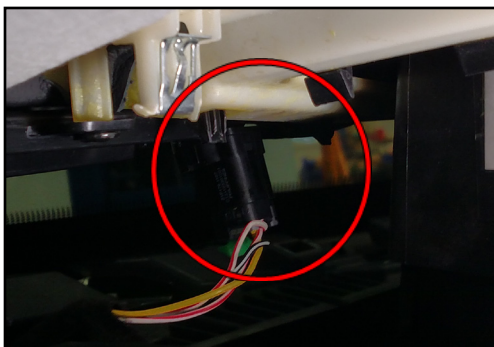

Fig. 16a



Fig. 16b



Fig. 16c

Karma Automotive Bulletins and service documents are intended for use by experienced and trained Technicians. If you lack the skills, tools, equipment and a suitable workshop for any procedure described in this document, we suggest you leave such repairs to an Authorized Karma Service Provider or qualified service center. See your service provider for advice on whether your vehicle may benefit from the information contained within this document. The information contained in the Karma Bulletin is accurate at the date of publication. However, Karma Automotive regularly updates technical information. Please check with your Karma Automotive Service Provider that the bulletin you intend to use contains the latest available information.

NUMBER: 5.84.17.001.01

DATE: February 2017

MODEL: Model Year 2012 Fisker Karma

Revised: September 2017

TITLE: Remedy - Takata Front Passenger Airbag Inflator Module



Fig. 17a

Remove the dash pad, and turn over. Place on a safe fabric covered surface to avoid damage to the dash pad surface (Fig. 17a and 17b).

The airbag is located and secured by clips on the dash pad, release the clips (3) for the harness.

Set aside the recalled Takata air bag assembly. (Fig. 18a and 18b)



Fig. 17b



WARNING

Store the airbag module with the deployment side facing up. This will prevent it from being propelled if accidentally deployed which may cause injury.

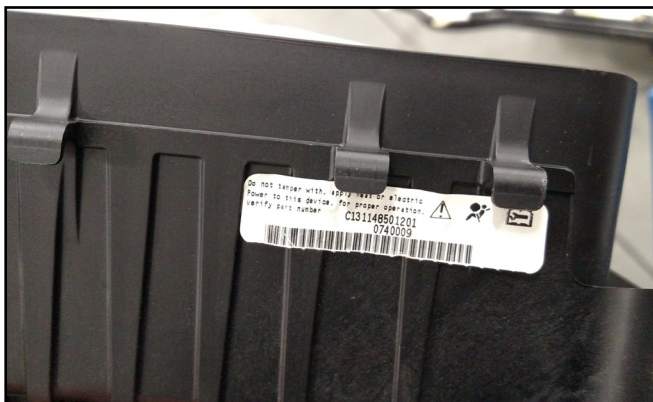

Fig. 18a

Part number and serial number visible.

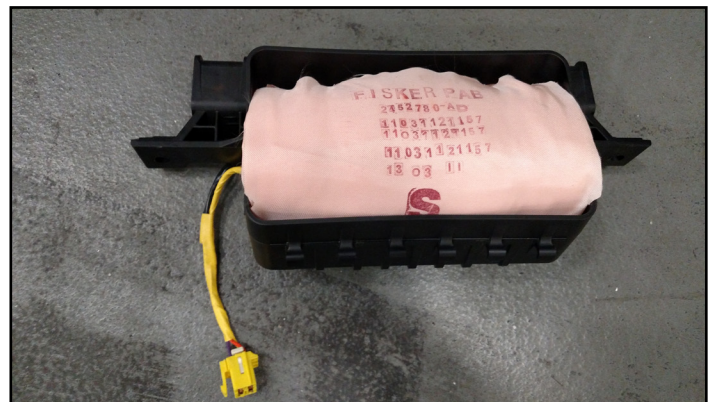

Fig. 18b

The recalled air bag unit when removed, notice the "Fisker PAB" printed label.

Karma Automotive Bulletins and service documents are intended for use by experienced and trained Technicians. If you lack the skills, tools, equipment and a suitable workshop for any procedure described in this document, we suggest you leave such repairs to an Authorized Karma Service Provider or qualified service center. See your service provider for advice on whether your vehicle may benefit from the information contained within this document. The information contained in the Karma Bulletin is accurate at the date of publication. However, Karma Automotive regularly updates technical information. Please check with your Karma Automotive Service Provider that the bulletin you intend to use contains the latest available information.

NUMBER: 5.84.17.001.01

DATE: February 2017

MODEL: Model Year 2012 Fisker Karma

Revised: September 2017

TITLE: Remedy - Takata Front Passenger Airbag Inflator Module

KARMA AUTOMOTIVE, LLC

Campaign No.: _____

Description: _____

Retailer Code: _____

Repair Date: ____ / ____ / ____

For questions, please contact
Client Services at 1-855-565-2762
C149950001100

Fig. 19

Follow the instructions provided with the Takata airbag to return the air bag to the manufacturer.

Install the new part C131148501303 provided with the kit C161148300100.

Fasten to the dash pad assembly
Installation of the dash pad is the reverse of disassembly.

Please apply label (Fig.19) to the location indicated on the passenger side shock tower (Fig. 20). This will indicate the recall has been performed and is required to ensure compliance with the Takata Airbag recall.



Fig. 20

Please retain photographs of the removed airbag *and* the new airbag for repair documentation as well, the serial number of both airbags should be clearly visible and readable in the images. As mentioned previously, images must also be attached to the recall claim, the TSS case and retained with repair order documentation as well.

Karma Automotive Bulletins and service documents are intended for use by experienced and trained Technicians. If you lack the skills, tools, equipment and a suitable workshop for any procedure described in this document, we suggest you leave such repairs to an Authorized Karma Service Provider or qualified service center. See your service provider for advice on whether your vehicle may benefit from the information contained within this document. The information contained in the Karma Bulletin is accurate at the date of publication. However, Karma Automotive regularly updates technical information. Please check with your Karma Automotive Service Provider that the bulletin you intend to use contains the latest available information.

NUMBER: 5.84.17.001.01

DATE: February 2017

MODEL: Model Year 2012 Fisker Karma

Revised: September 2017

TITLE: Remedy - Takata Front Passenger Airbag Inflator Module

PARTS REQUIRED:

PART NUMBER	DESCRIPTION
C161148300100	Passenger Airbag Module Assembly (without door) - Service Kit

SHOP SUPPLIES:

DESCRIPTION
N/A

SPECIAL TOOLS:

DESCRIPTION
N/A

LABOR CODES:

CODE	DESCRIPTION	TIME	DEFECT CODE
RC-00-00-01	Recall 58417001 Takata Airbag Inflator / Repair	3.5	84-20-05-33

SUBLET:

CODE	DESCRIPTION	AMOUNT
N/A		

CAUSAL PART:

PART NUMBER	DESCRIPTION
C131148501300	Air Bag Module- Passenger (Without door)

WARRANTY DISPOSITION:

The claim cannot be processed without full compliance of this bulletin. Ensure the following have been performed:

- The new unit has been installed correctly into the vehicle
- The recalled airbag unit has been repackaged for shipment back to the manufacturer
- Campaign Label has been applied to the proper location
- Images and repair order have been attached to the warranty claim and submitted to Karma Automotive LLC

Karma Automotive Bulletins and service documents are intended for use by experienced and trained Technicians. If you lack the skills, tools, equipment and a suitable workshop for any procedure described in this document, we suggest you leave such repairs to an Authorized Karma Service Provider or qualified service center. See your service provider for advice on whether your vehicle may benefit from the information contained within this document. The information contained in the Karma Bulletin is accurate at the date of publication. However, Karma Automotive regularly updates technical information. Please check with your Karma Automotive Service Provider that the bulletin you intend to use contains the latest available information.

NUMBER: 5.84.17.001.01**DATE: February 2017****MODEL: Model Year 2012 Fisker Karma****Revised: September 2017****TITLE: Remedy - Takata Front Passenger Airbag Inflator Module**

For Reference: The Shipping instructions provided by Takata are shown here. These will be included in the passenger airbag kit (C161148300100) shipped to the service center.

48 STATE FEDEX GROUND SHIPMENT PREPARATION

As the shipper, you are responsible for proper packing and document completion. The person packaging the inflator must have received hazardous material training per 49CFR 172.702, and the training records must be on file at your dealership. The US Department of Transportation will impose substantial fines and/or penalties on the shipper if either packaging, labeling or documentation is not properly prepared and Customer Copy of OP 900PRP form is not kept on file for a minimum of 2 years.

IMPORTANT: Do not deploy any inflator. Return the used inflator within 1-2 business days. The person packing the used inflator must read and follow the provided instructions.

NOTE: Dealers in Hawaii, Puerto Rico, and US Virgin Islands CANNOT follow these shipping instructions. The dealer MUST contact the following Takata USA representative directly for shipping instructions: Miguel Prigadaa – Tel #: 210-250-5078 or Email: SCFieldAction.14305@xpo.com

Shipper Receipt 5004282 07211275	Receipt 5004282 07211275	Shipper Number 5004282
FedEx Ground® Package Returns Program		
From:		
Address		
City		
State/Prov.		
ZIP/Postal		
RMA#		
Turn Over for Instructions		
HAZMAT		
Ship To:		
TK HOLDINGS INC		
1199 Austin Court		
Howell, MI 48843		
		
		
(9612300) 5004282 07211275		

FedEx Ground Shipping Label for the return of the defective part.

Karma Automotive Bulletins and service documents are intended for use by experienced and trained Technicians. If you lack the skills, tools, equipment and a suitable workshop for any procedure described in this document, we suggest you leave such repairs to an Authorized Karma Service Provider or qualified service center. See your service provider for advice on whether your vehicle may benefit from the information contained within this document. The information contained in the Karma Bulletin is accurate at the date of publication. However, Karma Automotive regularly updates technical information. Please check with your Karma Automotive Service Provider that the bulletin you intend to use contains the latest available information.

NUMBER: 5.84.17.001.01

DATE: February 2017

MODEL: Model Year 2012 Fisker Karma

Revised: September 2017

TITLE: Remedy - Takata Front Passenger Airbag Inflator Module

**1.) Shipping Documents:
OP 900PRP Hazardous Materials Certification Form**

FEED FROM THIS END

Package Return Program - Hazardous Materials Certification

Number and Type Packaging	UNID	DOT Shipping Name of Material	UN Classification Code	Weight	Label Type/Other Information
1 DHD	UN3268	Safety Devices	Class 9	3 lbs.	Class 9

Shipper Information:
 Name: TK Holdings CCN21726
 Account #: 7154379
 Emergency Contact Number: 1-800-424-9300

Recipient Information:
 Name: TK Holdings CCN21726
 Account #: 7154379
 Emergency Contact Number: 1-800-424-9300

Signature: Harry Glen Pardon

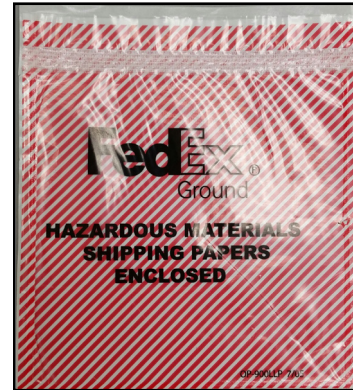

FedEx Ground Shipping Envelope

2. Packing Instructions

- a) Confirm box is in acceptable condition. If a new box is needed, follow the New Box instructions located on the next page.
- b) Place the un-deployed air bag module in the “cradle” of the box insert.



Karma Automotive Bulletins and service documents are intended for use by experienced and trained Technicians. If you lack the skills, tools, equipment and a suitable workshop for any procedure described in this document, we suggest you leave such repairs to an Authorized Karma Service Provider or qualified service center. See your service provider for advice on whether your vehicle may benefit from the information contained within this document. The information contained in the Karma Bulletin is accurate at the date of publication. However, Karma Automotive regularly updates technical information. Please check with your Karma Automotive Service Provider that the bulletin you intend to use contains the latest available information.

NUMBER: 5.84.17.001.01

DATE: February 2017

MODEL: Model Year 2012 Fisker Karma

Revised: September 2017

TITLE: Remedy - Takata Front Passenger Airbag Inflator Module

3. Closure Instructions

a) Close the top box flap, per box closure instructions located on front panel of box.



4. Shipping Documentation Instructions

a) Separate the bottom 4 labels (OP 900PRP form), place them in the FedEx Ground envelope, remove the backing and firmly place on bottom side of box.



b) Peel off the Box Copy of the OP 900PRP form and firmly apply to the top side of the box.

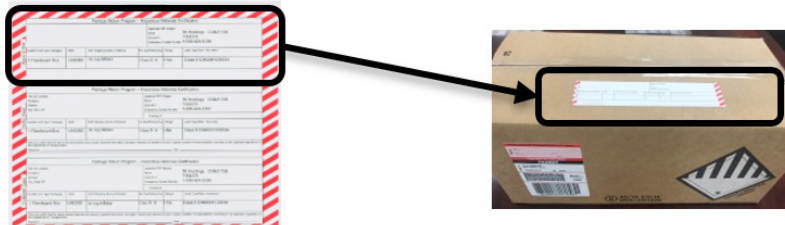

Karma Automotive Bulletins and service documents are intended for use by experienced and trained Technicians. If you lack the skills, tools, equipment and a suitable workshop for any procedure described in this document, we suggest you leave such repairs to an Authorized Karma Service Provider or qualified service center. See your service provider for advice on whether your vehicle may benefit from the information contained within this document. The information contained in the Karma Bulletin is accurate at the date of publication. However, Karma Automotive regularly updates technical information. Please check with your Karma Automotive Service Provider that the bulletin you intend to use contains the latest available information.

NUMBER: 5.84.17.001.01

DATE: February 2017

MODEL: Model Year 2012 Fisker Karma

Revised: September 2017

TITLE: Remedy - Takata Front Passenger Airbag Inflator Module

5. Shipping Documentation Instructions (Cont.)

a) Fill in the following on the FedEx Copy and the customer copy:

- Shipper Name (dealer)
- Address
- CCN

1)

b) Date the FedEx Copy and Customer copy (MM/DD/YY)

2)

6. Shipping Documentation Instructions (Cont.)

a) Peel off the SHIPPER RECEIPT from the top of the FedEx Ground PRP Shipping label, place it in the Tracking ID box on the Customer Copy of the OP 900PRP form. 3)

b) Peel off the RECEIPT & SHIPPER NUMBER from the top of the FedEx Ground PRP Shipping label, and place it in the Tracking ID box on the FedEx copy. 4)

Karma Automotive Bulletins and service documents are intended for use by experienced and trained Technicians. If you lack the skills, tools, equipment and a suitable workshop for any procedure described in this document, we suggest you leave such repairs to an Authorized Karma Service Provider or qualified service center. See your service provider for advice on whether your vehicle may benefit from the information contained within this document. The information contained in the Karma Bulletin is accurate at the date of publication. However, Karma Automotive regularly updates technical information. Please check with your Karma Automotive Service Provider that the bulletin you intend to use contains the latest available information.

NUMBER: 5.84.17.001.01

DATE: February 2017

MODEL: Model Year 2012 Fisker Karma

Revised: September 2017

TITLE: Remedy - Takata Front Passenger Airbag Inflator Module

7. Shipping Documentation Instructions (Cont.)

a) Separate the FedEx Copy and Customer Copy of the OP 900PRP form. Keep the FedEx copy with the box. Attach the Customer Copy to the Repair Order.

Note: Dealers must retain the Customer Copy of OP 900PRP form in their records for 2 years.

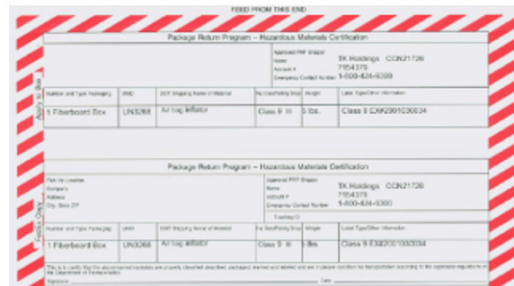

Dealership Copy

8. FedEx Ground PRP Shipping label

a) Fill in Shipper Name & Address in the upper section of the FedEx Ground Shipping label. Note: (RMA# is not required).

b) Peel off the backing of the FedEx Ground PRP Shipping label and affix to top of box to left of the Class 9 label.

- Use the scribe line on the box as a guide
- The FedEx Ground PRP Shipping label must not touch any portion of the printing to the right of the scribe line.

c) Provide the package and the FedEx Copy of The OP 900PRP form to the FedEx Ground Driver.

Note: If you don't receive regular pickups from Fed-Ex, call 800-463-3339 to schedule a pickup of the package.

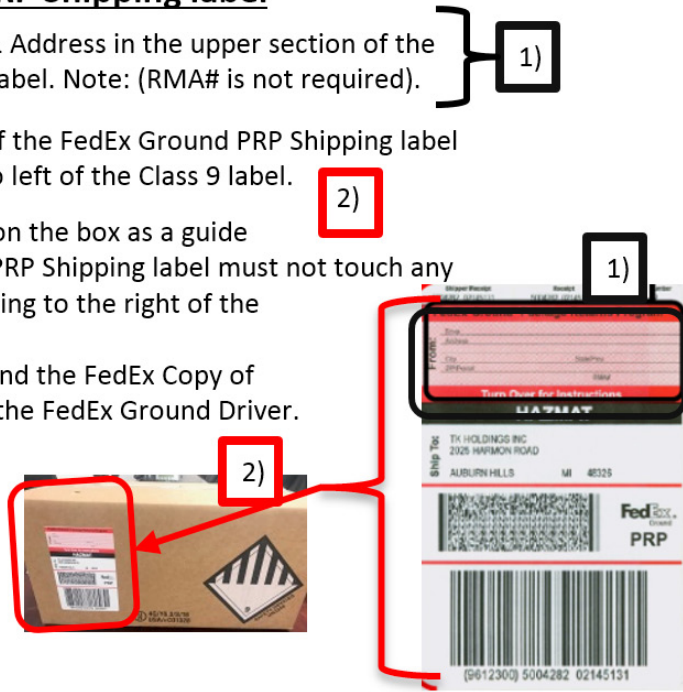

Karma Automotive Bulletins and service documents are intended for use by experienced and trained Technicians. If you lack the skills, tools, equipment and a suitable workshop for any procedure described in this document, we suggest you leave such repairs to an Authorized Karma Service Provider or qualified service center. See your service provider for advice on whether your vehicle may benefit from the information contained within this document. The information contained in the Karma Bulletin is accurate at the date of publication. However, Karma Automotive regularly updates technical information. Please check with your Karma Automotive Service Provider that the bulletin you intend to use contains the latest available information.

NUMBER: 5.84.17.001.01**DATE: February 2017****MODEL: Model Year 2012 Fisker Karma****Revised: September 2017****TITLE: Remedy - Takata Front Passenger Airbag Inflator Module****Requesting a New Box / Shipping Labels**

If a new box or replacement shipping labels are needed, please contact a Takata USA representative listed below by phone or email to request replacement materials.

Primary Contact: **XPO Customer service Rep- Tel #: 210-250-5079**

E-Mail: SCFieldAction.14305@xpo.com

To help expedite your request, please be prepared to provide the following information:

- a) Serial number on the original box
- b) What Type of shipping material needed
 - OP-900prp Hazardous Materials Certification Form
 - FedEx Ground Shipping Label
 - FedEx Ground Shipping Envelope
- c) Dealer Shipping Information
 - Contact name
 - Dealer address
 - Phone Number



End

Karma Automotive Bulletins and service documents are intended for use by experienced and trained Technicians. If you lack the skills, tools, equipment and a suitable workshop for any procedure described in this document, we suggest you leave such repairs to an Authorized Karma Service Provider or qualified service center. See your service provider for advice on whether your vehicle may benefit from the information contained within this document. The information contained in the Karma Bulletin is accurate at the date of publication. However, Karma Automotive regularly updates technical information. Please check with your Karma Automotive Service Provider that the bulletin you intend to use contains the latest available information.