

Field campaign

Topic	Mulsanne - Rear seat belt anchor plate installation (RE19/01)
Market area	Bentley: worldwide (2WBE),Hongkong-Macau (5HK)
Brand	Bentley
Transaction No.	2052868/1
Campaign number	RB15
Note	
Type	
US code	

Vehicle data

Mulsanne - Five seat variant

Sales types

Type	MY	Brand	Designation	Engine code	Gearbox code	Final drive code
3Y2*	2012	E		*	*	*
3Y2*	2013	E		*	*	*
3Y2*	2014	E		*	*	*
3Y2*	2015	E		*	*	*
3Y2*	2016	E		*	*	*
3Y2*	2017	E		*	*	*
3Y2*	2018	E		*	*	*
3Y2*	2019	E		*	*	*

Chassis numbers

Manufacturer	Filler	Type	Filler	MY	Factory	From	To	Prod from	Prod to
SCB	*	3Y	*	C	C	000201	000212		
SCB	*	3Y	*	D	C	000301	000306		
SCB	*	3Y	*	*	C	016890	019941		
SCB	*	ZH	*	*	C	000401	004144		

Documents

Document name
master.xml

Notes

Repair instructions

Technical background

The right and left hand inner rear seat frame studs as shown in Figure 1 are located on opposing sides of the propshaft tunnel, the studs are used to locate and secure the rear seat frames, centre seat belt buckle and the seat belt anchor to the rear floor panel

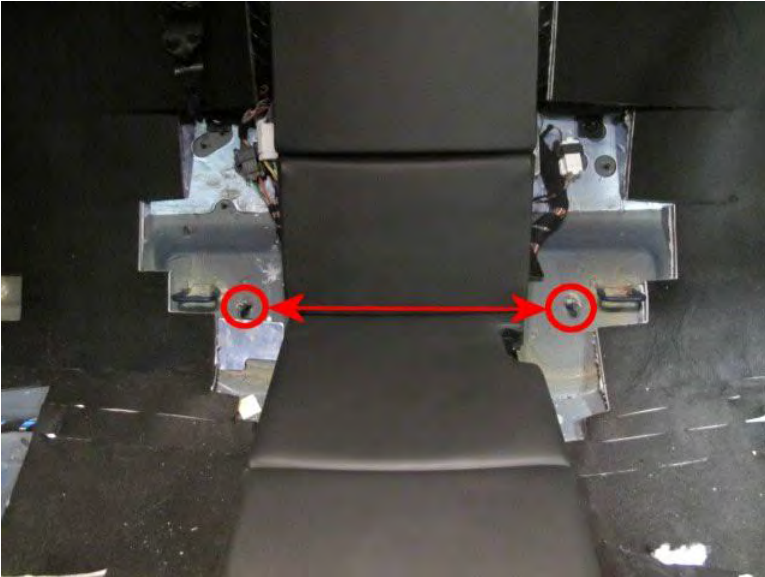

Figure 1

Both studs require removal, once removed the installation of pre-assembled plates is required to the left and right hand side

The remaining rear seat frame securing points and rear seat belt securing points/fixings are not affected

Remedy

The installation of left and right hand plates is required for remedy, the replacement seat frame studs are an integral part of the plates

19 Model Year Vehicles only

Prior to starting the rework procedure a visual confirmation is required to confirm that the rework process has not already been conducted

Carry out the check as follows:

Position the vehicle on a ramp, set the vehicle into "JACK" mode and carry out the usual workshop safety precautions. Refer to Elsa Pro Maintenance section - Raising the vehicle

- Raise the vehicle

Referring to Figure 2, conduct a visual inspection of the rear floor panel using the left and right hand access points shown, the operative should look directly above the front section of the rear subframe, the rework status can be easily identified by the colour of the underseal which is applied

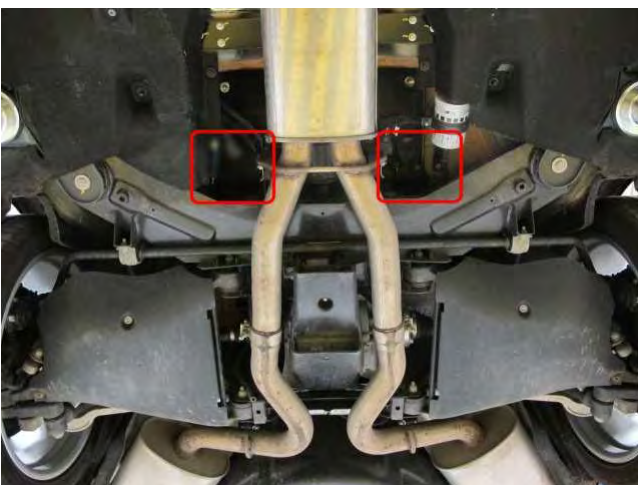

Figure 2

- Referring to Figure 3 - Should light grey underseal be found to be applied to the floor panel on the left and right hand sides, the plates have already been fitted, no further action is required (For clarity Figure 3 shows the left hand side), *please submit a Warranty claim via SAGA for a total of 10 Time units, this will ensure the VIN is removed from the applicability list*

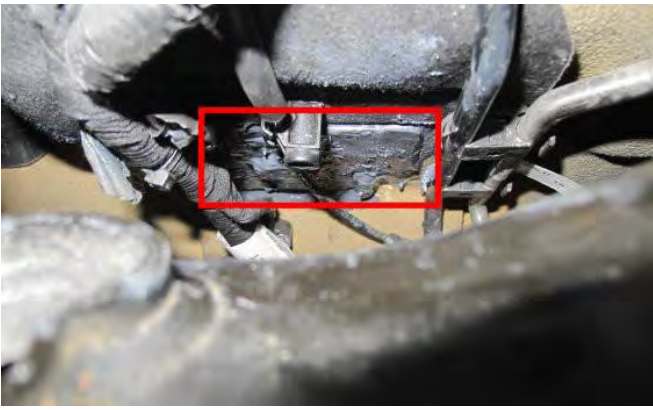

Figure 3

- Referring to Figure 4 - Should the rear floor panel **NOT** have any light grey underseal evident and has the standard beige underseal applied the rework **HAS NOT** been conducted therefore carry out the rework procedure as detailed within this document



Figure 4

Customer notification

Keepers of affected vehicles will be notified in writing by the Bentley retailer.

Please ensure that all affected vehicles are checked and repaired during the next workshop visit, make a note of the required Recall Campaign on the workshop order before it is signed by the customer.

If it is omitted to perform the work required for the Recall Campaign during a workshop visit, the customer should be notified immediately.

You should also pass on this information to your new and used car sales departments so that vehicles affected are checked and if necessary repaired immediately.

Warranty accounting instructions

Warranty type	790 or 710
Labour Operation Code	72 70 42 00
Damage Service Number	RB15
Damage Code	00 99
Time	290 Time units
Criteria ID	01

Genuine parts

Part number	Description	Quantity
3Y5 803 621	Left hand plate	1
3Y5 803 622	Right hand plate	1
3M Scotch-weld DP 490	Epoxy Structural adhesive	Source locally
Forgeway Formoa Seal Bond	Underseal	Source locally

NOTE: Should 3M Scotch-weld DP 490 not be available in your region an equivalent 2-part epoxy adhesive with an approximate working time of 2

hours will be suitable, see below for examples:

- Araldite 2015
- Loctite 9466
- Betamate 2098

NOTE: Should Forgeway Formoa Seal bond not be available in your region an equivalent underbody underseal will be suitable

Parts supply

The required replacement parts should be ordered from Bentley Motors Limited Crewe or through your regional Bentley parts distribution centre

Parts despatch control

Not applicable

Questions and answers

What is the specific issue with the affected vehicles?

During testing in September 2018, it was identified that the rear seat belt anchorage performance may not fulfil the load requirements. This is because the mounting points of the seat belt buckles used had been manufactured by the supplier using an incorrect grade of material.

What repercussions does the fault have?

Although no customers have experienced any related issues, this precautionary measure is because the seat belt anchorages may not fulfil the load requirements if the rear centre seat is occupied at the same time as an outer seat. Therefore, in the event of an impact accident, there is a risk that the rear seat belt buckle may become detached from the body structure.

Which vehicles are affected?

All 5-seat Mulsanne models built between January 2012 and September 2018.

Why does it not affect 4-seat Mulsanne models?

The seat belt anchorage meets the specifications required for the 4-seat configuration.

Can customers continue to drive the cars?

An appointment for the rectification should be made as soon as possible.

What is the fix?

An additional reinforcement plate will be fitted to the body structure to improve the strength of the rear seat belt mounting in the vehicle. This will take approximately three hours.

Do I have to make an appointment?

Yes, that's important. Please contact your retailer immediately.

Repair instructions

• **Notes**

Technical background

The right and left hand inner rear seat frame studs as shown in Figure 1 are located on opposing sides of the propshaft tunnel, the studs are used to locate and secure the rear seat frames, centre seat belt buckle and the seat belt anchor to the rear floor panel

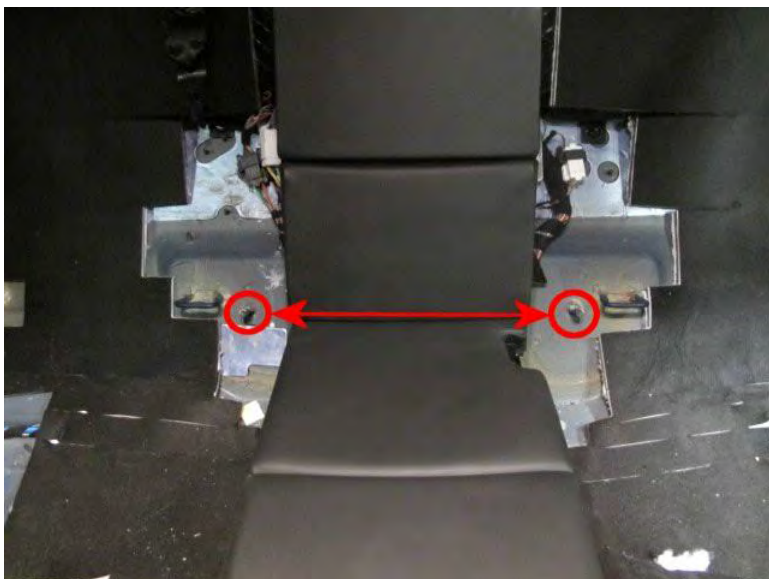

Figure 1

Both studs require removal, once removed the installation of pre-assembled plates is required to the left and right hand side

The remaining rear seat frame securing points and rear seat belt securing points/fixings are not affected

Check

If the vehicle is not already listed as repaired in the "Repair history" (in Elsa Pro) check for the rework completion mark which is a yellow paint mark on the underside of the left hand rear door harness connector (Figure 36) should neither be evident carry out the required work in accordance with

these instructions

Control

All vehicles post SCBBT7ZH1KC004144 are to specification

Only vehicles specified with five seats are affected

Genuine parts

Part number	Description	Quantity
3Y5 803 621	Left hand plate	1
3Y5 803 622	Right hand plate	1
3MScotch-weld DP 490	Epoxy Structural adhesive	Source locally
Forgeway Formoa Seal Bond	Underseal	Source locally

NOTE: Should 3M Scotch-weld DP 490 not be available in your region an equivalent 2-part epoxy adhesive with an approximate working time of 2 hours will be suitable, see below for examples:

- Araldite 2015
- Loctite 9466
- Betamate 2098

NOTE: Should Forgeway Formoa Seal bond not be available in your region an equivalent underbody underseal will be suitable

Tools

WT 10527 - Starrett A1 Arbor

WT 10528 - Starrett 16mm fast cut holesaw

Remove the drill bit from the Arbor by slacking the retaining screw (Figure 5, Point A) remove the drill bit in the direction shown (Point B) once the drill is removed tighten the retaining screw to ensure it does not become loose during operation

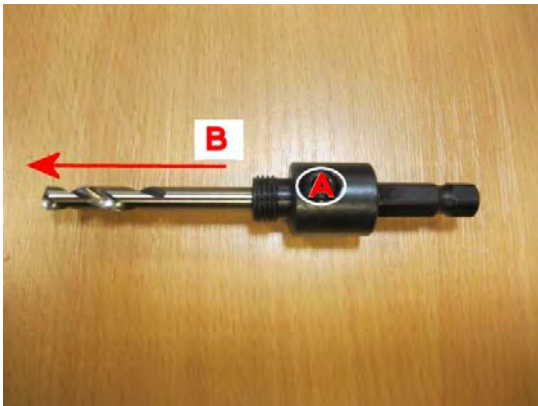

Figure 5

Screw on/secure the 16mm hole saw to the Arbor (Figure 6)



Figure 6

The use of suitable gloves is recommended when applying the adhesive and underseal



Eye protection should be used for the duration of this procedure

.



Ear protection should be used during this procedure when using the hand drill/hole cutting tool

Left and Right hand side orientation is referred to within this document, the left and right hand should be determined as viewed by the operative when standing from the underside of the vehicle looking towards the front (Figure 7)

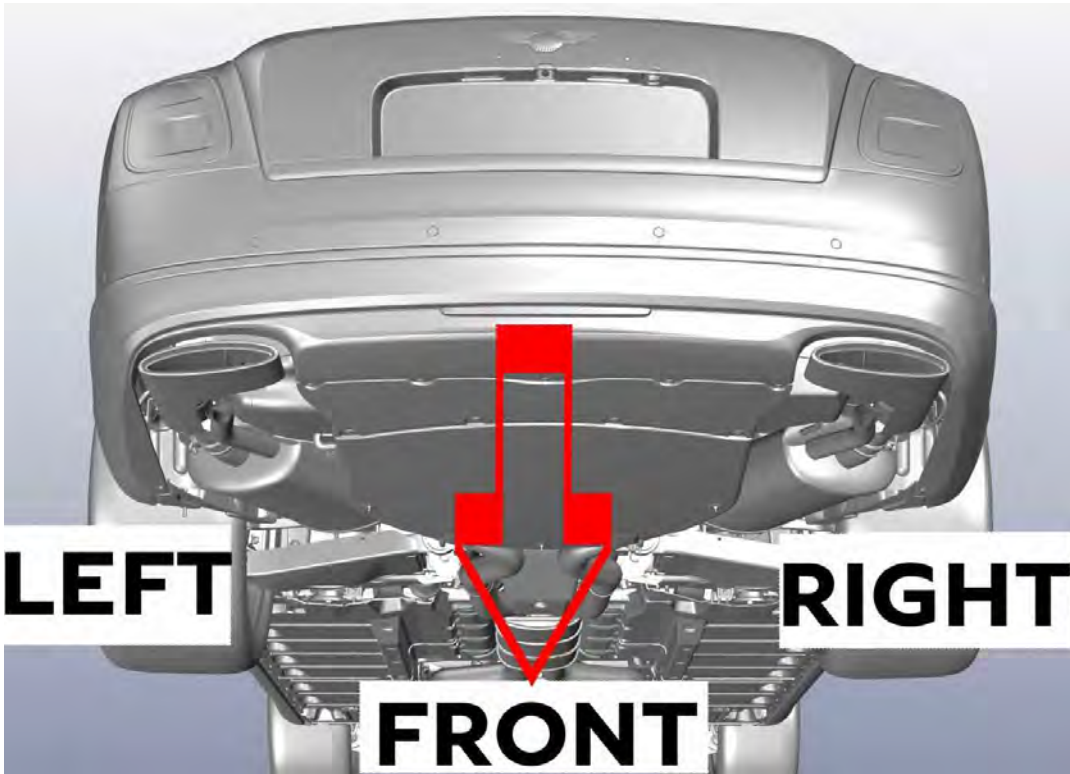

Figure 7

Work

.

Prior to starting the rework procedure ensure all paint and trim components are suitably protected to prevent any damage

1) Remove the left and right hand outer rear seat squabs – Refer to Repair manual Rep.Gr 72



- Use an assistant when removing and refitting the rear seats from the vehicle to eliminate damage to paint and trim components *NOTE: Warranty payments will not be considered for any trim or paint damage to the rear doors (interior/exterior) or the rear cabin trim (wood/leather)*
- Ensure all procedures are followed within the Repair manual when removing the rear seats including the removal of the air bag fuse
- Ensure the remaining central seat is suitably protected for the duration of the procedure
- Ensure the exhaust system has cooled off completely prior to starting any rectification work

Right hand side (As viewed from underside of vehicle looking towards the front)

2) Position the vehicle on a ramp, set the vehicle into "JACK" mode and carry out the usual workshop safety precautions. Refer to Elsa Pro Maintenance section - Raising the vehicle

- Disconnect the right hand rear electrical plugs x2 (Figure 8) *NOTE: Ensure the grommet is not removed from the floor pan during plug disconnection*



Figure 8

- Referring to Figure 9 - Taking care not to damage the pipe and clip, remove the air suspension pipe from the clips x2
- Once the pipe is disconnected from the clips - unscrew the clip x1 shown at (point A) from the stud



Figure 9

- Referring to Figure 10 - With care remove the battery cable clips from the applicable floor studs after removal secure as shown at Point A (for example) - Access to the location shown at Point B is required for underseal removal (*when instructed*)
- Ensure all disconnected components are suitably moved, secured and protected to eliminate the risk of damage during the underseal removal process

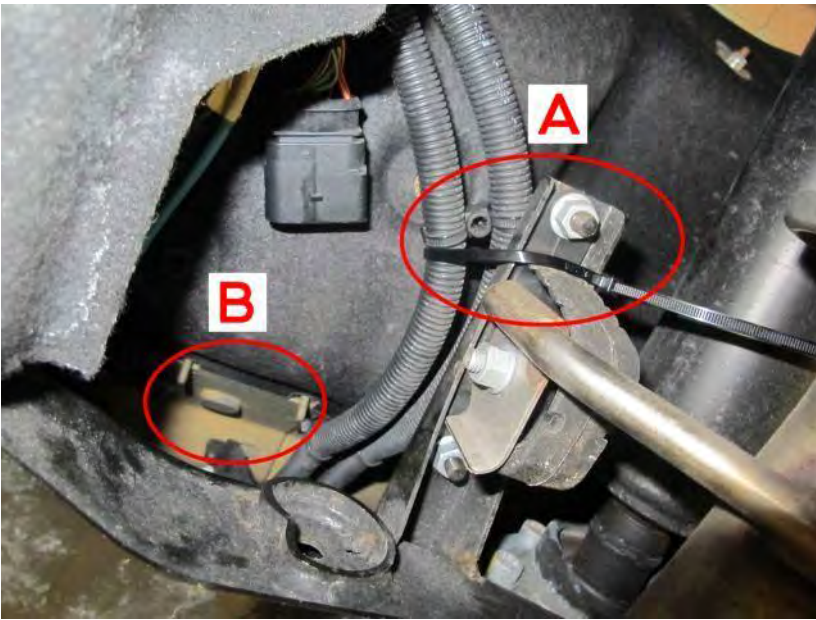

Figure 10

Left hand side (As viewed from underside of vehicle looking towards the front)

3) Referring to Figure 11 - Disconnect the two electrical connections NOTE: Ensure the grommet (Fitted directly above the fuel filter) is not removed from the floor pan during plug disconnection



Figure 11

- Referring to Figure 12 - Taking care not to damage the pipe and clip, remove the air suspension pipe from the clips x2
- Once the pipe is disconnected from the clips - unscrew the clip x1 shown at (point A) from the stud

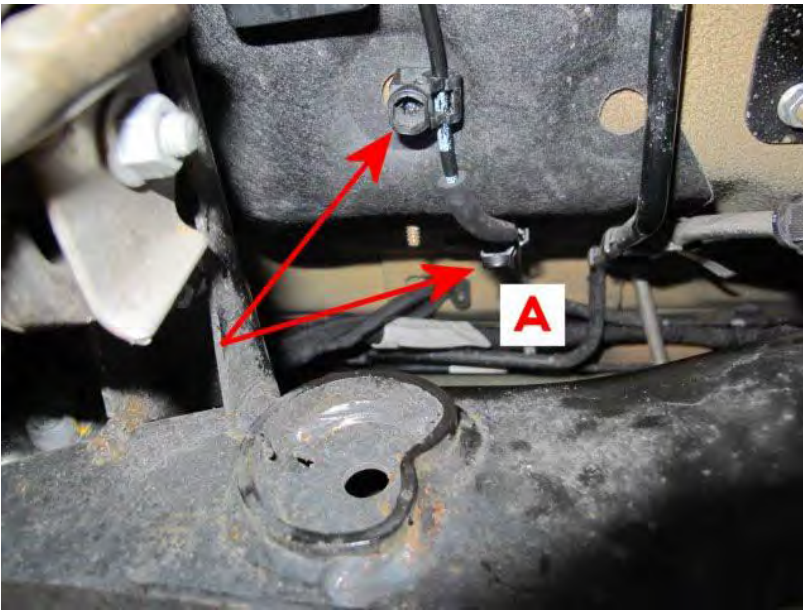

Figure 12

- Referring to Figure 13 (circled) - Ensure all previously disconnected components are suitably moved, secured and protected to eliminate the risk of damage during the underseal removal process (*when instructed*)



Figure 13

4) Referring to Figure 14 – Use a suitable hand drill in conjunction with the Starrett cutting tool assembly - Carefully drill out the left and right hand innermost seat frame fixings to the condition shown in Figure 15

TIP: Carry out a visual inspection of the holes (from the inside and underside of the vehicle) where applicable carefully remove any burrs which may be evident

— Ensure all metal debris as a result of the stud removal is removed from the cabin



Figure 14

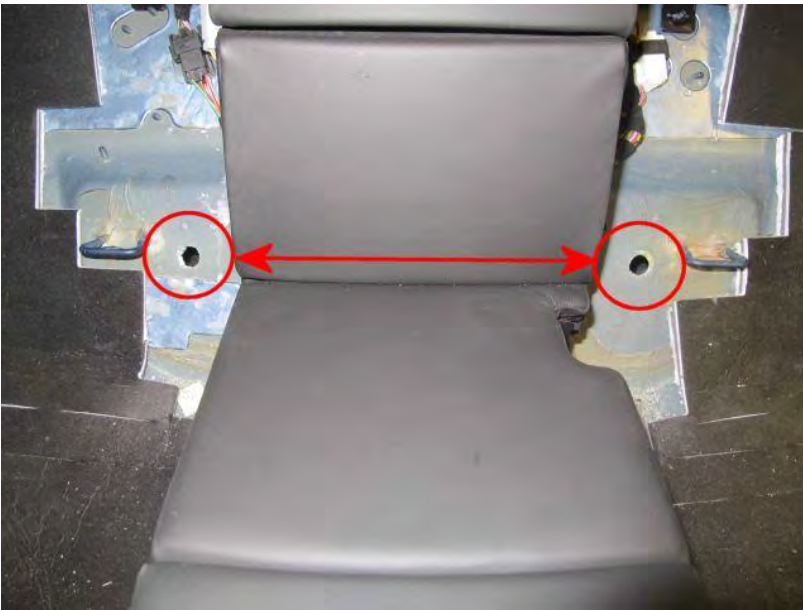

Figure 15

▪
Retrieve the two studs from the underside of the vehicle (top of sub frame/ differential vicinity) once retrieved discard as per local environmental guidelines

5) The next part of the procedure details how to remove specific amounts of underseal from the locations shown in Figure 16

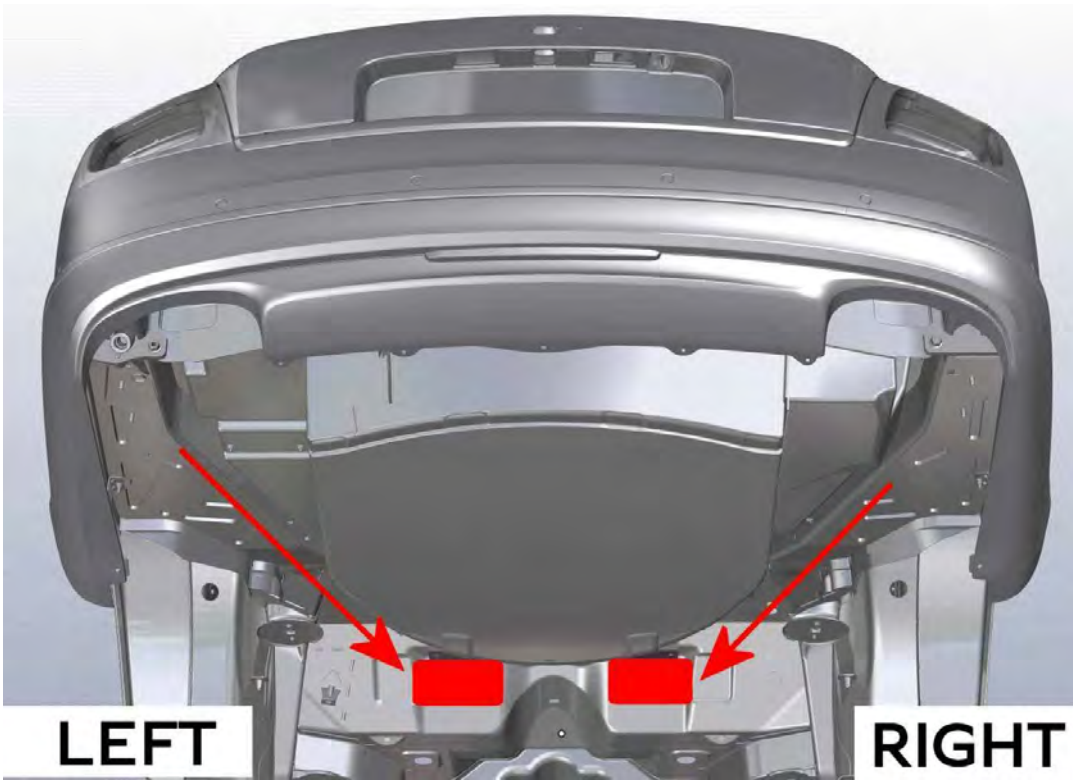

Figure 16

TIP: Although access is tight the required amount of underseal can be removed using the access points shown in Figure 17 without the need to remove any further components

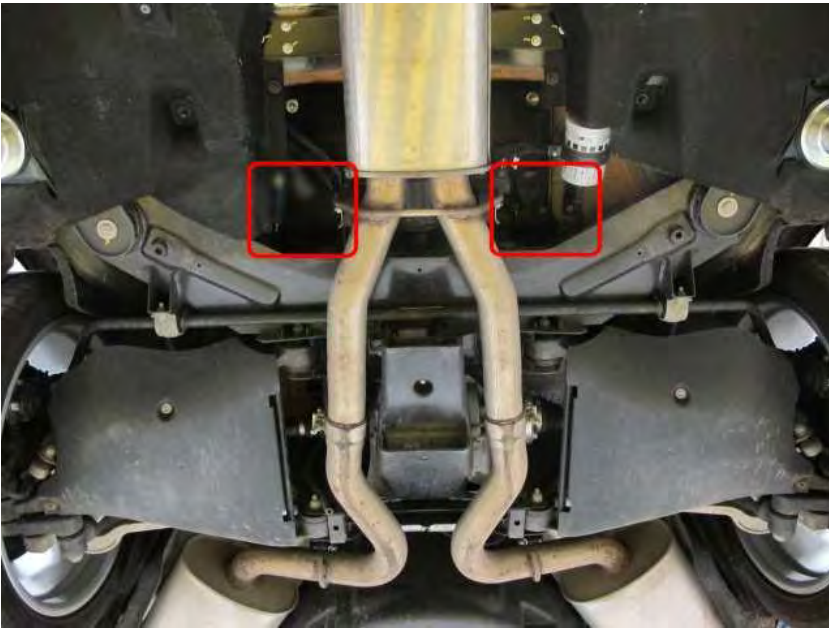

Figure 17

When removing the underseal take extra care not to damage any surrounding components

TIP: The recommended tools for this task are a 600 mm pry bar (Figure 18) with a curved and sharpened end (Figure 19) a small craft knife or scraper may also be used to assist in underseal removal

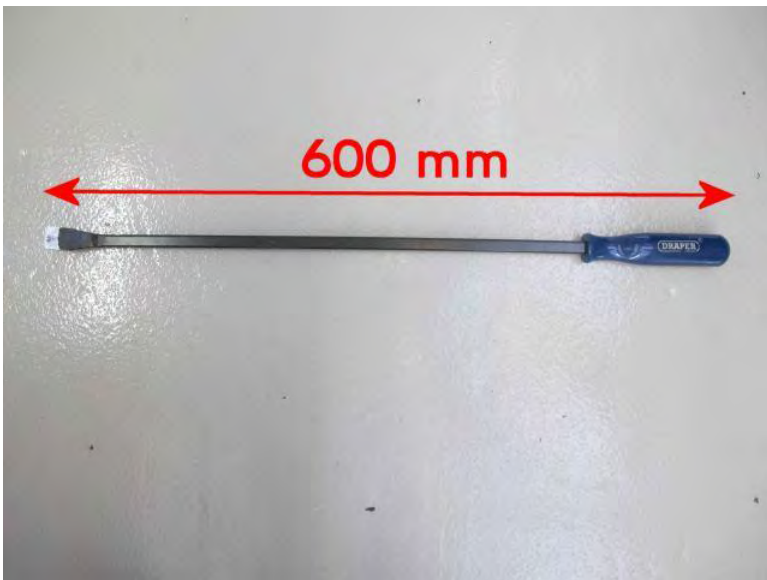

Figure 18



Figure 19

6) Referring to Figure 20 - Scrape/remove the underseal from the areas shown on the right and left hand side, once removed use fine grade sandpaper to remove any remaining underseal

It is imperative that the areas shown in Figure 20 are completely free of underseal as per the dimensions provided, should the operative **NOT** remove **ALL** underseal the fitting location of the plates in relation to the floor panel may be compromised

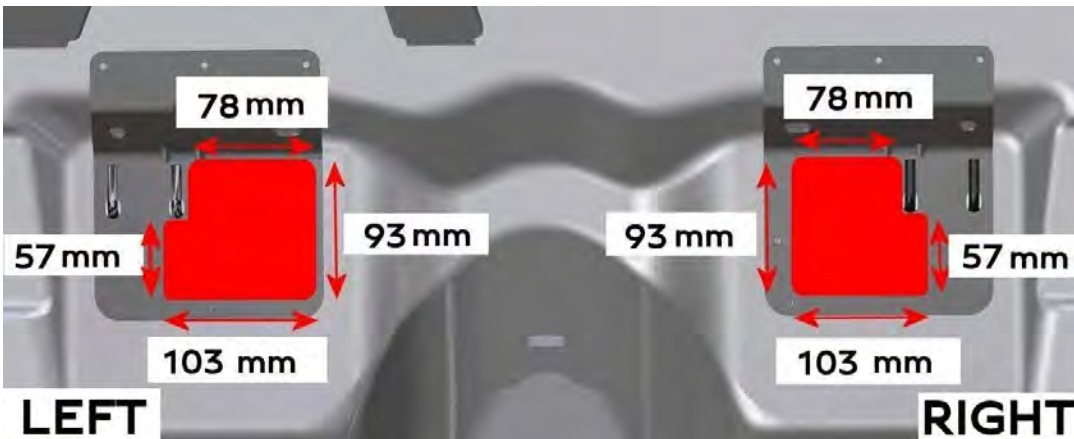

Figure 20

Access the underseal removal points using the recommended scraping tool as per Figure 21 (access points are the same on both the left and right hand sides)

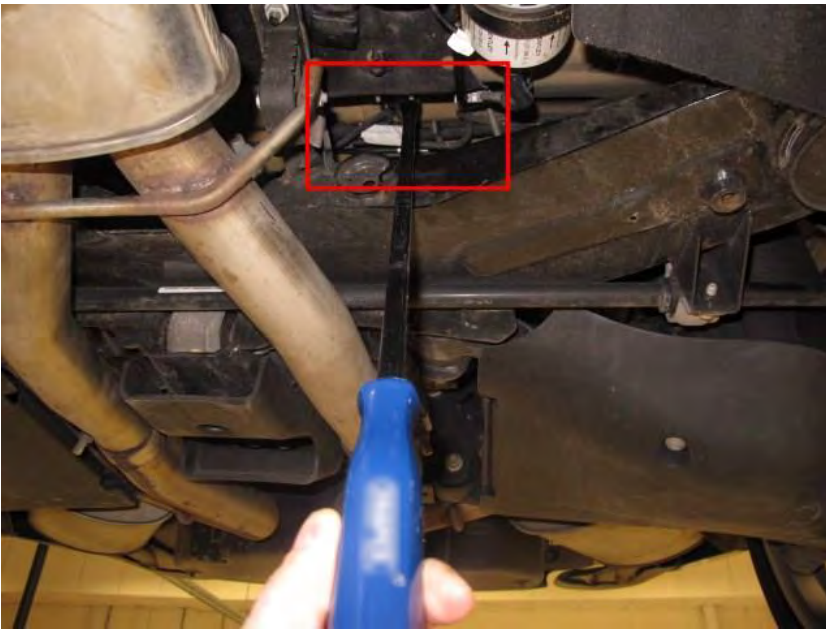

Figure 21

CAUTION: The use of power tools to remove underseal is not recommended due to the risk of damage to nearby components
IMPORTANT: Warranty payments will not be considered for any damage to components in the immediate vicinities in which the underseal is required to be removed from

Use an airline to remove all loose underseal debris from the surrounding area **IMPORTANT:** Ensure no underseal is left on or nearby the exhaust system/differential area

7) **VERY IMPORTANT:** Confirm the underseal is **COMPLETELY** removed from the left and right hand sides Figure 22 shows the left hand side, Figure 23 shows the right hand side



Figure 22



Figure 23

8) Referring to Figure 24 apply DP 490 or equivalent to the **Inner** mating face of left hand plate part number 3Y5 803 621

- Referring to Figure 25 apply in the pattern shown onto the inner mating face, ensure a ring of adhesive with a 23mm diameter is applied around the plate stud shown at Point A



Figure 24

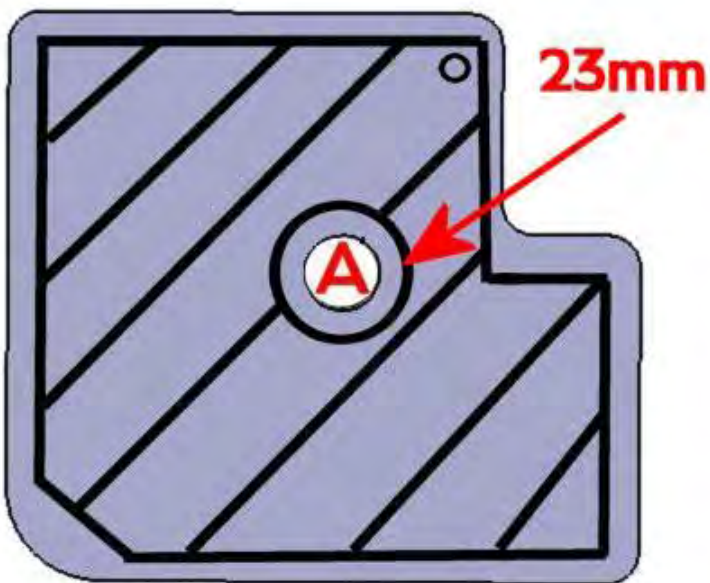

Figure 25

9) Repeat Step 8 on the **Inner** mating face of the right hand plate with the part number of 3Y5 803 622

For procedures 10 through to 11 two operatives are required, the first is required for fitting and locating the plates in the correct orientation/position, whilst the second should be inside the vehicle to locate and fit the rear seat belts and seats

10) Referring to Figure 26 - Fit and locate the left hand plate **3Y5803621**



Figure 26

- Repeat the fit and locate process on the right hand plate **3Y5803622**

- Referring to Figure 27 - Ensure the plates are positioned exactly as shown, the isofix welds (Circled) should be used to locate and position the plates
The holes which are drilled through each plate (Point A) can also be used for confirmation regarding correct fitting location

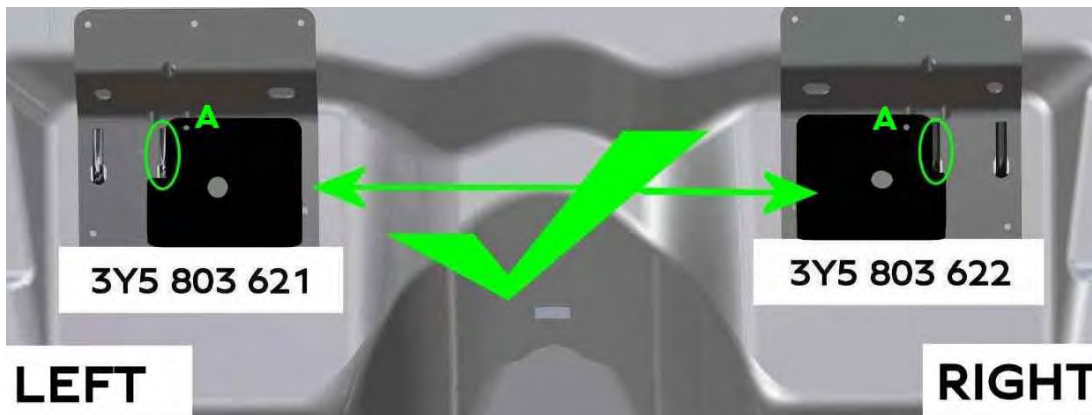

Figure 27

NOTE: The next part of the process requires the rear seats refitting - Use an assistant when refitting the rear seats from the vehicle to eliminate damage to paint and trim components **NOTE: Warranty payments will not be considered for any trim or paint damage to the rear doors (interior/exterior) or the rear cabin trim (wood/leather)**

- Referring to Figure 28 - Clean any excess adhesive which may have transferred onto the left hand thread

- Before locating the left hand seat - Ensure the seat belt buckle -1- is in position on the inboard stud, the antirotation tab (Arrow) - on the buckle bracket must be located against the bottom side of the isofix loop -2-

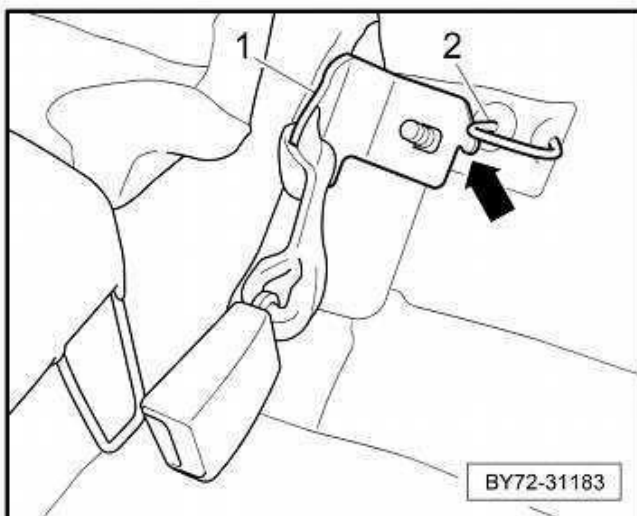

Figure 28

- Referring to Figure 29 - Before installing the right hand squab - Clean any excess adhesive which may have transferred onto right hand thread

- When installing the right hand squab, ensure the webbing plate -2- is positioned on the inboard mounting stud -3- BEFORE locating the base of the seat frame -4- over the top of the webbing plate -2-

The seat belt webbing -1- will be routed through a guide clip when refitting the seat cushion. Refer to "Rear seat cushion — To remove and fit". → Rep.-Gr.72

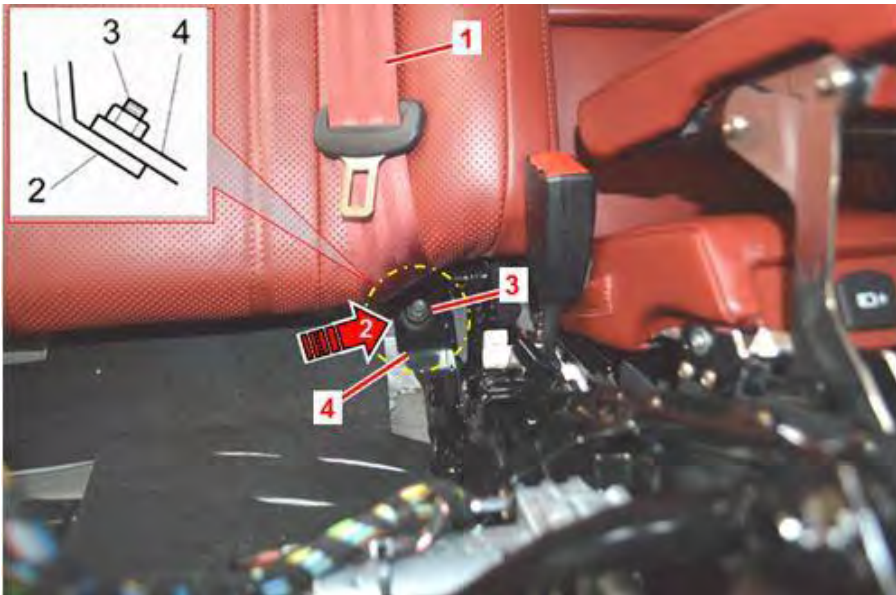

Figure 29

11) With the rear seat squabs in position ensure the second operative is holding the plates in the required location from the underside **CAUTION: The next part of the process involves securing the plate fixings from inside the vehicle, care should be taken that the person holding the plates does not allow their fingers to be trapped between the plates and floor pan during this operation**

- Referring to Figure 30, Carry out a visual check to confirm the plates are fitted/located correctly before securing the seat frame fixings



Figure 30

- Referring to Figure 31 - Confirm the **left and right hand** plates are not overlapping the underbody protection

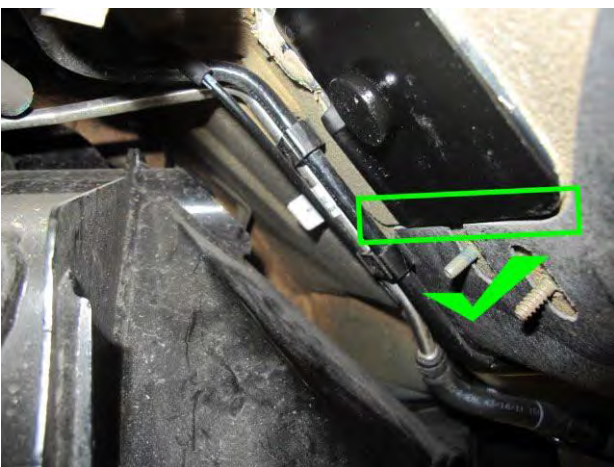

Figure 31

- Secure the rear seat fixings to the specified torque as per Repair manual Rep.Gr 72
- Carry out a pull test to confirm the centre seat belt buckle and anchor are located and secured to specification as per Repair manual Rep.Gr 72
- Complete the fitting of the rear seats as per the Repair manual Rep.Gr 72
- From the underside, clean any excess adhesive from the sides of the plates which may have squeezed out from the plates during the securing process

12) Apply Underseal to the right and left hand plates - Due to the tight location the recommendation for underseal application is to wear gloves and apply the underseal by hand

- Referring to Figure 32 - Manually apply the underseal to all four edges of the left hand plate (Point A) ensure the outer face of the plate is covered (Point B)
- Ensure all outer edges are backfilled from the plate onto the floor panel to create a watertight seal

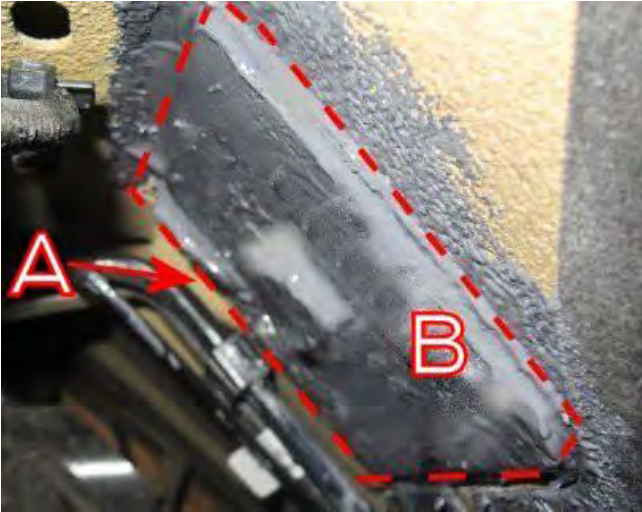

Figure 32

- Repeat step 12 on the right hand plate
- Clean any excess underseal from any surrounding components

13) Referring to Figure 33 - Use a suitable inspection mirror to check underseal is correctly applied to the left and right hand plates **including** the outer edges to the rear floor panel NOTE: Should any points be found with no underseal the operative must apply further underseal to the required locations



Figure 33

14) **Right hand side**

- Reconnect and secure the electrical plugs x2
- Refit the previously removed air suspension pipe clip, then refit the air suspension pipe into the clips x2
- Secure the battery cables to the floor studs
- Confirm the harness floor grommet is fitted correctly within the floor pan (Figure 34)



Figure 34

15) **Left hand side**

- Reconnect and secure the electrical plugs x2

- Refit the previously removed air suspension pipe clip, then refit the air suspension pipe into the clips x2
- Confirm the harness floor grommet is fitted correctly within the floor pan (Directly above fuel filter Figure 35)

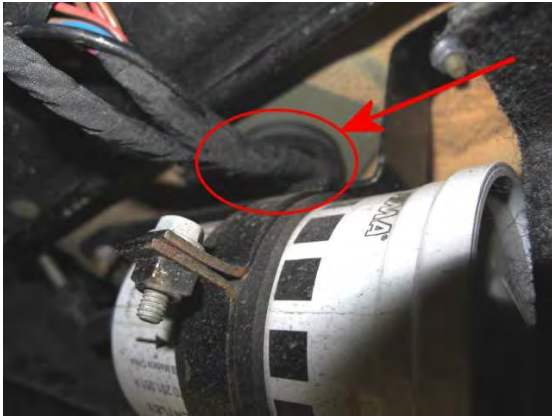

Figure 35

IMPORTANT: Ensure the air bag fuse is refitted

- Clear any **DTC's** which may be evident as a result of conducting this procedure

16) Apply a Yellow paint mark on the underside of the left hand rear door harness connector (Figure 36)



Figure 36

Identification

Yellow paint mark on the underside of the left hand rear door harness connector (Figure 36)

• **Repair instructions** • **Notes**