

IMPORTANT UPDATE
TECHNICAL INSTRUCTIONS

FOR

SAFETY RECALL GLG/GLH/HLA

FRONT PASSENGER AIRBAG INFLATOR REPLACEMENT

CERTAIN 2010-2015 MY IS 250/350 CONVERTIBLE

UPDATED 1-14-2021

1-14-21

- The scanning process has been updated

1-9-19

- Added up to 2015 MY
- Updated title to include GLH and HLA

4-18-2018

- The parts section has been updated

1-9-2018

- Added 2013 model year

9-21-2017

- Added 2011 and 2012 model year

7-19-2017

- Correction to Flowchart on page 2
- Notation added on page 28

6-30-2017

- Correction to the picture on page 9.

The repair quality of covered vehicles is extremely important to Lexus. All dealership technicians performing this recall are required to successfully complete the most current version of the E-Learning course "Safety Recall and Service Campaign Essentials". To ensure that all vehicles have the repair performed correctly:

- **MASTER SERVICE TECHNICIANS**
- **MASTER DIAGNOSTIC SPECIALISTS**

It is the dealership's responsibility to select technicians with the above certification level or greater to perform this recall repair. Carefully review your resources, the technician skill level, and ability before assigning technicians to this repair. It is important to consider technician days off and vacation schedules to ensure there are properly trained technicians available to perform this repair at all times.

NOTE: To support additional service capacity, Lexus Certified and Senior Service Technicians, with at least 36 months Lexus experience AND L652 course credit, may also perform this repair following successful completion of course LSC13B.

I. OPERATION FLOW CHART

The flow chart is for reference only. **DO NOT** use it in place of the full technical instructions. Follow **ALL** steps as outlined in the full technical instructions to confirm the campaign is completed correctly.

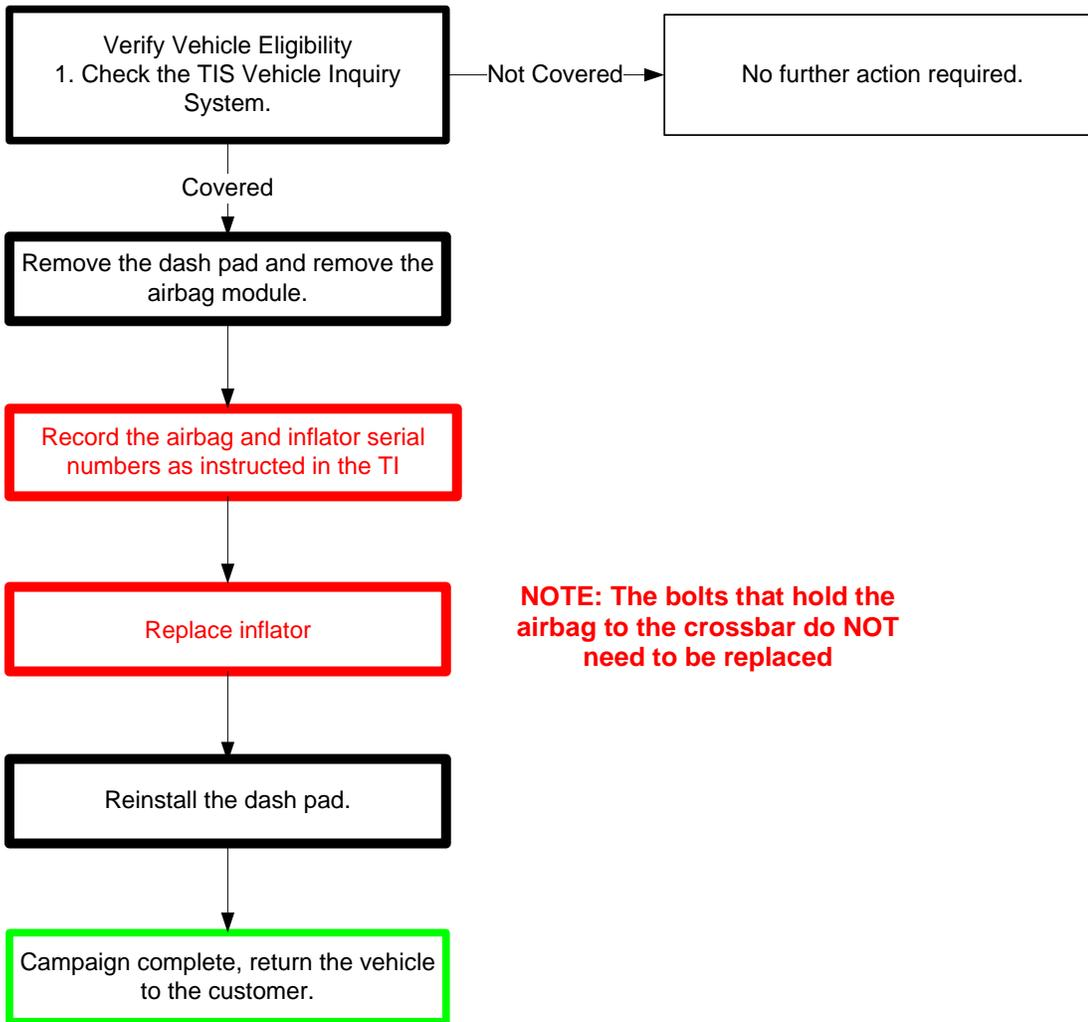

II. BACKGROUND

The subject vehicles are equipped with front passenger airbag inflators produced by Takata. The propellant in these inflators may degrade after prolonged exposure to high absolute humidity and fluctuating high temperatures. Degraded propellant can cause inflator rupture during airbag deployment. In the event of an inflator rupture, metal fragments could pass through the airbag cushion material, striking the vehicle occupants, and result in serious injury or death.

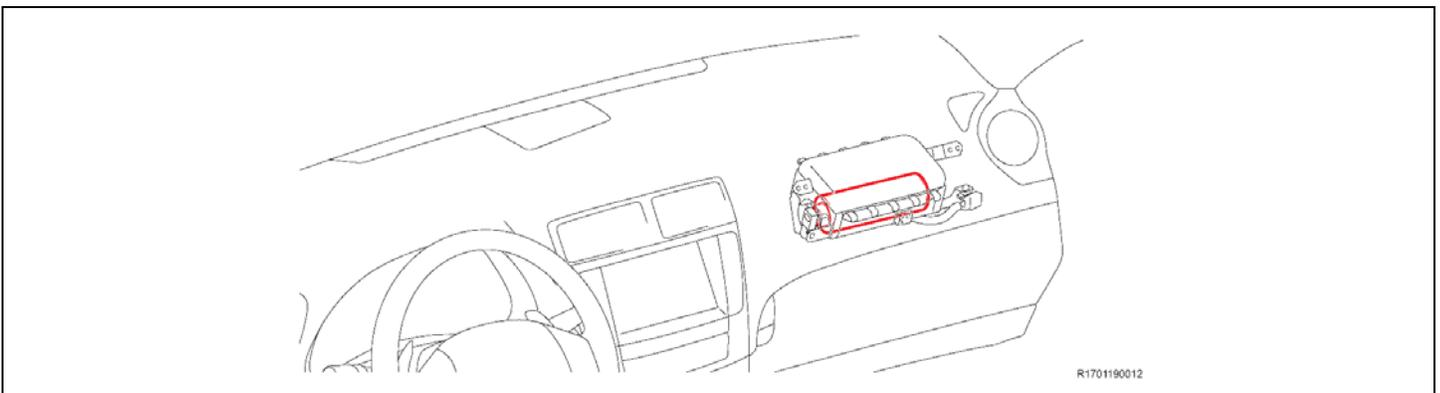

III. IDENTIFICATION OF AFFECTED VEHICLES

A. COVERED VIN RANGE

- Check the TIS Vehicle Inquiry System to confirm the VIN is involved in this Safety Recall, and that the campaign has not already been completed prior to dealer shipment or by another dealer.
- **TMS warranty will not reimburse dealers for repairs conducted on vehicles that are not affected or were completed by another dealer.**

IV. PREPARATION

A. PARTS

Part Number	Part Description	Quantity
04007-06353	Instrument Panel Passenger Airbag Inflator Kit*	1
*The kit above includes the following parts.		
Part Number	Part Description	Quantity
-	Inflator	1
-	Self-locking Nut	5
-	Position Determining Plate	1

Non-Desiccated Part Recovery

Dealers should discontinue the installation of the non-desiccated parts listed below for recall, customer pay repairs AND over-the-counter sales (if applicable).

Model	Model Year	Part Number	Part Description
IS 250 – IS 350, IS-F and IS 250C – IS350C	2006-2015	73960-53020 73960-53060	AIR BAG ASSY, INSTR PNL PASS L/DOOR

Lexus requires all dealers to return any parts listed above that still remain in dealer inventory by utilizing the Hazmat Part Return Program available. Dealers will be issued a refund for all part returns. This part return program is outlined in *PANT Bulletin 2014-042*.

Important Note:

In order to return the inflator, packages must **NOT** be opened/tampered with.

B. TOOLS & EQUIPMENT

- Standard hand tools
- Torque wrench
- Techstream
- Molding remover set

GLG/GLH/HLA CAMPAIGN TOOLS – These tools are required when performing this repair.

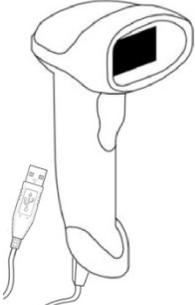
Image	Name	Quantity
	Barcode Scanner (The scanner was previously proved for SSC GLC)	1

NOTE: This scanner CANNOT be ordered through the parts or tools system. There is a very limited supply of tools, but if additional tools are needed, contact your area representative.

DLC CAMPAIGN TOOLS – These tools are required when performing this repair.

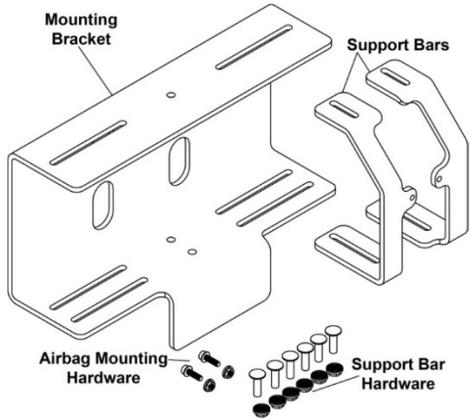
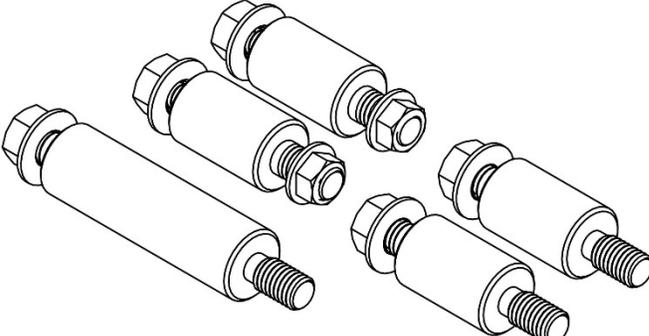
Image	Name	Quantity
	<p>Airbag Mounting Bracket & hardware (Provided to the dealership at the launch of SSC DLC)</p>	<p>1</p>
	<p>579943 Adaptor set*</p>	<p>1</p>

*The adapter set was sent to dealers prior to the start of this campaign.

SST –These are essential service tools that the dealership should have.

Part Number	Part Name	Quantity
09950-50013	Puller C Set *	1
* The set above includes the following tools.		
Part Number	Part Name	Quantity
09951-05010	Hanger 150	1
09952-05010	Slide Arm	2
09953-05020	Center Bolt 150	1
09954-05021	Claw No. 2	2

V. SAFETY PRECAUTIONS



CRITICAL INFORMATION – READ THOROUGHLY



Failure to follow these procedures correctly could cause the SRS to unexpectedly deploy during servicing or the SRS may fail to operate correctly when required after reassembly. Confirm all work is performed as described in these instructions.

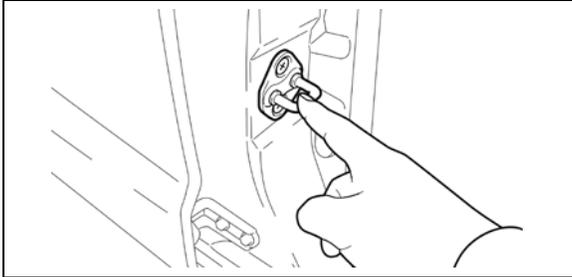

1. ELIMINATE STATIC ELECTRICITY

- a) Before starting work and periodically while working on the vehicle, touch a metallic part of the vehicle to discharge static electricity in the body.

NG DO NOT measure resistance.

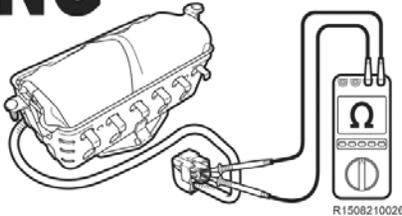

2. DO NOT MEASURE RESISTANCE

- a) **DO NOT** measure resistance of airbag components, this may cause accidental activation.

NG Replace with new one.

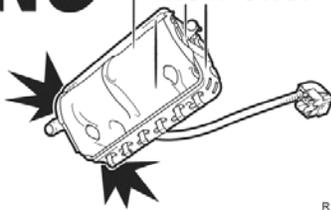

3. HANDLE THE AIRBAG CAREFULLY

- a) If an inflator is dropped, replace it with a **NEW** inflator.

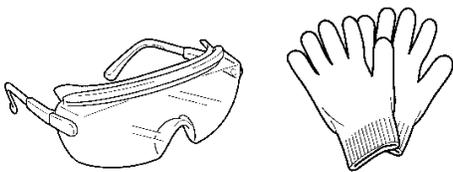

Wear protective eye wear and work gloves.

4. WEAR PROTECTIVE EQUIPMENT

- a) Always wear appropriate protective equipment when working on the SRS.

VII. FRONT PASSENGER AIRBAG REMOVAL COMPONENTS

for Automatic Transmission:

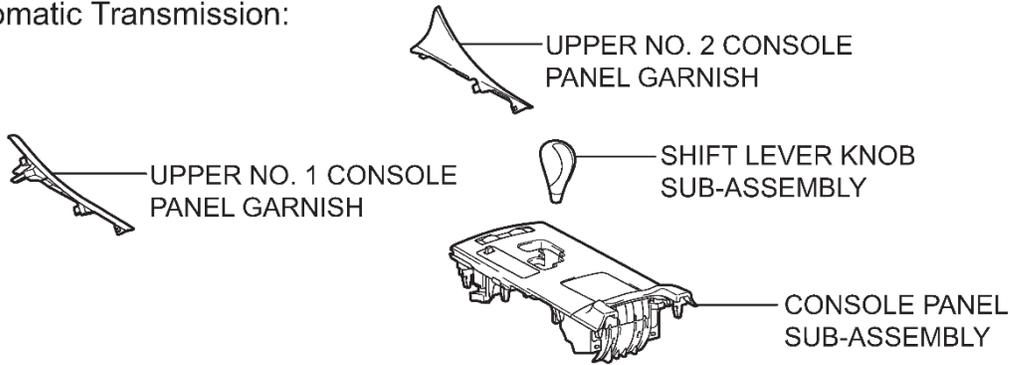

for Manual Transmission:

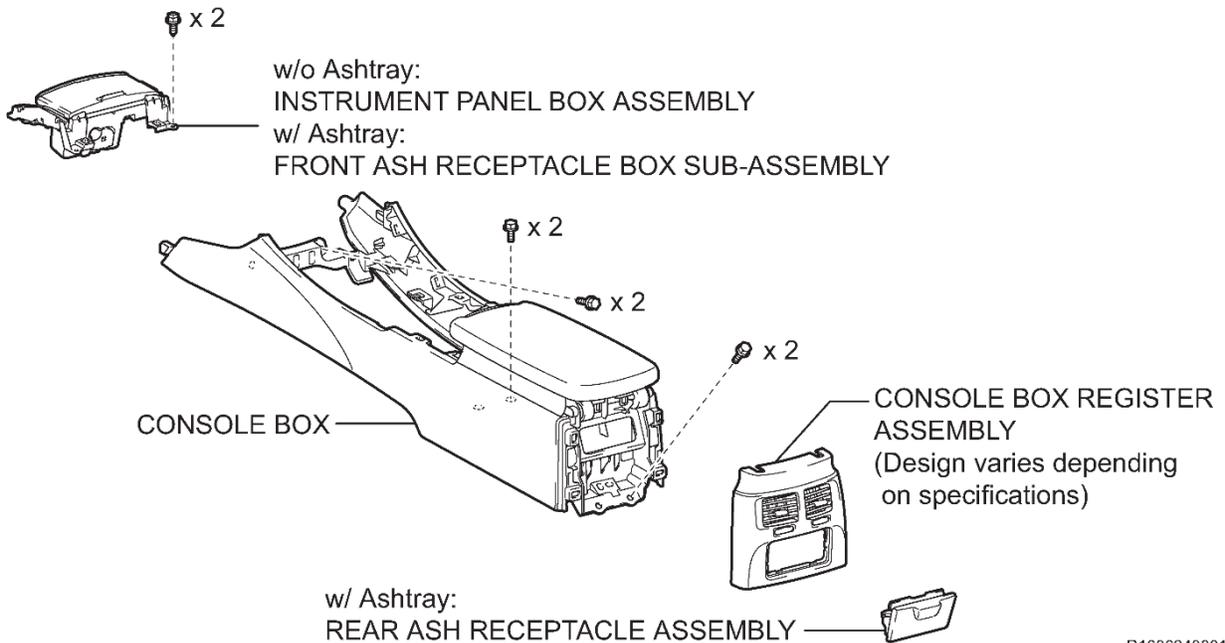
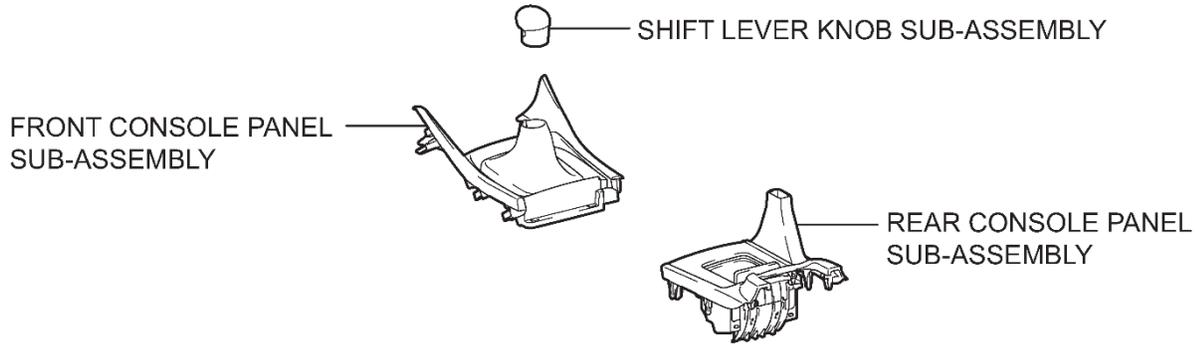

R1606240001

TURN SIGNAL SWITCH ASSEMBLY WITH SPIRAL CABLE SUB-ASSEMBLY

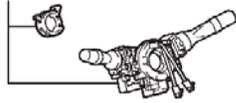

STEERING COLUMN COVER



(for Power Tilt and Power Telescopic Steering Column)

COMBINATION METER ASSEMBLY

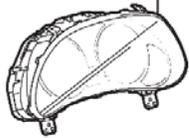

STEERING WHEEL ASSEMBLY



50 (510, 37)

LOWER NO. 3 STEERING WHEEL COVER

LOWER NO. 2 STEERING WHEEL COVER

INSTRUMENT CLUSTER FINISH PANEL SUB-ASSEMBLY

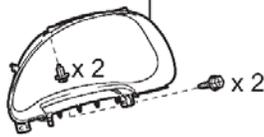

8.8 (90, 78 in.*lbf)

STEERING PAD

POWER SOURCE CONTROL ECU

13 (126, 9)



11 (107, 8)

SIDE INSTRUMENT PANEL LH



LOWER INSTRUMENT PANEL FINISH PANEL SUB-ASSEMBLY

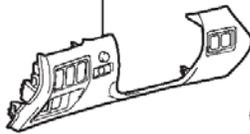

SIDE INSTRUMENT PANEL RH



GLOVE COMPARTMENT DOOR ASSEMBLY

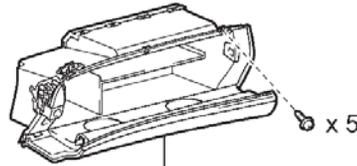

DRIVER SIDE KNEE AIRBAG ASSEMBLY

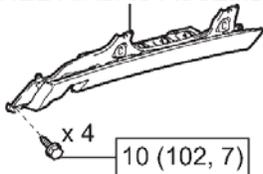

10 (102, 7)

FRONT DOOR OPENING TRIM COVER RH



FRONT PASSENGER SIDE KNEE AIRBAG ASSEMBLY

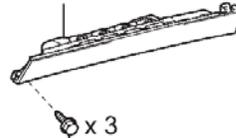

10 (102, 7)

FRONT DOOR OPENING TRIM COVER LH



FRONT DOOR SCUFF PLATE RH



NO. 1 INSTRUMENT PANEL UNDER COVER SUB-ASSEMBLY (Design varies depending on specifications)

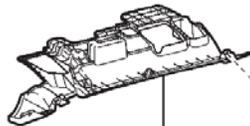

FRONT DOOR SCUFF PLATE LH

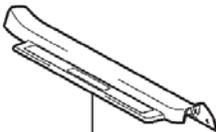

NO. 2 INSTRUMENT PANEL UNDER COVER SUB-ASSEMBLY

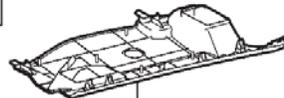

N*m (kgf*cm, ft*lbf) : Specified torque

R1606240002

NO. 3 INSTRUMENT PANEL
SPEAKER PANEL SUB-ASSEMBLY

w/ Front Center Speaker:
FRONT STEREO COMPONENT
SPEAKER ASSEMBLY
or FRONT NO. 4 SPEAKER ASSEMBLY

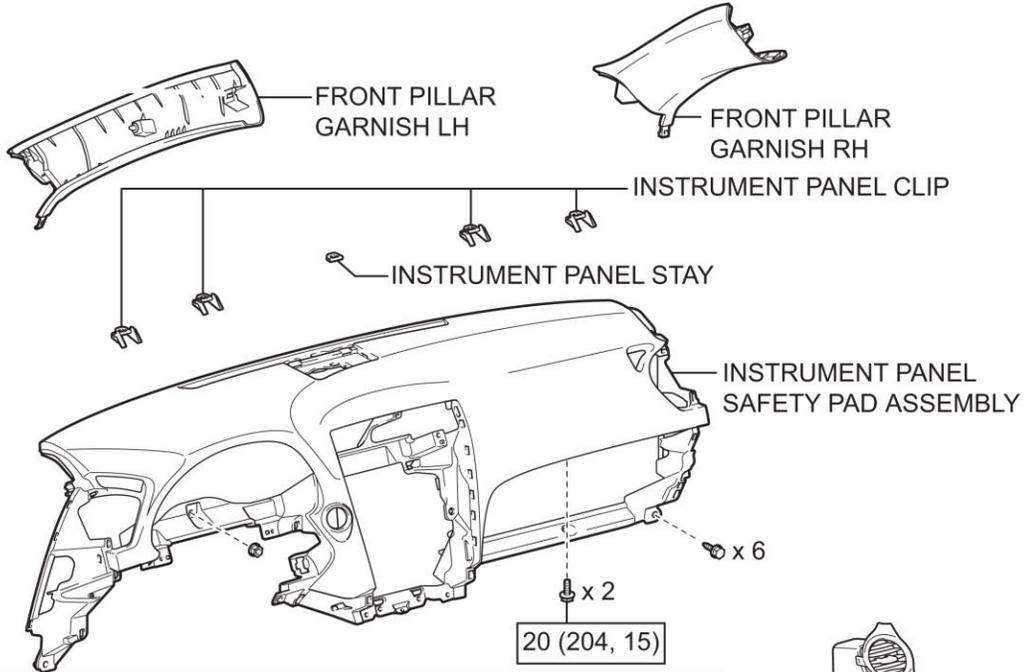
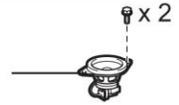

BE CAREFUL!
DO NOT pry from the outside
with a moulding remover or the like.

NO. 3 INSTRUMENT
PANEL REGISTER ASSEMBLY



NO. 2 INSTRUMENT PANEL
REGISTER ASSEMBLY



NO. 1 INSTRUMENT PANEL
REGISTER ASSEMBLY



INTEGRATION CONTROL PANEL or
MULTI-DISPLAY or
DISPLAY AND NAVIGATION MODULE DISPLAY
WITH RADIO RECEIVER ASSEMBLY

CENTER LOWER INSTRUMENT
CLUSTER FINISH PANEL

NO. 1 CONSOLE BOX DUCT

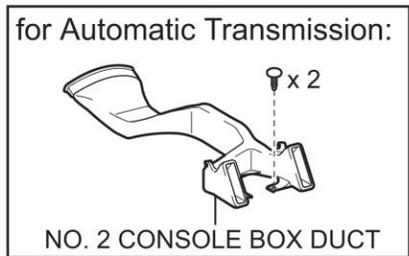
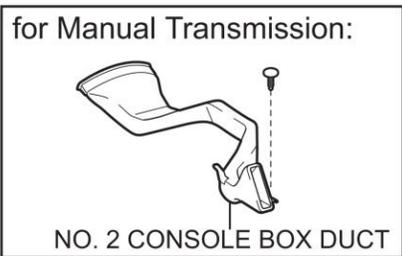

N*m (kgf*cm, ft*lb) : Specified torque

R1606240003

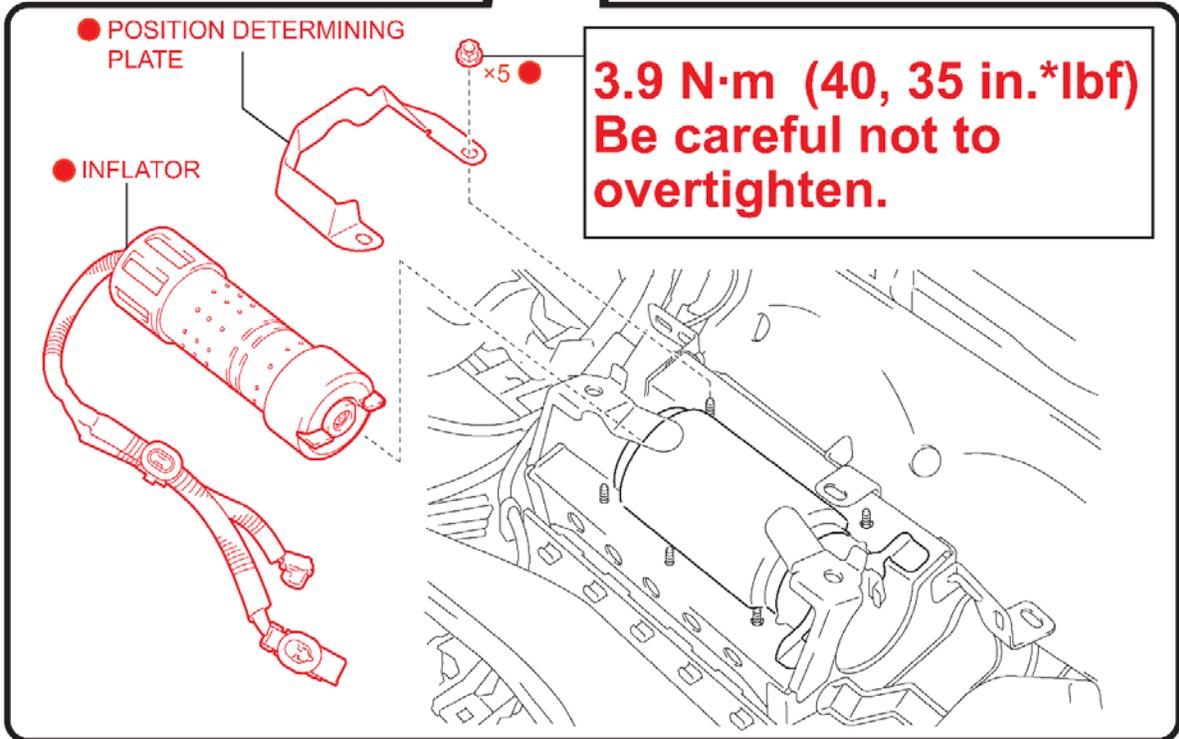
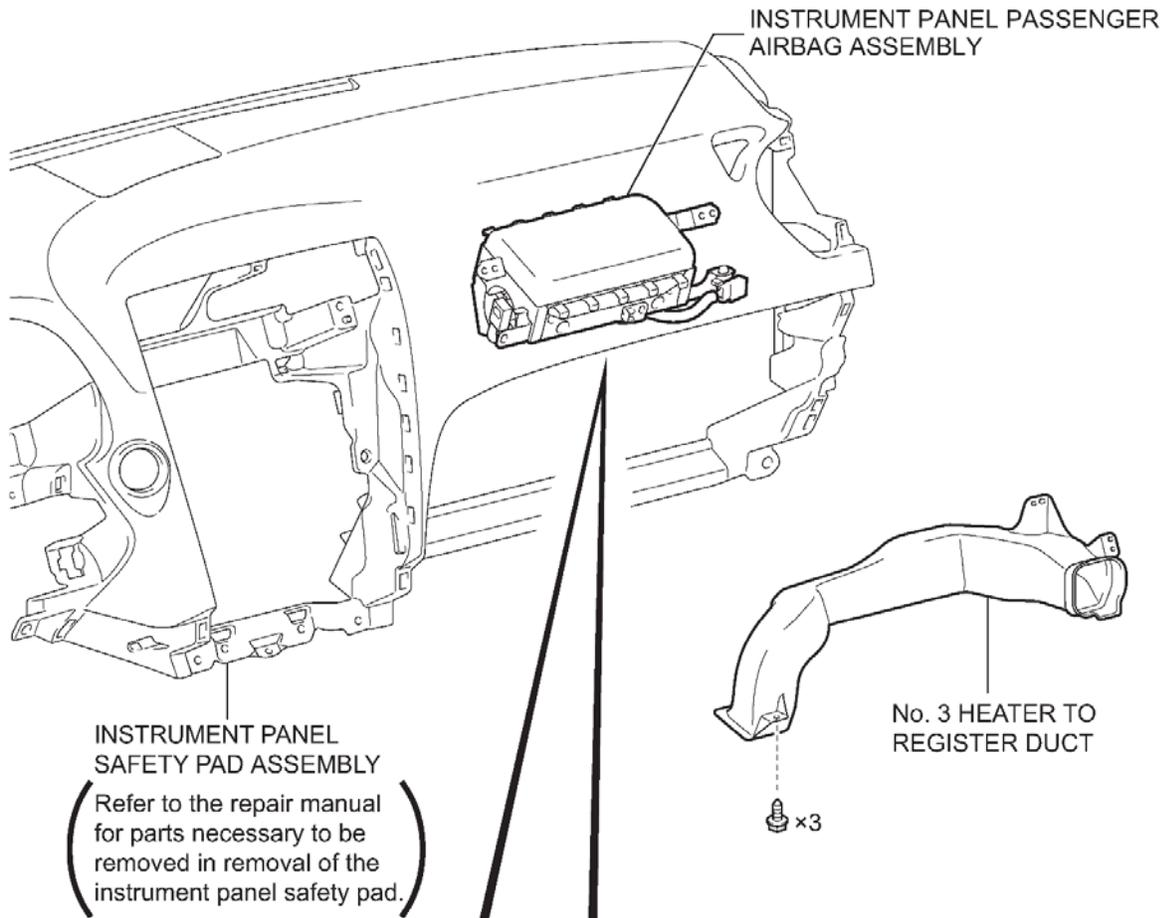

● : Replacement part

R1701280024Z01

1. DISCONNECT THE NEGATIVE BATTERY TERMINAL



- Wait at least 90 seconds after disconnecting the cable from the negative battery terminal to prevent airbag and seat belt pre-tensioner deployment.
- Follow all precautions as outlined on TIS before servicing the SRS system.

2. INSTRUMENT PANEL PRECAUTIONS AND REMOVAL



Prior to dash removal make note of the following precautions. Over time some dash components could be easily damaged if not carefully removed.

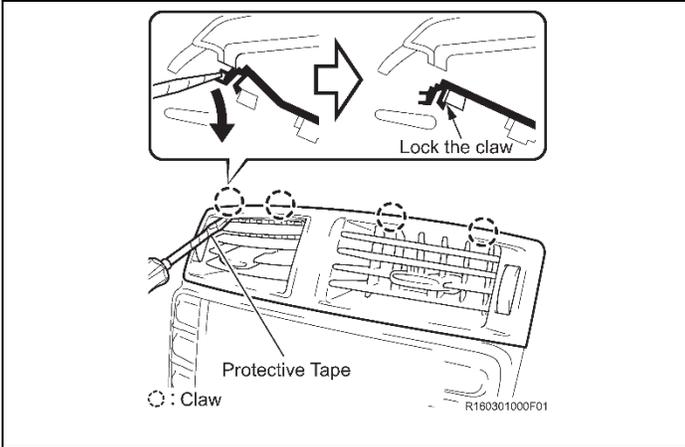

Removing the No. 3 air register

Remove any peripheral parts on left and right side of the register to allow access to the back of the register.

Wrap the tip of a screwdriver with tape.

Lock the 4 claws inside the register as shown.

NOTE: Do not use a molding removal tool to remove the register it could be damaged.

NG Do not use a molding remover

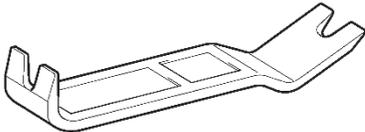

R1606160001F01

NG Do not push connector or wire harness

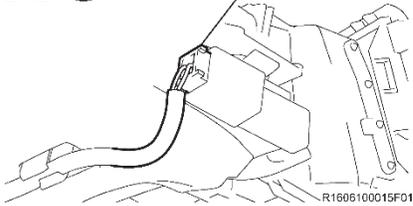

R1606100015F01

NOTE: When removing the register DO NOT push on the connector or wiring as it could be damaged.

You will remove the register by pushing from the back.

【Example for removal of center register】

OK Push from the back side

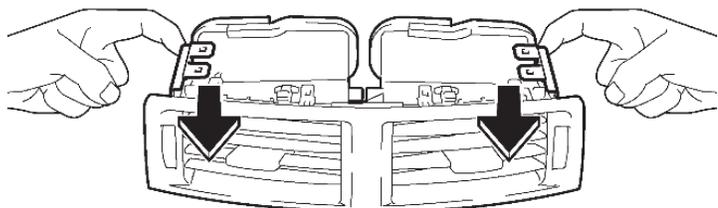

NG Pry from the front side

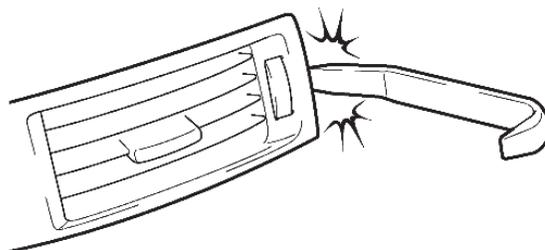

R1606130005F01

Using your finger on the left side push out at the point shown to disengage the 4 claws.

Back side of part manufactured before August 2008:

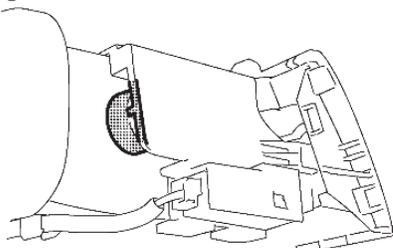

Back side of the part manufactured after August 2008:

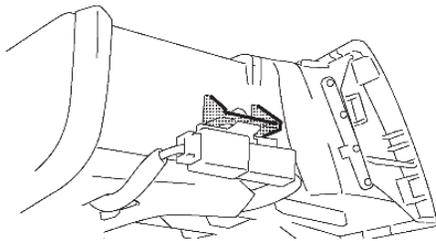

○ : Claw

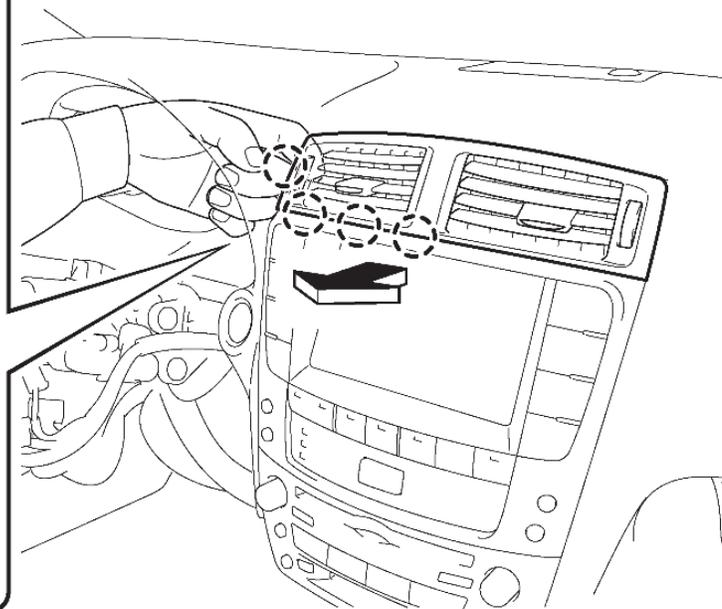

R1606100013F01

Using your finger on the right side push out at the point shown to disengage the 3 claws and remove the register from the instrument panel.

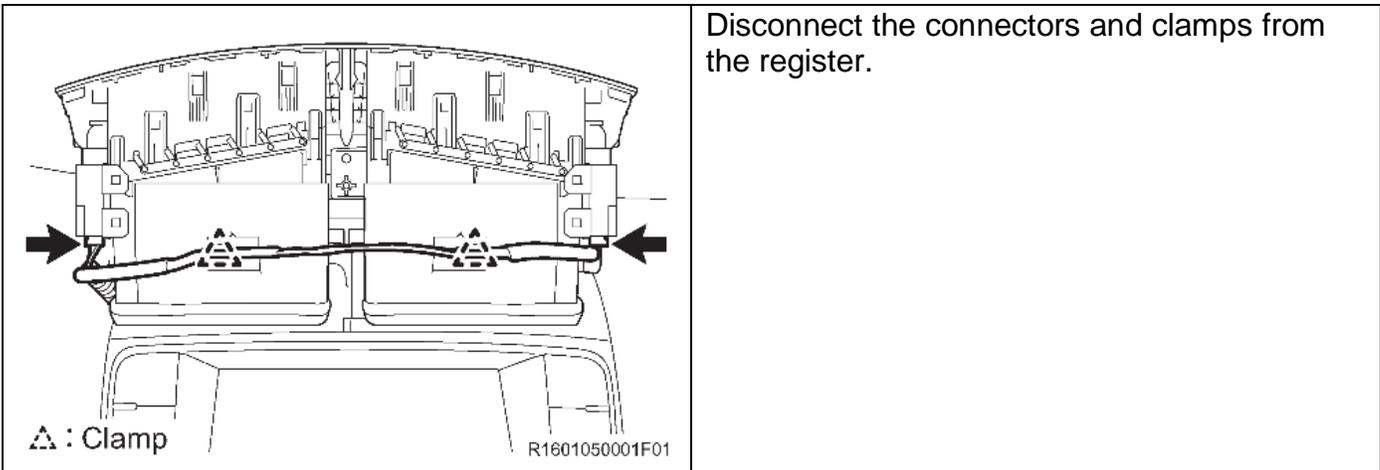
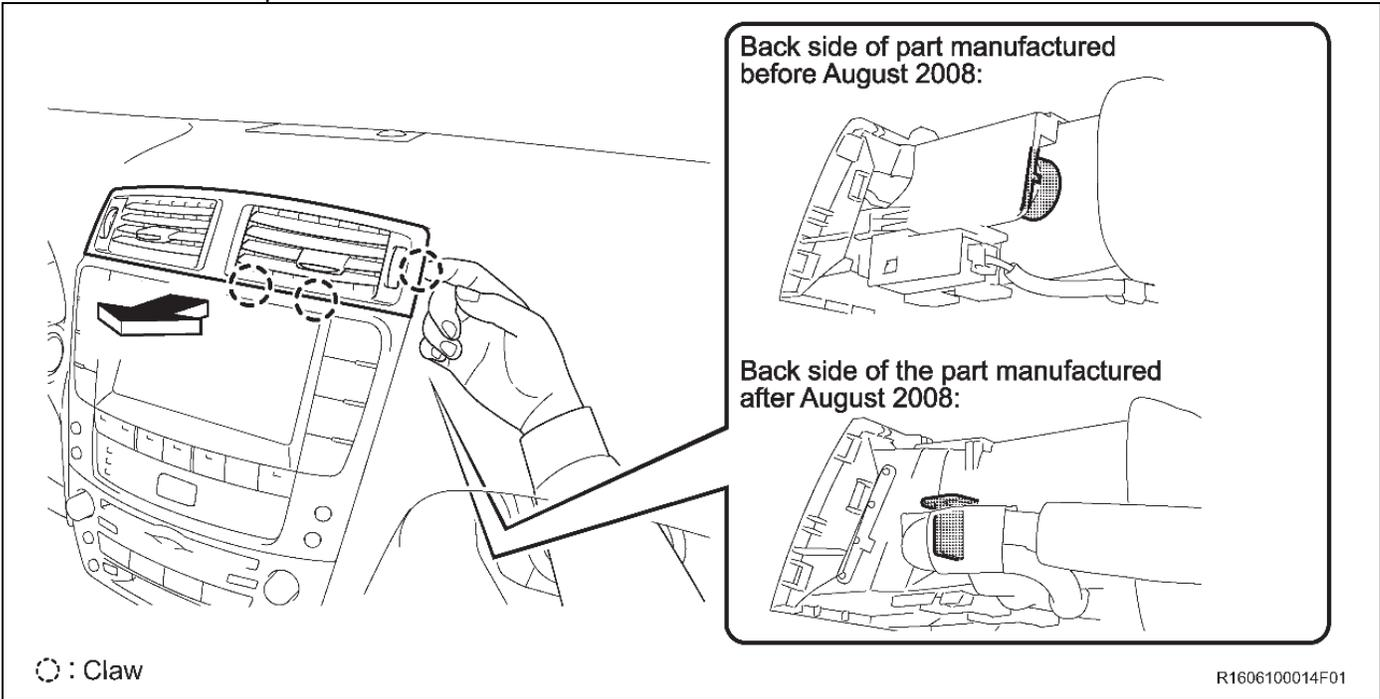

NOTE: DO NOT contact the postioning tabs while removing the instrument panel as the panel could be damaged.

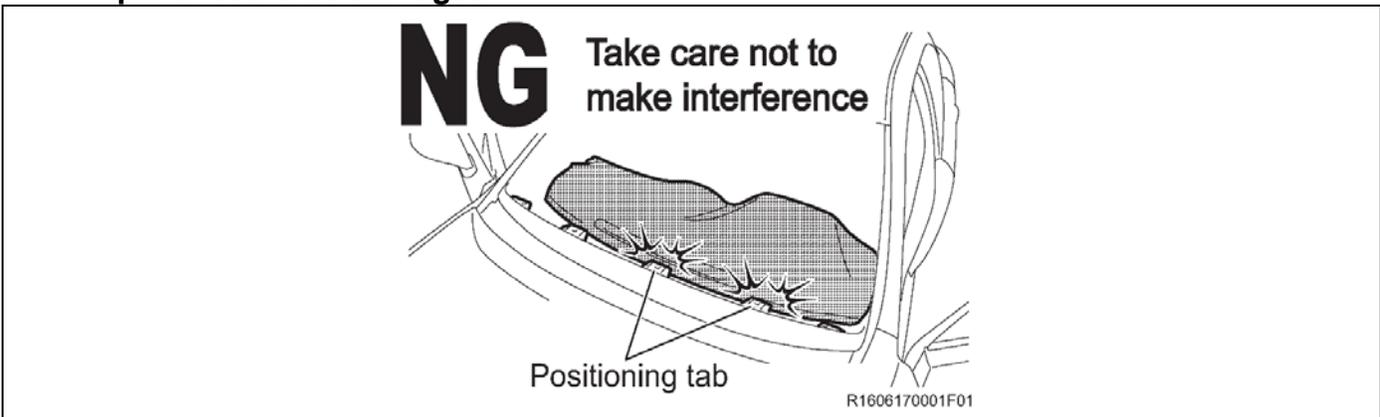

a) Refer to TIS for removal instructions

IS Convertible	2010 MY	2011 MY	2012 MY	2013 MY	2014 MY	2015 MY
----------------	-------------------------	-------------------------	-------------------------	-------------------------	-------------------------	-------------------------

3. REMOVE THE AIRBAG FROM THE DASH

- a) Remove the 3 screws and the side defroster nozzle.
- b) Remove the 2 screws and the heater to register duct.

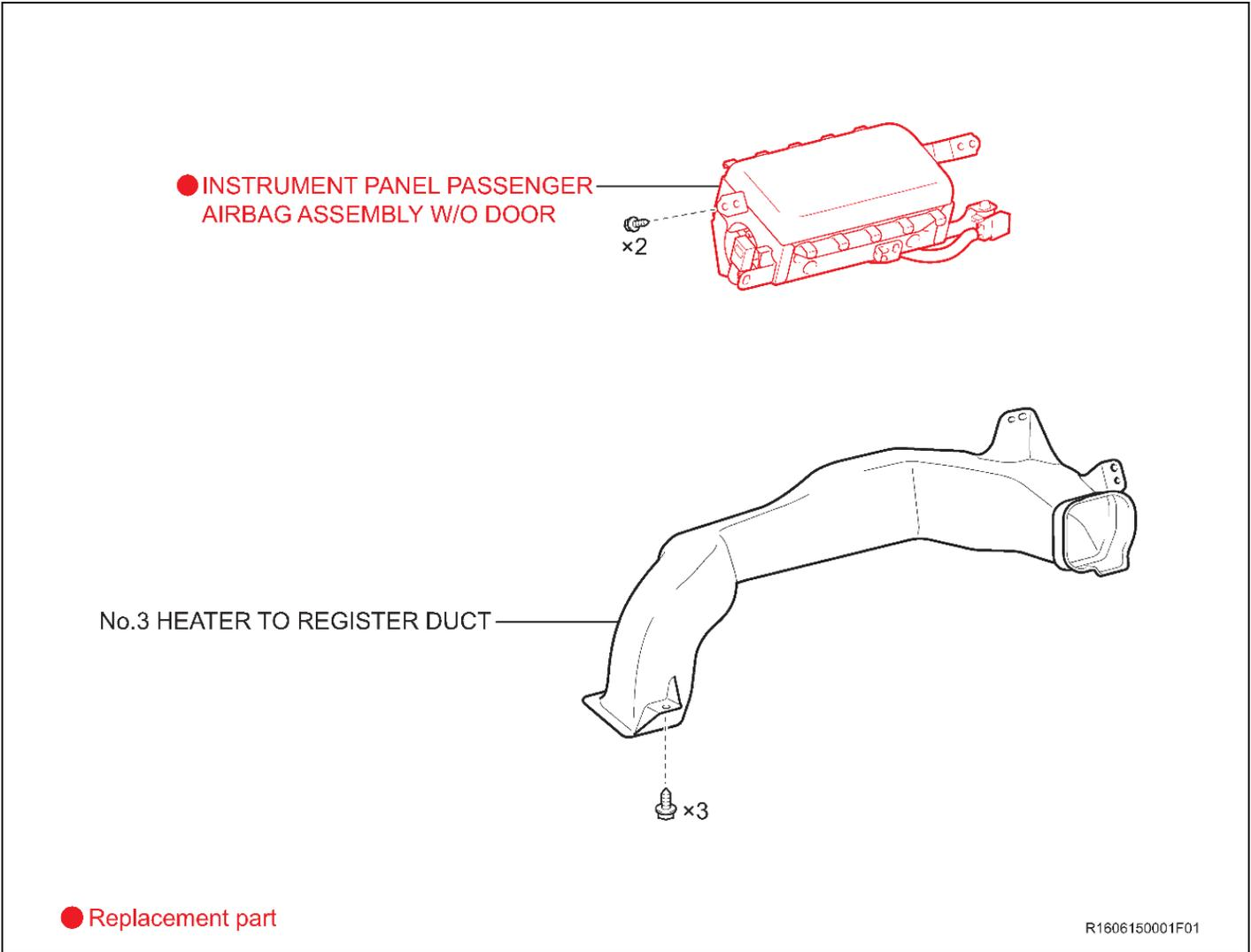

c) Remove the 4 bolts, disengage the straps, and then remove the airbag assembly.

NOTE: Use a screwdriver with the tip wrapped in tape to remove the airbag from the dash.

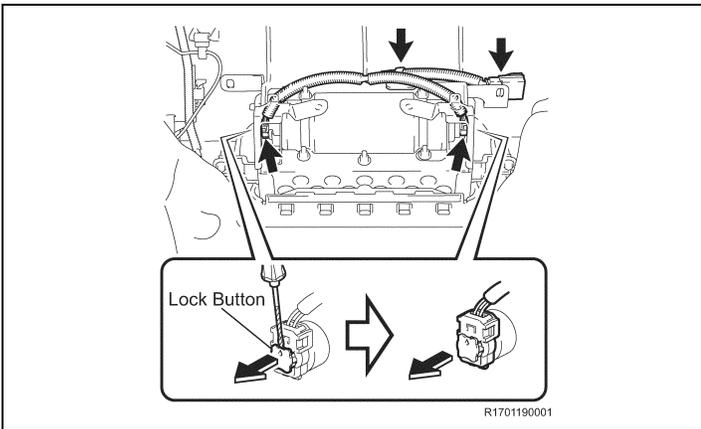
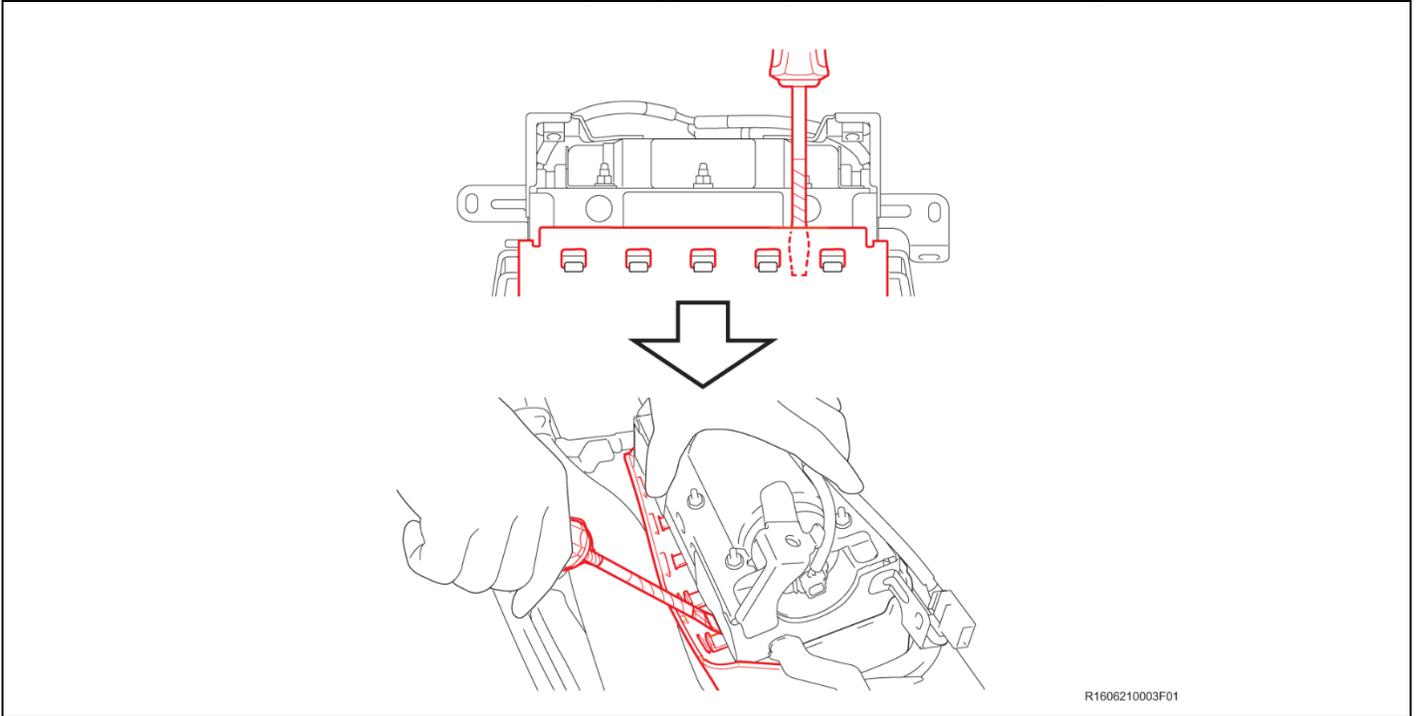

d) Using a screwdriver to release the lock button of the connector.

e) Disconnect the 2 connectors.

f) Disengage the 2 clamps.

NOTE: The removed instrument panel wire will not be reused.

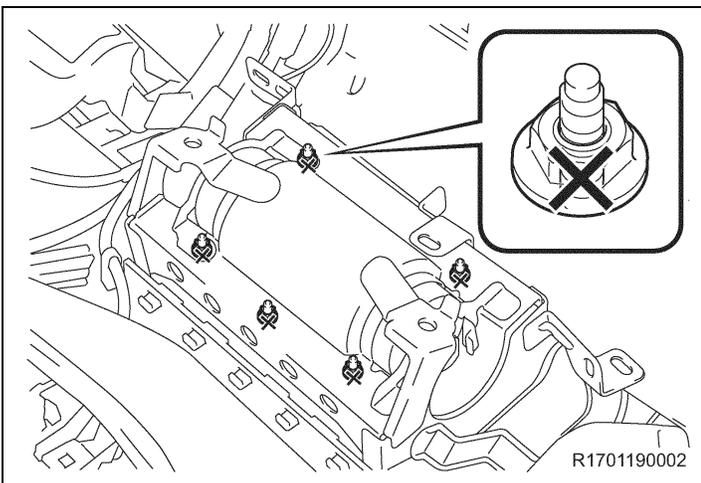

1. REMOVE THE INFLATOR

a) Mark the 5 self locking nuts to prevent reuse.



b) Mount the adaptors (579943-3R3) to the airbag as shown.

NOTE: The 6mm stud mounts to the airbag.



c) Mount the airbag to the mounting bracket as shown.

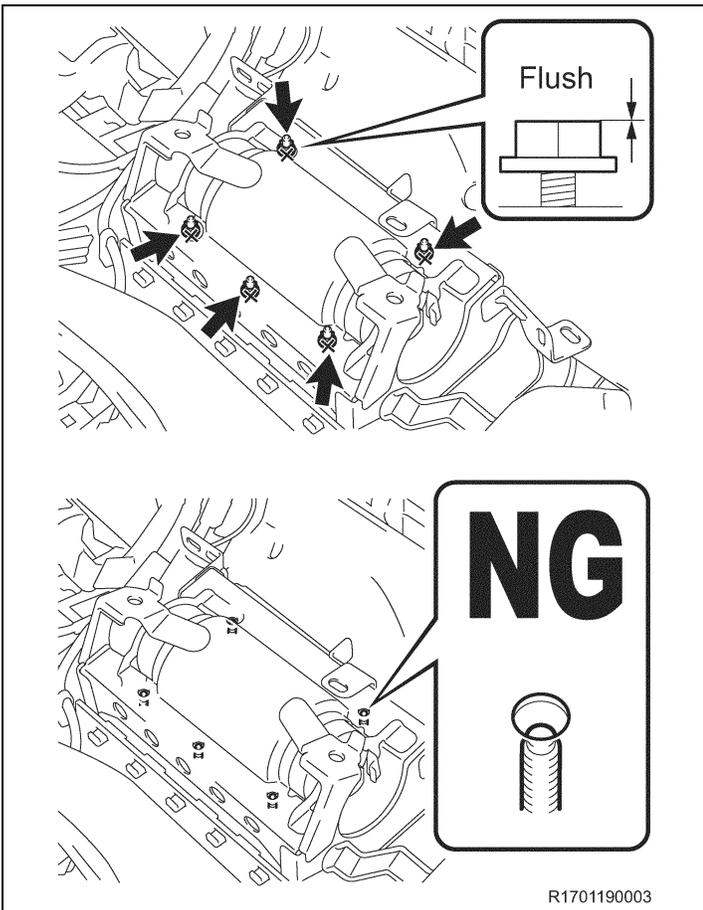

d) Loosen the 5 nuts until each nut is flush with the top of the stud as shown.

NOTE: You may need to slide the airbag to the left or right to access the middle nut. DO NOT use power tools to remove the nuts.

R1701190003

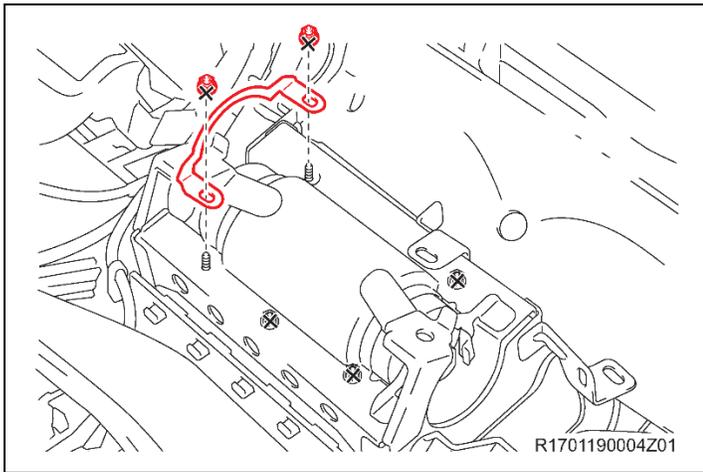

- e) Loosen and discard the 2 nuts on the end where the positioning plate is removeable.
- f) Remove and discard the plate.

NOTE:
DO NOT use power tools.

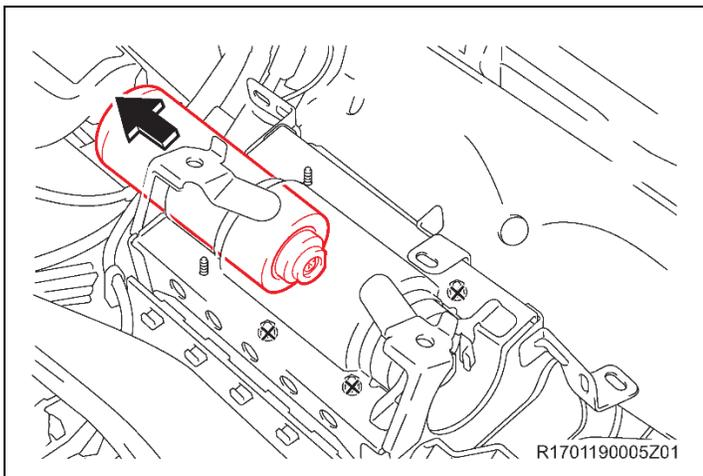

- g) Remove the inflator.

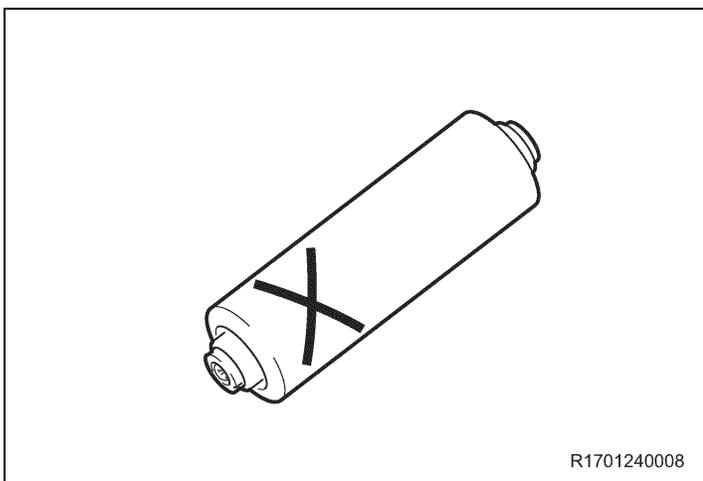

- h) Mark the old inflator so it is not reused.
- NOTE: Return the old inflator to the parts department for recovery.**

VIII. AIRBAG AND INFLATOR RECORDING

1. LAUNCH THE SERIAL NUMBER RECORDING APPLICATION



- The serial numbers **MUST** be recorded using a barcode scanner (provided at the launch of SSC DLC).
- The barcode scanner application **MUST** be completed on every vehicle. These numbers **MUST** be included on every warranty claim that is submitted for airbag inflator replacement or the claim may be subject to debit.
- The technician performing the work **MUST** have valid TIS login credentials and an internet connection to perform the inspection and scanning process.

- a) Log in to TIS and input the VIN of the vehicle in the Vehicle Inquiry tab.
- b) Confirm the VIN is applicable and that the campaign has not been completed.
- c) Click on the link to be sent to the scanning application site.
- d) You can also log into the scanning site via the URL below

Log into the website via the URL below

<https://takata-scan-app.imagespm.info/>

User ID: Dealer Code

First time login password: xxxxx

The screenshot displays the Toyota TIS Vehicle Inquiry interface. At the top, navigation tabs include Home, TIS, TAS, PRS, and QAT. The 'Vehicle Inquiry' tab is active. Below the navigation, there are tabs for Library, Diagnostics, Tech Assistance, and Vehicle Inquiry. The 'Vehicle Identification Number Search' section contains a text input field with the VIN '1NX-BR32E-000000000' and 'Clear' and 'Lookup' buttons. A red circle highlights the VIN input field, labeled 'a)'. Below this is the 'Vehicle Information' section, which displays details for a 2003 Toyota Corolla CE, 4-door sedan, 2WD, produced on 01/18/2002. The VIN '1NX-BR32E-000000000' is listed. Below the vehicle information are tabs for Campaign, Service History, Warranty, DTC History, and Diagnostic Report. The 'Service Campaign' section shows a campaign description: 'Safety Recall DOF Remedy Notice - 2003-2004 Model Year Corolla, Corolla Matrix, Sequoia, and Tundra Vehicles, 2002-2003 Model Year Vehicles Front Passenger Airbag Inflator Module'. The 'Completion Status' is 'Not Completed' and 'Check applicability for VIN'. A red circle highlights the 'Not Completed' status, labeled 'b)', and another red circle highlights the 'Check applicability for VIN' link, labeled 'c)'. The footer of the page includes '© 2013 Toyota Motor Sales, Inc.' and 'Feedback | Privacy | Legal'.

Login

Complete all required (*) fields below.

*** User ID (enter your 5-digit dealer code, or 6-digit for Canadian dealers eg. Cnnnnn format):**

*** Password:**

Login

[Forgot Password?](#)

Technician Information

Please provide information below before searching for VIN.

Technician Name:

SPIN ID (12 digit code):

Search

a) Enter your name and SPIN ID into the site

Enter VIN

Enter the 17-digit Vehicle Identification Number to begin the search for this campaign.

VIN:

Mileage on Vehicle:

Search

b) Enter the VIN and vehicle mileage into the site

2. CONNECT THE BARCODE SCANNER

- Connect the barcode scanner to the USB port on the Techstream.
- The scanner will automatically connect and a beep will be heard when the scanner is ready.

NOTE:

- **The scanner was provided for SSC DLC.**
- **The barcode scanner works best in low light conditions.**
- **Always hold the scanner directly in front of and parallel to the barcode label.**

3. SCAN THE AIRBAG SERIAL NUMBER

ATTENTION: This information is **CRITICAL**

- a) Scan the **AIRBAG ASSEMBLY** serial number 2 times.
 - 1) Confirm the cursor is in the first serial number box then scan the serial.
 - 2) Position the cursor in the second serial number box then scan the serial.
- b) Click next.

NOTE:

- If both serial numbers that are entered do not match, confirm and reenter.
- If the serial number barcode will not scan, it can be entered manually.

AIRBAG SERIAL NUMBER IDENTIFICATION

- The airbag serial number is **ALWAYS** the **12 DIGITS** located between the asterisks.
- The 3 digits before the asterisk **ARE NOT** part of the serial number, and **SHOULD NOT** be entered or an inaccurate response may be returned.

Airbag Serial Number Label Example



The **AIRBAG ASSEMBLY** serial number and the **INFLATOR** serial number are **DIFFERENT**. The **AIRBAG ASSEMBLY** serial number **MUST** be recorded prior to replacement.

ORIGINAL Airbag Assembly Serial Number

Scan or enter the **original** Airbag Assembly serial number into the website.

VIN:
Model / Campaign:

* Serial Number of *Original* Airbag Assembly:

* Re-confirm the Serial Number of *Original* Airbag Assembly:

Check if the airbag serial number is missing or not visible, or if installing a new airbag assembly

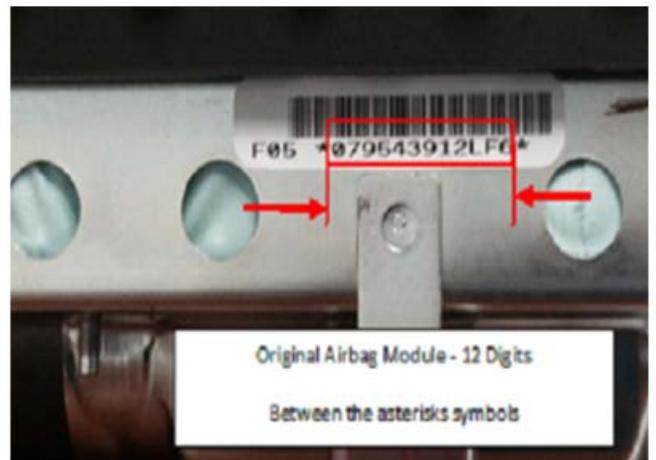

AIRBAG SERIAL NUMBER IS MISSING OR IS UNREADABLE



If the airbag serial number and barcode are not legible or are not present, check the box in the application indicating the serial number is not legible and contact your regional representative.

a) If the airbag serial number cannot be scanned or is not present check the box as shown below.

ORIGINAL Airbag Assembly Serial Number

Scan or enter the *original* Airbag Assembly serial number into the website.

VIN:
Model / Campaign:
* Serial Number of *Original* Airbag Assembly:
* Re-confirm the Serial Number of *Original* Airbag Assembly:
 Check if the airbag serial number is missing or not visible, or if installing a new airbag assembly
Search

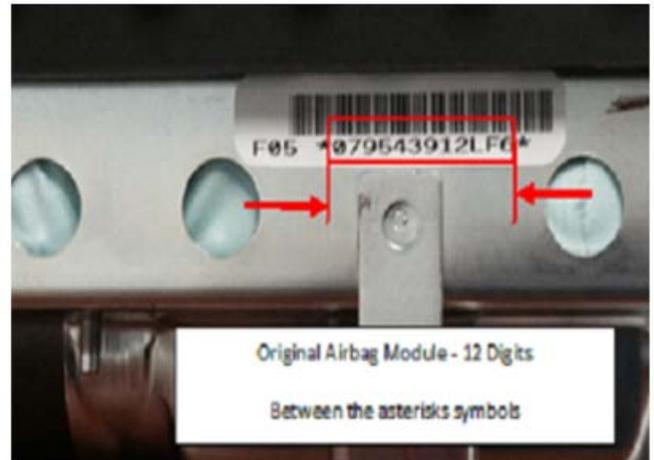

Checking this box requires Air Bag Assembly replacement.

****Note** Contact your region in the event that you are unable to read the serial number.**

DO NOT ATTEMPT TO INSTALL INFLATOR

b) After the Region approves the Airbag Assembly replacement and the new part is received, scan the NEW airbag barcode in the Serial Number Recording Application.

NEW Serial Number

Scan or enter the **new** Airbag Assembly Serial Number into the website.

VIN:

* Serial Number of New Airbag Assembly:

* Re-confirm the Serial Number of New Airbag Assembly:

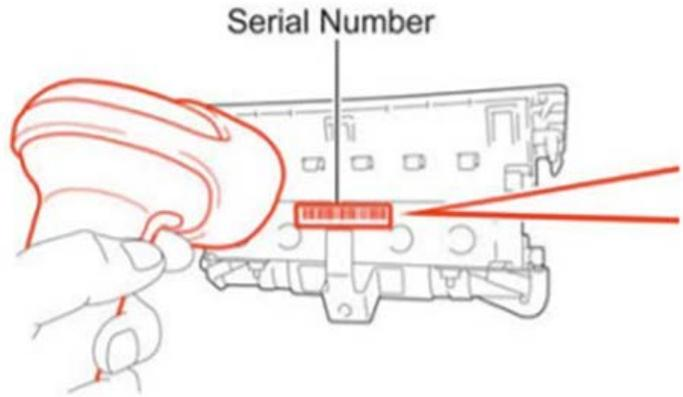

The new **AIRBAG ASSEMBLY** serial number **MUST** be recorded prior to reinstallation to track the airbag assembly to the vehicle.



**ENSURE YOU ENTER BOTH THE OLD AND NEW INFLATOR SERIAL NUMBER IN THE APPROPRIATE SPOT OF THE APPLICATION
-DO NOT ENTER THE AIRBAG SERIAL NUMBER FOR THIS STEP-**



1. SCAN THE OLD AND NEW INFLATOR SERIAL NUMBER

- a) Scan the **OLD** inflator serial number and mark the old inflator so that it will not be reused.
- b) Scan the **NEW** inflator QR code.

ATTENTION: This information is CRITICAL

- It is used to confirm the correct inflator is removed from the vehicle.
- It is recorded by TMS to trace the return parts shipment.
- It is used to track the new inflator that is being installed in the vehicle.

ORIGINAL Inflator Serial Number

Scan or enter the **original** Inflator serial number into the website.

VIN: 2T1BR32E57C810829
 Model / Campaign: 2007 Corolla / E04

* Serial Number of *Original* Inflator:

* Re-confirm the Serial Number of *Original* Inflator:

Check if the inflator serial number is missing or not visible, OR if installing a new airbag assembly

Search



REPLACEMENT Inflator Serial Number

Scan or enter the **replacement** Inflator serial number into the website.

VIN: 2T1BR32E57C810829
 Model / Campaign: 2007 Corolla / E04

* Serial Number of *Replacement* Inflator:

* Re-confirm the Serial Number of *Replacement* Inflator:

Search



c) If the inflator serial number cannot be scanned or is not present check the box as shown below.

ORIGINAL Inflator Serial Number

Scan or enter the **original** Inflator serial number into the website.

VIN: 2T1BR32E57C810829
Model / Campaign: 2007 Corolla / E04

* Serial Number of *Original* Inflator:

* Re-confirm the Serial Number of *Original* Inflator:

Check if the inflator serial number is missing or not visible. OR if installing a new airbag assembly



Checking this box requires Air Bag Assembly replacement.

****Note** Contact your region in the event that you are unable to read the serial number.**

DO NOT ATTEMPT TO INSTALL INFLATOR

d) Confirm agreement by checking the two boxes.

e) Record the Warranty Authorization # to be included in the warranty claim.

f) Place the old inflator in the parts box and take it immediately to the parts department.

NOTE:

- Confirm the cursor is in the correct serial number input box before scanning.
- If the serial number barcode will not scan, it can be entered manually.
- If there are any difficulties or concerns with this process, email quality_compliance@toyota.com with details.

Step e)

Takata Scan App (TEST v2) Final Results

You can [Print Screen](#) or [Search Another VIN](#).

Results:	Inflator Replacement Required
Warranty Authorization Number:	77515K46 <small>This number is required for the warranty claim. Print and save this screen for your records</small>
VIN:	2T1BR32E57C810829
Vehicle:	2007 Corolla
Campaign:	E04
Original Airbag Serial:	123456789K12
Replacement Airbag Serial:	
Original Inflator Serial:	W0123456789
Replacement Inflator Serial:	W0123456789
Scan Date:	12/22/2020 08:47AM (mm/dd/yyyy)

IX. VEHICLE REASSEMBLY

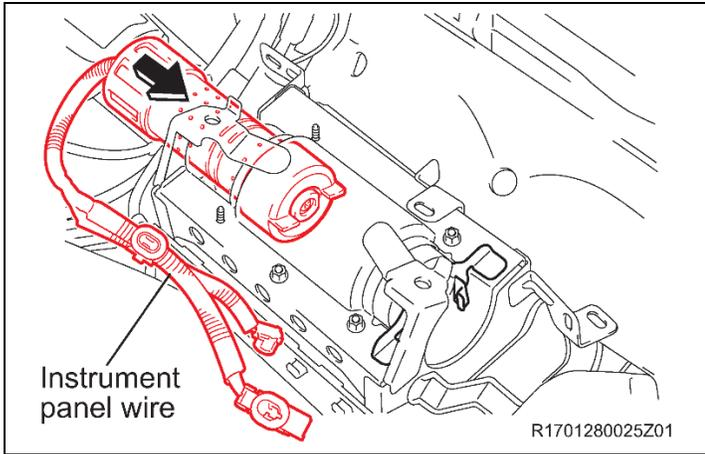

1. INSTALL THE NEW INFLATOR

a) Install the new inflator as shown.

b) Ensure that the inflator is oriented in the correct position as shown.



- Make sure the inflator is correctly positioned.
- The inflator cannot be fully inserted if it is upside down.

Check orientation

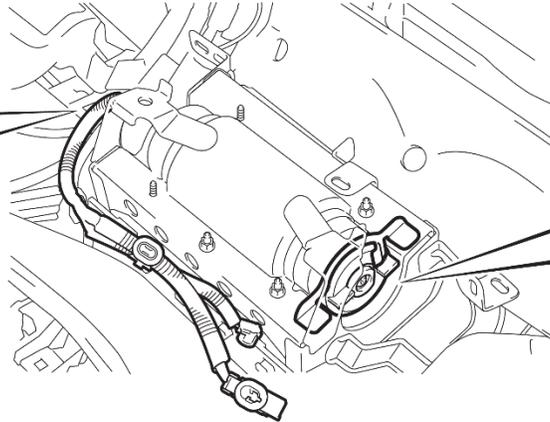
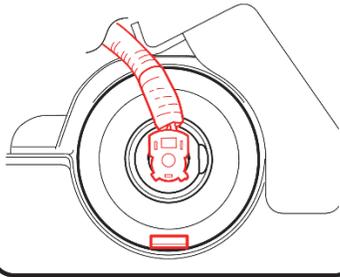

Check orientation

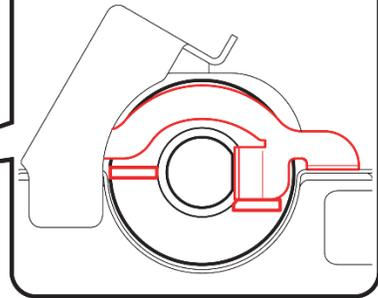

R1701280026Z01

Install temporarily
by hand.

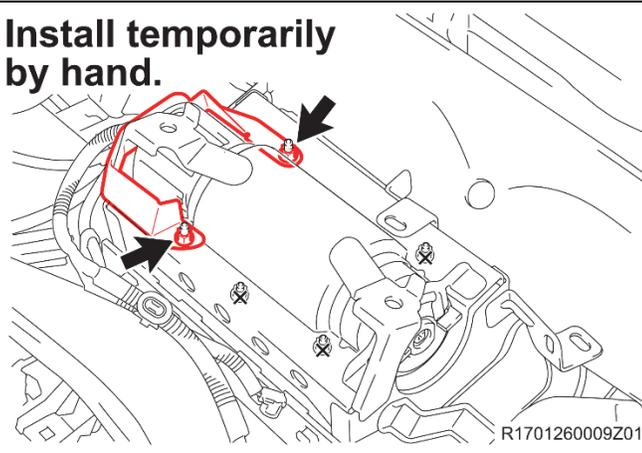

- Install the **NEW** positioner plate.
- Temporarily install 2 **NEW** nuts.

**Install temporarily
by hand.**

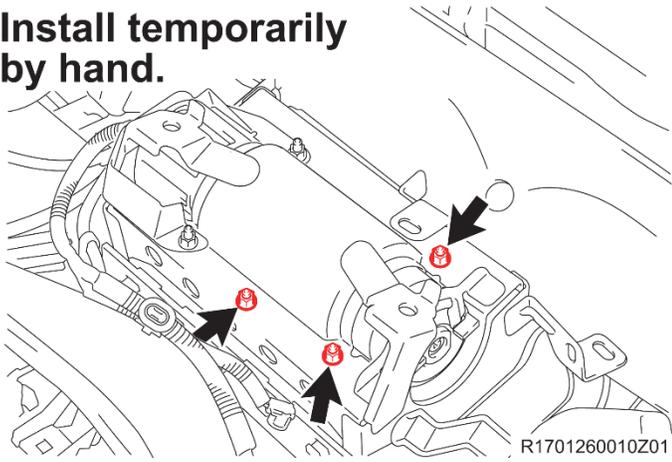

- c) Remove and discard the 3 remaining nuts.
- d) Temporarily install 3 **NEW** nuts.

e) Push the inflator towards the position determining plate and eliminate any gaps.

STOP

- If any gaps exist, the flats may move apart and could result in abnormal operation during airbag deployment.

**(a) Replacement
of parts.**

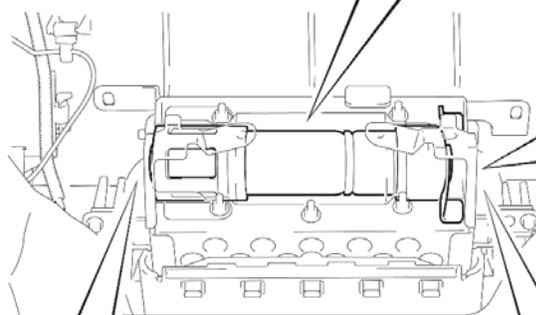
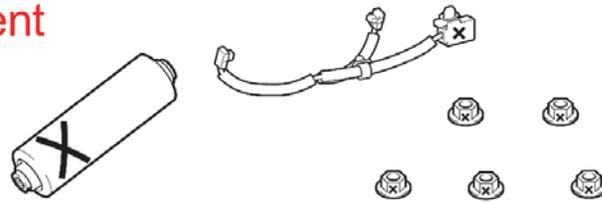

(b) No gap.

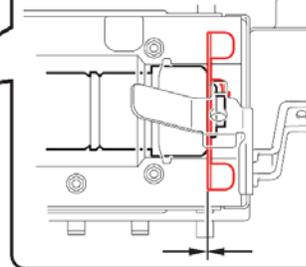

(b) Check orientation.

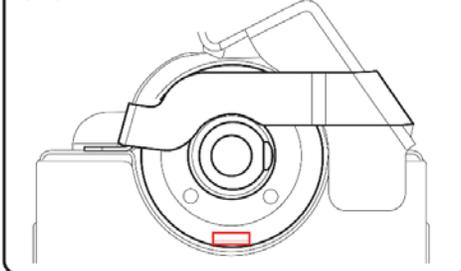

(b) Check orientation.

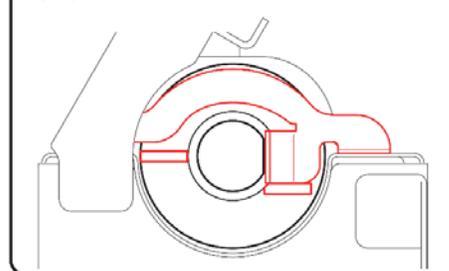

R1701260003Z01

f) Tighten the 5 nuts evenly in several increments in the sequence shown. Use a socket driver or torque wrench to tighten the nuts.

Torque: 35 in. lbf (3.9N·m)



- There will be some resistance when tightening the nuts because they are self-locking, confirm the nuts are tightened correctly.
- **DO NOT** use a power tool, T-handle, or ratchet when tightening the nuts to avoid over torqueing and deforming the studs.
- You may need to slide the airbag to the left or right with in the mounting bracket to access the center nut.

OK

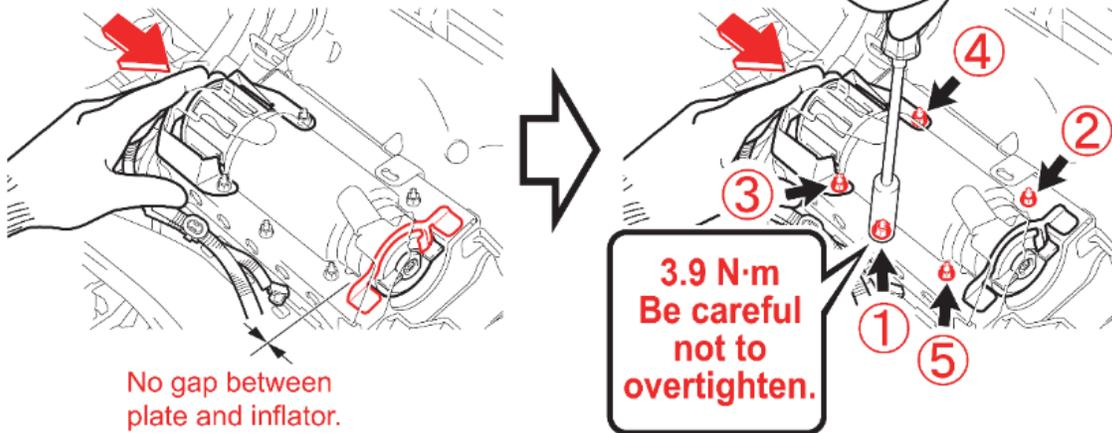

NG

NG

NG



These tools cause overtightening !

R1701260011Z01

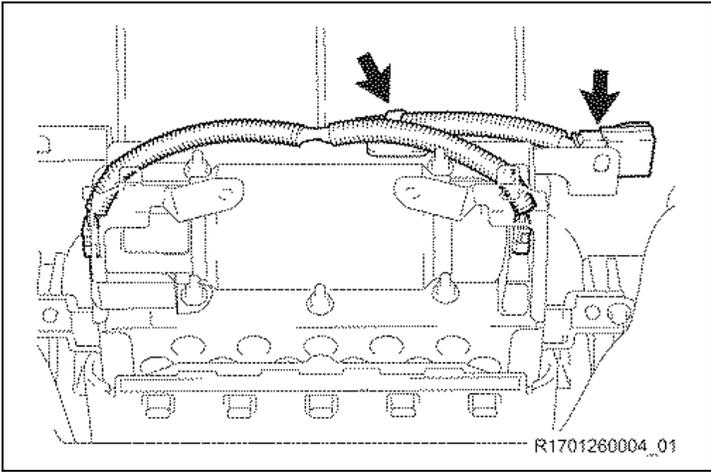

g) Engage the 2 clamps for the new wire harness.

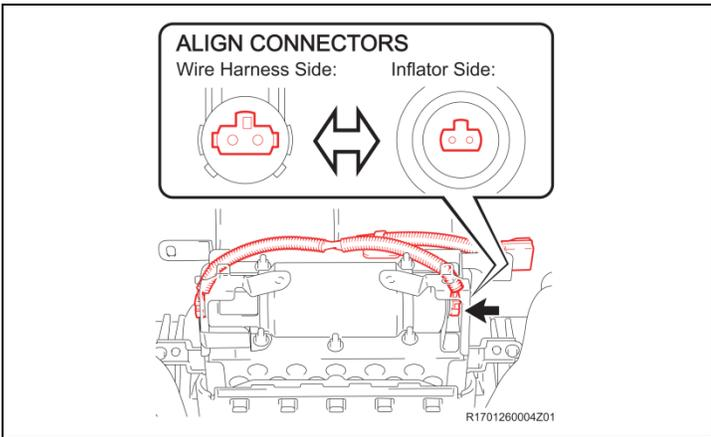

h) Connect the connector and the secondary lock.

NOTE: Ensure that the connector is securely connected.

2. REINSTALL THE AIRBAG ASSEMBLY INTO THE INSTRUMENT PANEL

- a) Position the airbag assembly in the instrument panel, engage the straps, and then install the 4 bolts.



- The bolts do NOT need to be replaced. Reinstall the original bolts

NOTE: Ensure the airbag connectors is positioned as shown

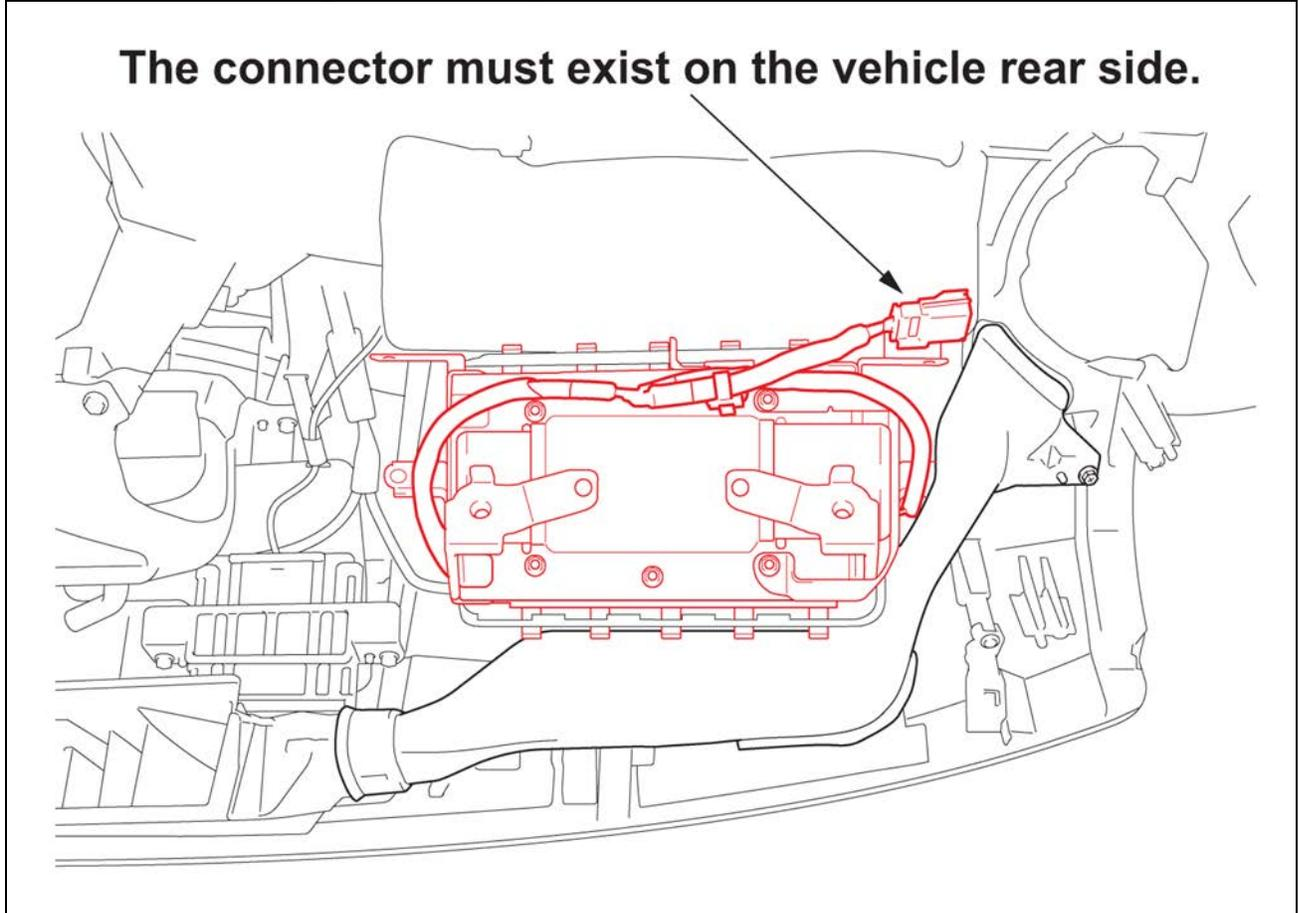

- b) Install the 2 screws and the heater to register duct.
c) Install the 3 screws and the side defroster nozzle.

3. REINSTALL THE DASH

- a) Refer to TIS for reinstallation instructions

IS Convertible	2010 MY	2011 MY	2012 MY	2013 MY	2014 MY	2015 MY
----------------	-------------------------	-------------------------	-------------------------	-------------------------	-------------------------	-------------------------

4. RECONNECT THE NEGATIVE BATTERY CABLE
5. PERFORM A HEALTH CHECK AND DIAGNOSTIC REPORT
6. PERFORM ANY NEEDED SYSTEM INITIALZATIONS

◀ VERIFY REPAIR QUALITY ▶

- Confirm all precautions are followed to ensure safety during the repair
- Confirm the entire serial number checker application is completed and the warranty authorization # is recorded on *EVERY* vehicle
- Confirm the old inflator is handled safely and given to the appropriate parts professional for shipment

If you have any questions regarding this update, please contact your area representative.

X. APPENDIX

A. CAMPAIGN DESIGNATION DECODER

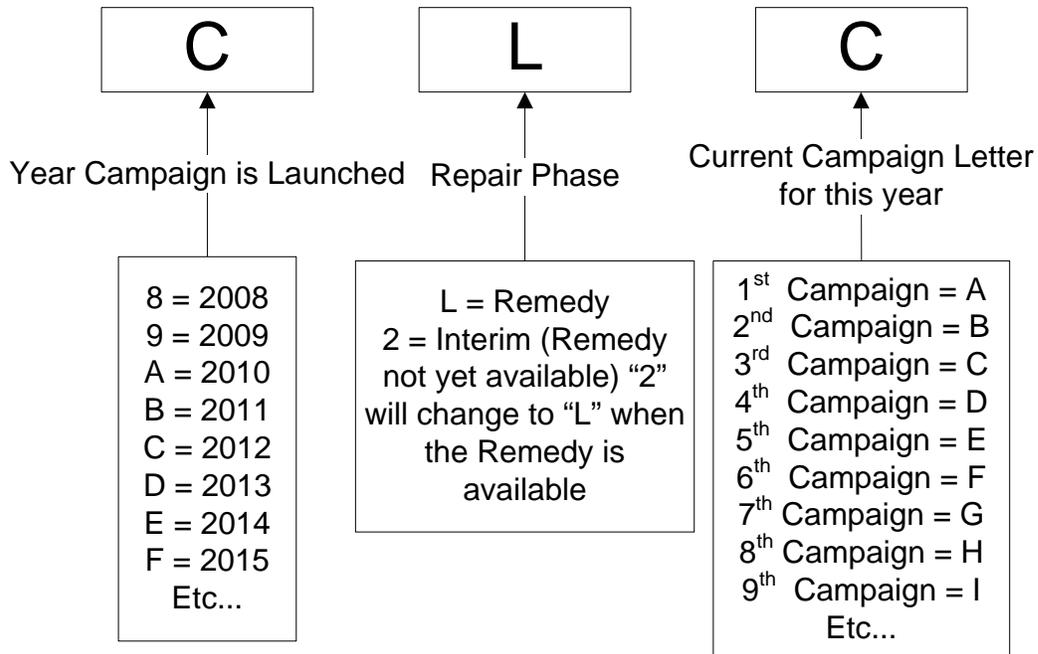

B. CAMPAIGN PARTS DISPOSAL

ALL airbags that are removed from vehicles under this campaign **MUST** be packaged and shipped back to the manufacturer following the manufacturer's instructions. The instructions can be found in the following locations:

- Attached to the dealer letter
- Included in the parts box