



SAFETY RECALL NOTICE

VOLVO CAR USA LLC
PO Box 3757, Highland Park, MI 48203-9984

PRESORT
FIRST-CLASS
U.S. POSTAGE
PAID
VOLVO CAR



YV9AC9HL9K9999999 R89978A010920 525358-01 1

Volvo Owner
12345 USin St.
Any City, US 12345-6789



IMPORTANT SAFETY RECALL INFORMATION



Issued in Accordance
With Federal Law



January 24, 2020

NHTSA RECALL 19V849

IMPORTANT SAFETY RECALL

THIS NOTICE APPLIES TO YOUR VEHICLE, VIN: YV9AC9HL9K9999999

Dear Volvo Owner,

This notice is sent to you in accordance with the requirements of the National Traffic and Motor Vehicle Safety Act.

Volvo Car USA LLC (Volvo) on behalf of Volvo Car Group, has decided that a defect which relates to motor vehicle safety exists in certain model year 2011 – 2017 S60, V60, S60CC, S60I, V60CC vehicles.

The reason for Recall R89978:

Volvo has identified that vehicle exposure to hot climate conditions over time, can cause the door latch to weaken and the retention hook for pawl spring in the side door latch to break. This can make the doors difficult to latch, or lead the driver/passenger to believe the door is securely closed when it is not.

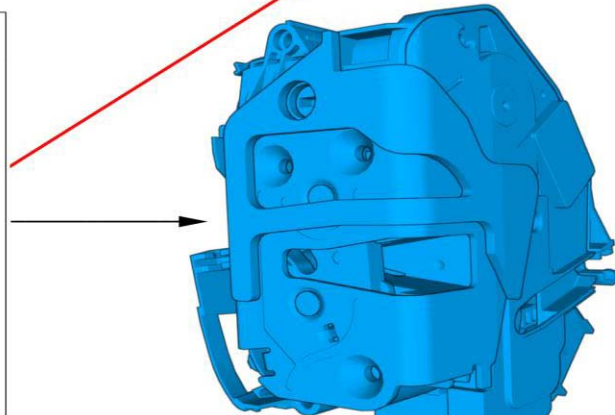

A door that is not securely latched could open while the vehicle is in motion, increasing the risk of injury to a vehicle occupant.

The corrective action is to replace all four (4) door latches in both front and rear side doors with new improved door latches, free of charge.

Unfortunately at this time, replacement parts are not available for this repair. Please be assured that Volvo is working to secure the needed replacement door latches as soon as possible. We will send you a second notification letter as soon as the replacement door latches are available.

What should you do now?

In the majority of the cases, you will experience difficulty in closing the door if there is an issue with the door latch.

However, if the driver/passenger does not notice that the door is bouncing / not latching, the open-door warning (AJAR switch) light will illuminate in the Driver Information Module (DIM).

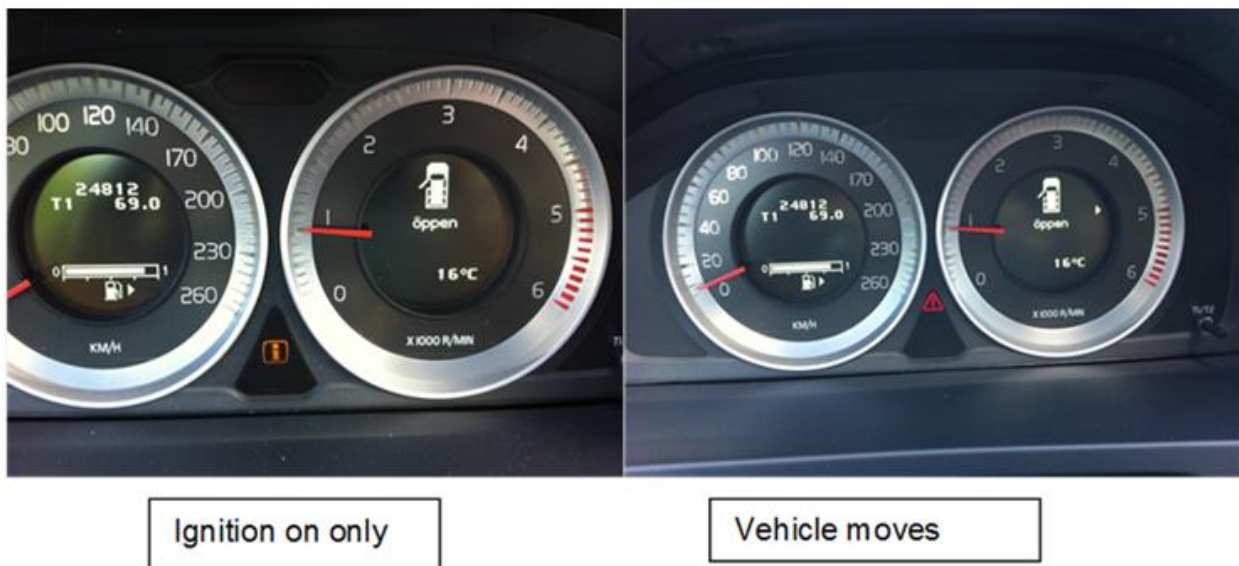

If the vehicle does not exhibit any of the above conditions, the vehicle is ok to operate.

Seat belts should always be worn by all occupants in your vehicle. Children should be properly restrained using an infant seat, adjustable child seat or booster cushion as determined by age, weight and height.

If you no longer own the vehicle described in this letter, please help us to update our records by sending us the updated owner information. Please refer to our contact information in this letter.

Please contact:

If you have any questions, please contact your Volvo retailer. If your retailer is unable to answer your questions, please contact Volvo Customer Care Center:

1 Volvo Drive,
P.O. Box 914,
Rockleigh, NJ 07647

Or by phone at 1-800-458-1552, 24 hours a day, 7 days a week. You may also contact us by going to <http://volvocars.us/support>.

We have advised the National Highway Traffic Safety Administration (NHTSA) that we are conducting this recall. If you are unable to have this procedure performed without charge, and within a reasonable period of time, you may contact the NHTSA Administrator at:

National Highway Traffic Safety Administration
1200 New Jersey Avenue, SE.
Washington, DC 20590

Or you can call the toll-free Vehicle Safety Hotline at 1-888-327-4236 (TTY: 1-800-424-9153). You may also go to their website, <http://www.safercar.gov>.

Federal law requires that any vehicle lessor receiving this recall notice must forward a copy of this notice to the lessee within ten days.

Your safety and continued satisfaction with your Volvo and the Volvo organization are very important to us. We apologize for any inconvenience this may cause, and we are working to have this important service completed as quickly as possible.

Sincerely,

A handwritten signature in black ink that reads "Jason Guidi". The signature is written in a cursive style with a large initial "J" and "G".

Jason Guidi
Director - Regulatory & Compliance
1-800-458-1552

