



TAP Worldwide, LLC d/b/a/ Transamerican Auto Parts
400 West Artesia Boulevard
Compton, California 90220 USA
1-800-776-0767 ext. 1717

IMPORTANT SAFETY RECALL

This notice applies to extended thread lug nuts, part numbers PXA16148; PXA16148B; and PXA16148OET.

This notice is sent to you in accordance with the National Traffic and Motor Vehicle Safety Act.

Date: November 27, 2019

Dear Valued TAP Customer,

REASON FOR NOTICE

TAP Worldwide, LLC has decided that a defect which relates to motor vehicle safety exists in TAP Worldwide, LLC extended thread lug nuts. The particular extended thread lug nuts, due to their diameter, may not seat properly when used with certain aftermarket wheel brands and models.

Specifically, if the subject extended thread lug nuts were used in connection with certain wheel models that featured smaller diameter lug nut holes, the lug nuts may interfere with the lug nut hold, failing to retain torque, which could potentially allow the wheel to come loose or detach from the vehicle, resulting in a crash.

WHAT SHOULD YOU DO

You should contact TAP Worldwide, LLC's Recall Parts Assistance Department at 1-800-776-0767 ext. 1717 or by email at recallpartsassistance@4wp.com immediately for a replacement part or to identify a recommended service facility that is closest to you. You may replace the part yourself, or take your vehicle to a TAP Worldwide, LLC service facility or your own service facility for repair. TAP Worldwide, LLC will remedy the defect without charge and at no cost to the customer.

PARTS INFORMATION

The replacement part will be available through TAP Worldwide, LLC by contacting the Recall Parts Assistance Department at 1-800-776-0767 ext. 1717 or by email at recallpartsassistance@4wp.com.

WHAT WE WILL DO

If you choose to have a service facility do the repair, the service facility will replace the defective extended thread lug nuts with replacement, smaller diameter lug nuts that will address the risk of the lug nuts interfering with the lug holes on the wheel models at issue. A detailed description of each step required to correct the defect is provided as an enclosure.

HOW LONG WILL IT TAKE

The time needed for the replacement is approximately 0.75 hours. The service facility may need your vehicle for a longer period of time due to service scheduling issues, but every effort will be made to minimize your inconvenience.

REIMBURSEMENT

If you have already paid for repairs to address the condition covered by this recall, you may be eligible to have those costs reimbursed. Requests for reimbursement may include parts, labor, fees and taxes; however, it may not include any expense or inconvenience you may have suffered due to the loss of use of your vehicle. Reimbursement may be limited to the amount the repair would have cost if completed by an authorized service facility.

To be eligible for reimbursement:

- You must have had the part repaired before receiving this notice.
- You must have owned the vehicle at the time of repair. You are still eligible if you no longer own the vehicle.

Your claim will be acted upon within 60 days of receipt. If your claim is:

- Approved – you will receive a check.
- Denied – you will receive a letter with the reason(s) for denial.
- Incomplete – you will receive a letter identifying the required documentation needed to complete the claim and be offered the opportunity to resubmit the claim when the missing documentation is available.

To file a claim for reimbursement please contact the Recall Parts Assistance Department toll free at 1-800-776-0767 ext. 1717 or by email at recallpartsassistance@4wp.com for processing.

Please be prepared to provide the following information:

- Name
- Address
- Email
- Phone Number
- Part Name and Number
- Date of Repair
- Requested Reimbursement Amount

The following documentation must be submitted with this form. Original or clear copy of all receipts, invoices and/or repair orders showing:

- Name and address of the person who paid for the repair
- The part name and number of the item that was repaired
- The 17-digit Vehicle Identification Number of the vehicle that was repaired (if applicable)
- The total cost of the repair expense that is being claimed
- Payment for the repair in question and the date of the payment

Failure to include proper documentation can delay your reimbursement. Alternatively, you may fill out the Claim Form enclosed in this notice and submit the required documentation by mail to

the address listed in the Contact Information section below. If you have questions, please call the Recall Parts Assistance Department toll free at 1-800-776-0767 ext. 1717.

CONTACT INFORMATION

If you have any questions regarding this matter, please contact us at 1-800-776-0767 ext. 1717.

If you have any problems obtaining the needed repair or believe that this repair has not been made within a reasonable time, you may contact us at 1-800-776-0767 ext. 1717, by email at recallpartsassistance@4wp.com, or by mail to:

TAP Worldwide, LLC
Attn: Recall Parts Assistance
400 West Artesia Boulevard
Compton, California 90220 USA

If, after contacting TAP Worldwide, LLC, you still have a problem getting this repair made within a reasonable time and/or without charge, you may submit a complaint to the Administrator, National Highway Traffic Safety Administration, 1200 New Jersey Ave., SE., Washington DC 20590; or call the toll-free Vehicle Safety Hotline at 1-888-327-4236 (TTY: 1-800-424-9153); or go to <http://www.safercar.gov>.

If you are a vehicle lessor, Federal law requires that any vehicle lessor receiving this recall notice must forward a copy of this notice to the lessee within ten days.

Your continued satisfaction with TAP is important to us. Please understand that we have taken this action in the interest of your safety and your vehicle's proper operation. We regret any inconvenience that this action may cause you.

Sincerely,

TAP Worldwide, LLC

Customer Reimbursement Claim Form

This section to be completed by the claimant

Date Claim Submitted: _____

Part Name and Number: _____

Date of Repair: _____

Claimant Name: _____

Street Address or PO Box Number: _____

City: _____ State: _____ Zip Code: _____

Claimant Email: _____

Telephone Number: _____

Amount of Reimbursement Requested: _____

The following documentation must be submitted with this form. Original or clear copy of all receipts, invoices and/or repair orders showing:

- Name and Address of the person who paid for the repair
- The part name and number of the item that was repaired
- The 17-digit Vehicle Identification Number of the vehicle that was repaired (if applicable)
- The total cost of the repair expense that is being claimed
- Payment for the repair in question and the date of the payment

By signing this document, you attest that the information provided on this form and all attached documents are genuine and that you request reimbursement for the expense incurred for the repair covered by this letter.

Claimant's Signature: _____

Please mail this claim form and the required documents to:

TAP Worldwide, LLC
Attn: Recall Parts Assistance
400 West Artesia Boulevard
Compton, California 90220 USA

Reimbursement questions should be directed to the Recall Parts Assistance Department at 1-800-776-0767 ext. 1717, or email at recallpartsassistance@4wp.com.

STEPS TO CORRECT

- 1.) Check Lugnut ET **Diameter** w/ Check Tool. If lugnut does not fit into hole in Check Tool, you cannot use Lugnut with wheel.



- 2.) Check Wheel lugnut **holes** from back side of wheel w/ Ck tool, *before* mounting tires on any new wheels. Make sure gage fits into All lug holes from back side of wheel (mounting pad). If tool does not fit into wheel lug holes, then you cannot use that/those wheels with ET lugnuts. NOTE: Wheel Lugnut thru holes are 16 mm nominal Diameter.



- 3.) Check lugnut ET **Length** w/ Ck tool. Confirm ET lugnut length is not too long. Also, confirm by hand and visually that lugnut mates properly with wheel *prior* to mounting tires on wheels. Lugnut needs at least approximately 1/16 inch (2 mm) air gap between wheel mounting pad and bottom of lugnut.



- 4.) Check ET Lugnut **Taper** w/ Ck tool. Lugnut taper should mate up flush with taper on Check Tool. If an air gap of greater than 0.5 mm exists, you cannot use lugnuts with wheels.



- 5.) Confirm Lugstud will not “bottom out” in lugnut before correctly clamping wheel. Check this by threading a lugnut onto the lugstud with the wheels removed from the vehicle. Check lugstuds on both front *and* back axles.

GENERAL NOTE: Use a wire brush to carefully clean off any rust or debris from lugstuds and/or axle hub boss before installing or test fitting any Accessory Wheel and/or ET lugnuts onto vehicle axles. If the wheel being inspected is a *used* wheel, carefully clean off the backside of the wheel and the wheel center bore section that mates up with the vehicle axle, before inspection.

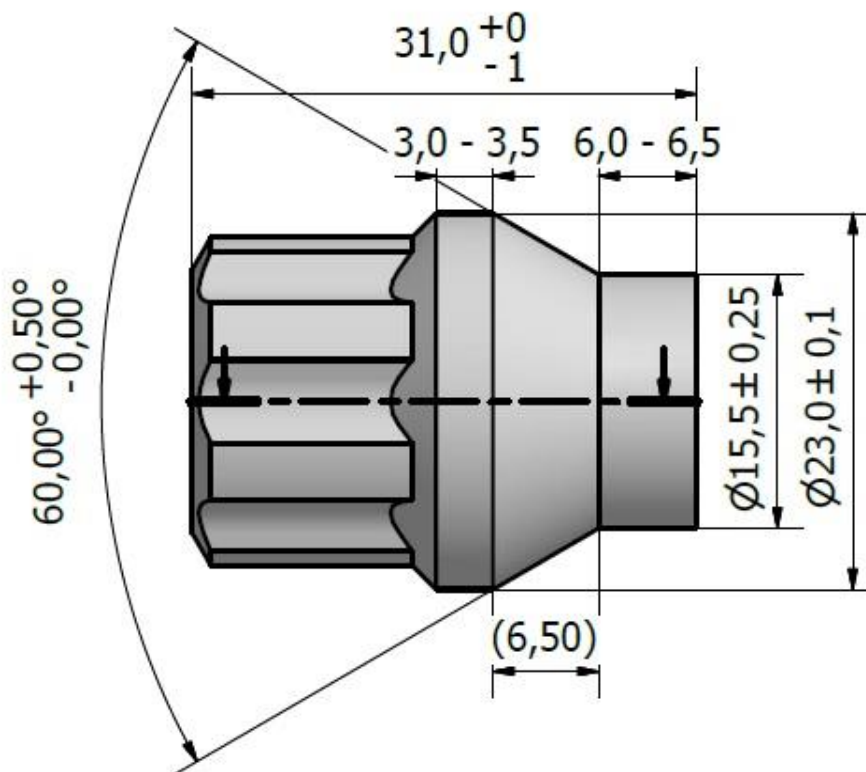

Example ET Lugnut
Recall No. 19E-060

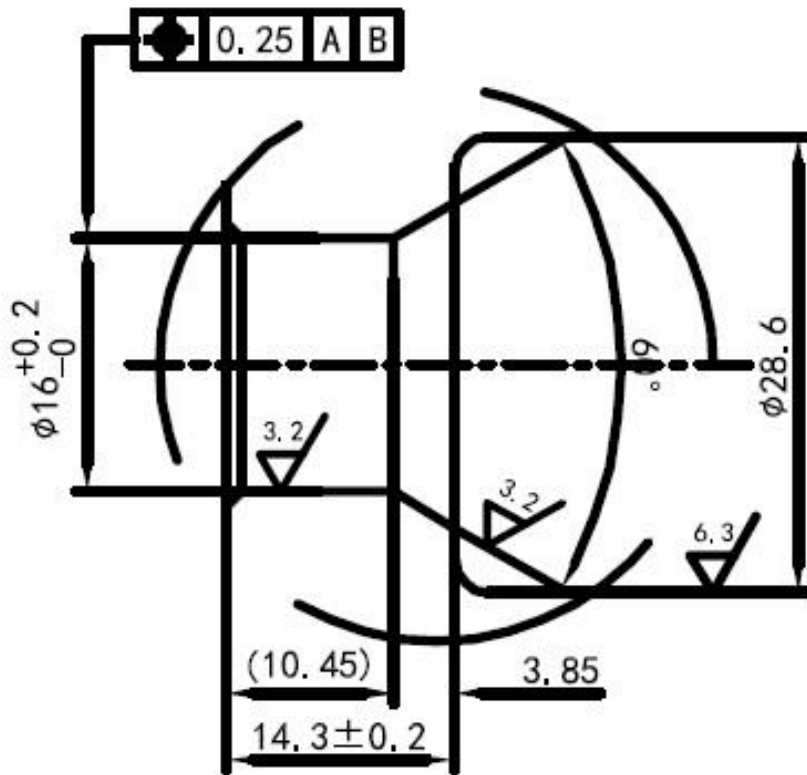

Example Wheel Hole Geometry