



David J. Johnson  
 Director  
 Service Engineering Operations  
 Ford Customer Service Division

Ford Motor Company  
 P. O. Box 1904  
 Dearborn, Michigan 48121

February 18, 2022

**TO:** All U.S. Ford and Lincoln Dealers

**SUBJECT:** **NEW VEHICLE DEMONSTRATION / DELIVERY HOLD - Safety Recall 19S17 – Supplement #3**  
 Certain 2011-2017 Model Year Explorer Vehicles  
 Rear Suspension Toe Link Replacement

**REF:** **NEW VEHICLE DEMONSTRATION / DELIVERY HOLD - Safety Recall 19S17 – Supplement #2**  
 Dated October 30, 2020

**REF:** **NEW VEHICLE DEMONSTRATION / DELIVERY HOLD**

- **Safety Recall 16S18 - Supplement #6** Dated February 18, 2022
- **Safety Recall 17S11 - Supplement #7** Dated February 18, 2022
- **Safety Recall 18S43 - Supplement #3** Dated February 18, 2022
- **Safety Recall 20S62 - Supplement #4** Dated February 18, 2022
- **Safety Recall 21S32 - Dated February 18, 2022**

**New! REASON FOR THIS SUPPLEMENT**

*An updated rear toe link design has been released.*

- **Service Action** – *Completing any of the Explorer Toe Link Programs will close the field service action on all affected programs.*
- **Attachment III Tech Instructions** – *The tech instructions have been updated with a new procedure.*
- **Claims Preparation and submission** – *Added notes indicating that the updated parts have to be used and that completing any of the Explorer Toe Link Programs will close the field service action on all affected programs.*
- **Labor Allowances** – *Updated labor operations to reflect the new service procedure.*
- **Parts Requirements** – *Updated the parts required.*
- **FSA Parts Inspection and Sign Off** – *Added section.*

**AFFECTED VEHICLES**

Vehicle	Model Year	Assembly Plant	Build Dates
Explorer	2011-2017	Chicago	May 17, 2010 through January 25, 2017
	2014 and 2017	Elabuga	March 26, 2014 through January 25, 2017
	2017	Valencia	August 31, 2016 through November 14, 2016

Affected vehicles are identified in OASIS and FSA VIN Lists.

**REASON FOR THIS SAFETY RECALL**

In all of the affected vehicles, frequent full suspension jounce and rebound travel on rougher roads may increase the bending stress on the rear suspension toe link(s), which may result in toe link fracture. A customer with a fractured toe link may experience noise, unusual vehicle handling

characteristics, or difficulty controlling the vehicle. A fracture of a toe link while driving increases the risk of a crash.

### **NEW! SERVICE ACTION**

Before demonstrating or delivering any new in-stock vehicles involved in this recall, dealers are to replace both rear suspension toe links **with latest level parts**, check alignment, and adjust rear toe. This service must be performed on all affected vehicles at no charge to the vehicle owner.

**NOTE: Safety Recall 19S17 includes vehicles that were previously repaired under Safety Recall 16S18 with a DB5Z-5A972-E or DB5Z-5A972-F toe link kit.**

- Vehicles repaired in 16S18 with a DB5Z-5A972-J or DB5Z-5A972-K toe link kit are not included in 19S17.
- Any unrepaired vehicles in 16S18 will remain in 16S18 and are not included in 19S17.

**NOTE: Some vehicles in Safety Recall 19S17 were previously included in Optional Product Improvement Program 17G01, which has expired.**

- Any vehicles that were not repaired under 17G01 are included in 19S17 and will require rear suspension toe link replacement.
- Any vehicles that were repaired under 17G01 are not included in 19S17 and do not require rear suspension toe link replacement.

**NOTE: Some of the affected vehicles are also included in one or more of the following field service actions: 16S18, 17S11, 18S43, 20S62, or 21S32. If affected, the Ford system will automatically close all of these programs upon claim payment of any of the listed programs.**

### **OWNER NOTIFICATION MAILING SCHEDULE**

Owners of affected vehicles were notified in four separate mailings. Mailing were sent the week of June 24, 2019. Dealers should repair any affected vehicles that arrive at their dealerships, whether or not the customer has received a letter.

### **PLEASE NOTE:**

**Federal law requires dealers to complete this recall service before a new vehicle is delivered to the buyer or lessee. Violation of this requirement by a dealer could result in a civil penalty of up to \$21,000 per vehicle. Correct all vehicles in your new vehicle inventory before delivery.**

### **New! ATTACHMENTS**

- Attachment I: Administrative Information*
- Attachment II: Labor Allowances and Parts Ordering Information*
- Attachment III: Technical Information*
- Attachment IV: Use of Aftermarket Ball Joints/Bushings*

Owner Notification Letters  
Recall Reimbursement Plan

### **QUESTIONS & ASSISTANCE**

For questions and assistance, contact the Special Service Support Center (SSSC) via the SSSC Web Contact Site. The SSSC Web Contact Site can be accessed through the Professional Technician Society (PTS) website using the SSSC link listed at the bottom of the OASIS VIN report screen or listed under the SSSC tab.

Sincerely,

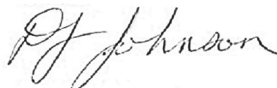

David J. Johnson

**NEW VEHICLE DEMONSTRATION / DELIVERY HOLD - Safety Recall 19S17 - *Supplement #3***

Certain 2011-2017 Model Year Explorer Vehicles  
Rear Suspension Toe Link Replacement

**OASIS ACTIVATION**

OASIS was activated on June 11, 2019.

**FSA VIN LISTS ACTIVATION**

FSA VIN Lists have been available through <https://web.fsavinlists.dealerconnection.com> since June 11, 2019. Owner names and addresses have been available since July 12, 2019.

**NOTE:** Your FSA VIN Lists may contain owner names and addresses obtained from motor vehicle registration records. The use of such motor vehicle registration data for any purpose other than in connection with this recall is a violation of law in several states, provinces, and countries. Accordingly, you must limit the use of this listing to the follow-up necessary to complete this recall.

**SOLD VEHICLES**

- Ford has not issued instructions to stop selling/delivering or driving used vehicles under this safety recall. Owners should contact their dealer for an appointment to have their vehicles remedied as soon as practicable. Owners can continue to safely drive their vehicles.
- Immediately contact any of your affected customers whose vehicles are not on your VIN list but are identified in OASIS. Give the customer a copy of the Owner Notification Letter (when available) and schedule a service date.
- Correct other affected vehicles identified in OASIS which are brought to your dealership.
- Dealers are to prioritize repairs of customer vehicles over repairs of new and used vehicle inventory.

**STOCK VEHICLES**

- Correct all affected units in your new vehicle inventory before delivery.
- Use OASIS to identify any affected vehicles in your used vehicle inventory.

**DEALER-OPERATED RENTAL VEHICLES**

The Fixing America's Surface Transportation (FAST) Act law effective June 2016 prohibits a rental company from selling, renting or leasing vehicles subject to a safety or compliance recall. Please consult your legal counsel for legal advice.

**TITLE BRANDED / SALVAGED VEHICLES**

Affected title branded and salvaged vehicles are eligible for this recall.

**NEW VEHICLE DEMONSTRATION / DELIVERY HOLD - Safety Recall 19S17- Supplement #3**  
Certain 2011-2017 Model Year Explorer Vehicles  
Rear Suspension Toe Link Replacement

**OWNER REFUNDS**

- **This safety recall must still be performed, even if the owner has paid for a previous repair. Claiming a refund will not close the recall on the vehicle.**
- Ford Motor Company is offering a refund for owner-paid repairs covered by this recall if the repair was performed prior to the date indicated in the reimbursement plan, which is posted with this bulletin. Owners are directed to seek reimbursement through authorized dealers or, at their option, directly through Ford Motor Company at P.O. Box 6251, Dearborn, MI 48121-6251.
- Dealers are also pre-approved to refund owner-paid emergency repairs that were performed away from an authorized servicing dealer after the end date specified in the reimbursement plan. Non-covered repairs, or those judged by Ford to be excessive, will not be reimbursed.
- Refunds will only be provided for the cost associated with rear suspension toe link replacement due to fracture *or wheel knuckle replacement due to a toe link ball joint that does not meet the outlined inspection criteria.*

**RENTAL VEHICLES**

Rental vehicles are not approved for this program.

**ADDITIONAL REPAIR (LABOR TIME AND/OR PARTS)**

Additional repairs identified as necessary to complete the FSA should be managed as follows:

- For related damage and access time requirements, refer to the Warranty and Policy Manual / Section 6 – Ford & Lincoln Program Policies / General Information & Special Circumstances for FSA's / Related Damage.
- For vehicles within new vehicle bumper-to-bumper warranty coverage, no SSSC approval is required, although related damage must be on a separate repair line with the "Related Damage" radio button checked.
  - Ford vehicles – 3 years or 36,000 miles
- For vehicles outside new vehicle bumper-to-bumper warranty coverage, submit an Approval Request to the SSSC Web Contact Site prior to completing the repair.

**NEW VEHICLE DEMONSTRATION / DELIVERY HOLD - Safety Recall 19S17- Supplement #3**

Certain 2011-2017 Model Year Explorer Vehicles  
Rear Suspension Toe Link Replacement

**CLAIMS PREPARATION AND SUBMISSION**

- **Claim Entry:** Enter claims using Dealer Management System (DMS) or One Warranty Solution (OWS) online.
  - When entering claims, select claim type 31: Field Service Action. The FSA number (19S17) is the sub code.
  - For additional claims preparation and submission information, refer to the Recall and Customer Satisfaction Program (CSP) Repairs in the OWS User Guide.
- **Related Damage/Additional labor and/or parts:** Must be claimed as Related Damage on a separate repair line from the FSA with same claim type and sub code as described in Claim Entry above.

**IMPORTANT:** Click the Related Damage Indicator radio button.
- **Refunds:** Submit refunds on a separate repair line.
  - Program Code: 19S17                      - Misc. Expense: ADMIN
  - Misc. Expense: REFUND                      - Misc. Expense: 0.2 Hrs.
  - Multiple refunds should be submitted on one repair line and the invoice details for each repair should be detailed in the comments section of the claim.

**NOTE:** *The rear toe link kit part numbers have been updated. All repairs completed on or after February 18, 2022 must use the updated parts.*

**NOTE:** *If affected the Ford system will automatically close 19S17 upon claim payment of 16S18, 17S11, 18S43, 20S62, or 21S32.*

**NEW VEHICLE DEMONSTRATION / DELIVERY HOLD - Safety Recall 19S17 - Supplement #3**

Certain 2011-2017 Model Year Explorer Vehicles  
Rear Suspension Toe Link Replacement

**NEW! LABOR ALLOWANCES**

Description	Labor Operation	Labor Time
Replace both rear suspension toe links	19S17J	0.4 Hours
Check alignment and, if necessary, adjust rear toe – <b>All Vehicles</b>	19S17C	0.6 Hours

**NEW! PARTS REQUIREMENTS / ORDERING INFORMATION**

**NOTE:** The rear toe link kit part numbers have been updated. All repairs completed on or after February 18, 2022 must use the updated parts.

Part Number	Description	Engine	AWD/ FWD	Claim Quantity	Order Quantity
DB5Z-5A972-T	Rear Toe Link Kit – See affected Engine and AWD/FWD detail	3.5L TiVCT	AWD	1	1
		3.5L GTDI			
		3.7L DOHC	FWD		
		3.7L DOHC			
DB5Z-5A972-U	Rear Toe Link Kit – See affected Engine and AWD/FWD detail	2.3L GTDI	AWD	1	1
		2.3L GTDI	FWD		
		2.0L GTDI			
		3.5L TiVCT			

Order your parts through normal order processing channels. To guarantee the shortest delivery time, an emergency order for parts must be placed.

**DEALER PRICE**

For latest prices, refer to DOES II.

**PARTS RETENTION AND RETURN**

Follow the provisions of the Warranty and Policy Manual, Section 1 - WARRANTY PARTS RETENTION AND RETURN POLICIES. If a replaced part receives a scrap disposition, the part must be scrapped in accordance with all applicable local, state and federal environmental protection and hazardous material regulations. Federal law prohibits selling motor vehicle parts or components that are under safety, compliance, or emissions recall.

**NEW VEHICLE DEMONSTRATION / DELIVERY HOLD - Safety Recall 19S17 - *Supplement #3***

Certain 2011-2017 Model Year Explorer Vehicles  
Rear Suspension Toe Link Replacement

**EXCESS STOCK RETURN**

Excess stock returned for credit must have been purchased from Ford Customer Service Division in accordance with Policy Procedure Bulletin 4000.

**New! REPLACED FSA PARTS INSPECTION AND SIGN OFF**

*Effective March 1<sup>st</sup> 2021 all parts replaced as part of an FSA repair with a repair order open date of March 1<sup>st</sup> 2021 or later must be inspected and signed off on the repair order by a member of your dealers fixed operations management team or an employee the task has been delegated to. If the task is to be delegated to a non-management employee, the employee needs to be someone other than the technician who completed the repair and needs to understand the importance of completing this task consistently and accurately.*

- All parts replaced as part of an FSA repair should be returned to the parts department following the Warranty Parts Retention and Return Policies.*
- Inspect the replaced parts to verify the FSA repair was completed.*
- If the FSA repair is found to be complete, the designated employee signs the repair order line or parts return stamp area (electronic or hand signed) for the FSA repair indicating the parts were inspected and validated to have been replaced.*
- After the parts have been inspected, they should be handled based on the guidance in the parts status report in the Online Warranty System (Hold, Return, CORE, Scrap, etc.).*
- This process is subject to review during warranty audits for FSA repairs with a repair order open date of March 1<sup>st</sup> 2021 or later. Any eligible FSA claims requiring parts replacement, found not to have been inspected and signed off during a warranty audit will be subject to chargeback and consideration for enrollment into the Dealer Incomplete Recall Repair Process.*

**Note:** *Other approvals (electronic or handwritten) for add-on repair lines, dealer owned vehicle repairs, and repeat repairs do not qualify as FSA parts inspection approvals. The post repair FSA parts inspection process (electronic or handwritten) is independent from other warranty approval requirements. The approval by the designated employee implies that the FSA parts were found to be replaced and must be able to be clearly identified on the Repair Order. If multiple FSA's require approval on a single Repair Order, each applicable occurrence will require individual post repair approval by the designated employee.*

## CERTAIN 2011-2017 MODEL YEAR EXPLORER VEHICLES — REAR SUSPENSION TOE LINK REPLACEMENT

### **NEW!** SERVICE PROCEDURE

**⚠ WARNING:** Suspension fasteners are critical parts that affect performance of vital components and systems. Tighten fasteners as specified. Measure the distance from the center of the wheel hub to the lip of the fender with the vehicle in a level, static ground position (ride height) before disassembly. When securing the *new* toe link, it must be secured at the previously measured ride height.

**⚠ WARNING:** Tighten the suspension bushing fasteners with the suspension supported at ride height or with the weight of the vehicle resting on the wheels and tires, otherwise toe link and bushing damage may occur.

**NOTE:** *This recall is to be performed on both the right rear and the left rear suspension.*

**NOTE:** *It is recommended to perform this entire procedure on an alignment rack.*

- 1. Position the vehicle on an alignment rack. Please follow the WSM procedures in Section 100-02.*
- 2. Raise the rear of the vehicle by lifting the lower coil spring leaf.*
- 3. Remove both rear tires. Please follow the WSM procedures in Section 204-04A.*





4. Remove and discard both rear toe links. See Figure 1.

1. Remove and discard the toe link-to-wheel knuckle bolts and nuts.

2. Remove and discard the toe link-to-subframe bolt and remove the toe links.

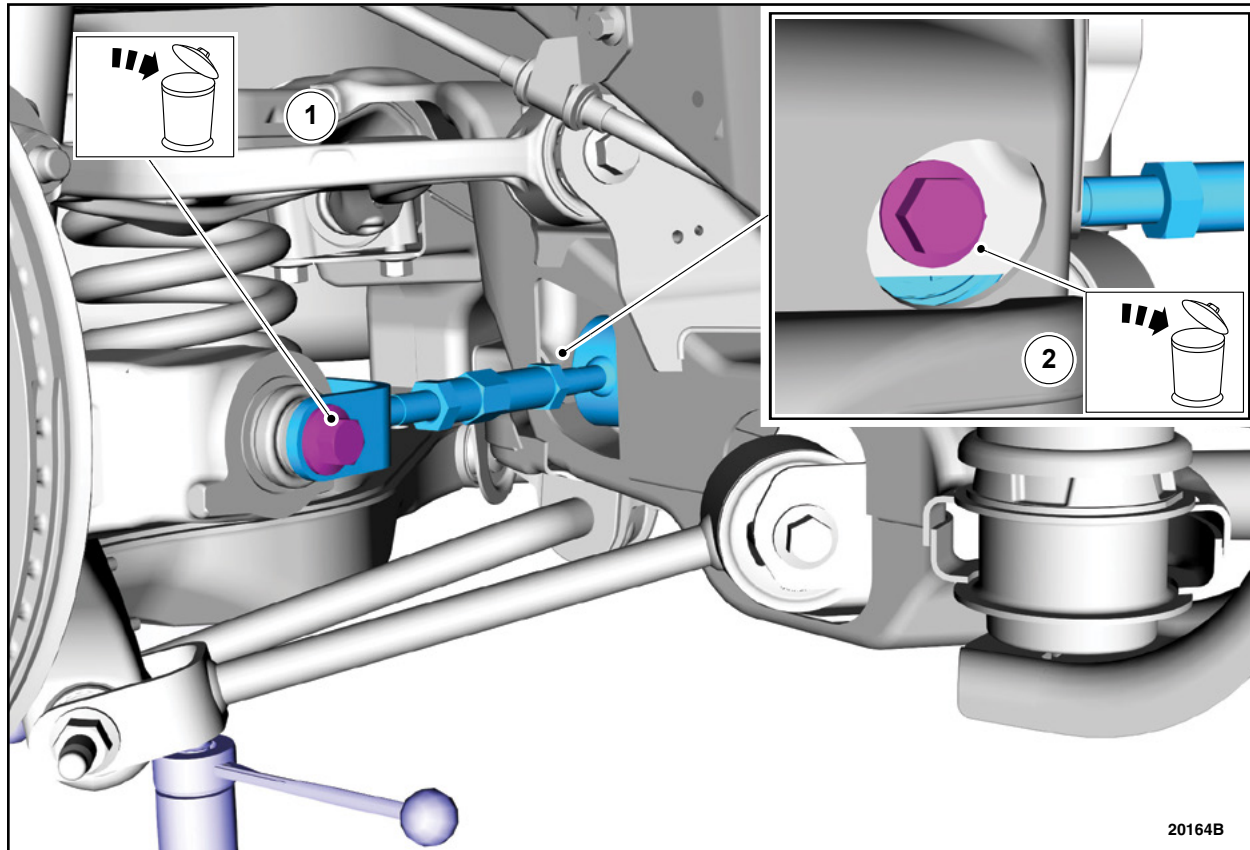

**FIGURE 1**

**NOTE:** Do not torque the fasteners at this time.

5. Install the new toe links by reversing the removal procedure. See Figure 1.

- Only hand tighten the inboard fastener and snug the outboard retainer at this time.

6. Install both rear tires. Please follow the WSM procedures in Section 204-04A.

7. Lower the vehicle onto the alignment rack with the rear adjustment rack slip plates loose.

8. Tighten the inboard rear toe link bolts on both sides.

- Torque: 111 lb.ft (150 Nm)



9. Set the tire pressure and perform an alignment and tighten the outboard bolt and nut on both sides.  
This completes the recall.

- Torque: 111 lb.ft (150 Nm)

**NOTE:** the frame side of the new toe link has a slot that is used for the alignment process. See Figure 2.

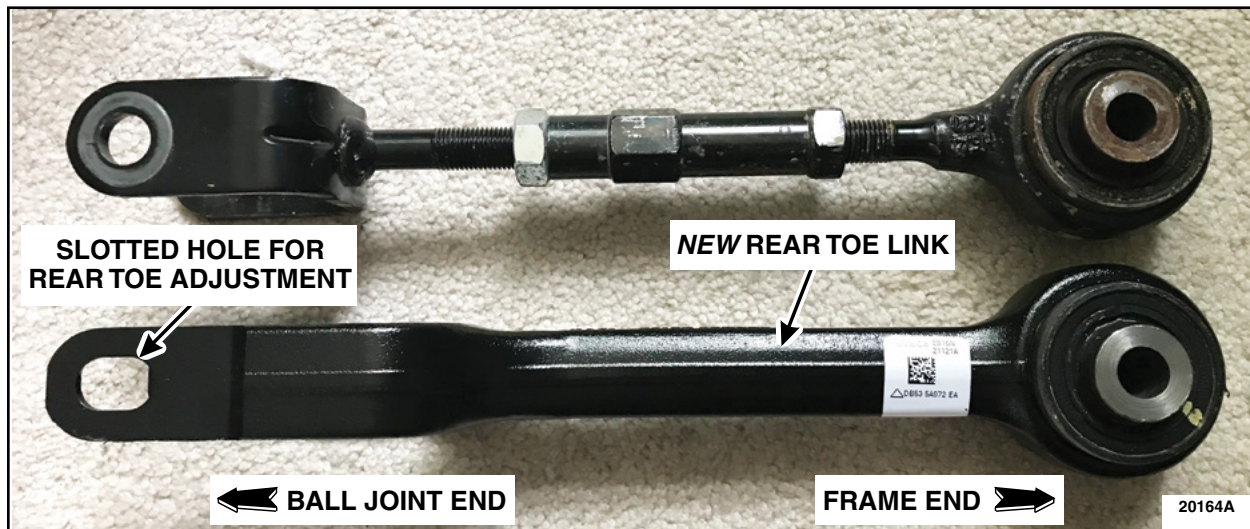

**FIGURE 2**

**IMPORTANT NOTE:** Federal law prohibits selling motor vehicle parts or components that are under safety, compliance, or emissions recall. Unless a part is requested to be returned to Ford, all parts replaced under this FSA must be scrapped in accordance with all applicable local, state and federal environmental protection and hazardous material regulations. Refer to the Parts Retention, Return, & Scrapping section of the FSA dealer bulletin for further information.



**NEW VEHICLE DEMONSTRATION / DELIVERY HOLD - Safety Recall 19S17 - *Supplement #3***

Certain 2011-2017 Model Year Explorer Vehicles  
Rear Suspension Toe Link Replacement

**Recommended Repair:**

If 2011-2019 Ford Explorers or PIU vehicles require service of the rear wheel knuckle and/or rear wheel knuckle bushings, the recommended repair is to replace the affected rear wheel knuckle (5B758/9) as an assembly only. Refer to WSM, Section 204-02, and the Ford Service Parts Catalog as needed.

**Issue:**

Ford has received reports of toe link failures on customer vehicles after the installation of non-OEM cross-axial ball joints (aka bushings) in the rear wheel knuckle. Installation of aftermarket bushings rather than replacement of the rear wheel knuckle assembly is not recommended, as this may limit the movement of the joint and cause stress on the toe link. In the reports that Ford received, the toe links failed shortly after installation of an aftermarket bushing installed by the dealership.

Dealerships may have serviced rear wheel knuckles, including use of aftermarket bushings, as part of preventive maintenance. These inspections and maintenance services sometimes took place as a separate customer paid repair when the vehicle was being serviced for the following FSAs: 19S17, 17G01, 16S18. Because these repairs would occur as a customer paid repair directly to the dealership and not submitted to Ford for reimbursement, Ford does not have a record of how many of these repairs may have occurred.

**Dealership Actions:**

If your dealership performed repairs on the rear suspension of 2011-2019 Ford Explorers or PIU vehicles and installed aftermarket bushing(s) in the rear wheel knuckle instead of replacing the complete rear wheel knuckle assembly (at any time), you should identify all of the vehicles repaired with the aftermarket bushing(s), contact the customer, and replace the rear wheel knuckle as an assembly. Failure to do this may result in a toe link fracture. A fractured rear toe link will cause a sudden change in vehicle handling and increase the risk of a crash.

**NEW VEHICLE DEMONSTRATION / DELIVERY HOLD - Safety Recall 19S17 - Supplement #3**  
Certain 2011-2017 Model Year Explorer Vehicles  
Rear Suspension Toe Link Replacement

KNUCKLE BALL JOINT/BUSHING LOCATIONS

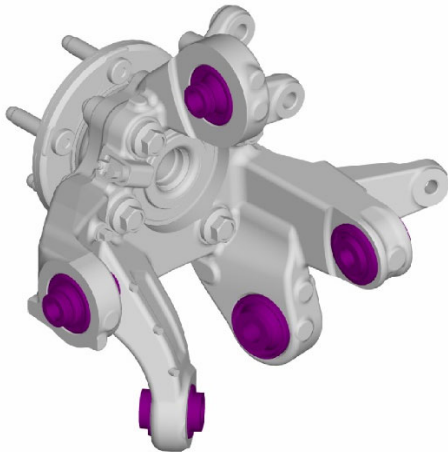

RIGHT REAR TOW LINK BALL JOINT

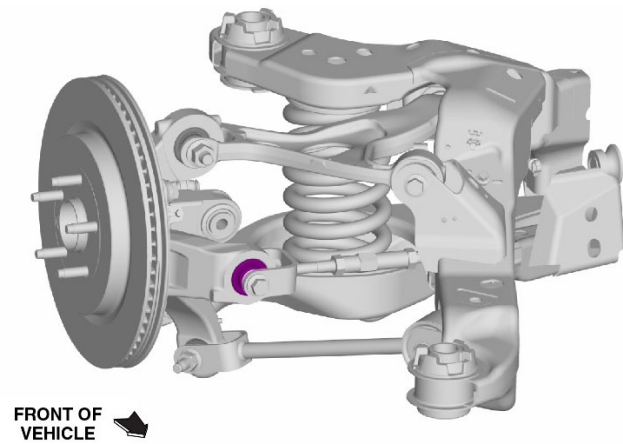

**Ford Motor Company**  
**Recall Reimbursement Plan for 19S17**

*Ford and Lincoln dealers are in the best position to quickly and efficiently process reimbursement requests. However, federal legislation requires all motor vehicle manufacturers to establish processes through which customers may seek recall reimbursement directly from the manufacturer or from the dealers.*

*Regarding the specific reimbursement plan for Recall # 19S17, owners who have paid for service to remedy the defect or noncompliance must have had that service performed prior to July 12, 2019. After this date, if repairs related to this recall are performed by a non-Ford repair facility in an emergency situation, customers must submit any refund requests through their dealership. As required by this federal regulation, Ford Motor Company submitted the details of its latest General Recall Reimbursement Plan in a letter to the National Highway Traffic Safety Administration (NHTSA) in February 2019. The following is the text of that letter and the Plan:*

**General Recall Reimbursement Plan**  
(As submitted to the NHTSA)

Pursuant to the requirements set forth in 49 CFR Part 573 and Part 577 of the Code of Federal Regulations, Ford Motor Company (Ford) is submitting required information pertaining to our general reimbursement plan for the cost of remedies paid for by vehicle owners before they are notified of a related safety recall.

Set forth below is Ford's general plan to reimburse owners and purchasers for costs incurred for remedies in advance of notification of potential safety-related defects or noncompliances pursuant to Part 573.6 (c)(8)(i). This plan has not changed since our February 20, 2019 submission.

**Reimbursement Notification**

Ford's notice to a vehicle owner in accordance with 49 CFR Part 577 will indicate that Ford is offering a refund if the owner paid to have service to remedy the defect or noncompliance prior to a specified ending date. In accordance with Part 573.13 (c)(2), this ending date will be defined as a minimum of ten calendar days after the date on which Ford mailed the last of its Part 577 notifications to owners, and will be indicated in the specific reimbursement plan available to owners for an individual recall. This notice will direct owners to seek eligible reimbursement through authorized dealers or, at their option, directly through Ford at the following address:

Ford Motor Company  
P.O. Box 6251  
Dearborn, MI 48121-6251

Ford notes that this rule allows for the identification of a beginning date for reimbursement eligibility. Under the rule, an owner who paid to remedy the defect or noncompliance prior to the identified beginning date would not be eligible for reimbursement. Ford generally has not established such a beginning date for reimbursement eligibility and does not presently anticipate changing this general policy. However, in any case where Ford determines a beginning date is appropriate, Ford will indicate that date in the owner notice. As permitted by 577.11(e), Ford may not include a reimbursement notification when all vehicles are well within the warranty period, subject to approval by the agency.

## **Costs to be Reimbursed**

For vehicles, reimbursement will not be less than the lesser of:

- The amount paid by the owner for the remedy that specifically addressed and was reasonably necessary to correct the defect or noncompliance that is the subject of the recall, or
- The cost of parts for the remedy (to be no more than the manufacturer's list retail price for authorized part(s), plus associated labor at local labor rates, miscellaneous fees (such as disposal of waste) and taxes.

For replacement equipment, reimbursement will be the amount paid by the owner for the replacement item (limited by the amount of the retail list price of the defective or noncompliant item that was replaced, plus taxes, where the brand or model purchased by the owner was different than the brand or model that was the subject of the recall). If the item of motor vehicle equipment was repaired, the reimbursement provisions identified above for vehicles will apply.

Ford notes that costs incurred by the owner within the period during which Ford's original or extended warranty would have provided for a free repair of the problem will not be eligible for reimbursement, as provided by Part 573.13 (d)(1).

### Entities Authorized to Provide Reimbursement

Ford will continue to use authorized dealers to reimburse owners under the specific reimbursement plans for a particular recall, and will encourage owners to pursue requests for reimbursement directly through dealers to expedite reimbursement. Ford will also provide a mailing address to which customers can, at their option, send requests for reimbursement directly to Ford, as previously noted. Requests for reimbursement sent directly to Ford may take up to 60 days to process. Whether the owner chooses to pursue reimbursement requests through a dealer or directly through Ford, the owner will be directed to submit the required documentation, upon which reimbursement eligibility will be determined.

### **Required Documentation**

The reimbursement determination will depend upon the information provided by the customer. Consistent with Part 573.13 (d)(4) the following information must be submitted:

- Claimant name and address
- Vehicle make, model, and model year
- Vehicle identification number (VIN) and, for replacement equipment, a description of such equipment or, for tires, the model, size and TIN (DOT code)
- Identification of the recall number (either the Ford recall number or the NHTSA recall number)
- Identification of the owner of the recalled vehicle at the time that the pre-notification remedy was obtained
- An original receipt for the pre-notification remedy that includes a breakdown of the amount for parts, labor, other costs and taxes, including costs for the replacement item. Where the receipt covers work other than to address the recall or noncompliance, Ford may require the claimant to separately identify costs that are eligible for reimbursement.
- If the remedy was obtained during the warranty period, documentation indicating that the warranty was not honored or the warranty repair did not correct the problem related to the recall.

Failure to submit all of the above information may result in denial of the reimbursement request.

**Additional Information**

The Part 577 required owner notice will provide a toll-free telephone number through which specific information about the reimbursement plan can be requested from Ford. This general reimbursement plan will be incorporated into notifications pursuant to Part 573.6 by reference. Information specific to an individual recall also may be incorporated into the Part 573.6 notification.