



## MAZDA DEALER EMAIL

---

June 7, 2019

**Attention: Mazda General, Parts and Service Managers**

**Subject: 2019 Mazda3 Wheel Lug Nuts Loosening Concern - Safety Recall 3519F**

Mazda Motor Corporation has decided to conduct a Safety Recall Campaign to address a concern with certain 2019 Mazda3 vehicles, produced from September 25, 2018 through May 3, 2019, affecting 24,865 US vehicles.

**Action Required:**

Currently there are 16,555 unsold affected vehicles that are in dealer inventory or arriving to your dealership. **These vehicles must not be delivered to customers until the recall repair has been completed. As a reminder, all vehicles will show as "Not Launched" status in eMDCS; please repair when any affected vehicle shows up at your dealership.**

Affected Vehicles:

Model	Subject VIN range	Subject production date range
2019 Mazda3 (built at MC)	JM1 BP**** K1 100042 - 136438	From September 25, 2018 through April 19, 2019
2019 Mazda3 (built at MMVO)	3MZ BP**** KM 100048 - 112386	From January 15, 2019 through May 3, 2019

Concern Outline:

On certain subject vehicles, the wheel lug nuts may loosen and fall off during normal driving. Continuous use in such condition may lead to a wheel falling off the vehicle, and there could be a loss of vehicle control.

No field cases of wheel separation have been reported. Rattling noise will occur prior to a wheel falling off the vehicle.

Causal factor: A manufacturing process error may create a partial gap between the hub bolt head and hub flange during assembly. This gap may cause a loss of torque and eventual loosening of the lug nut if they were tightened prior to

proper seating of the hub bolt, even though they were tightened to the correct specification at the plant.

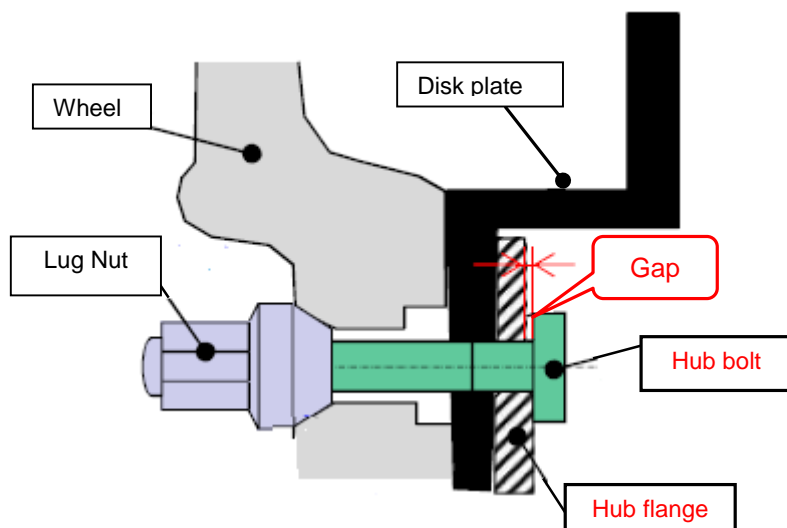

Outline of repair:

Retighten the front and rear wheel lug nuts from 137Nm (101 ft. lb.) to 147Nm (108 ft. lb.).

Special Note - This recall repair must be done even though a pre-delivery inspection ("PDI") may have been performed.

Owner Notification:

Mazda will notify owners of affected vehicles by first class mail as soon as possible by late June, 2019 and no later than August 6, 2019. Owners will be asked to bring their vehicle to the nearest Mazda dealership for repairs.

Important Safety Notice: The National Traffic and Motor Vehicle Safety Act prohibits the delivery of any subject vehicle without performing the necessary repair for defects or failures. Failure to perform applicable recalls before delivery can result in extensive dealer fines and penalties from the Federal Government. Therefore, you must complete this recall for all affected vehicles in your inventory prior to delivery.

To help you effectively perform this recall, Mazda has developed the following resources:

1. Affected unsold VIN list will post on MGSS by June 7, 2019. Warranty information and Repair procedures will post on MGSS (Mazda Global Service Support) websites via MXConnect as soon as available, approximately June 11, 2019.
2. For warranty questions, contact the Warranty Hotline at (877) 727-6626, Option 3.
3. Vehicles will display in eMDCS as "Not Launched" on June 07, 2019.  
\*\*NOTE\*\* Repairs are encouraged to be completed while in "Not Launched" status.

Please make certain the appropriate personnel in your dealership are aware of these resources and are familiar with the details of this recall before responding to customer inquiries.

We apologize for any inconvenience this recall may cause you and your customers. Your understanding and support in carrying out this campaign is

greatly appreciated.

**Protect What is Important to You**

Mazda North American Operations

Sincerely,

Hideo Takashima  
Director, Technical Services Division  
Mazda North American Operations

---

MAZDA NORTH AMERICAN OPERATIONS