

Product Safety Recall

17477 Front Passenger Air Bag Inflator



Reference Number: N161644421

Release Date: March 2018

Revision: 01

Revision Description: This bulletin has been revised to correct the Parts Section. The quantity indicated for Part Number 19184760 should be two not one. Please discard all copies of bulletin 17477.

Attention: It is a violation of Federal law for a dealer to deliver a new motor vehicle or any new or used item of motor vehicle equipment (including a tire) covered by this notification under a sale or lease until the defect or noncompliance is remedied.

Involved are all 2010 model year Pontiac Vibe vehicles not previously recalled for this condition.

All involved vehicles that are in dealer inventory must be held and not delivered to customers, dealer traded, or used for demonstration purposes until the repair contained in this bulletin has been performed on the vehicle.

Make	Model	Model Year		RPO	Description
		From	To		
Pontiac	Vibe	2010	2010		

Involved vehicles are marked "open" on the Investigate Vehicle History screen in GM Global Warranty Management system. This site should always be checked to confirm vehicle involvement prior to beginning any required inspections and/or repairs.

Condition	The Pontiac Vibe was manufactured by New United Motor Manufacturing, Inc. (NUMMI), a joint venture between Toyota and General Motors. Toyota has decided that a defect, which relates to motor vehicle safety, exists in all 2010 model year Pontiac Vibe vehicles not previously recalled for this condition. As a result, GM is conducting a safety recall.
	The subject vehicles are equipped with front passenger air bag inflators which may have been manufactured in such a way as to have a potential for the intrusion of moisture over time. This could create excessive internal pressure when the air bag is deployed and cause the inflator to explode. In the event of an inflator explosion, sharp metal fragments could pass through the airbag cushion material, striking the vehicle occupants and result in serious injury or death.
Correction	Dealers are to replace the front passenger air bag inflator.

Parts

Parts required to complete this recall are to be obtained from General Motors Customer Care and Aftersales (GMCCA). Dealers should refer to their "involved vehicles listing" before ordering parts. **Parts are currently in limited supply and dealers should order as a Customer Special Order (CSO) only and the complete 17-character Vehicle Identification Number (VIN) must be included in the note field.** Daily Replenishment Orders (DRO's) may be cancelled. **Please do not place orders as SPAC;** doing so will delay shipment of the part and will not provide visibility in the order tracking system. All orders will be reviewed prior to being filled.

Due to flight restrictions for hazardous goods shipments, dealer orders may arrive via FedEx or with the normal Parts Distribution Center (PDC) delivery. Parts will not be shipped overnight and dealers should plan accordingly for the possibility of extended transit time.

Important: Parts may be removed from Retail Inventory Management (RIM) management. Dealers should review the affected parts to confirm RIM managed status. **Parts may have quantity limiters in effect.**

Quantity	Part Name	Part No.
1	INFLATOR ASM, I/P MDL AIR BAG	84331282
2	RETAINER (Merch Pack of 2)	19184760

Important: Do not discard or destroy the box containing the new front passenger air bag inflator, it will be needed to return the used air bag inflator. The box contains special shipping instructions for the packaging and return of the used air bag inflator.

For USA Dealers Only: Follow the special shipping instructions that are in the box containing the new air bag inflator.

For Canada Dealers Only: Disregard the special shipping instructions that are in the box containing the new air bag inflator. Please use the revised Canada only packaging and return shipping instructions at the end of the bulletin.

All instructions must be followed without exception. **DO NOT DEPLOY ANY INFLATOR PRIOR TO SHIPMENT.**

Product Safety Recall

17477 Front Passenger Air Bag Inflator



Warranty Information

Labor Operation	Description	Labor Time	Trans. Type	Net Item
9103134	Replace Front Passenger Air Bag Inflator	1.4	ZFAT	*

* Submit a \$20.00 administrative allowance for return of the used front passenger air bag inflator assembly (document preparation and packaging). Add this amount in the Net / Admin Allowance field when submitting the repair transaction.

Service Procedure

Note: This field action bulletin provides service repair and labor time information for replacing the passenger side air bag inflator module. Other repairs, if required, are to be billed under warranty, goodwill assistance or customer pay.

Danger: Wait at least 90 seconds after disconnecting the cable from the negative battery terminal to prevent air bag and seat belt pretensioner deployment.

Caution: Avoid scratching or damaging the dashboard assembly. Place protective tape on the dashboard if needed.

1. Remove the instrument panel passenger air bag assembly. Refer to *Air Bag Instrument Panel Module Replacement* in SI.
2. Place the air bag module on a clean work bench.

Safety Precautions

Warning: Failure to follow these procedures correctly could cause the SRS to unexpectedly deploy during servicing or the SRS may fail to operate correctly when required after reassembly. Confirm all work is performed as described in these instructions.

Warning: If an air bag system is not handled using proper procedures and methods, it may be activated accidentally during work resulting in a life-threatening serious accident. If the service procedure is NOT performed correctly, the system may fail to activate when needed. Be sure to perform the proper work safely and according to the instructions in this service procedure.

1. **Eliminate Static Electricity.** Before start of work, touch a metallic portion of the vehicle with a bare hand to discharge static electricity charged on your body.
2. **DO NOT Measure Resistance.** DO NOT measure resistance of air bag components. Measuring current of a circuit tester may cause accidental activation.
3. **Handle The Air Bag Properly.**
 - 3.1. **If an inflator is dropped, replace it with a NEW inflator.**
 - 3.2. **Keep the deploying side facing upward except for when the inflator is replaced. DO NOT put anything on the airbag.**
 - 3.3. **Be sure to place parts properly. Otherwise a life-threatening serious accident may occur in case of accidental activation.**
4. **DO NOT Allow Foreign Objects Near Air bag.**
 - a. Be sure to collect and account for all removed nuts/bolts to prevent them from landing in the air bag assembly.
 - b. Any foreign objects in the air bag assembly may cause damage or injury if the air bag is activated.
5. **Wear Protective Equipment.** Always wear appropriate protective equipment when working on the air bag.

Front Passenger Air Bag Inflator Module Replacement

- **IMPORTANT NOTICE WHEN CONNECTING INSTRUMENT PANEL WIRE CONNECTOR TO AIRBAG INFLATOR-**Once connected, the instrument panel wire connector cannot be disconnected from the airbag inflator. If the instrument panel wire connector is incorrectly connected to the inflator, replace the instrument panel wire and inflator with **NEW** ones.
- **BEFORE** starting work and periodically while working on the air bag module, touch a metallic part of the work bench to discharge static electricity in the body.

Product Safety Recall

17477 Front Passenger Air Bag Inflator



- Wait at least 90 seconds after disconnecting the cable from the negative battery terminal to prevent airbag and seat belt pretensioner deployment.
- Follow all precautions as outlined on TIS before servicing the SRS system.

Warning: Confirm the stopper plate to inflator fitment is correct. *DO NOT* pinch the harness between the inflator and the stopper plate.

Warning: When working with the airbag module, avoid standing directly in front of the parts

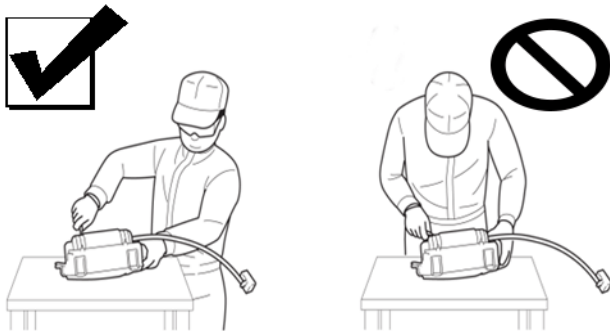

4751076

Warning: Before starting work and periodically while working on the vehicle, touch a metallic part of the vehicle to discharge static electricity in the body.

Note: Put a mark on each of the 5 loosened self-locking nuts to prevent accidental reuse.

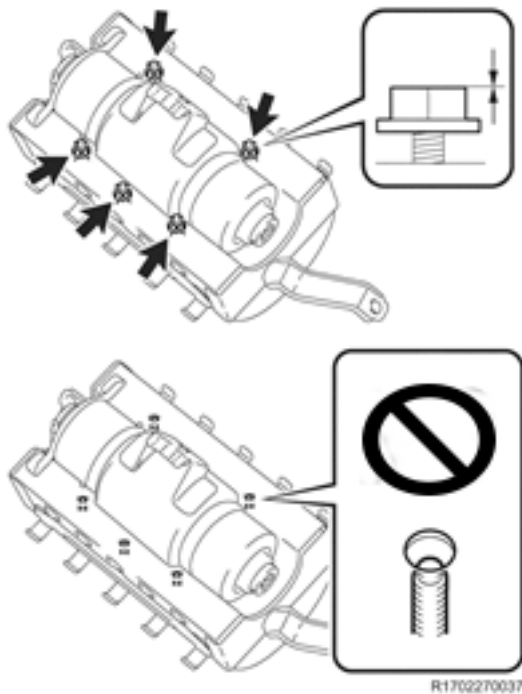

4751077

1. Loosen the 5 self-locking nuts until each face becomes flush with the edge of the stud bolt.

Product Safety Recall

17477 Front Passenger Air Bag Inflator



Important: DO NOT use an air driven tool. The stud bolt may fall inside if it is pushed down strongly while the 5 nuts are removed.

2. Remove the 2 self-locking nuts and plate. Store the removed self-locking nuts and plate in a parts box or the like.
3. Remove the inflator. Put an "X" on the inflator to prevent accidental reuse and store in a replacement box or the like.

Important: DO NOT insert the inflator fully.

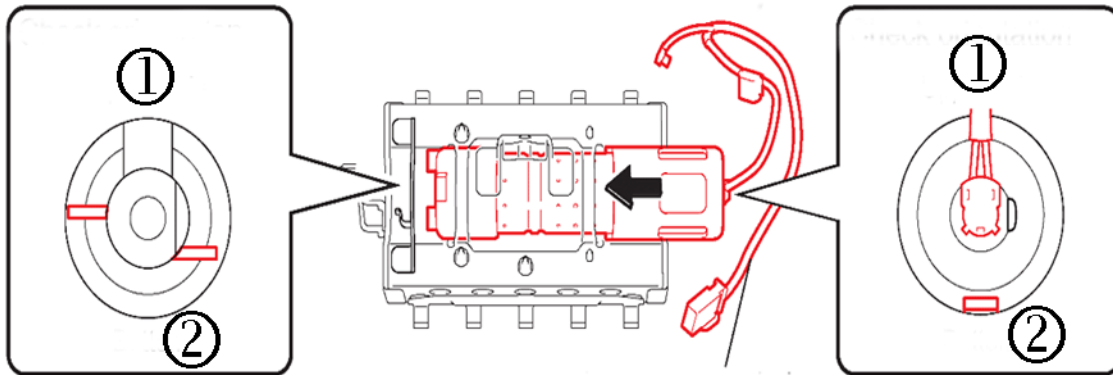

4751078

4. Insert a NEW inflator to the center of the airbag case with the correct orientation as shown (1) Upper side (2) Bottom.
 - If the passenger airbag inflator is upside down, it will not be able to be fully inserted.
 - Make sure that the passenger airbag inflator is oriented correctly as shown, not upside down.

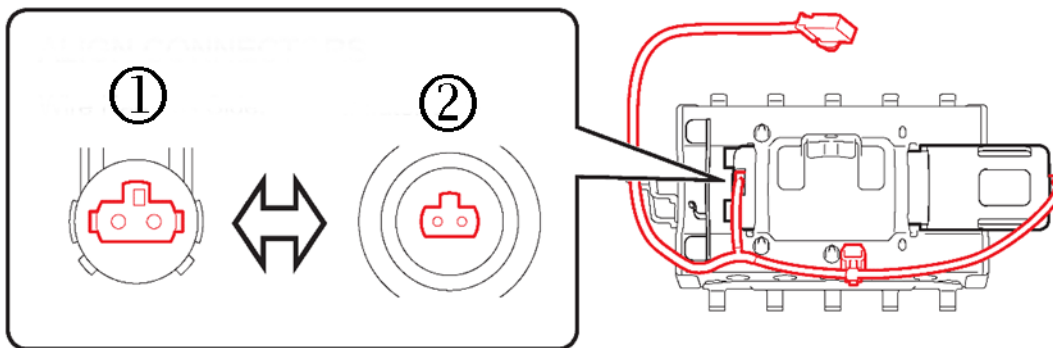

4751079

5. Connect the connector and push in each airbag connector lock as shown (1). Wire harness side (2) Inflator side.

Important: Make sure that the inflator is oriented correctly as shown in the illustration, not upside down. If the passenger airbag inflator is upside down, it will not be able to be fully inserted.

Product Safety Recall

17477 Front Passenger Air Bag Inflator

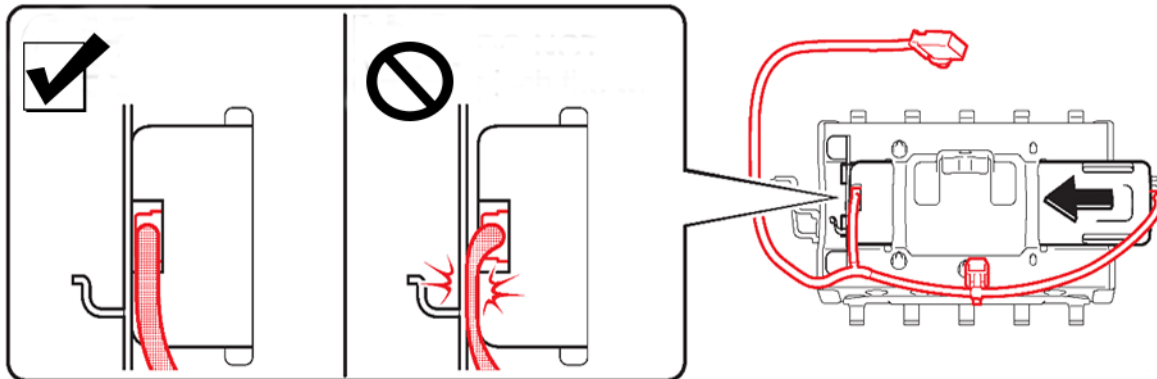

4751080

6. Insert the inflator fully with the correct orientation as shown. DO NOT pinch the wire.

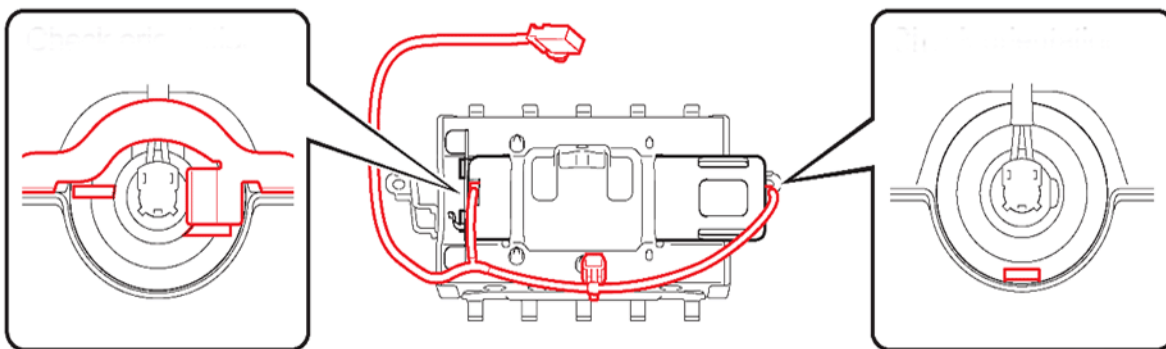

4751081

Product Safety Recall

17477 Front Passenger Air Bag Inflator

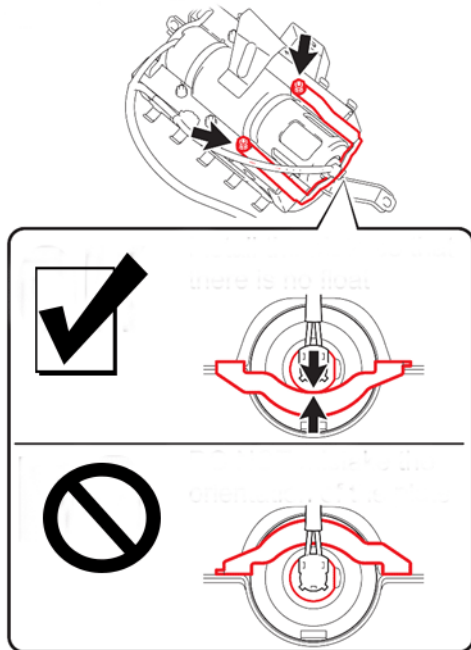

4751082

7. Temporarily install a **NEW** plate and airbag inflator with the 2 **NEW** self-locking nuts. Verify and check the orientation.
 - 7.1. **DO NOT** mistake the orientation of the plate.
 - 7.2. Make sure that there is no float.

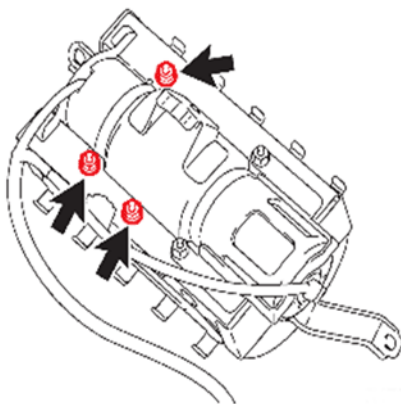

4751083

8. Remove the 3 remaining old self-locking nuts and install temporarily 3 **NEW** self-locking nuts by hand. Store the removed self-locking nuts in a replacement part box or the like.
9. Push the inflator and plate towards the position determining plate to eliminate any gap.

Important: If any gap exists, the aligned flats may move apart, resulting in failure in normal deployment of the airbag.

Product Safety Recall

17477 Front Passenger Air Bag Inflator

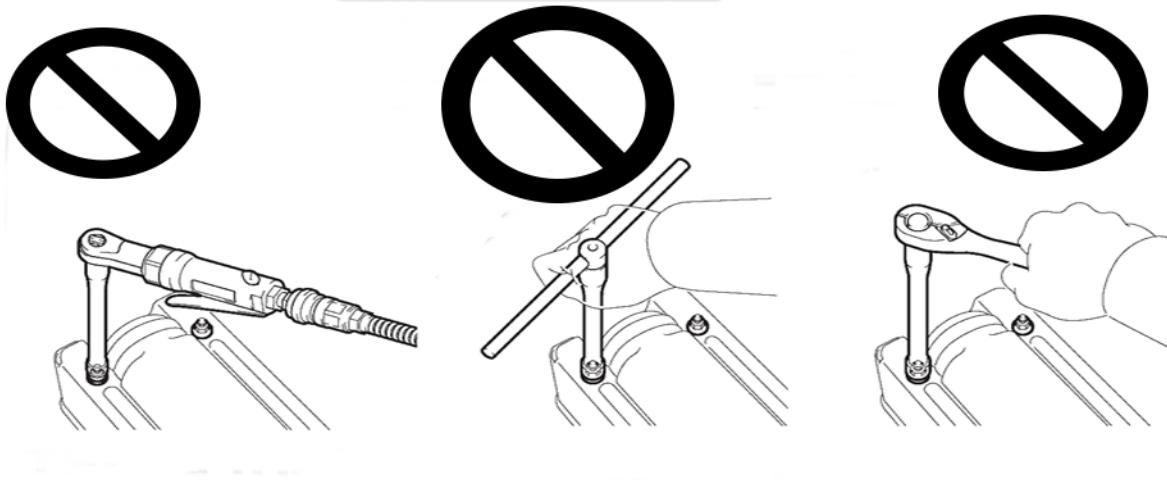

4751084

Important: The tightening torque is low (3.9 N·m). Use of an air ratchet wrench or tightening strongly with a T-handle wrench or a ratchet handle may cause deformation of the stud bolt.

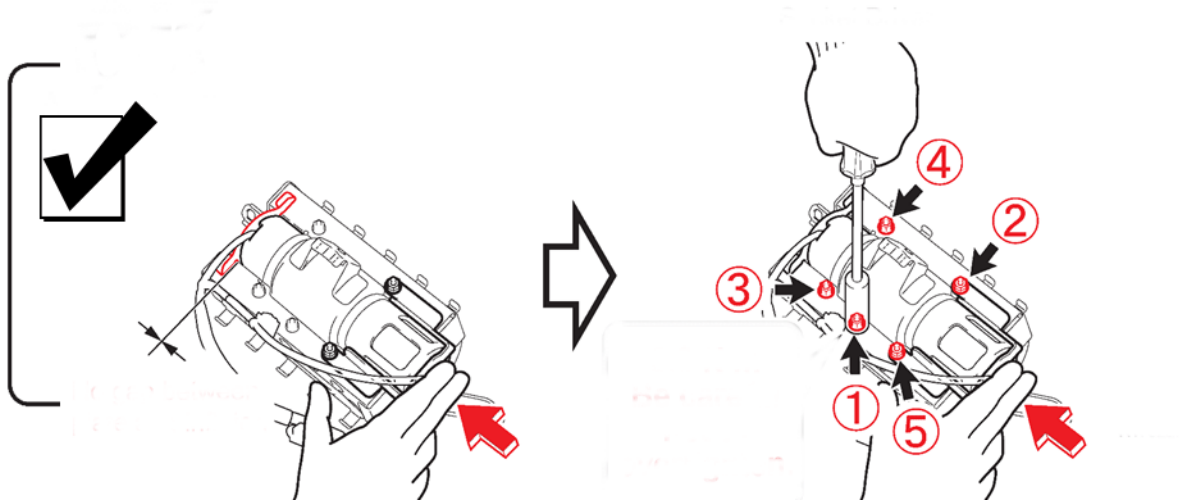

4751085

10. Tighten 5 nuts evenly in several increments in the order shown above using a socket driver while pushing the inflator and plate. (You will encounter some resistance during tightening because these nuts are self-locking nuts.). Torque: 3.9 N·m (40 kgf·cm, 35 in.·lbf).
11. Install the harness clip to the center stud after all 5 nuts have been torqued.

Product Safety Recall

17477 Front Passenger Air Bag Inflator

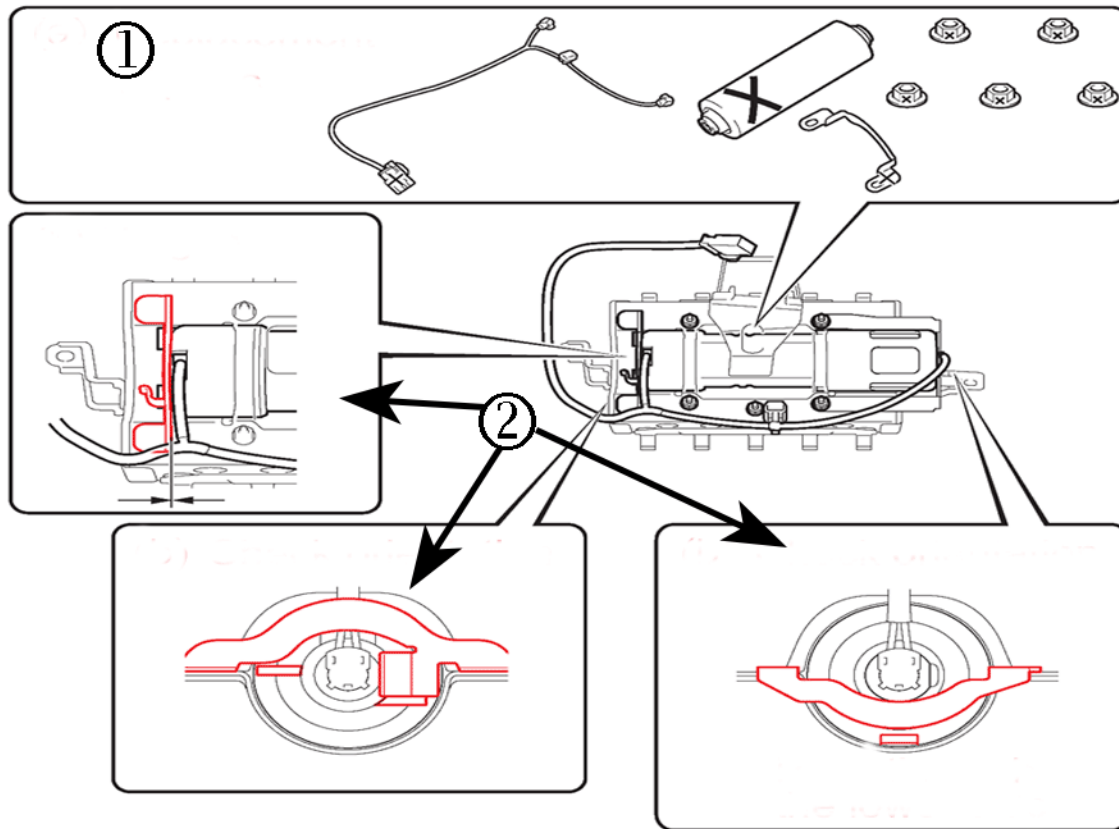

4751086

12. Check that the inflator and 5 self-locking nuts, instrument panel wire, plate (1) are replaced.
13. Check that positions of the inflator and the position determining plate are correct (2).
(The flats should be aligned and there should be no gap.)
14. Install the instrument panel (IP) compartment. Refer to Instrument Panel Compartment Replacement in SI.
15. Check that the airbag warning lamp lights when the power switch is turned on.
 - Check that the airbag warning lamp goes off approximately 6 seconds after turning on of the power switch.

Note: If the airbag warning lamp remains on, it is likely to be caused by connection failure of the airbag connector.

16. Connect the scan tool and determine if any diagnostic trouble codes (DTCs) have been set. Clear set DTCs, if required. Ensure no DTCs set after scan tool evaluation.

Dealer Responsibility – For U.S. & Export (U.S. States, Territories, and Possessions)

It is a violation of Federal law for a dealer to deliver a new motor vehicle or any new or used item of motor vehicle equipment (including a tire) covered by this notification under a sale or lease until the defect or noncompliance is remedied.

The U.S. National Traffic and Motor Vehicle Safety Act provides that each vehicle that is subject to a recall of this type must be adequately repaired within a reasonable time after the customer has tendered it for repair. A failure to repair within sixty days after tender of a vehicle is prima facie evidence of failure to repair within a reasonable time. If the condition is not adequately repaired within a reasonable time, the customer may be entitled to an identical or reasonably equivalent vehicle at no charge or to a refund of the purchase price less a reasonable allowance for depreciation. To avoid having to provide these burdensome remedies, every effort must be made to promptly schedule an appointment with each customer and to repair their vehicle as soon as possible. In the recall notification letters, customers are told how to contact the U.S. National Highway Traffic Safety Administration if the recall is not completed within a reasonable time.

Product Safety Recall

17477 Front Passenger Air Bag Inflator



Dealer Responsibility – All

All new, used, GM Certified Used, courtesy transportation vehicles, dealer shuttle vehicles, etc. in dealers' possession and subject to this recall must be held and inspected/repaired per the service procedure of this bulletin before customers take possession of these vehicles. Involved vehicles must be held and not delivered to customers, dealer-traded, released to auction, used for demonstration, or any other purpose.

All GM Certified Used vehicles currently in the dealers' inventory within the Certified Pre-Owned Inventory System (CPOIS) will be de-certified and must be held and remedied per the service procedure in this bulletin. Upon submitting an accepted/paid warranty transaction in the Global Warranty Management (GWM) system, the vehicle can be re-certified for sale within the CPOIS system, or once again be used in the CTP program.

Dealers are to service all vehicles subject to this recall at no charge to customers, regardless of mileage, age of vehicle, or ownership, from this time forward.

Customers who have recently purchased vehicles sold from your vehicle inventory, and for which there is no customer information indicated on the dealer listing, are to be contacted by the dealer. Arrangements are to be made to make the required correction according to the instructions contained in this bulletin. A copy of the customer letter is provided in this bulletin for your use in contacting customers. Recall follow-up cards should not be used for this purpose, since the customer may not as yet have received the notification letter.

In summary, whenever a vehicle subject to this recall enters your vehicle inventory, or is in your dealership for service in the future, you must take the steps necessary to be sure the recall correction has been made before selling or releasing the vehicle.

Dealer Reports

For dealers with involved vehicles, a listing with involved vehicles has been prepared and will be provided to U.S. and Canadian dealers through the GM GlobalConnect Recall Reports, or sent directly to export dealers. The listing may contain customer names and addresses obtained from Motor Vehicle Registration Records. The use of such motor vehicle registration data for any purpose other than follow-up necessary to complete this recall is a violation of law in several states/provinces/countries. Accordingly, you are urged to limit the use of this report to the follow-up necessary to complete this recall.

Customer Notification

U.S. & Canada - General Motors will notify customers of this recall on their vehicle (see copy of customer letter included with this bulletin).

Export - Letters will be sent to known owners of record located within areas covered by the U.S. National Traffic and Motor Vehicle Safety Act. For owners outside these areas, dealers should notify customers using the attached sample letter.

Product Safety Recall

17477 Front Passenger Air Bag Inflator



CANADA ONLY – Return Shipping Instructions for Used Air Bag Inflators

Shipping/Handling Instructions:

On top of the Box **CLEARLY WRITE (Large Print):**

“USED AIR BAG - RECALL # 17477”

Canadian Dealers: Air bag returns are to be processed through your normal return process. No return tag/credit will be issued for used air bags. Refer to recall bulletins for applicable returns required.

- Complete a PC0302C (302C) form and ensure that the TDG section is completed correctly.
- At time of return pickup, provide driver with the 302C form with the used air bag(s) properly manifested for shipment back to your Product Distribution Centre (PDC).

DRIVER WILL NOT PICK UP ANY AIR BAG(S) WITHOUT THIS FORM FILLED OUT AND SIGNED.

PDC contact and fax numbers for YOUR Servicing PDCs:

- Woodstock Service Dealers 519-536-7410 Fax: 519-536-7409
- Edmonton Service Dealers 780-451-7019 Fax: 866-350-6233
- Montreal Service Dealers 514-630-6162 Fax: 514-630-7362
- Vancouver Service Dealers 604-857-4347 Fax: 604-857-4402

GM bulletins are intended for use by professional technicians, NOT a "do-it-yourselfer". They are written to inform these technicians of conditions that may occur on some vehicles, or to provide information that could assist in the proper service of a vehicle. Properly trained technicians have the tools, equipment, safety instructions, and know-how to do a job properly and safely. If a condition is described, **DO NOT** assume that the bulletin applies to your vehicle, or that your vehicle will have that condition. See your dealer for information on whether your vehicle may benefit from the information.



**We Support
Voluntary Technician
Certification**



IMPORTANT SAFETY RECALL

March 2018

This notice applies to your vehicle, **VIN:** _____

Dear General Motors Customer:

This notice is sent to you in accordance with the National Traffic and Motor Vehicle Safety Act.

Toyota has decided that a defect, which relates to motor vehicle safety, exists in all 2010 model year Pontiac Vibe vehicles not previously recalled for this condition. The Pontiac Vibe was manufactured by New United Motor Manufacturing, Inc. (NUMMI), a joint venture between Toyota and General Motors. As a result, GM is conducting a safety recall. We apologize for this inconvenience. However, we are concerned about your safety and continued satisfaction with our products.

IMPORTANT

- Your vehicle is involved in GM safety recall 17477.
- Schedule an appointment with your GM dealer.
- This service will be performed for you at **no charge**.

Why is your vehicle being recalled?

The subject vehicles are equipped with front passenger air bag inflators which may have been manufactured in such a way as to have a potential for the intrusion of moisture over time. This could create excessive internal pressure when the air bag is deployed and cause the inflator to explode. In the event of an inflator explosion, sharp metal fragments could pass through the airbag cushion material, striking the vehicle occupants and result in serious injury or death.

What will we do?

Your GM dealer will replace your vehicle's front passenger air bag inflator. This service will be performed for you at **no charge**. The repair will take approximately one hour. Because of service scheduling requirements, it is likely that your dealer will need your vehicle for a longer period of time.

What should you do?

You should contact your GM dealer to arrange a service appointment as soon as possible.

Until the repair is performed, the front passenger seat should NOT be occupied.

Do you have questions?

If you have questions or concerns that your dealer is unable to resolve, please contact the appropriate Customer Assistance Center at the number listed below.

Division	Number	Text Telephones (TTY)
Pontiac	1-800-620-7668	1-800-833-7668
Puerto Rico – English	1-800-496-9992	
Puerto Rico – Español	1-800-496-9993	
Virgin Islands	1-800-496-9994	

If after contacting your dealer and the Customer Assistance Center, you are still not satisfied we have done our best to remedy this condition without charge and within a reasonable time, you may wish to write the Administrator, National Highway Traffic Safety Administration, 1200 New Jersey Avenue, SE, Washington, DC 20590, or call the toll-free Vehicle Safety Hotline at 1.888.327.4236 (TTY 1.800.424.9153), or go to <http://www.safercar.gov>. The National Highway Traffic Safety Administration Campaign ID Number for this recall is 18V025.

Federal regulation requires that any vehicle lessor receiving this recall notice must forward a copy of this notice to the lessee within ten days.

Maryann L. Combs
Vice President
Global Vehicle Safety

GM Recall Number: 17477