

NOTICE

Jost International has concluded a possibility exists that a production unit built containing a prototype component has been shipped. This single (1) unit has an incorrectly sized slider bracket that is easily detectable following the procedure on page two.

It is requested that trucks built between 6/9/18 to 6/29/18 that include one of the listed model numbers below be verified prior to use in the field due to quality and potential safety hazards. Please see page three of this notice for a list of VINS.

Jost estimates it will take (5) minutes per unit to perform the inspection with an additional (5) minutes admin time for claim submission. For prompt reimbursement, please provide the tractor VIN, build date, 5th wheel model serial number and the result if the unit passed or failed inspection on the warranty claim form located at: <https://www.jostinternational.com/warranty/>

Model Number

37USA-A-002
37USA-A-008
37USL-A-002
37USL-A-005
37USL-A-008

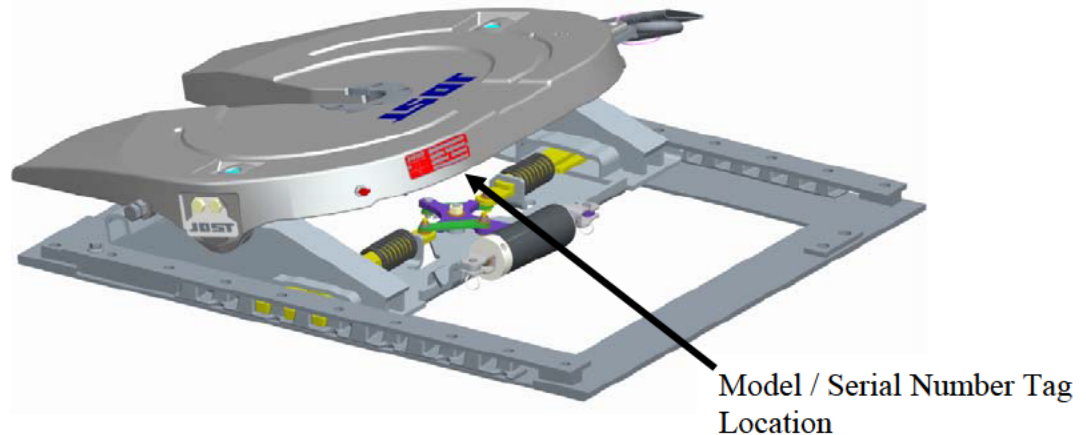

If inspection does result in finding the (1) unit in question, DO NOT use the tractor. Please call 800-253-5105 for immediate claim processing at which time a replacement bracket will be sent and credit of 1.5 hours for replacement will be given. Jost replacement procedure LT JSK37-13 will be provided.

Outboard Slider Side-to-Side Clearance Inspection

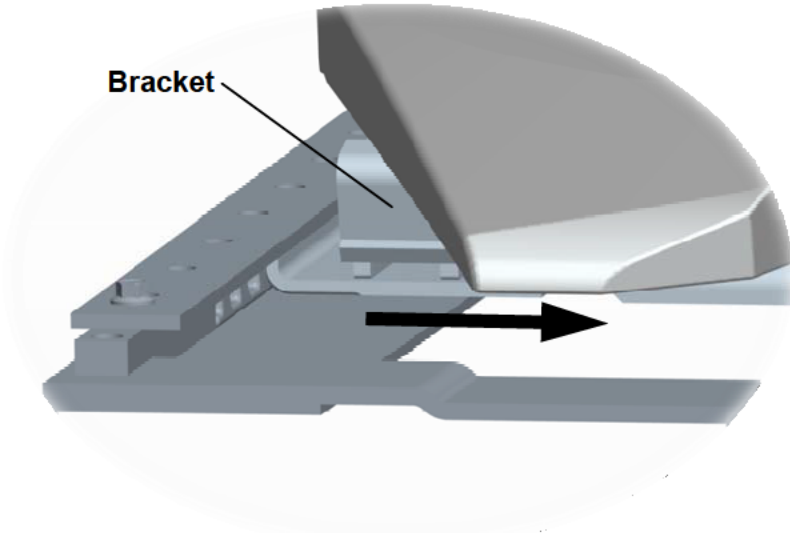

1. Using a pry-bar, force the topplate and bracket over to one side

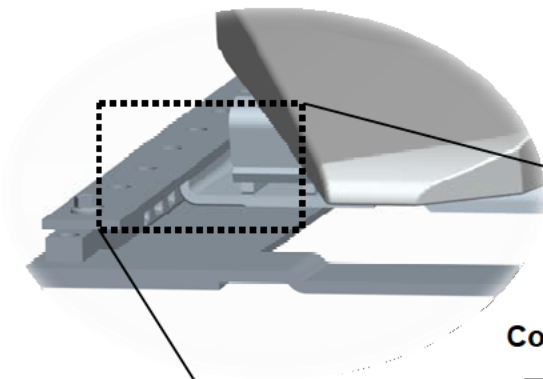

2. Place a ruler or tape measure under the cover to measure the gap between the rack and bracket. A gap of $\frac{1}{2}$ " or more is the unit in question and is to be replaced.

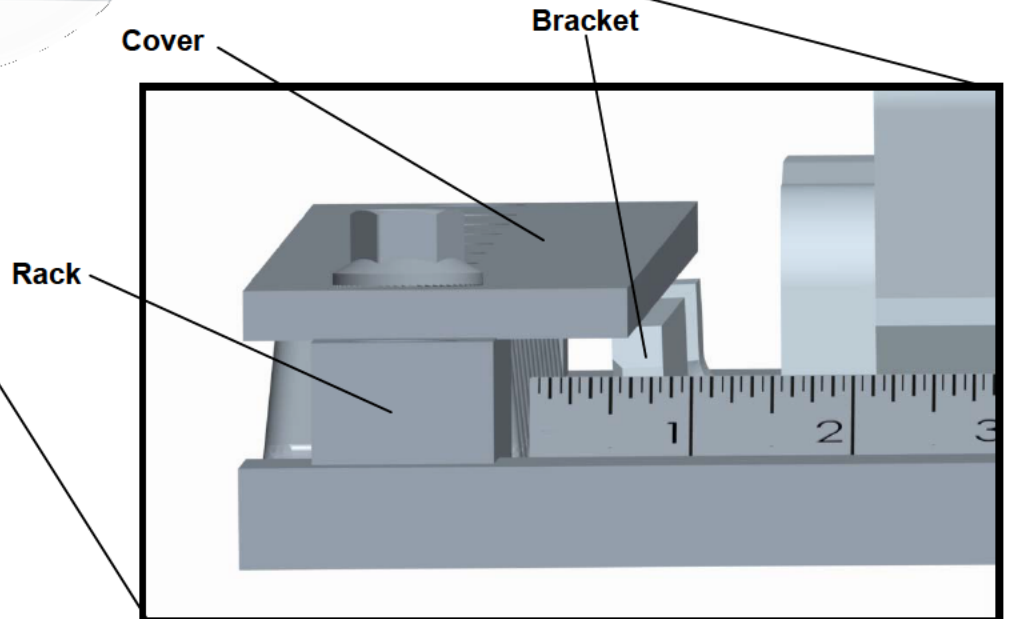



FIELD INSPECTION INSTRUCTIONS For Volvo/Mack Outboard Sliding Fifth Wheels

VIN LIST

Volvo

4V4NC9	4V4NC	4V4WC9	4V4NC9TH	4V4NC9E
4V4NC9	4V4NC	4V4WC9	4V4NC9TH	4V4NC9E
4V4NC9E	4V4NC	4V4WC9	4V4NC9TH	4V4NC9E
4V4NC9E	4V4NC	4V4WC9E	4V4NC9TH	4V4NC9E
4V4NC9E	4V4NC	4V4NC9	4V4NC9TH	4V4NC9E
4V4NC9E	4V4NC	4V4NC9	4V4NC9TH	4V4NC9EH
4V4NC9E	4V4NC	4V4NC9E	4V4NC9T	4V4NC9E
4V4NC9E	4V4NC	4V4NC9	4V4NC9T	4V4NC9E
4V4NC9E	4V4NC	4V4NC9	4V4NC9T	4V4WC9E
4V4NC9E	4V4NC9	4V4NC9E	4V4NC9	4V4NC9E
4V4NC9E	4V4NC9	4V4NC9EH	4V4NC9T	4V4NC9E
4V4NC9E	4V4NC9	4V4NC9E	4V4NC9T	4V4NC9EH
4V4NC9E	4V4NC9	4V4NC9E	4V4NC9T	4V4NC9EH
4V4NC9E	4V4NC9	4V4NC9EJ	4V4WB9	4V4NC9E
4V4NC9	4V4NC9	4V4NC9E	4V4WB9	4V4NC9E
4V4NC9	4V4NC9	4V4NC9E	4V4WB9	4V4NC9E
4V4NC9	4V4NC9	4V4NC9E	4V4WB9	4V4NC9E
4V4NC9	4V4NC9	4V4NC9E	4V4WB9	4V4NC9E
4V4NC9	4V4NC9	4V4NC9E	4V4WB9	4V4NC9E
4V4NC9	4V4NC9	4V4NC9E	4V4WB9	4V4NC9E
4V4NC9	4V4NC9	4V4NC9E	4V4WB9	4V4NC9E
4V4NC9E	4V4NC9	4V4NC9E	4V4WC9E	4V4NC9E
4V4NC9E	4V4NC9	4V4NC9E	4V4WC9	4V4NC9E
4V4NC9EH	4V4NC9	4V4NC9E	4V4NC9E	4V4NC9EH
4V4NC9EH	4V4NC9	4V4NC9E	4V4NC9E	4V4NC9EH
4V4NC9E	4V4NC9T	4V4NC9E	4V4NC9E	4V4NC9EH
4V4NC9E	4V4NC9T	4V4NC9T	4V4NC9E	4V4NC9E
4V4NC9E	4V4NC9T	4V4NC9TH	4V4NC9E	4V4NC9E
4V4NC9E	4V4NC9T	4V4NC9T	4V4NC9E	4V4NC9E
4V4NC9E	4V4NC9T	4V4NC9T	4V4NC9E	4V4NC9E
4V4NC9E	4V4NC9T	4V4NC9	4V4NC9E	4V4NC9E
4V4NC9E	4V4NC9T	4V4NC9	4V4NC9E	4V4NC9E
4V4NC9E	4V4WC9D	4V4NC9	4V4NC9E	4V4NC9E
4V4NC9E	4V4WC9D	4V4NC	4V4NC9E	4V4NC9E
4V4NC9E	4V4WC9D	4V4NC9T	4V4NC9	4V4NC9E

Mack

1M1AN	1M1AN4G	1M1AN4GY	1M1AN4	1M1AN4G
1M1AN2G	1M1AN4GY	1M1AN4GY	1M1AN4G	
1M1AN2G	1M1AN4G	1M1AN4GY	1M1AN4G	
1M1AN3G	1M1AN4G	1M1AN4GY	1M1AN4G	

