



R19ZV

SECOND FINAL NOTICE

DATE: November 5, 2019

TO: Blue Bird Owners

Subject: R19ZV, Vision Transmission Shifter Cable & Brake Line Routing with Ford 6.8L V10 Engines

According to our records, we have not received confirmation that the above referenced recall, dated February 7, 2019, has been completed. A copy of Recall R19ZV is attached. Your buses affected by Recall R19ZV are identified by Blue Bird body number and VIN under Section 2 on the enclosed cover sheet.

If this is the first time you have received notification of Recall R19ZV, please read the enclosed notification carefully. Recall R19ZV must be completed, as soon as possible. To correct this condition, Dealers will install a bracket to insulate the brake lines from heat and reroute the transmission shifter cable away from the fuel lines. Parts can be ordered through campaignparts@blue-bird.com

Blue Bird will reimburse the labor cost of the repairs related to this recall at no cost to you, the vehicle owner. The standard repair time (SRT) to accomplish these repairs in accordance with the R19ZV installation procedure is 0.5 hours.

If you have already had R19ZV performed on your affected buses, please complete and mail the enclosed pink reply sheet to us in the enclosed postage paid pink reply envelope so we may update our recall records. Be sure the reply sheet is filled out properly.

Questions regarding this recall campaign should be directed to me at (478) 822-2242 or campaignparts@blue-bird.com

Thank you for your prompt attention to this matter.

Sincerely,

Lisa Hancock

Corporate Recall Administrator
Blue Bird Corporation
3920 Arkwright Road Suite 200, Macon, Georgia 31210
Phone 478.822.2242
lisa.hancock@blue-bird.com

BLUE BIRD BODY COMPANY
3920 Arkwright Road, Suite 200, Macon, GA 31210 – (478) 825-2021



R19ZV

IMPORTANT SAFETY RECALL NOTICE

**NHTSA Recall Number: 18V-884 School Bus
NHTSA Recall Number: 18V-885 Non-School Bus**

DATE: February 7, 2019

SUBJECT: RECALL R19ZV – Vision Transmission Shifter Cable and Brake Line Routing with Ford 6.8L V10 Engines

Dear Blue Bird Owner:

This important safety recall notice applies to your bus(es) identified by both Blue Bird Body Number and Vehicle Identification Number (VIN) on the enclosed pink reply sheet. If you no longer own the subject bus(es), please complete the appropriate section of the yellow coversheet sheet and return to Blue Bird in the enclosed pink postage prepaid envelope.

This notice is sent to you in accordance with the requirements of the National Traffic and Motor Vehicle Safety Act.

Blue Bird Body Company is recalling certain model year 2013 to 2020 Vision School Buses manufactured from January 24, 2012 through September 27, 2018 and certain model year 2016 to 2020 Vision Non-School Buses manufactured from September 24, 2014 through September 18, 2018. On certain Blue Bird Vision buses equipped with Ford 6.8L V10 engines, the hydraulic brake lines and/or transmission shifter cable may have been incorrectly routed and could come into contact with surrounding components. The brake lines may be routed in close proximity to the exhaust manifold of the engine, which could expose the lines to excessive heat and premature failure causing brake fluid to leak onto the manifold. On gasoline fueled buses, if the transmission shifter cable were to rub against the engine fuel supply line it could result in a fuel leak. Both issues could increase the risk of fire, causing injury and/or damage to property.

To correct this condition, Dealers will install a bracket to insulate the brake lines from heat and reroute the transmission shifter cable away from the fuel lines.

Blue Bird will reimburse the labor cost of the repairs related to this recall at no cost to you, the vehicle owner. The standard repair time (SRT) to accomplish these repairs in accordance with the R19ZV installation procedure is 0.5 hours.

Federal law requires that any vehicle lessor receiving this recall notice must forward a copy of this notice to the lessee within ten days.



BLUE BIRD

Blue Bird Body Company
Page 2

R19ZV

If the modifications directed by this notification were performed on your bus prior to the receipt of this recall notification, attach a copy of the work order/invoice. Mail the documents in the pink self-addressed postage prepaid envelope included with the pink reply sheet to Blue Bird for warranty consideration. Reimbursements will be made in accordance with the requirements of the National Highway Transportation Safety Act, Title 49 Code of Federal Regulations, Parts 573 and 577.

Please contact your local Blue Bird Dealer with any questions regarding this recall campaign.

If Blue Bird Body Company should fail to or is unable to remedy this condition without charge to you, you may contact:

**ADMINISTRATOR
NATIONAL HIGHWAY TRAFFIC SAFETY ADMINISTRATION
1200 NEW JERSEY AVENUE, SE
WASHINGTON, D.C. 20590**

Or, you may call The National Highway Traffic Safety Administration toll free at:
1-888-327-4236 TTY 1-800-424-9153 or go to: <http://www.safercar.gov>



RECALL

R19ZV Revision A Vision Trans Shifter Cable & Brake Line

Models Affected: Certain 2013–2020 Vision’s with Ford 6.8L Engines.

Issue: On certain Blue Bird Vision buses equipped with the Ford 6.8L V10 engines, the hydraulic brake lines or transmission shifter cable may not be routed properly. In certain cases, the brake lines may be routed in close proximity to the exhaust manifold of the engine which could expose the lines to excessive heat and premature failure which could result in hydraulic brake fluid leaking onto the manifold. On other units the transmission shifter cable could contact the gasoline fuel supply line to the engine which may result in a fuel leak.

Corrective Action: Install a heat shield to insulate the brake lines from excessive heat, control routing of the brake lines, and secure the transmission shifter cable away from the fuel line.

WARNING: Always follow all Federal, State, and Local and Shop safety standards and use proper safety equipment, and thoroughly read and understand all instructions before performing these procedures. Park bus on level surface, apply parking brake, turn of ignition key, and chock wheels. Allow unit to cool before working near exhaust system.

Order only one of the following kits according to your Brake Type per unit:
Parts Kit

Brake Type	Kit Number	Description	Quantity	Kit Consists of Items
Hydraulic Brake	10064498	KIT, ROUTING, TRANS SHIFTER CABLE & BRAKE LINE, HYD	1	1-6
Air Brake	10044697	KIT, ROUTING, TRANS SHIFTER CABLE & BRAKE LINE, AIR	1	1-14

Sub Parts/Items Needed:

Item Number	Part Number	Description	Quantity
1	00829390	NUT, HEX HD, 5/16-18, SER WASHER, YEL ZN DICH (Hyd & Air)	2
2	10062357	BRACKET, HEAT SHIELD, HYD BRAKE, FORD CV (Hyd & Air)	1
3	00854414	CAPSCREW, HEX HD, 5/16-18X7/8, GR8, YEL ZN DICH (Hyd & Air)	2
4	10029717	WASHER FLAT 5/16X3/4X5/64, YEL ZN DICH (Hyd & Air)	2
5	00024076	TIE, CABLE, NYLON, BUTTON, HD, 14.75X22W (Hyd & Air)	1
6	00029998	TIE, CABLE, 120LB (Hyd & Air)	2
7	01598630	BRACKET, MTG, HEATER & FREON HOSES, ENGINE QB (Air Only)	1
8	00803239	CAPSCREW, HEX HD, 1/2-13X1 1/2, GR8, YEL ZN DICH (Air Only)	1
9	00850800	NUT, HEX HD, 1/2-13, LOCKING, GRD8, CAD WAX (Air Only)	1
10	00850776	WASHER, FLAT, 17/32X1 1/16X3/32, HDN, BLKZN(Air Only)	2
11	00870477	CAPSCREW, HEX HD, 1/4-20X1, GRD8, YEL ZN DICH(Air Only)	1
12	00030876	2 WAY SADDLE MOUNT S2HM25(Air Only)	1
13	01247709	WASHER, FLAT, .2656 IDX .625 OC, YEL ZN DICH(Air Only)	1
14	01039262	NUT, HEX HD, 1/4-20, LOCK, ZINC(Air Only)	1

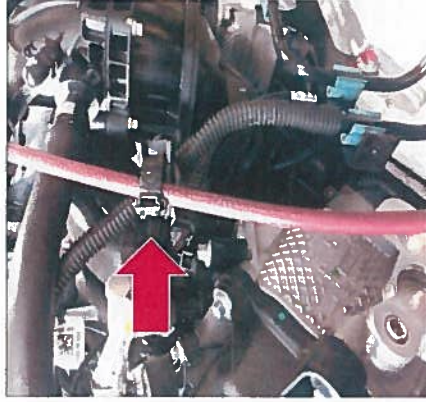

Photo 1



Photo 2

Inspection for Both Hydraulic & Air Brake Units:

Check the transmission shifter cable and insure it is NOT mounted to the top rear of the engine (Photo 1). Also inspect the fuel line to insure the PCV hose is not attached to the fuel line (Photo 2). If so, cut the mounting cable ties and remove ties and mounting saddle. Inspect the fuel line for any chaffing at shifter cable mounting point and replace fuel line if necessary.



RECALL

BLUE BIRD

R19ZV Revision A Vision Trans Shifter Cable & Brake Line

Hydraulic Brake Instructions: (Kit # 10064498)

1. Locate rubber hydraulic brake lines inside the LH frame rail on left side of engine.
 2. Inspect the lines for any defects, such as cracks, deformities, melted areas, and replace if necessary.
- Note: Refer to service manual for fill and bleed procedures.
3. Check the transmission shifter cable and insure it is **NOT** mounted to the top rear of engine (Photo 1). If so, cut the mounting cable tie and remove mounting saddle. Inspect fuel line for any chaffing at shifter cable mounting point and replace fuel line if necessary (Photo 1)
 4. Locate the existing steel brake line L bracket mounted to the inside of the LH frame rail. Remove and retain the hydraulic brake line clamp, two-way saddle and fasteners from the top of the L bracket (Figure 1).
 5. Install heat shield bracket (Item 2) to the top of the L bracket with fasteners (Items 1, 3, 4) and remount the metal brake line clamp under the existing L bracket (Figure 1).
 - Please insure steel brake line is clamped in a parallel line to the frame rail.
 6. Install the previously removed two-way saddle containing the rubber hydraulic brake line to the heat shield using the existing fasteners as shown (Figure 1).
 7. On units with an air compressor, secure the air compressor steel braided line to the heat shield saddle with an additional tie cable (Item 6) separate of hydraulic brake lines as shown (Figure 1).
 - Verify the routing of the braided line to insure no dips in the line with a continuous downward slope to the air dryer.
 8. Secure the transmission shifter cable to the side of the heat shield with button head zip tie (Item 5) as shown (Figure 1).
 9. Once completed be sure to inspect heat shield and shifter cable for any chaffing conditions.

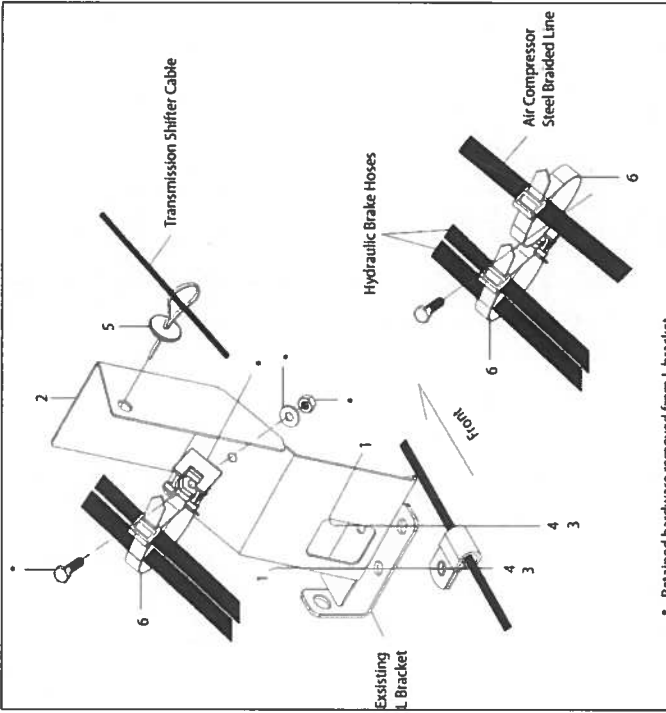

• - Retained hardware removed from L bracket.

Figure 1



RECALL

R19ZV Revision A Vision Trans Shifter Cable & Brake Line

Air Brake with gasline powertrain. Instructions: (Kit # 10064497)

1. Locate and remove lower rearward Huck fastener from driver's side outrigger bracket. Indicated with small red arrow (Figure 2).
2. Install L bracket (Item 7) with fasteners (Items 8, 9, 10) on the inside of frame rail in the location of the removed Huck fastener. Torque to 56-58 ft lbs.
3. Install heat shield bracket (Item 2) to the top of the L bracket with fasteners (Items 1, 3, 4) as shown (Figure 3).
4. Install Saddle (Item 12) to the heat shield with fasteners (Items 11, 13, 14) as shown. Secure the air compressor steel braided line to the heat shield saddle using Zip Tie (Item 6) as shown (Figure 3).
 - Verify the routing of the braided line to insure no dips in the line with a continuous downward slope to the air dryer.
5. Secure the transmission shifter cable to the side of the heat shield with button head zip tie (Item 5) as shown in (Figure 3).
6. Once completed be sure to inspect heat shield and shifter cable for any chaffing conditions.

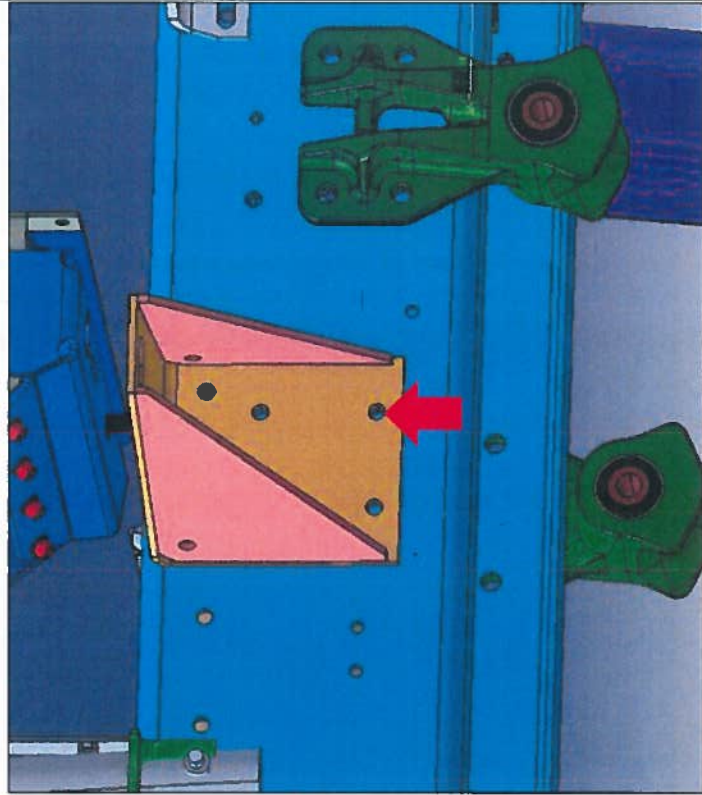

Figure 2

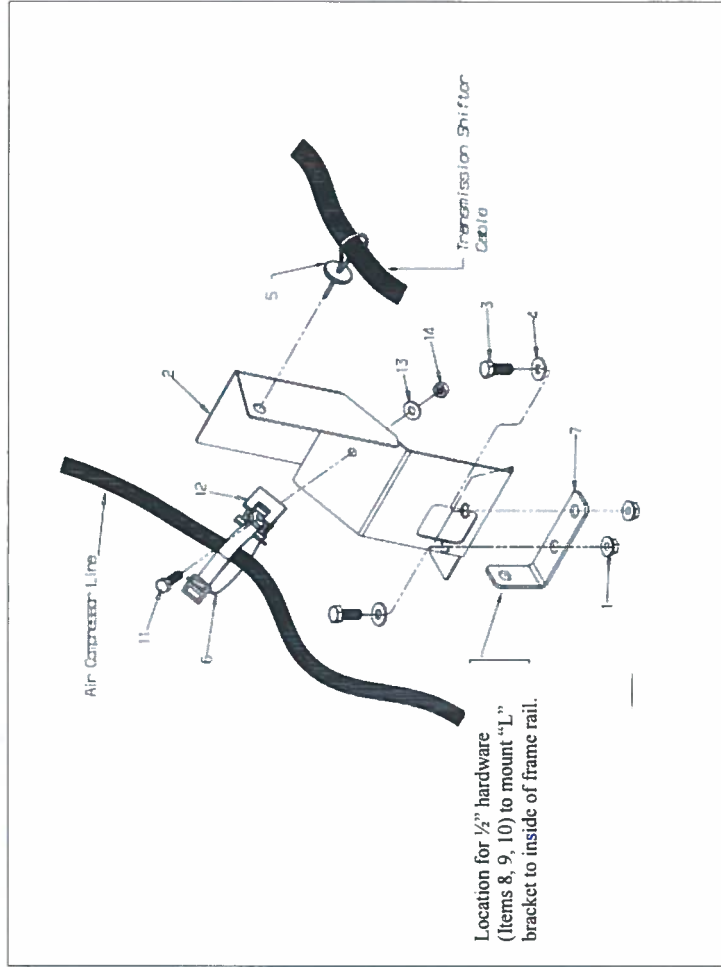

Figure 3