



**SAFETY  
RECALL**

**SR19-04A**


DATE :	June 2019	SECTION : 14 STEERING
SUBJECT:	<b>DRAG LINK REPLACEMENT</b>	

Revision: A

Added inspection step, instructions for reimbursement

2019-06-07

**APPLICATION**

<b>NOTICE TO SERVICE CENTERS</b> <i>Verify vehicle eligibility by checking warranty bulletin status with <b>SAP</b> or via <b>ONLINE WARRANTY SYSTEM</b> available on Service / Warranty tab of PrevoSt website.</i>	
Model	VIN 
Le Mirage XLII coaches Model Year: 2000 - 2006	Vehicles equipped with I-beam Axles From 2PCX3349XY1 [REDACTED] up to 2PCX33493 [REDACTED] 6 incl.
X3-45 coaches Model Year: 2007 - 2014	Vehicles equipped with I-beam Axles From 2PCG334987 [REDACTED] up to 2PCG33495EC7 [REDACTED] incl.
<b>This Safety Recall does not necessarily apply to all the above-mentioned vehicles, some vehicles may have been modified before delivery. The owners of the vehicles affected by this recall will be advised by a letter indicating the Vehicle Identification Number (VIN) of each vehicle concerned.</b>	

**DESCRIPTION**

On the vehicles involved equipped with I-beam axles, cracks can occur and propagate in the steering draglink turnbuckle under certain conditions. If the cracks start to propagate, over time it may extend inward to a point where the turnbuckle may fracture.

If the turnbuckle fractures, a complete loss of steering would occur that can increase the risk of a vehicle crash or other risks associated with a disabled vehicle.

Inspect the draglink and if required, replace the complete draglink by an improved part.

Please note that vehicles equipped with independent front suspension (*IFS*) are excluded from this recall

## MATERIAL

Order kit SR19-04 which includes the following parts:

Part No.	Description	Qty
660699	DRAG LINK ASSEMBLY	1
502104	COTTER PIN 5/32X2	2

Other parts that may be required:

Part No.	Description	Qty
660018	COLLAR ASSY W/ BOLT & NUT	1

***NOTE***

*Material can be obtained through regular channels.*

## PROCEDURE



### DANGER

Park vehicle safely, apply parking brake, stop engine. Prior to working on the vehicle, set the ignition switch to the OFF position and trip the main circuit breakers equipped with a trip button. On Commuter type vehicles, set the battery master switch (master cut-out) to the OFF position.

### INSPECTION PRIOR TO PERFORMING RECALL

1. This recall involves a former draglink design with a turnbuckle near the pitman arm.(Figure 1)
2. Open the front service compartment and pull on the front bumper release. The pitman arm and steering draglink can be found on the driver's side.
3. The recalled draglink is identifiable by the presence of a *turnbuckle* and *two clamps* in the section nearest to the pitman arm. (Figure 1)
4. If it is confirmed your vehicle has the recalled draglink (Figure 1), you may proceed to the replacement.
5. If your vehicle does not have the recalled draglink design, please read further for *additional instructions*.

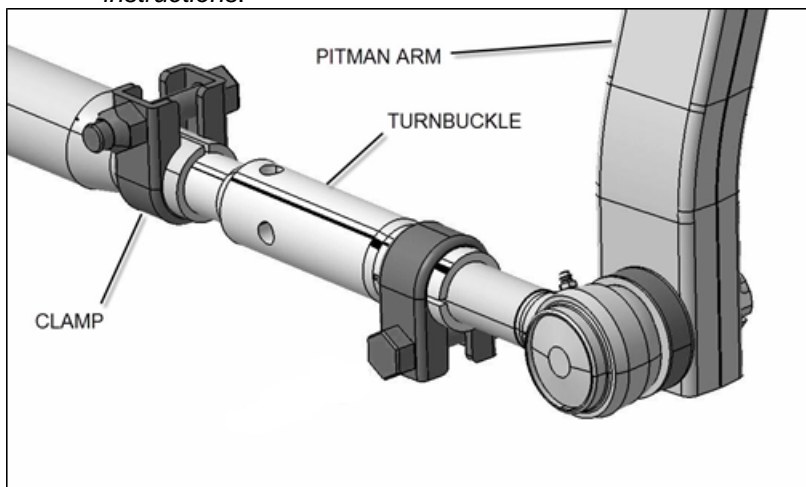


Figure 1: Recalled draglink with turnbuckle and two clamps.

---

**Additional instructions for vehicles without the recalled draglink installed:**

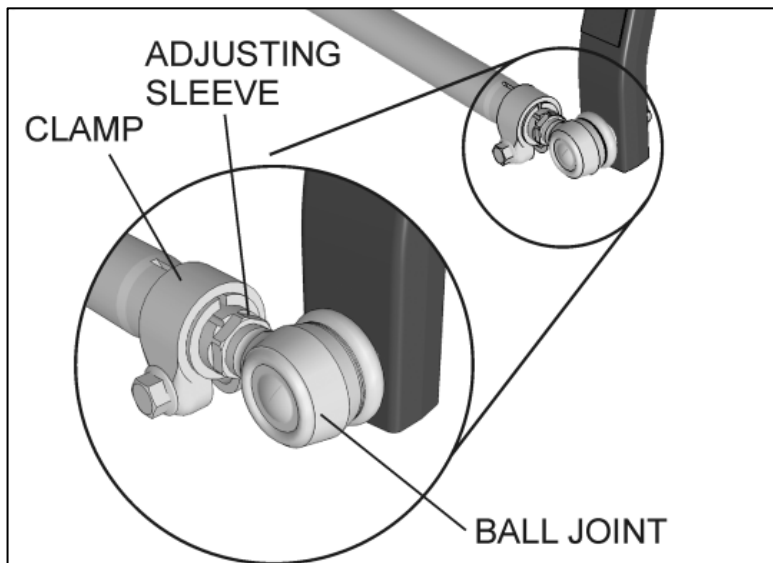
Some vehicles may already have installed the improved design draglink 660699 by having performed **IS-13009** (kit number 161458).

The improvement can be confirmed by the presence of an *adjusting sleeve* and a *single clamp* in the section nearest to the pitman arm. (Figure 2)

If the vehicle already has this draglink, this is the improved part being installed in the recall. *You do not have to perform the replacement.*

However, if you have paid for this exact replacement in the past and have received a recall notification letter from Prevest, you may be eligible for a reimbursement. Please submit an online warranty claim using SR19-04 and supply the following additional information:


- Date of replacement
- Prevest Parts purchase order number
- or
- Prevest Service center repair order number.



**Figure 2: Improved 660699 draglink**

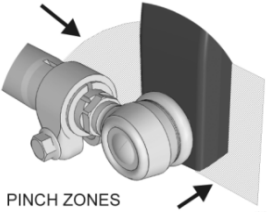
---

## SAFETY PRECAUTIONS



### PINCH HAZARD

Keep hands and fingers clear of pinch zones around pitman arm.  
Pinch zones are between pitman arm and clamp, and between front of pitman arm and vehicle structure.



PINCH ZONES

## REMOVAL OF EXISTING DRAG LINK

1. Raise the vehicle by the wheels using mobile column lifts. Doing so will prevent a change in direction of the knuckles and preserve the relative positions of the steering components involved in this procedure.
2. Remove cotter pin and nut from drag link ball joint stud at pitman arm.
3. Disconnect drag link from pitman arm, using jaw style pullers (pressure screw type).



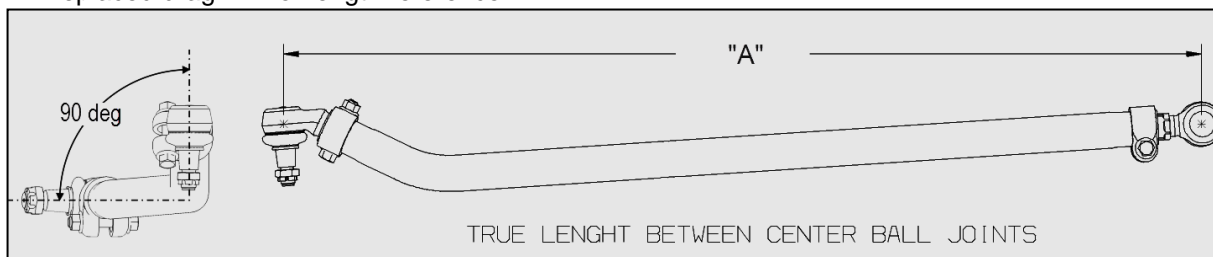
### CAUTION

Heating of components to aid in disassembly is not allowed because it has a detrimental effect on axle components and steering linkages.

4. Remove cotter pin and nut from drag link ball joint stud at the steering arm (near knuckle) and then disconnect the drag link.
5. Keep the original drag link for length reference.

## ADJUSTING THE DRAG LINK TO PROPER LENGTH - ELBOW BALL JOINT (KNUCKLE SIDE)

6. Check if the pre-adjusted length of the drag link is correct. To do so, try to install it between the steering arm and the pitman arm. If the length is not adequate, it must be adjusted to the required length. Use dimension "A" to adjust the length of the replacement drag link or you may use the replaced drag link for length reference.



**FIGURE 3**

Length A = 52" 3/8" ± 1/16" (1330mm ± 2mm)

7. Screw the drag link elbow ball joint (knuckle side) fully in drag link tube.



FIGURE 4

8. Unscrew the drag link *elbow ball joint* by no more than 1 turn so the tapered shank *points down* as shown on. (FIGURE 5)

This will be the *initial reference position* for next step.



FIGURE 5

9. From the *initial reference position*, unscrew the drag link elbow ball joint back out **one (1) full turn**.

The tapered shank must point down as shown on.(FIGURE 6)



FIGURE 6

10. To prevent interference between the ball joint clamp bolts and other components of the steering system, the clamp bolt must be positioned vertically as shown on FIGURE 7. **Tighten the clamp nut to 118-133 lbf-ft.**



### CAUTION

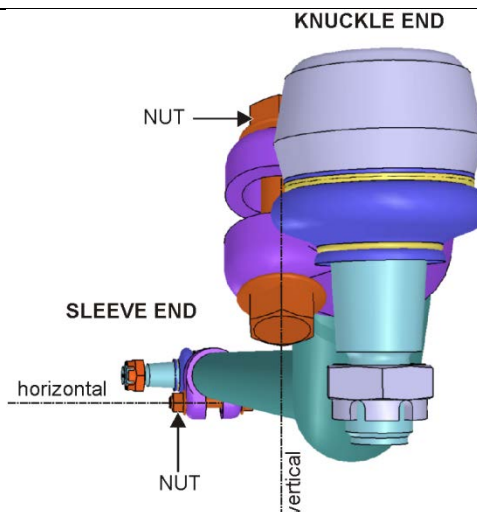
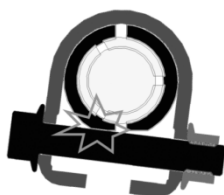
**Do not re-use clamp hardware.**

Bolt and nut should be replaced every time they are unscrewed. Use collar assembly 660018.



### CAUTION

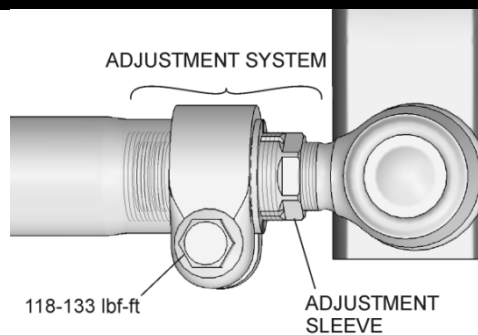
While assembling the clamp, make sure the bolt does not touch the drag link tube.



**FIGURE 7: NOTE THE VERTICAL ORIENTATION OF THE CLAMP BOLT AT THE KNUCKLE END AND ON WHICH SIDE THE NUT MUST BE POSITIONED**

## SLEEVE ADJUSTMENT PARAMETERS

11. On the drag link front end you will find an adjustment sleeve which has internal and external left and right threads.

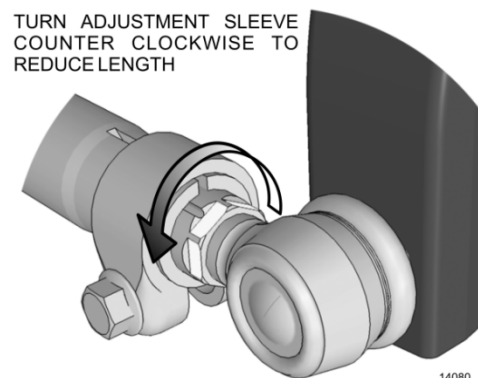


**FIGURE 8**

12. Fine adjustment of the drag link length if required should be performed exclusively by turning the adjustment sleeve while preventing the tube and joint from rotating.

***The only part rotating should be the sleeve***

- To extend, turn the sleeve clockwise.
- To retract, turn counter clockwise.

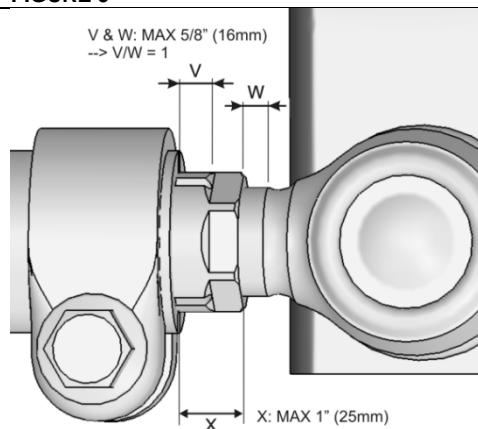


**FIGURE 9**

### GENERAL LIMITATIONS OF THE ADJUSTMENT SLEEVE

Do not exceed the following maximum thread lengths and values.

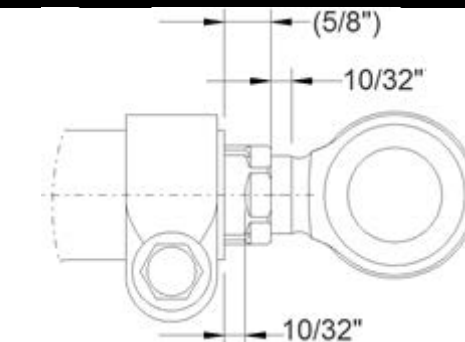
- Max dimension **V** : 5/8" (16mm) ± 1 thread pitch
- Max dimension **W** : 5/8" (16mm) ± 1 thread pitch
- Max dimension **X** : 1" (25mm)
- Dimension **V** and **W** should be equal. ( $V/W = 1$ )



**FIGURE 10**

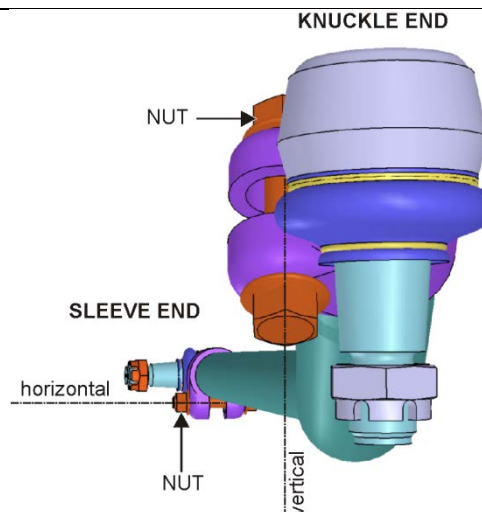
## SLEEVE ADJUSTMENT

13. Adjust sleeve to the values of FIGURE 11.
14. Once the proper length adjustment is done, tighten the front end ball joint clamp. To prevent interference between the ball joint clamp bolts with other components of the steering system, the clamp bolt must be positioned horizontally as shown in FIGURE 12. **Tighten the clamp nut to 118-133 lbf-ft.**
15. Apply a torque seal mark



**FIGURE 11**

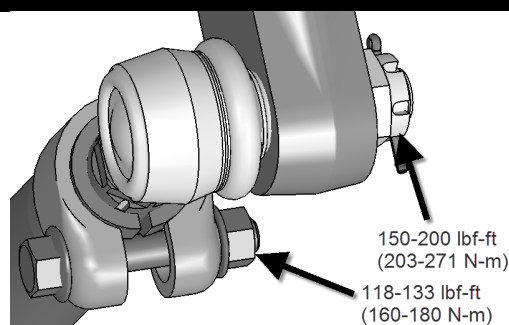
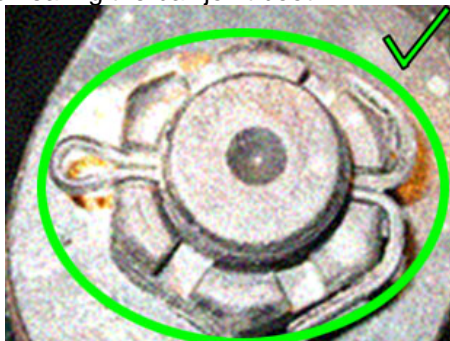




**FIGURE 12: NOTE THE HORIZONTAL ORIENTATION OF THE CLAMP BOLT AT THE SLEEVE END AND ON WHICH SIDE THE NUT MUST BE POSITIONED**

### DRAG LINK INSTALLATION

16. Install the drag link.
17. Ball joint castellated nut on both ends should be tightened to **150-200 lbf-ft.**
18. Install cotter pin p/n 502104 and bend to lock bolt in place (see example in image below).
19. Apply a small amount of anti-seize compound on all exposed threads for corrosion protection. Be sure to avoid smearing the ball joint boot.



**FIGURE 13**

20. Make sure there is no binding or interference of the draglink with the vehicle structure by turning wheels fully in each direction. Min gap: 1/4" (6mm)
21. Inspect the gap between *tire* and *draglink*, turning wheels *right*. Min gap 3/8" (9.5mm).

## PARTS DISPOSITION

DO NOT RETURN THE REPLACED PARTS. Discard waste according to applicable environmental regulations (Municipal/State[Prov.]/ Federal)

## WARRANTY

This modification is covered by Prevost's normal warranty. We will reimburse fifteen minutes (15 min) for *inspection only* or we will reimburse you the parts and two and a half hours (2.5h) of labor for *inspection and replacement* upon receipt of a completed A.F.A.

If you already have performed this improvement on your vehicle, you may be entitled to recovery of those expenses. Refer to "Inspection Prior to Performing Recall" and "Additional Instructions" on pages 3 and 4. Provide the requested additional information. We will reimburse fifteen minutes (15 min) for the inspection under this recall.

Please submit claim via our Online Warranty System, available at [www.prevostcar.com](http://www.prevostcar.com) (under service \ warranty section). Use Claim Type: "Bulletin/Recall" and select "Safety Recall SR19-04".

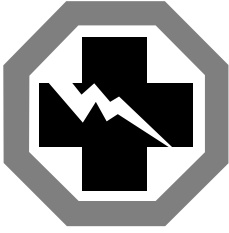
Should you only wish to close the safety recall (without reimbursement), fill-in the "Safety Recall Certification Sheet" provided with this bulletin and return it to our warranty department by Email at [prevost.onlinewarranty@volvo.com](mailto:prevost.onlinewarranty@volvo.com) or by fax at 418-831-9301.

## OTHER

VBC Bulletin	N/A
Fail Code	14.04
Defect Code	09
Syst.Cond	R
Causal Part	160932

Access all our Service Bulletins on <http://techpub.prevostcar.com/en/> or scan the QR-Code with your smart phone. E-mail us at [technicalpublications\\_prev@volvo.com](mailto:technicalpublications_prev@volvo.com) and type "ADD" in the subject to receive our warranty bulletins by e-mail.





**Safety Recall  
Certification Sheet  
(Ref: SR19-04)**

**VEHICLE SERIAL NUMBER:**

2	P	C																	
---	---	---	--	--	--	--	--	--	--	--	--	--	--	--	--	--	--	--	--

PERFORMED BY		OWNER/OPERATOR	
We hereby certify that Safety Recall Instructions with regard to Safety Recall SR19-04 have been performed.			
Name: _____		Name: _____	
Addr: _____		Addr: _____	
Phone: _____		Phone: _____	
Fax: _____		Fax: _____	
Signature : _____	_____	Signature : _____	_____
Date: _____	_____	Date: _____	_____

**If the information mentioned above is incorrect or you are not the owner of this vehicle anymore, please fill this section and return to sender.**

**NEW OWNER:** \_\_\_\_\_

**BUSINESS:** \_\_\_\_\_

**ADDRESS (including County):** \_\_\_\_\_

\_\_\_\_\_

\_\_\_\_\_

**TELEPHONE:** \_\_\_\_\_ **FAX:** \_\_\_\_\_

**Please return this completed document with your A.F.A. form**