

Europe Market

Contact the Service and Customization Consultant.

India Market

Contact the Service and Customization Consultant.

Mexico Market

Contact the local service area representative at Harley-Davidson Mexico.

Japan Market

Contact the local service department at HDJ.

Required Dealer Action

1. Verify that vehicle is part of recall 0174.

Refer to: **H-Dnet > FAVORITES > MY TOOLBOX > Vehicle Information**

- a. Insert the vehicles VIN (Vehicle identification number), click SEARCH.
2. Replace the calipers by following the service manual for the year and model of the vehicle this bulletin is being applied to.

Dealer Inventory Instructions

If dealers have old caliper inventory. Refer to Table 5.

File a DFS/PAM - Stock claim and replace with **new** part. Refer to Table 6.

Table 5. Caliper Replacement Part Numbers

Year	Models	Old Front		Old Rear	New Front		New Rear
		Left	Right		Left	Right	
2016 - 2019	XG500, XG750	41300158	N/A	41300159	41300158A	N/A	41300159A
2017 - 2019	XG750A	41300158	41300190	41300159	41300158A	41300190A	41300159A

Table 6. All Inventory Claims

ITEM	DATA
Claim Type	DFS/PAM - Stock
Problem Part Number	41300158, 41300159, 41300190
Quantity	Could Vary
Customer Concern Code	8101
Condition Code	1116

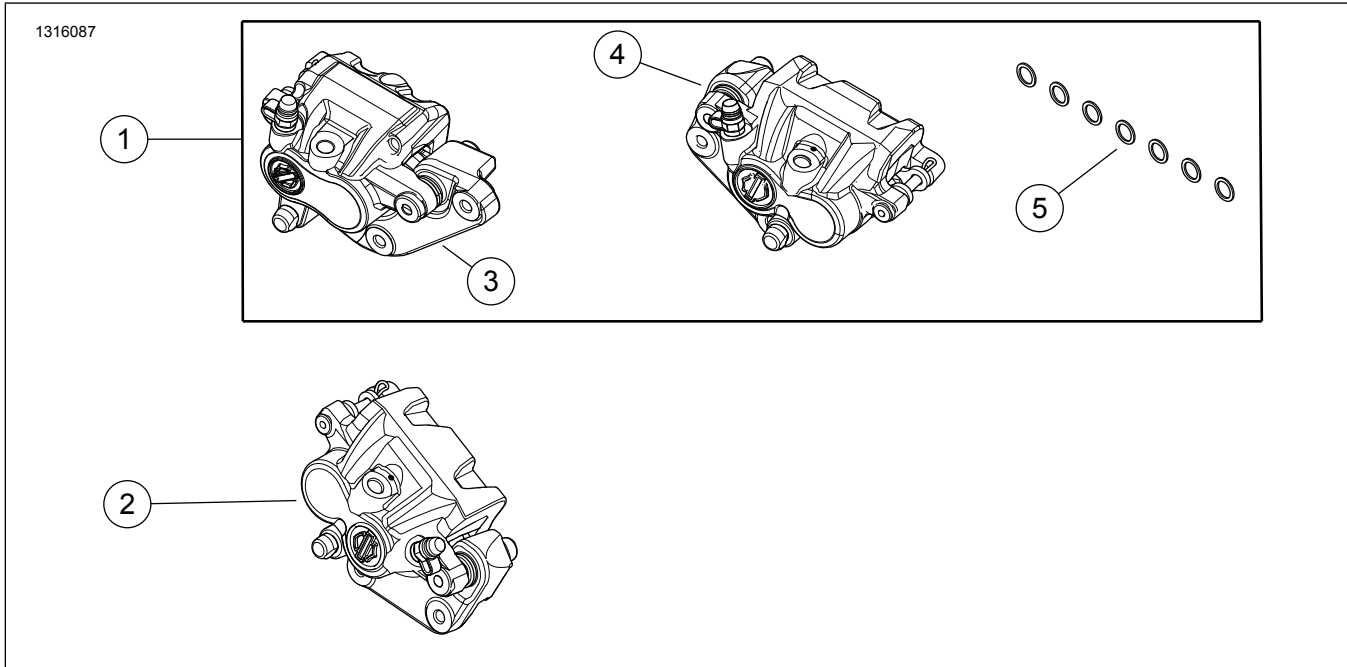

Figure 1. Recall Caliper Kits

Table 7. Recall Caliper Kits

Models	Item	Kit	Kit Items	Qty	Description	Part No.
500, 750, 750A	1	91500097	3	1	Left front caliper	41300158A
			4	1	Rear caliper	41300159A
			5	7	Banjo washers ⁽¹⁾	12300033
750A ⁽²⁾	2	91500098	2	1	Right front caliper	41300190A

(1) Installing kit 91500097 uses four washers, installing kit 91500098 uses three washers. There will be three extra washers after installation of kit 91500097 only.

(2) Both kits 91500097 & 91500098 must be installed on 750A models.

DOT 4 Brake Fluid

All vehicles receive a bottle of DOT 4 Platinum Brake Fluid supplied by the dealer. Refer to Table 8.

Table 8. DOT 4 Platinum Brake Fluid

Description	Part Number Regions
DOT 4 Platinum Brake Fluid	41800770 U.S., Mexico, South America
	91500091 Canada
	41800772 Asia Pacific
	41800773 EMEA
	41800774 Russia

Credit Procedure

Submit a claim for each motorcycle serviced in this bulletin for which VIN involvement was verified on H-Dnet.com.

XG500/750 Models Without ABS

Credit Procedure: Talon/h-dnet.com Warranty Claim System Users

Table 9. XG500/750 Models Without ABS

ITEM		DATA
Claim Type		SRC
Problem Part Number		41300159
Quantity		Leave Blank
Primary Labor Code ⁽¹⁾		2722
Time		0.8 h
Customer Concern Code ⁽¹⁾		0174
Condition Code		9981
Replacement Part No.	U.S., Mexico, South America	91500097 and 41800770
	Canada	91500097
Quantity		1

(1) Download may be required.

Credit Procedure: SAP System Users

Table 10. XG500/750 Models Without ABS

ITEM	DATA
Claim Type	Recall Claim
Fix ID-Found in Recall Number	C
Problem Part Number	41300159
Customer Concern Code	0174
Condition Code	9981

Credit Procedure: All Other System Users

- **Claim Date:**
- **Campaign Number (0174):** 0.8 h
- **FIX ID:** C
- **Full Seventeen Character VIN:**

Upon submission of the properly completed claim, dealers are credited 0.8 h of labor time for performing the procedure, plus appropriate administrative time. Credit will also be issued for the recall kit (U.S. only). Submit campaign events on their own warranty claim. Do not mix them with other warranty events.

XG500/750 Models With ABS

Credit Procedure: Talon/h-dnet.com Warranty Claim System Users

Table 11. XG500/750 Models With ABS

ITEM		DATA
Claim Type		SRC
Problem Part Number		41300159
Quantity		Leave Blank
Primary Labor Code ⁽¹⁾		2734
Time		1.2 h
Customer Concern Code ⁽¹⁾		0174
Condition Code		9982
Replacement Part No.	U.S., Mexico, South America	91500097 and 41800770
	Canada	91500097
Quantity		1

(1) Download may be required.

Credit Procedure: SAP System Users

Table 12. XG500/750 Models With ABS

ITEM	DATA
Claim Type	Recall Claim
Fix ID-Found in Recall Number	R
Problem Part Number	41300159
Customer Concern Code	0174
Condition Code	9982

Credit Procedure: All Other System Users

- **Claim Date:**
- **Campaign Number (0174):** 1.2 h
- **FIX ID:** R
- **Full Seventeen Character VIN:**

Upon submission of the properly completed claim, dealers are credited 1.2 h of labor time for performing the procedure, plus appropriate administrative time. Credit will also be issued for the recall kit (U.S. only). Submit campaign events on their own warranty claim. Do not mix them with other warranty events.

750A Models Without ABS

Credit Procedure: Talon/h-dnet.com Warranty Claim System Users

Table 13. 750A Models Without ABS

ITEM	DATA
Claim Type	SRC
Problem Part Number	41300159
Quantity	Leave Blank
Primary Labor Code ⁽¹⁾	2746
Time	1 h
Customer Concern Code ⁽¹⁾	0174
Condition Code	9983
Replacement Part No.	U.S., Mexico, South America
	Canada
Quantity	1

(1) Download may be required.

Credit Procedure: SAP System Users

Table 14. 750A Models Without ABS

ITEM	DATA
Claim Type	Recall Claim
Fix ID-Found in Recall Number	F
Problem Part Number	41300159
Customer Concern Code	0174
Condition Code	9983

Credit Procedure: All Other System Users

- **Claim Date:**
- **Campaign Number (0174):** 1 h
- **FIX ID:** F
- **Full Seventeen Character VIN:**

Upon submission of the properly completed claim, dealers will be credited 1 h of labor time for performing the procedure, plus appropriate administrative time. Credit will also be issued for the recall kit (U.S. only). Submit campaign events on their own warranty claim. Do not mix them with other warranty events.

750A Models With ABS

Credit Procedure: Talon/h-dnet.com Warranty Claim System Users

Table 15. 750A Models With ABS

ITEM	DATA
Claim Type	SRC
Problem Part Number	41300159
Quantity	Leave Blank
Primary Labor Code ⁽¹⁾	2754
Time	1.4 h
Customer Concern Code ⁽¹⁾	0174
Condition Code	9984
Replacement Part No.	U.S., Mexico, South America
	Canada
Quantity	1 (each)

(1) Download may be required.

Credit Procedure: SAP System Users

Table 16. 750A Models With ABS

ITEM	DATA
Claim Type	Recall Claim
Fix ID-Found in Recall Number	A
Problem Part Number	41300159
Customer Concern Code	0174
Condition Code	9984

Credit Procedure: All Other System Users

- **Claim Date:**
- **Campaign Number (0174):** 1.4 h
- **FIX ID:** A
- **Full Seventeen Character VIN:**

Upon submission of the properly completed claim, dealers will be credited 1.4 h of labor time for performing the procedure, plus appropriate administrative time. Credit will also be issued for the recall kit (U.S. only). Submit campaign events on their own warranty claim. Do not mix them with other warranty events.

Return Parts

Hold all claimed parts for 60 d from date of credit issued for possible field inspection and/or request to return to factory. After 60 d, destroy and discard the parts.