

TECHNICAL INSTRUCTIONS

FOR

SAFETY RECALL JS5

PASSENGER AIRBAGS COULD DEACTIVATE

CERTAIN 2008 – 2019 LANDCRUISER

The repair quality of covered vehicles is extremely important to Toyota. All dealership technicians performing this recall are required to successfully complete the most current version of the E-Learning course “Safety Recall and Service Campaign Essentials”. To ensure that all vehicles have the repair performed correctly; technicians performing this recall repair are required to currently hold at least one of the following certification levels:

- Certified Technician (any specialty)
- Expert Technician (any specialty)
- Master Technician
- Master Diagnostic Technician

It is the dealership’s responsibility to select technicians with the above certification level or greater to perform this recall repair. Carefully review your resources, the technician skill level, and ability before assigning technicians to this repair. It is important to consider technician days off and vacation schedules to ensure there are properly trained technicians available to perform this repair at all times.

I. OPERATION FLOW CHART

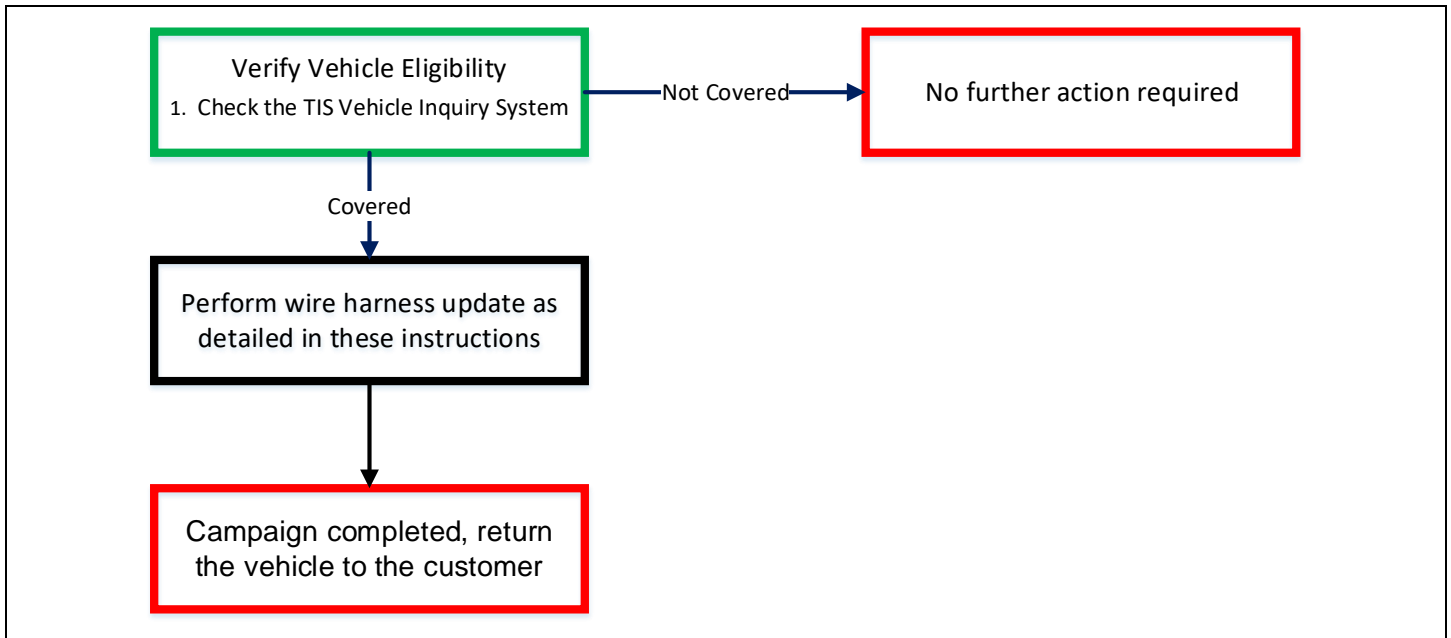

II. IDENTIFICATION OF AFFECTED VEHICLES

- Check the TIS Vehicle Inquiry System to confirm the VIN is involved in this Campaign, and that it has not already been completed prior to dealer shipment or by another dealer.
- TMNA warranty will not reimburse dealers for repairs completed on vehicles that are not affected or were completed by another dealer.

III. PREPARATION

A. PARTS

Toyota will ship Wire Harness Modification kits to dealers throughout the month of February 2019. The quantity of kits shipped is calculated based upon a combination of vehicle registration, last servicing dealer, and retail dealer. These kits are not available through the normal parts system.

The Wire Harness Modification kit will include the following:

- Rubber Cushion
- Zip Tie
- Braided Wire Harness tube

In addition to the parts kit, a roll of Tessa 51036 Abrasion Resistant Tape is also required. Each dealership received this required tape for use in Safety Recall J0T. The dealer will also need to supply a small of standard black vinyl electrical tape.

B. TOOLS & EQUIPMENT

- Techstream
- Standard Hand Tools
- Scissors
- Seam Ripper
- Torque Wrench

C. MATERIALS

- Vinyl Electrical Tape
- Tessa 51036 Abrasion Resistant Tape

IV. BACKGROUND

The front passenger occupant classification system has a seatbelt tension sensor that could malfunction over time and could cause the airbag warning light and the passenger airbag "OFF" indicator to illuminate. In addition, the front passenger airbag, passenger knee airbag, and the passenger seat-mounted side airbag may be deactivated. If these airbags are deactivated, there is an increased risk of injury to the occupant in the event of a crash.

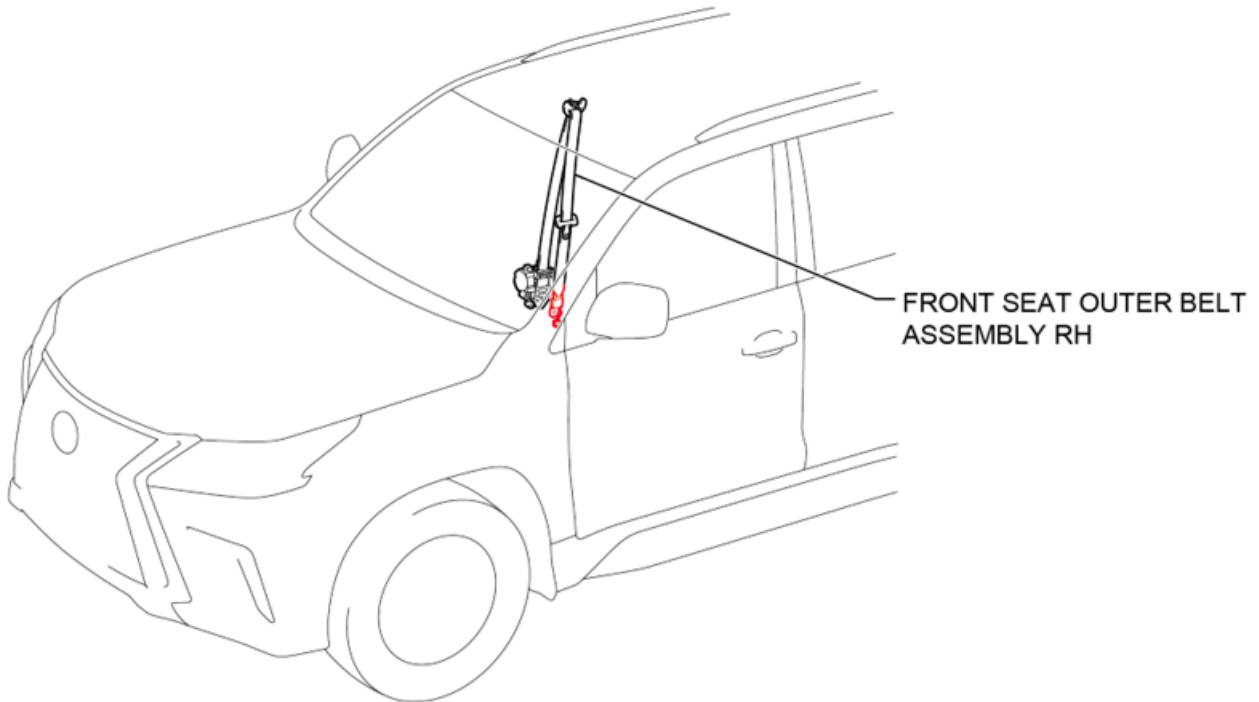

V. COMPONENTS

Vehicles Subject to Front Seat Outer Belt (RH side) Wire Harness Modification:

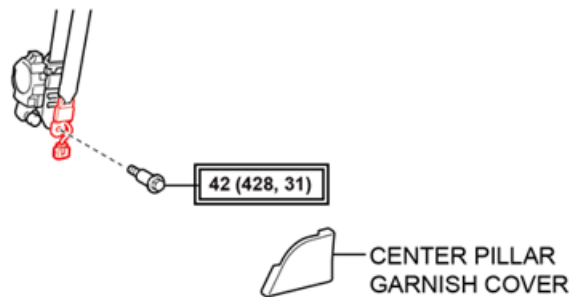

N*m (kgf*cm, ft.*lbf) : Specified torque

[] : Tightening torque for "Major areas involving basic vehicle performance such as moving/turning/stopping" : N*m (kgf*cm, ft.*lbf)

VI. REPAIR PROCEDURE

1. VERIFY THAT THE VEHICLE IGNITION IS IN THE OFF POSITION.
2. ADJUST FRONT RH SEAT POSITION
 - a. Slide the RH front seat fully forward.
 - b. Position RH front seatback to the vertical position.

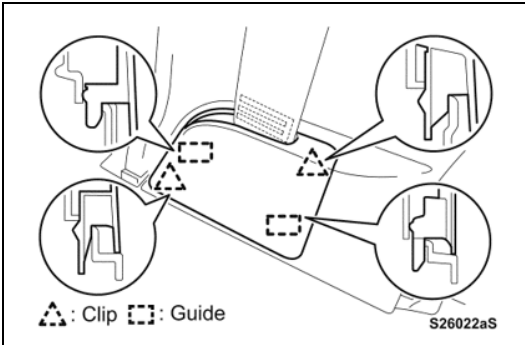

3. REMOVE CENTER PILLAR GARNISH COVER RH
 - a. Pull vertical (straight up) on the RH garnish cover at the base of the B-pillar to detach the 2 clips and 2 guides.

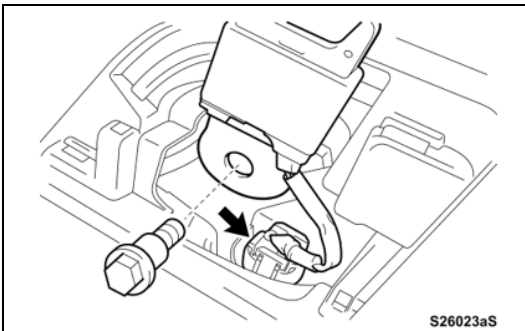

4. REMOVE SEAT BELT ANCHOR
 - a. Disconnect the electrical connector.
 - b. Remove the bolt and seat belt anchor.

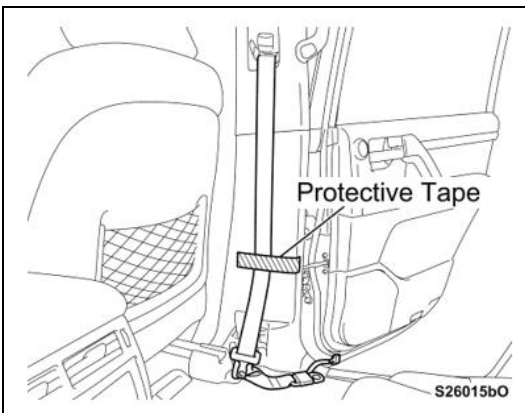

5. MODIFY SEAT BELT TENSION SENSOR
 - a. Extend the seat belt about 24".
 - b. Apply some protective painters tape to hold the belt in position.

Note: Be sure to use a tape that will not leave any residue when removed.

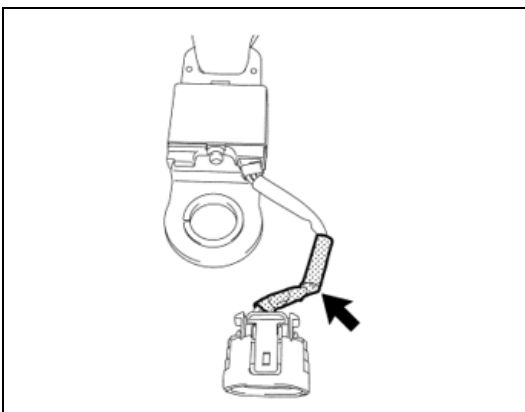

- c. Unravel the vinyl tape from the outer end of the tube.



BE CAREFUL. DO NOT DAMAGE THE WIRES.

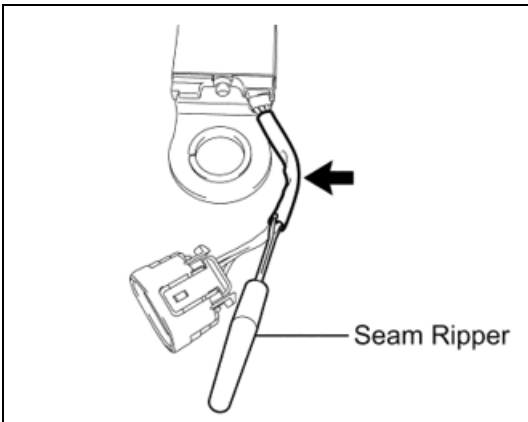

d. Using a seam ripper, carefully slice the black vinyl tube to remove it from the harness.



BE CAREFUL. DO NOT DAMAGE THE WIRES.

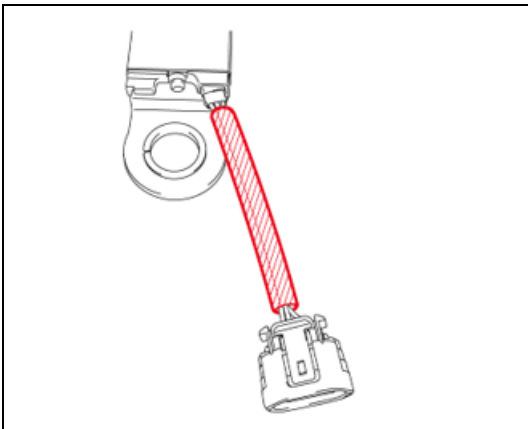

e. Install the **NEW** braided wire harness tube.

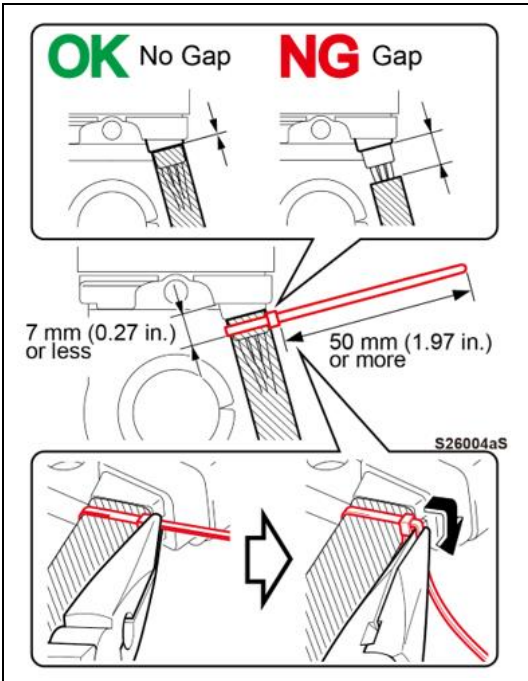

- f. Slide the **NEW** braided harness tube over the base of the seat belt tension sensor as shown in the illustration.
- g. Wrap the **NEW** zip-tie around the harness and tighten in the position as shown.
- h. Using pliers, continue to tighten the zip-tie until the excess tail length is 50mm (1.97”) or longer.
- i. Cut off the excess tail of the zip-tie.

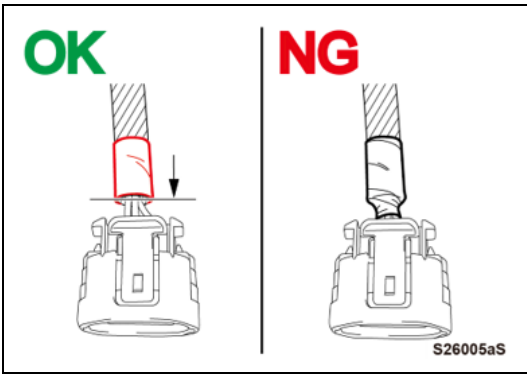

j. Cut a piece of vinyl (electrical) tape and wrap it around the end of the braided harness tube, as shown.

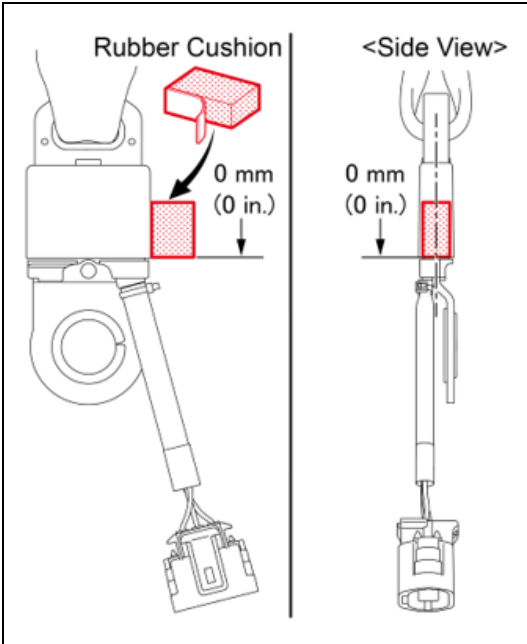

k. Peel the backing paper from the back of the **NEW** rubber cushion.
 l. Attach the **NEW** rubber cushion on the side of the seat belt tension sensor as shown in the illustration.

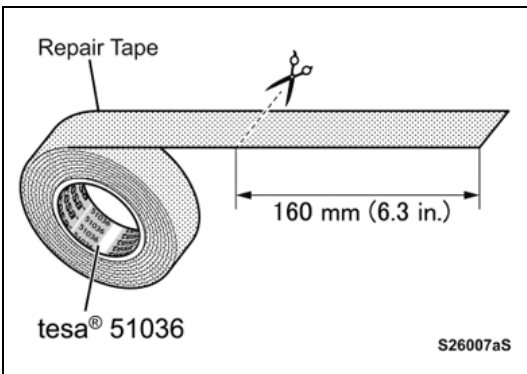

m. Cut a piece of the Tessa 51036 Abrasion Resistant tape to a length of approximately 160mm (6.3”).

Note: The Tessa 51036 Abrasion Resistant tape has been shipped to your dealership to the attention of the Service Manager. This is the same tape used for Safety Recall J0T.

- n. Wrap the Tessa Abrasion Resistant tape around the seat belt tension sensor and the rubber cushion, starting from the rear edge, as shown in the following illustration.

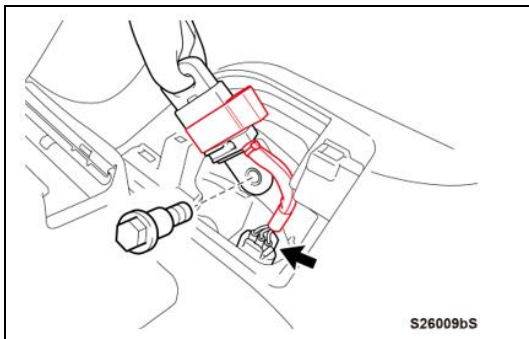
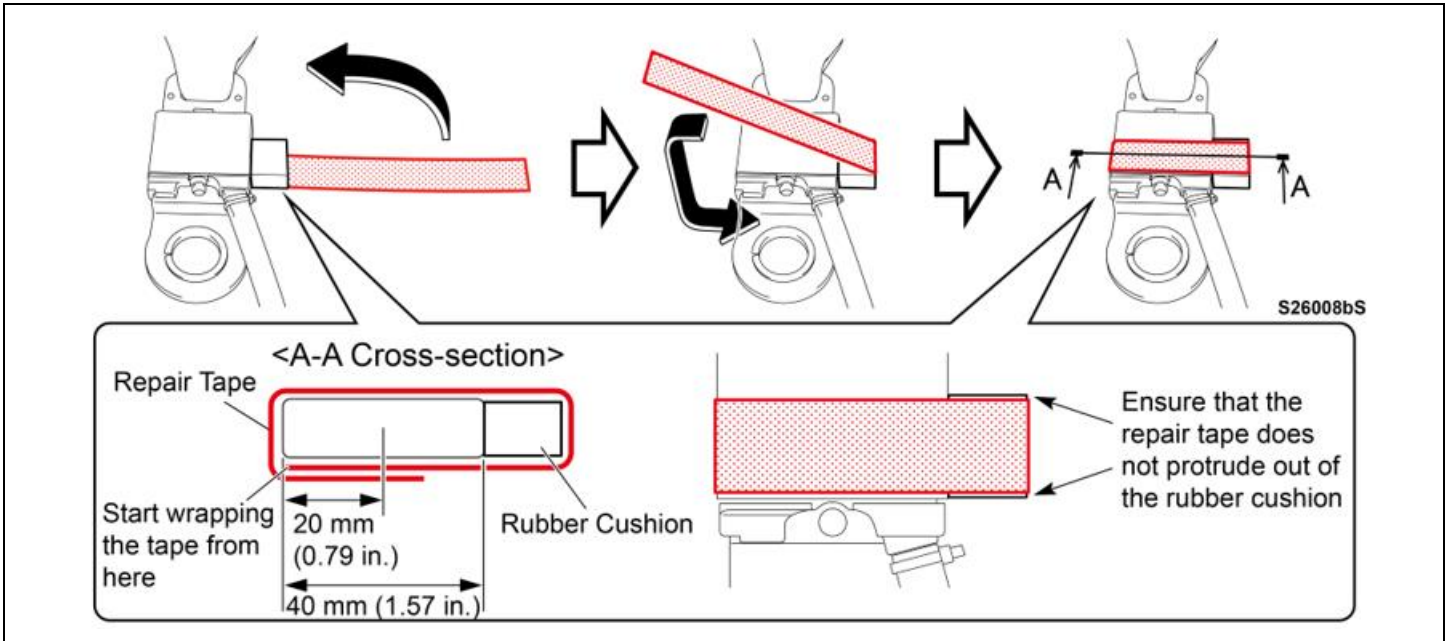

6. REINSTALL SEAT BELT ANCHOR

- a. Install the seat belt anchor with the bolt.

Torque: 42 N·m (428 kgf·cm, 31 ft.lbs)

- b. Connect the electrical connector.

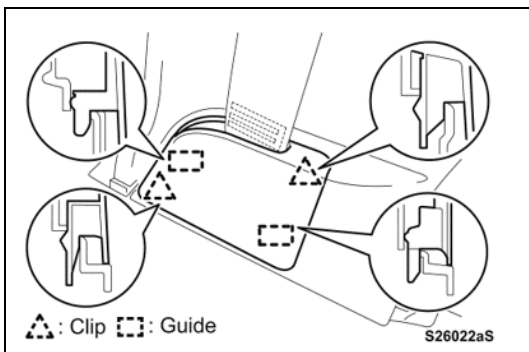

7. REINSTALL CENTER PILLAR GARNISH COVER RH

- a. Push straight down on the cover to engage the 2 guides and 2 clips.

8. ADJUST FRONT RH SEAT POSITION

- a. Return the RH front seat slider to its previous position.
b. Return the RH front seatback to its previous position.



This campaign is now complete. Return the vehicle to the customer.

◀ VERIFY REPAIR QUALITY ▶

- Confirm that the seatbelt retractor operates smoothly.
- Confirm that all interior trim is properly installed.

If you have any questions regarding this update, please contact your regional representative.

10. APPENDIX

A. PARTS DISPOSAL

As required by Federal Regulations, please make sure all recalled parts (original parts) removed from the vehicle are disposed of in a manner in which they will not be reused, ***unless requested for parts recovery return.***

B. CAMPAIGN DESIGNATION DECORDER

