

IMPORTANT UPDATE

**TECHNICAL INSTRUCTIONS
FOR
SAFETY RECALL JLI/JLJ/JLK
FRONT PASSENGER AIRBAG INFLATOR REPLACEMENT
CERTAIN 2006 – 2012 MY IS 250/350 and 2008 – 2009 MY IS F**

Update 02/20/2020

Update 2-20-20

- **Inspection added for ALL repairs. Please see page 13 for details**

The repair quality of covered vehicles is extremely important to Lexus. All dealership technicians performing this recall are required to successfully complete the most current version of the E-Learning course "Safety Recall and Service Campaign Essentials". To ensure that all vehicles have the repair performed correctly:

- **MASTER SERVICE TECHNICIANS**
- **MASTER DIAGNOSTIC SPECIALISTS**

It is the dealership's responsibility to select technicians with the above certification level or greater to perform this recall repair. Carefully review your resources, the technician skill level, and ability before assigning technicians to this repair. It is important to consider technician days off and vacation schedules to ensure there are properly trained technicians available to perform this repair at all times.

NOTE: To support additional service capacity, Lexus Certified and Senior Service Technicians, with at least 36 months Lexus experience AND L652 course credit, may also perform this repair following successful completion of course LSC13B.

I. OPERATION FLOW CHART

The flow chart is for reference only. **DO NOT** use it in place of the full technical instructions. Follow **ALL** steps as outlined in the full technical instructions to confirm the campaign is completed correctly.

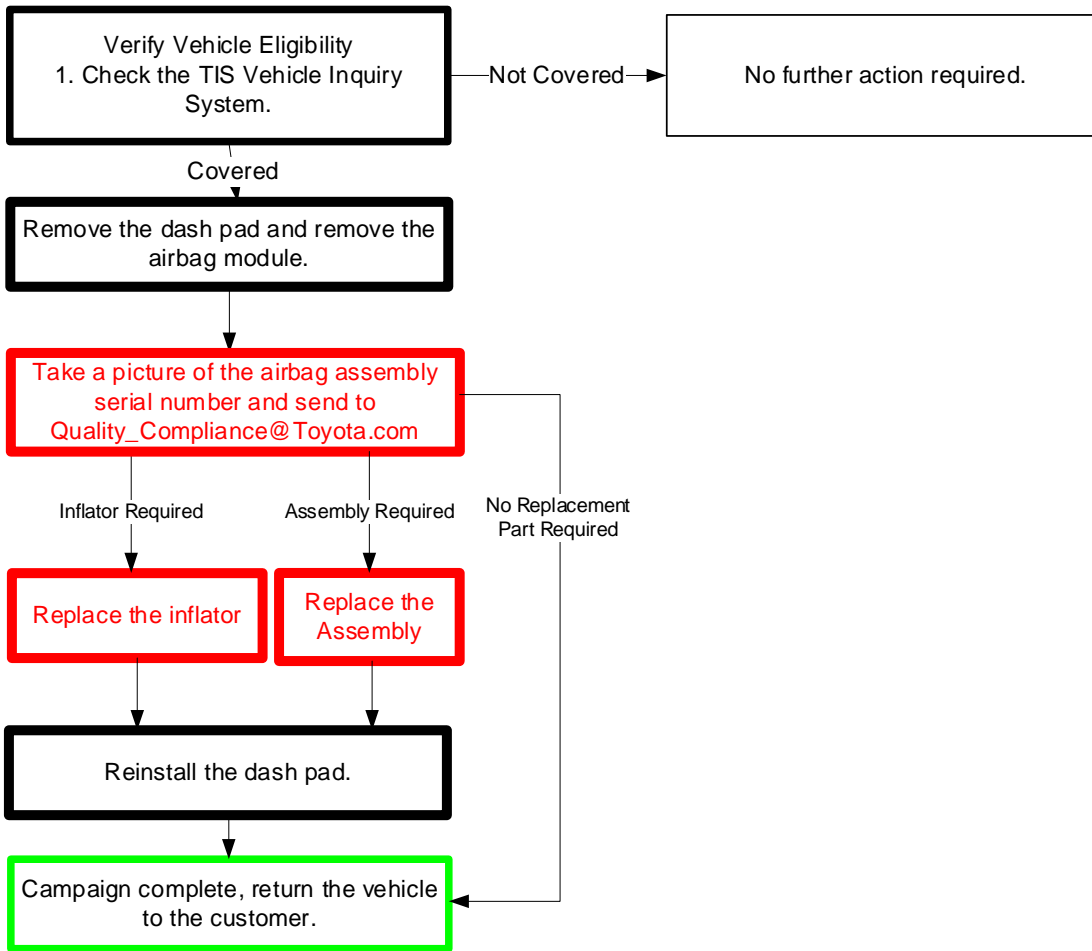

II. BACKGROUND

The subject vehicles are equipped with front passenger airbag inflators produced by Takata. The propellant in these inflators may degrade after prolonged exposure to high absolute humidity and fluctuating high temperatures. Degraded propellant can cause inflator rupture during airbag deployment. In the event of an inflator rupture, metal fragments could pass through the airbag cushion material, striking the vehicle occupants, and result in serious injury or death.

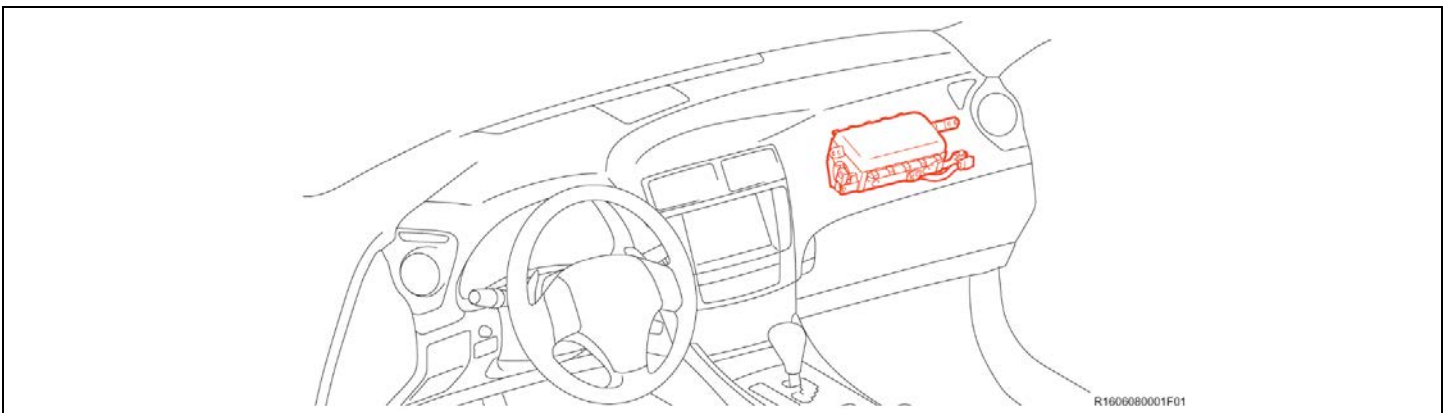

III. IDENTIFICATION OF AFFECTED VEHICLES

A. COVERED VIN RANGE

- Check the TIS Vehicle Inquiry System to confirm the VIN is involved in this Safety Recall, and that the campaign has not already been completed prior to dealer shipment or by another dealer.
- **TMS warranty will not reimburse dealers for repairs conducted on vehicles that are not affected or were completed by another dealer.**

IV. PREPARATION

A. PARTS

Part Number	Part Description	Quantity
04007-06353	Instrument Panel Passenger Airbag Inflator Kit*	1
*The kit above includes the following parts.		
Part Number	Part Description	Quantity
-	Inflator	1
-	Self-locking Nut	5
-	Position Determining Plate	1
04006-66108*	Front Pillar Garnish Kit	1

*The kit contains 2 clips

Non-Desiccated Part Recovery

Dealers should discontinue the installation of the non-desiccated parts listed below for recall, customer pay repairs AND over-the-counter sales (if applicable).

Model	Model Year	Part Number	Part Description
IS 250 – IS 350, IS-F and IS 250C – IS350C	2006-2014	73960-53020 73960-53060	AIR BAG ASSY, INSTR PNL PASS L/DOOR

Lexus requires all dealers to return any parts listed above that still remain in dealer inventory by utilizing the Hazmat Part Return Program available. Dealers will be issued a refund for all part returns. This part return program is outlined in *PANT Bulletin 2014-042*.

Important Note:

In order to return the inflator, packages must **NOT** be opened/tampered with.

B. TOOLS & EQUIPMENT

- Standard hand tools
- Torque wrench
- Techstream
- Molding remover set

GLG/GLH/HLA CAMPAIGN TOOLS – These tools were previously provided to the dealership for campaign DLC and will be used for campaign ELG. These tools are required when performing this repair.

Image	Name	Quantity
	Barcode Scanner	1

NOTE: This tool **CANNOT** be ordered through the parts or tools system. There is a very limited supply of tools, but if additional tools are needed, contact your area representative.

DLC CAMPAIGN TOOLS – These tools are required when performing this repair.

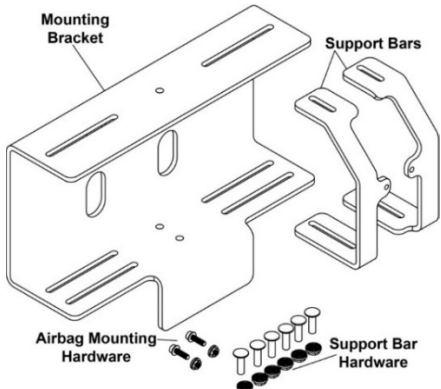
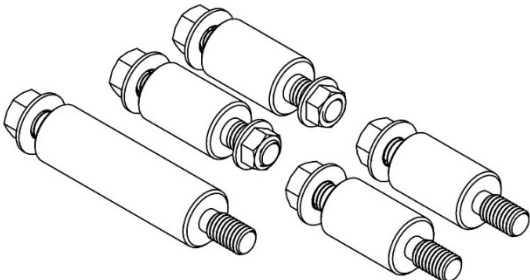
Image	Name	Quantity
	Airbag Mounting Bracket & hardware (Provided to the dealership at the launch of SSC DLC)	1
	579943 Adaptor set*	1

*The adaptor set was sent to dealers prior to the start of this campaign.

SST –These are essential service tools that the dealership should have.

Part Number	Part Name	Quantity
09950-50013	Puller C Set *	1
* The set above includes the following tools.		
Part Number	Part Name	Quantity
09951-05010	Hanger 150	1
09952-05010	Slide Arm	2
09953-05020	Center Bolt 150	1
09954-05021	Claw No. 2	2

V. SAFETY PRECAUTIONS



CRITICAL INFORMATION – READ THOROUGHLY



Failure to follow these procedures correctly could cause the SRS to unexpectedly deploy during servicing or the SRS may fail to operate correctly when required after reassembly. Confirm all work is performed as described in these instructions.

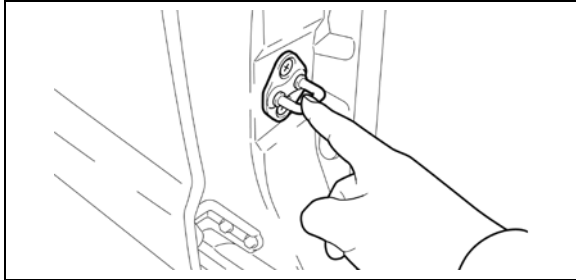

1. ELIMINATE STATIC ELECTRICITY

- a) Before starting work and periodically while working on the vehicle, touch a metallic part of the vehicle to discharge static electricity in the body.



2. DO NOT MEASURE RESISTANCE

- a) **DO NOT** measure resistance of airbag components, this may cause accidental activation.

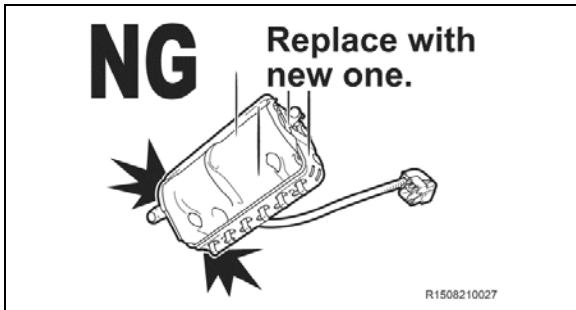

3. HANDLE THE AIRBAG CAREFULLY

- a) If an inflator is dropped, replace it with a **NEW** inflator.

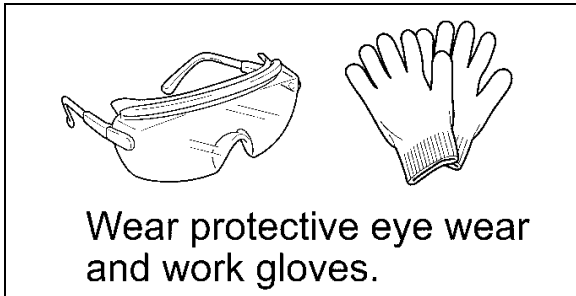

4. WEAR PROTECTIVE EQUIPMENT

- a) Always wear appropriate protective equipment when working on the SRS.

VI. SRS SYSTEM HEALTH CHECK

Confirm the Information and press Next

Required Information:

Division: TOYOTA
Model: < Select >
ModelYear:
Engine:
Option:

Optional Information:

VIN:
Memo:

Manual Help <Back Next> Cancel

1. PERFORM A HEALTH CHECK

- Confirm the Techstream is connected to the dealership's internet.
- When launching the Techstream software the VIN may auto populate if not then it **MUST** be entered manually.

NOTE: All letters of the VIN *MUST* be entered in ALL CAPS, or the VIN will need to be reentered when running the diagnostic report.

- Perform a health check.

2. RUN A DIAGNOSTIC REPORT

- After the health check has completed, run a diagnostic report by clicking on the link on the health check screen.

Monitor Status	DTC	Curr	Pend	Hist	Perm	SB	Calibration	Update

Default User DLC-3

NOTE: If the VIN was not entered in ALL CAPS when Techstream was launched, an error will be displayed and there will be a prompt to reenter the VIN



Diagnostic Report

Vehicle Information

Mileage:

Repair Order:

Report

- Enter the vehicle mileage and repair order information, then click the 'report' button.



- A health check and diagnostic report with the VIN *MUST* be performed within the last 36 hours and recorded by TMS. If the diagnostic report is not run, the healthcheck will not be recognized by TMS.**
- The serial number recording application will be disabled and the inspection cannot be completed if a health check and diagnostic report is not performed and recorded by TMS.**
- This campaign only covers replacement of the passenger dash airbag. If other SRS repairs are needed they are NOT covered under this campaign.**

VII. FRONT PASSENGER AIRBAG REMOVAL COMPONENTS

for Automatic Transmission:

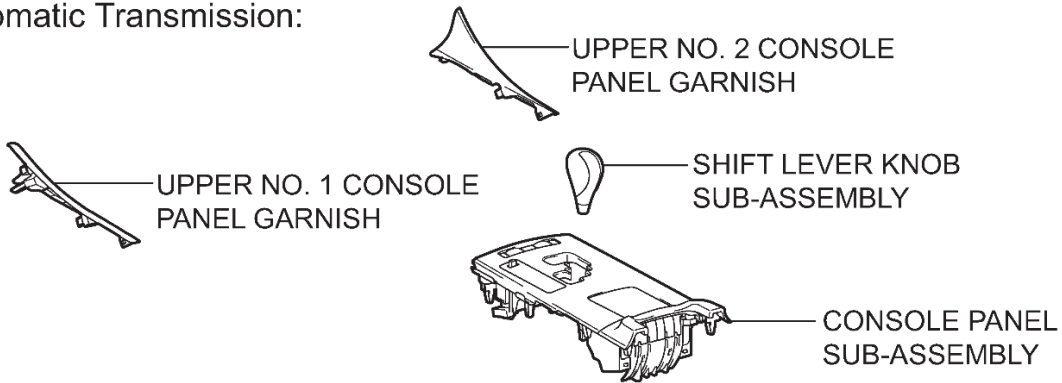

for Manual Transmission:

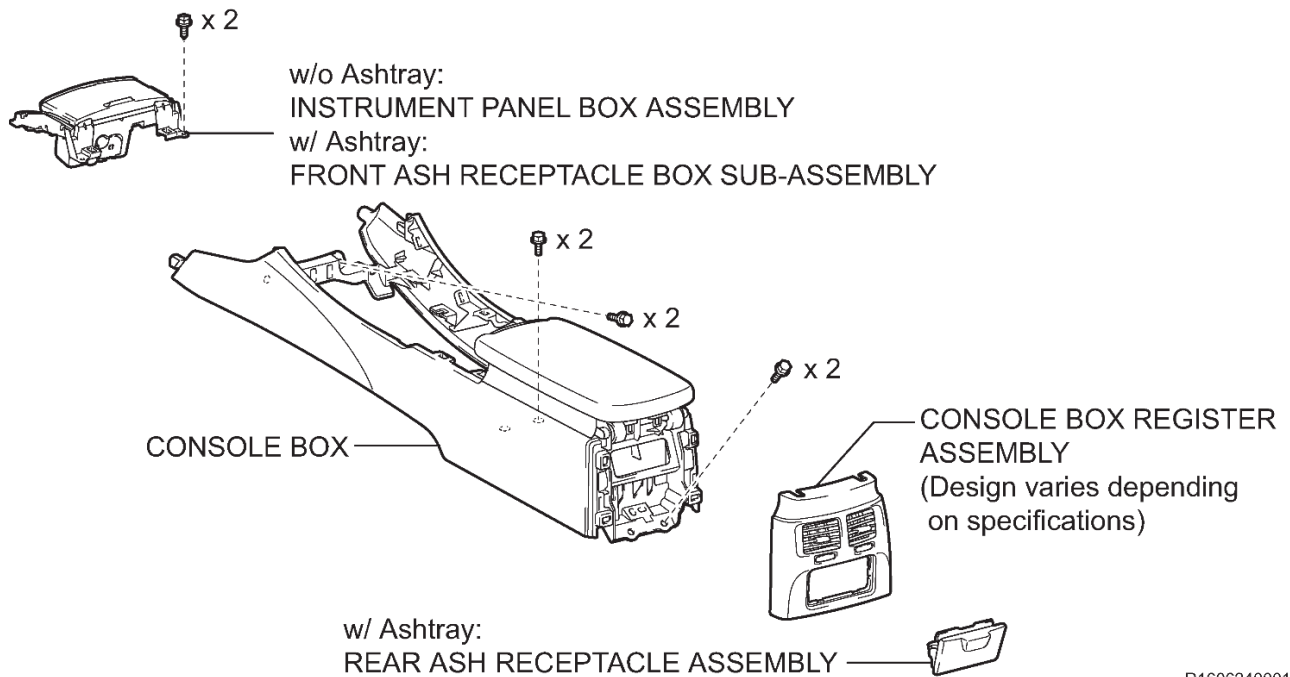
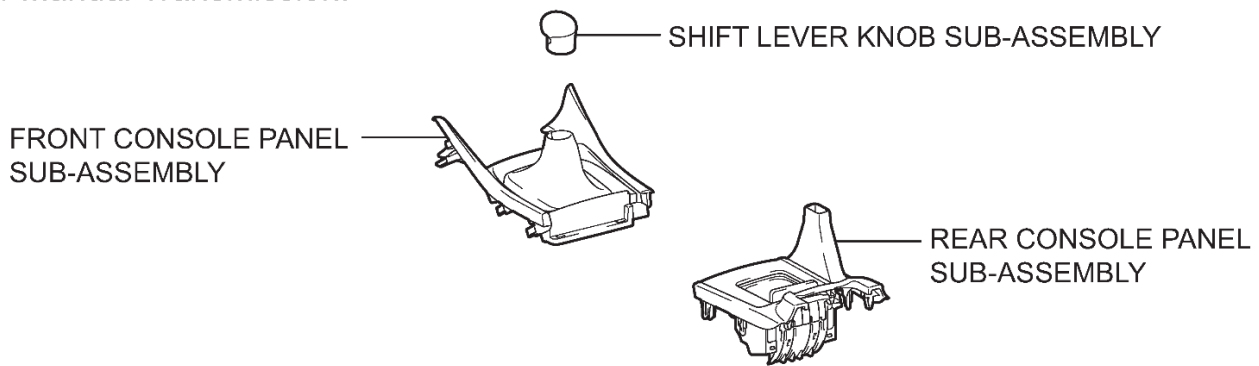

R1606240001

NO. 3 INSTRUMENT PANEL SPEAKER
PANEL SUB-ASSEMBLY

w/ Front Center Speaker:

FRONT STEREO COMPONENT
SPEAKER ASSEMBLY

x 2

● FRONT PILLAR GARNISH CLIP

● FRONT PILLAR GARNISH CLIP

FRONT PILLAR GARNISH LH

FRONT PILLAR
GARNISH RH

INSTRUMENT PANEL CLIP

INSTRUMENT PANEL STAY

INSTRUMENT PANEL
SAFETY PAD ASSEMBLY

NO. 3 INSTRUMENT PANEL
REGISTER ASSEMBLY

x 2

20 (204, 15)

NO. 2 INSTRUMENT
PANEL REGISTER
ASSEMBLY

x 6

NO. 1 INSTRUMENT PANEL
REGISTER ASSEMBLY

x 4

INTEGRATION CONTROL PANEL or
MULTI-DISPLAY or
DISPLAY AND NAVIGATION MODULE DISPLAY
WITH RADIO RECEIVER ASSEMBLY

CENTER LOWER INSTRUMENT
CLUSTER FINISH PANEL

NO. 1 CONSOLE BOX DUCT

for Manual Transmission:

for Automatic Transmission:

NO. 2 CONSOLE BOX DUCT

NO. 2 CONSOLE BOX DUCT

● Replacement part

N*m (kgf*cm, ft*lbf) : Specified torque

R1702150003

1. DISCONNECT THE NEGATIVE BATTERY TERMINAL



- Wait at least 90 seconds after disconnecting the cable from the negative battery terminal to prevent airbag and seat belt pre-tensioner deployment.
- Follow all precautions as outlined on TIS before servicing the SRS system.

2. INSTRUMENT PANEL PRECAUTIONS AND REMOVAL



Prior to dash removal make note of the following precautions. Over time some dash components could be easily damaged if not carefully removed.

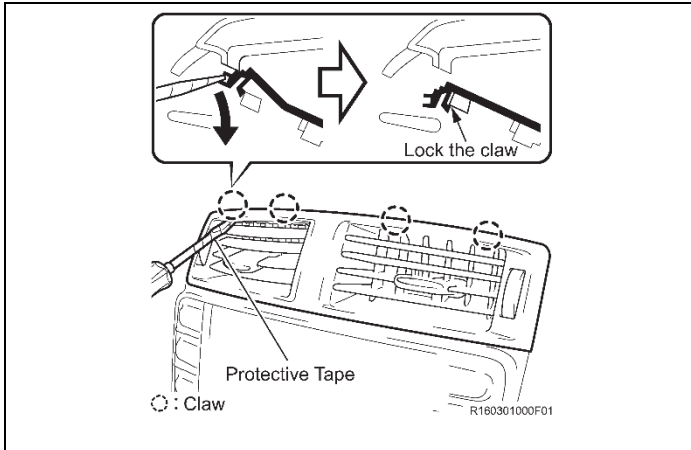

Removing the No. 3 air register

Remove any peripheral parts on left and right side of the register to allow access to the back of the register.

Wrap the tip of a screwdriver with tape.

Lock the 4 claws inside the register as shown.

NOTE: Do not use a molding removal tool to remove the register it could be damaged.

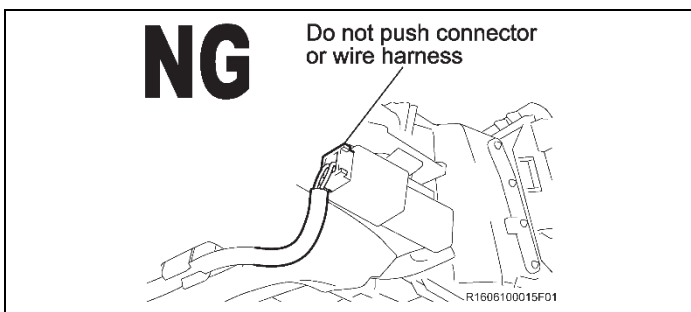
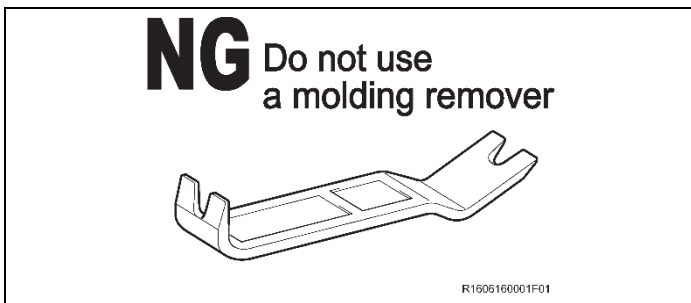

NOTE: When removing the register DO NOT push on the connector or wiring as it could be damaged.

You will remove the register by pushing from the back.

【Example for removal of center register】

OK Push from the back side

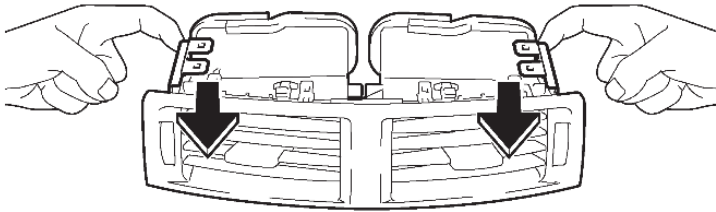

NG Pry from the front side

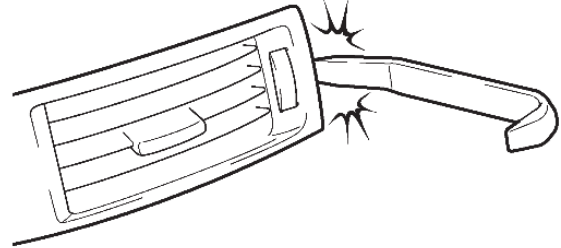

R1606130005F01

Using your finger on the left side push out at the point shown to disengage the 4 claws.

Back side of part manufactured before August 2008:

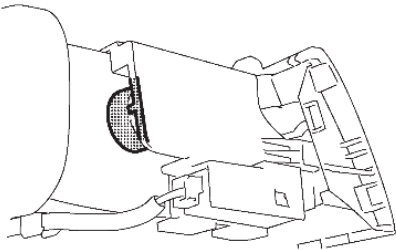

Back side of the part manufactured after August 2008:

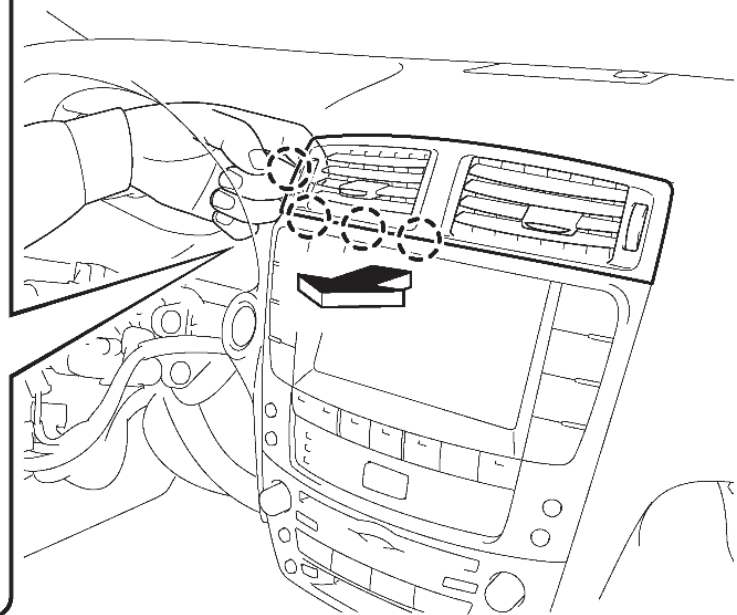
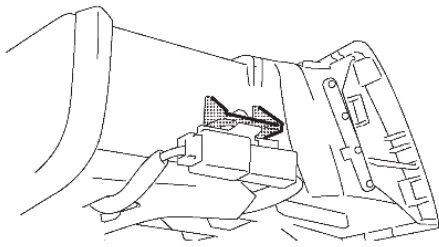

○ : Claw

R1606100013F01

Using your finger on the right side push out at the point shown to disengage the 3 claws and remove the register from the instrument panel.

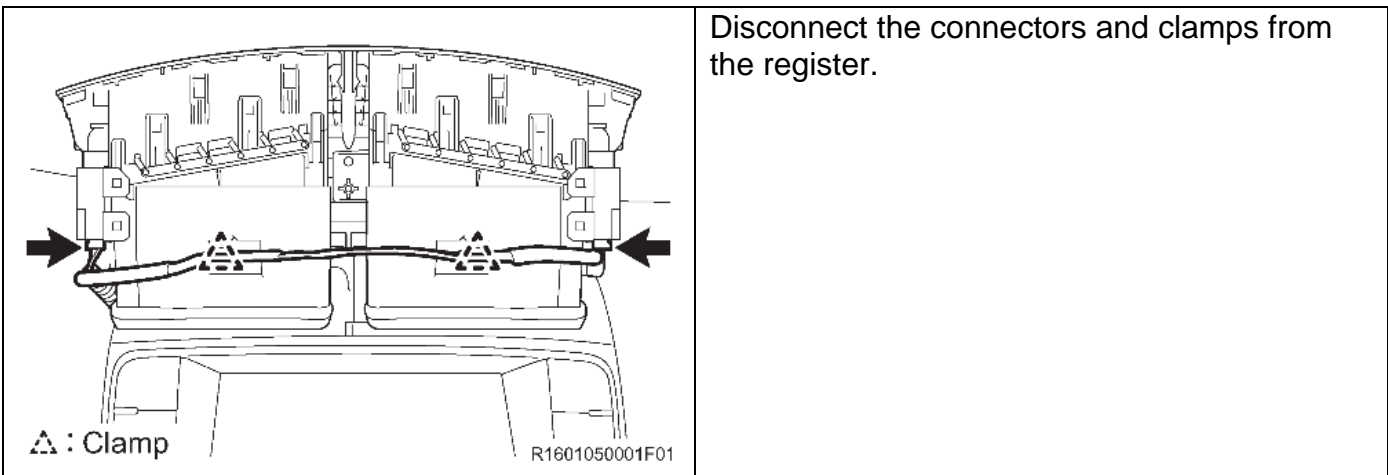
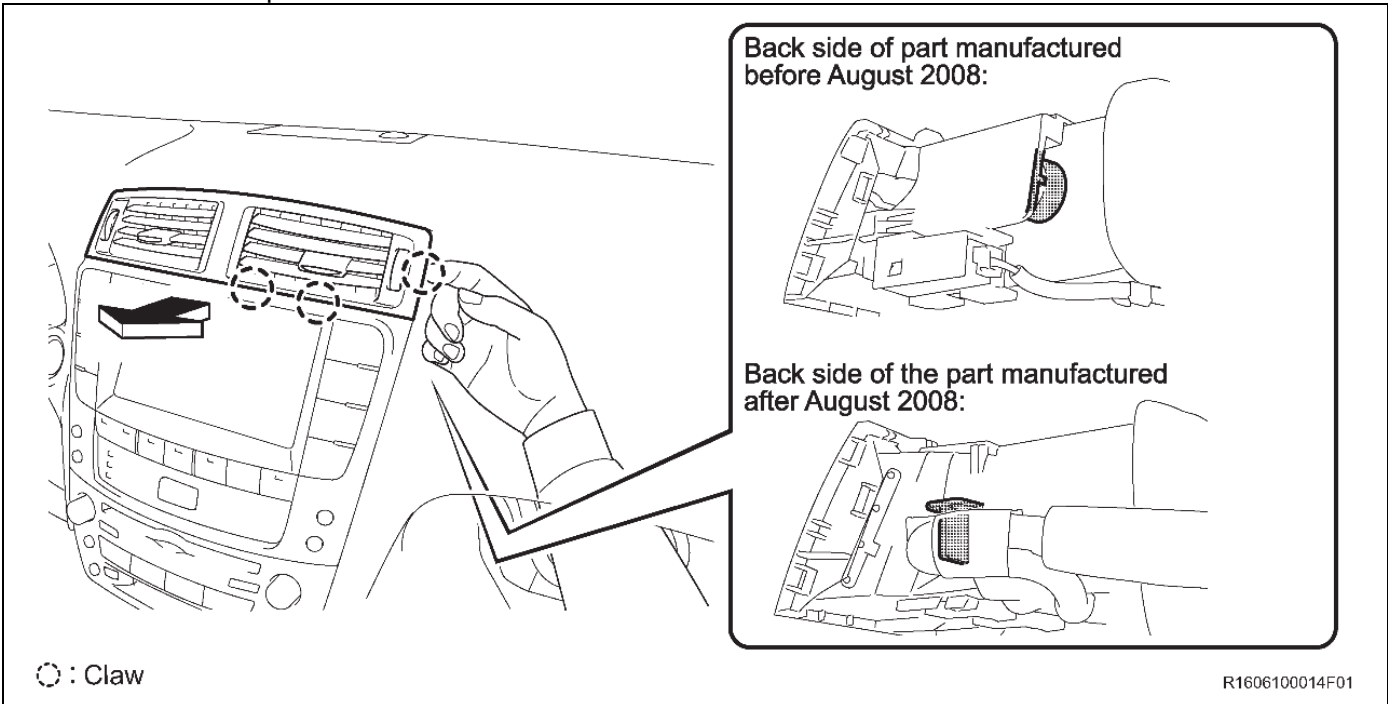

NOTE: DO NOT contact the positioning tabs while removing the instrument panel as the panel could be damaged.

a) Refer to TIS for removal instructions

IS 250/350	2006 MY	2007 MY	2008 MY	2009 MY	2010 MY	2011 MY	2012 MY
IS F	2008 MY	2009 MY					

3. REMOVE THE AIRBAG FROM THE DASH

- a) Remove the 3 screws and the side defroster nozzle.
- b) Remove the 2 screws and the heater to register duct.

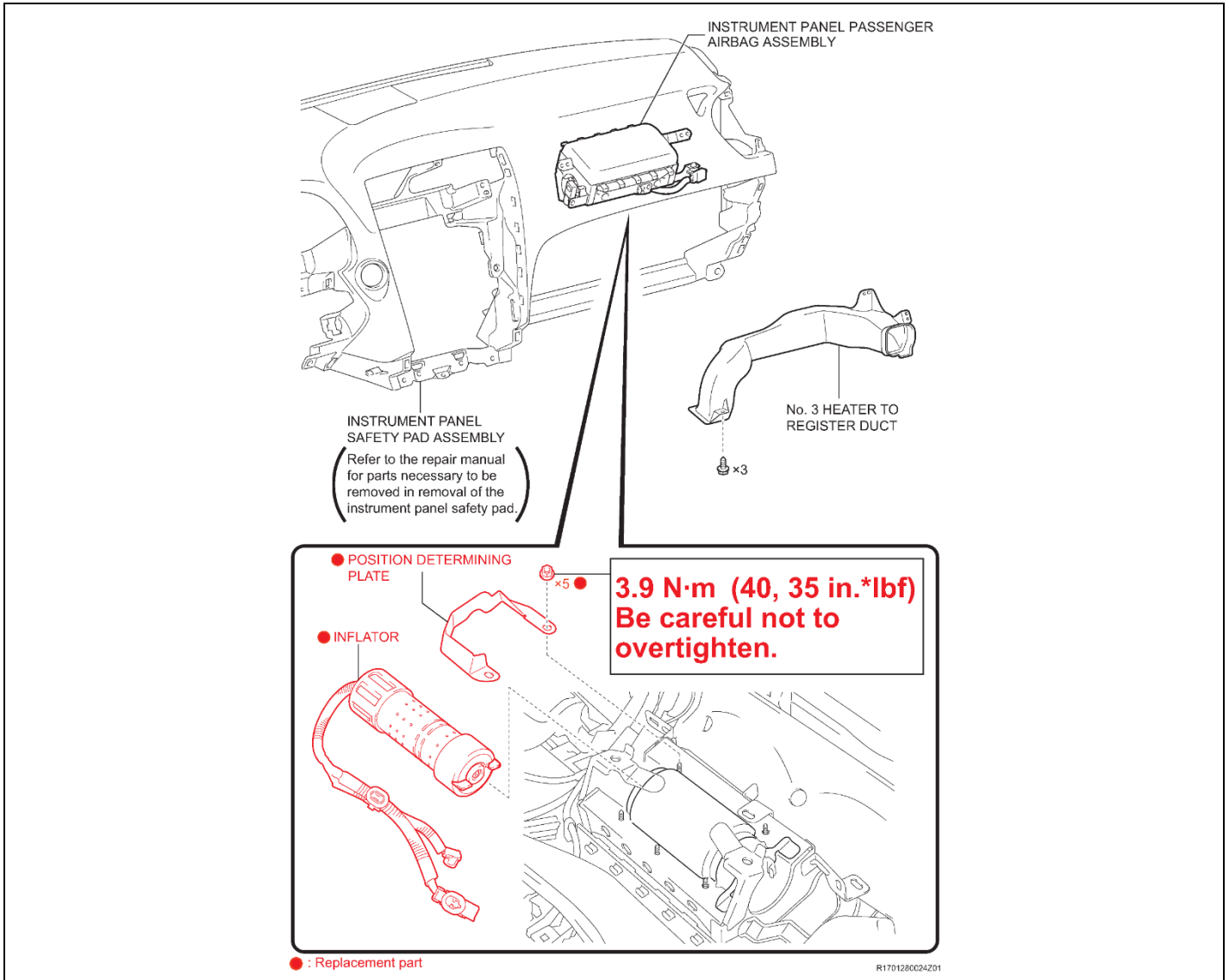

- c) Remove the 4 bolts, disengage the straps, and then remove the airbag assembly.

NOTE: Use a screwdriver with the tip wrapped in tape to remove the airbag from the dash.

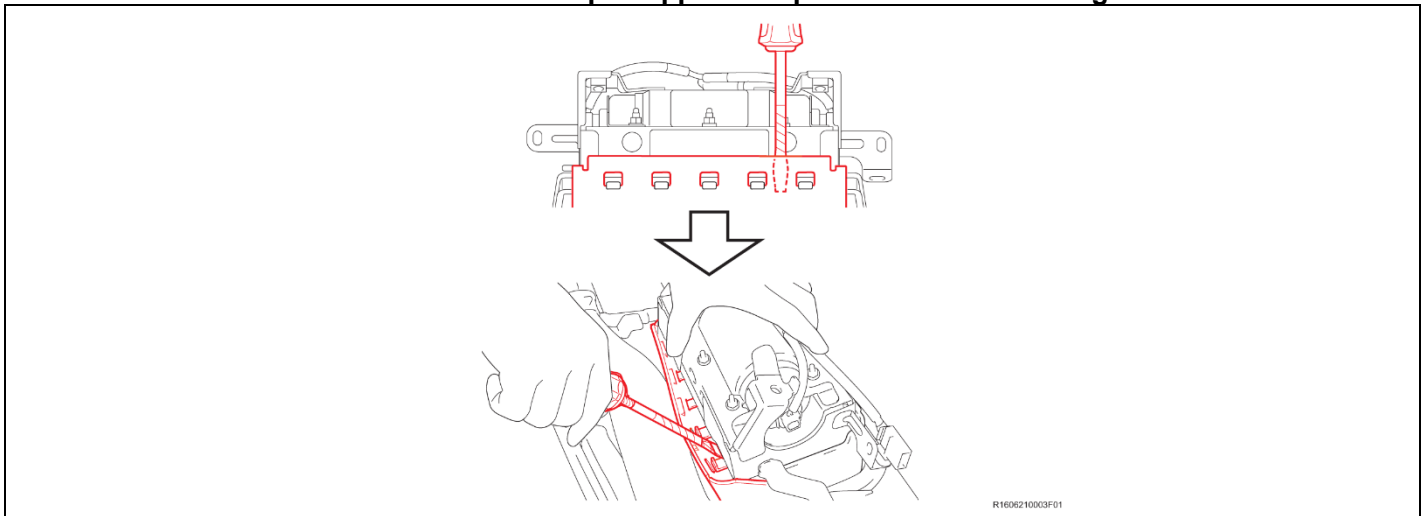

4. INSPECT AIRBAG ASSEMBLY

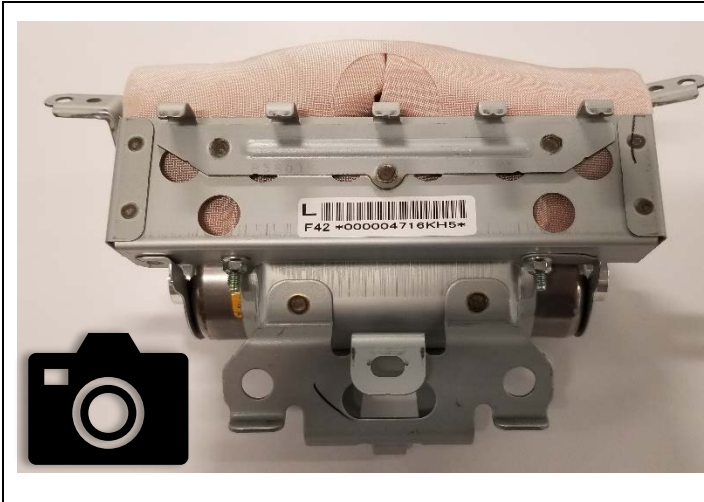

1. TAKE A PICTURE OF THE AIRBAG ASSEMBLY SERIAL NUMBER

- a) Take a picture of the airbag assembly serial number exactly like the image to the left.
- b) Email the picture to Quality_Compliance@toyota.com for review.

Email Format

Subject: JLI/JLJ/JLK Airbag Serial Number Review

Body: (Insert Model/Model Year of vehicle)

- c) You will receive a reply with instructions on how to proceed with the repair.

5. REMOVE THE INFLATOR (Only required if instructed by Quality Compliance)

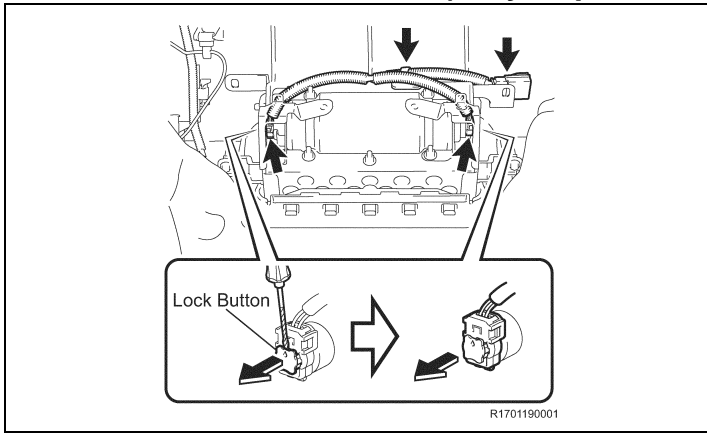

- a) Using a screwdriver to release the lock button of the connector.
- b) Disconnect the 2 connectors.
- c) Disengage the 2 clamps.

NOTE: The removed instrument panel wire will not be reused.

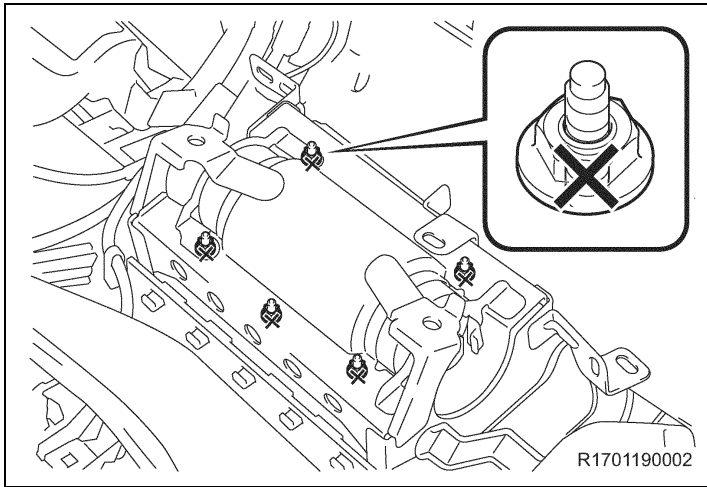

- d) Mark the 5 self locking nuts to prevent reuse.



e) Mount the adaptors (579943-3R3) to the airbag as shown.

NOTE: The 6mm stud mounts to the airbag.



f) Mount the airbag to the mounting bracket as shown.

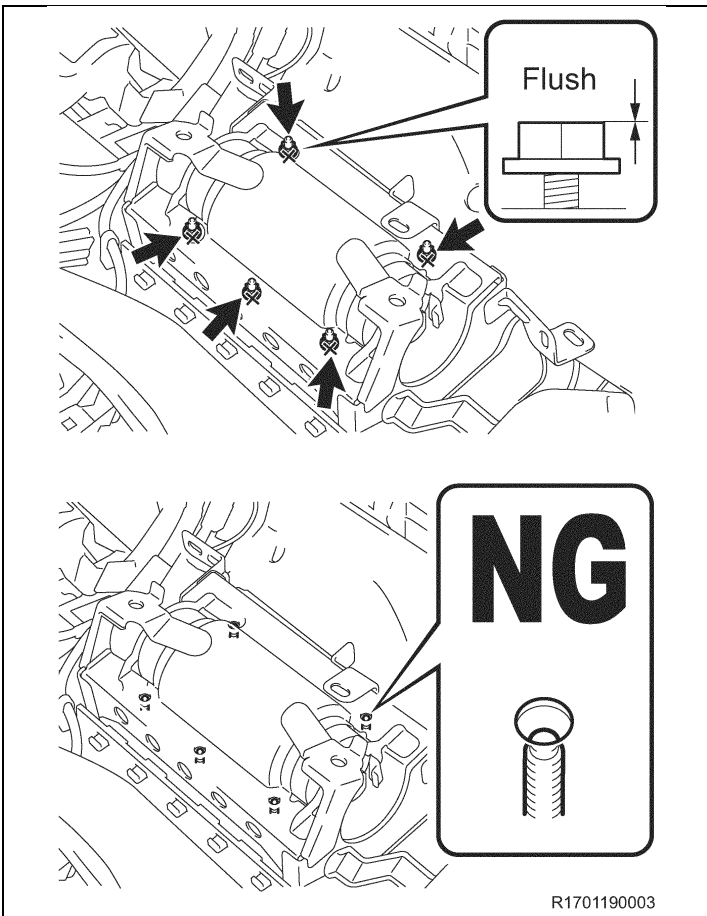

g) Loosen the 5 nuts until each nut is flush with the top of the stud as shown.

NOTE: You may need to slide the airbag to the left or right to access the middle nut. DO NOT use power tools to remove the nuts.

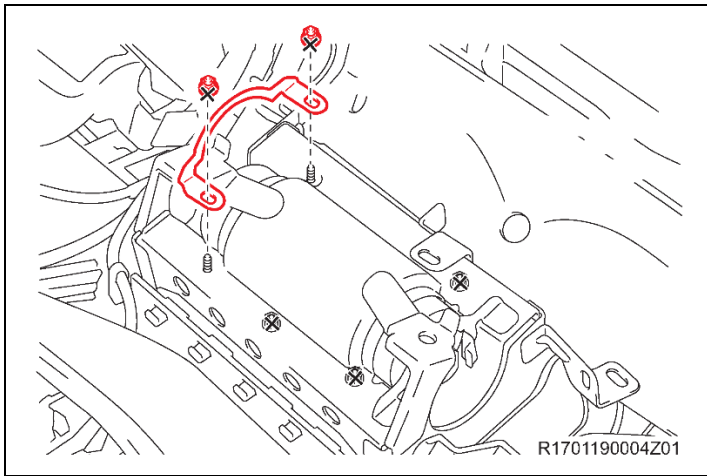

- h) Loosen and discard the 2 nuts on the end where the positioning plate is removeable.
- i) Remove and discard the plate.

NOTE:

DO NOT use power tools.

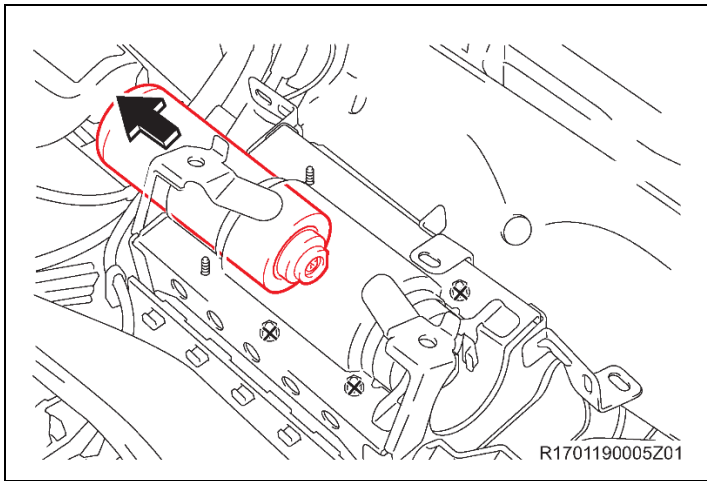

- j) Remove the inflator.

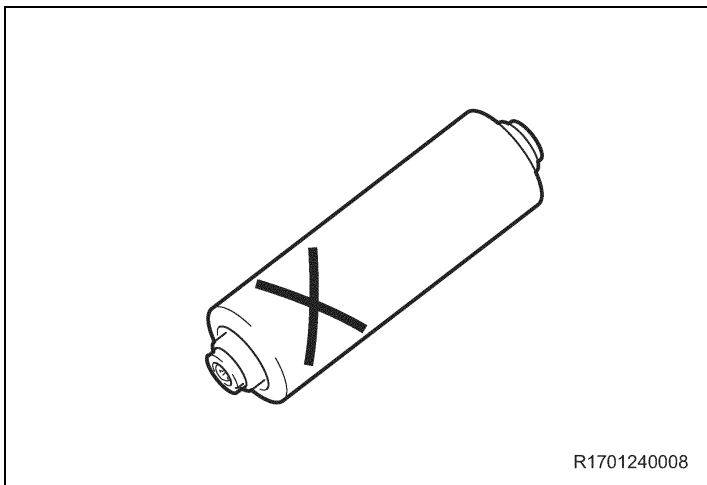

- k) Mark the old inflator so it is not reused.
- NOTE: Return the old inflator to the parts department for recovery.**

VIII. AIRBAG RECORDING

1. LAUNCH THE SERIAL NUMBER RECORDING APPLICATION

Note: The Serial Number Recording Application is the same application used for DLC.



- The AIRBAG ASSEMBLY serial numbers **MUST** be recorded using a barcode scanner (provided at the launch of SSC DLC).
- The barcode scanner application **MUST** be completed on every vehicle. These numbers **MUST** be included on every warranty claim that is submitted for airbag module replacement or the claim may be subject to debit.
- The technician performing the work **MUST** have valid TIS login credentials and an internet connection to perform the inspection and scanning process.

- Log in to TIS and input the VIN of the vehicle in the Vehicle Inquiry tab.
- Confirm the VIN is applicable and that the campaign has not been completed.
- Click on the link to launch the serial number recording application.

The screenshot shows the Toyota TIS Vehicle Inquiry application. The VIN search field contains 'VIN: INX BR32E 000000000' with a red circle around it labeled 'a)'. Below, the Vehicle Information section shows details for a 2003 Toyota Corolla. The Service Campaign section shows a 'Safety Recall D0F Remedy Notice' with a completion status of 'Not Completed' and a link to 'Check applicability for VIN' circled in red and labeled 'b)'. A red circle labeled 'c)' is also present around the 'Check applicability for VIN' link.

- Reenter TIS password in the serial number recording application.

NOTE: The person logged-in to TIS MUST be the person performing the repair.

The screenshot shows the 'Front Passenger Airbag Inflator Module - Safety Recall SSC - DSF' application. It displays user information, technician name (Russell Suzuki), and a 'Mileage*' field circled in red. Below is a table with columns for Task, Dealer, User, Time, and Status.

Task	Dealer	User	Time	Status
Inflator # Record				Not Started
Inflator # Record				Not Started
Terms & Conditions				Not Started
New Airbag #				Not Started

- Record the vehicle mileage into the serial number recording application.

NOTE:

- A task status screen will populate next and at other intervals during the repair. This screen will indicate if the inflator was replaced or in some limited cases that the entire airbag assembly was replaced. Click 'next' to proceed to the next step. This information will be used for record keeping by TMS.
- If this screen indicates that the campaign has already been completed on this VIN, there is no need to perform the campaign again.

2. CONNECT THE BARCODE SCANNER

- Connect the barcode scanner to the USB port on the Techstream.
- The scanner will automatically connect and a beep will be heard when the scanner is ready.

NOTE:

- The scanner was provided for SSC DLC.
- The barcode scanner works best in low light conditions.
- Always hold the scanner directly in front of and parallel to the barcode label.

3. SCAN THE AIRBAG SERIAL NUMBER

ATTENTION: This information is **CRITICAL**

- Scan the **AIRBAG ASSEMBLY** serial number 2 times.
 - Confirm the cursor is in the first serial number box then scan the serial.
 - Position the cursor in the second serial number box then scan the serial.
- Click next.

NOTE:

- If both serial numbers that are entered do not match, confirm and reenter.
- If the serial number barcode will not scan, it can be entered manually.

AIRBAG SERIAL NUMBER IDENTIFICATION

- The airbag serial number is **ALWAYS** the 12 **DIGITS** located between the asterisks.
- The 3 digits before the asterisk **ARE NOT** part of the serial number, and **SHOULD NOT** be entered or an inaccurate response may be returned.

Airbag Serial Number Label Example



The **AIRBAG ASSEMBLY** serial number **MUST** be recorded prior to replacement.

Front Passenger Airbag Inflator Module - Safety Recall

SSC DSC

1 2 3 4 5

User ID: _____ Technician Name: _____

Dealer Code: _____ Dealer Name: _____

Time: 03/30/2015 05:15 AM PDT VIN: 1NX BR32E 14Z308698 [2004 Corolla SUPER WHITE]

Original Airbag Module - 12 Digits
Between the asterisk (*) symbols

Record Airbag Serial Number

How to Identify an Airbag module Assembly number?

The Airbag module Assembly serial number is a 12 digit code. It can be found along with a bar code on opening the Airbag assembly unit. To manually enter these details into the application, the technician has to identify the 12 digit code between two Asterisks (*) inside the Airbag assembly unit. The first seven characters of this 12 digit code are numbers and the 10th digit is either 'K' or 'L' always.

Use of a barcode scanner is strongly recommended when entering Airbag Assembly Serial Number.

If manually typing serial number, you MUST include all leading zeros. (If applicable)

*Airbag Assembly Serial Number:

*Reconfirm Airbag Assembly Serial Number:

If original Airbag Assembly serial number is not visible or missing, check this box

Clear Next

(*) - Indicates Required Field(s)

Front Passenger Airbag Inflator Module - Safety Recall

SSC - E04

1 2 3 4 5

User ID:

Dealer Code:

Time: 03/30/2015 05:17 AM PDT

VIN: 1NX BR32E 14Z308698 [2004 Corolla SUPER WHITE]

Technician Name:

Dealer Name:

Airbag Serial #: *****12

Original Inflator

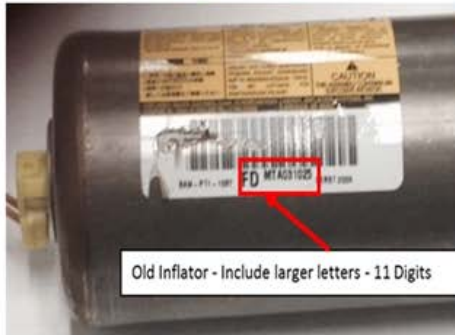

How to Identify the Inflator serial code on the Original and Replacement Inflator can?

The Inflator serial code is an 11 digit code on the Inflator can. It can be found with a bar code on removing the Inflator can from the Airbag Assembly unit.

The first two characters of the Original Inflator Serial code will be from [AA, AB, AJ, FD or JD].

The first two characters of the Replacement Inflator Serial code will be either 'LT' or 'LR'.

Replacement Inflator



Inflator Module replacement IS REQUIRED on all vehicles under the Safety Recall. Follow the technical instructions and acknowledge the following statements.

If manually typing serial number, you MUST include all leading zeros. (If applicable)

Original Inflator Serial #:

If old inflator serial number is not visible or missing, check this box.

* Replacement Inflator Serial #:

If you have a concern with the inflator serial numbers, please email quality_compliance@toyota.com with details.

- I agree to complete the safety recall's remaining technical instructions.
- I agree to perform a vehicle Health Check with Techstream upon completion of the safety recall's technical instructions.

(*) - Indicates Required Field(s)

Back Clear

c) Confirm agreement by checking the two boxes and press submit.

d) Record the Warranty Authorization # to be included in the warranty claim.

Front Passenger Airbag Inflator Module - Safety Recall
SSC - DSF

1 2 3 4 5

User ID: SuzukiR **Technician Name:** Russell Suzuki
Dealer Code: **Dealer Name:**
Time: 06/10/2014 05:13 PM PDT **Airbag Serial #:** *****96
Original Inflator Serial #: AAEL5110212 **Replacement Inflator Serial #:** AAEL5110213

SuzukiR has agreed to the following terms and conditions on 06/10/2014 05:13 PM PDT

* I agree to complete the safety recall's remaining technical instructions.
 * I agree to perform a vehicle Health Check with Techstream upon completion of the safety recall's technical instructions.

Russell Suzuki has successfully confirmed completion of Airbag Inflator Module Safety Recall for
VIN - 5TD BT44A 33S157291 [2003 Sequoia BEIGE M. M.]
Warranty Authorization #: b5511e9f
Airbag inflator module was replaced under this safety recall.
Print this page for your records and then click 'Close' to resume working.

Close

e) Confirm agreement by checking the two boxes.

f) Place the old airbag in the parts box and return it to the parts department.

NOTE:

- **Keep all shipping paperwork with the box that it came in.**
- **Confirm the cursor is in the correct serial number input box before scanning.**
- **If the serial number barcode will not scan, it can be entered manually.**
- **If there are any difficulties or concerns with this process, email quality_compliance@toyota.com with details.**

NEW AIRBAG ASSEMBLY RECORDING



If the airbag serial number and barcode are not legible or are not present, check the box in the application indicating the serial number is not legible.

a) If the airbag serial number cannot be scanned or is not present check the box as shown below.

Front Passenger Airbag Inflator Module - Safety Recall
SSC DSC

1 2 3 4 5

User ID: _____ Technician Name: _____
Dealer Code: _____ Dealer Name: _____
Time: 03/30/2015 05:15 AM PDT VIN: 1NX BR32E 14Z308698 [2004 Corolla SUPER WHITE]



Record Airbag Serial Number

[How to Identify an Airbag module Assembly number?](#)

The Airbag module Assembly serial number is a **12 digit code**. It can be found along with a bar code on opening the Airbag assembly unit. To manually enter these details into the application, the technician has to identify the 12 digit code between two Asterisks (*) inside the Airbag assembly unit. The first seven characters of this 12 digit code are numbers and the 10th digit is either 'K' or 'L' always.

Use of a barcode scanner is strongly recommended when entering Airbag Assembly Serial Number.
If manually typing serial number, you **MUST** include all leading zeros. (If applicable)

* Airbag Assembly Serial Number:
* Reconfirm Airbag Assembly Serial Number:

If original Airbag Assembly serial number is not visible or missing, check this box

(*) - Indicates Required Field(s)

Check this box if the Airbag serial number is not legible.

**Note: Contact your area office in the event you are unable to read the serial number
DO NOT ATTEMPT TO INSTALL THE INFLATOR**

- a) After the Area office approves the Airbag replacement and the new part is received, scan the new Airbag barcode in the Serial Number Recording Application.

Front Passenger Airbag Inflator Module - Safety Recall

SSC DSC

1 2 3 4 5

User ID: _____ Technician Name: _____
Dealer Code: _____ Dealer Name: _____
Time: 03/30/2015 05:15 AM PDT VIN: 1NX BR32E 14Z308698 [2004 Corolla SUPER WHITE]



Record Airbag Serial Number

[How to Identify an Airbag module Assembly number?](#)

The Airbag module Assembly serial number is a **12 digit code**. It can be found along with a bar code on opening the Airbag assembly unit. To manually enter these details into the application, the technician has to identify the 12 digit code between two Asterisks (*) inside the Airbag assembly unit. The first seven characters of this 12 digit code are numbers and the 10th digit is either 'K' or 'L' always.

Use of a barcode scanner is strongly recommended when entering Airbag Assembly Serial Number.

If manually typing serial number, you MUST include all leading zeros. (If applicable)

*New Airbag Assembly Serial Number:

I agree to complete the safety recall's remaining technical instructions.

I agree to perform a vehicle Health Check with Techstream upon completion of the safety recall's technical instructions.

(*) - Indicates Required Field(s)

Next

- b) Confirm agreement by checking the two boxes and press next to advance to the Warranty authorization screen.
- c) Return the old airbag to the parts department.
- d) Proceed to Section IX Step 2.



The new **AIRBAG ASSEMBLY** serial number **MUST** be recorded prior to reinstallation to track the airbag assembly to the vehicle.

IX. AIRBAG INFLATOR INSTALLATION (Only required if instructed by Quality Compliance)

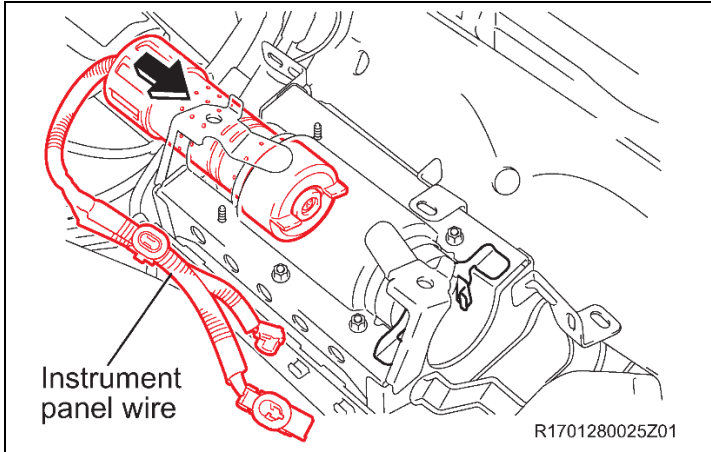

1. **INSTALL THE NEW INFLATOR**
 - a) Install the new inflator as shown.

b) Ensure that the inflator is oriented in the correct position as shown.



- **Make sure the inflator is correctly positioned.**
- **The inflator cannot be fully inserted if it is upside down.**

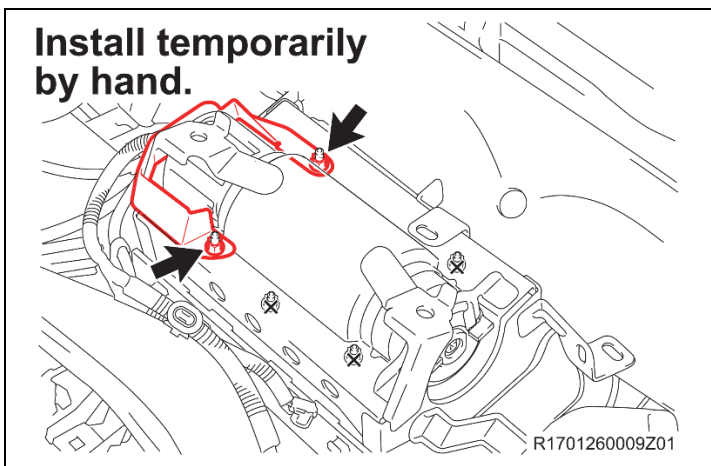
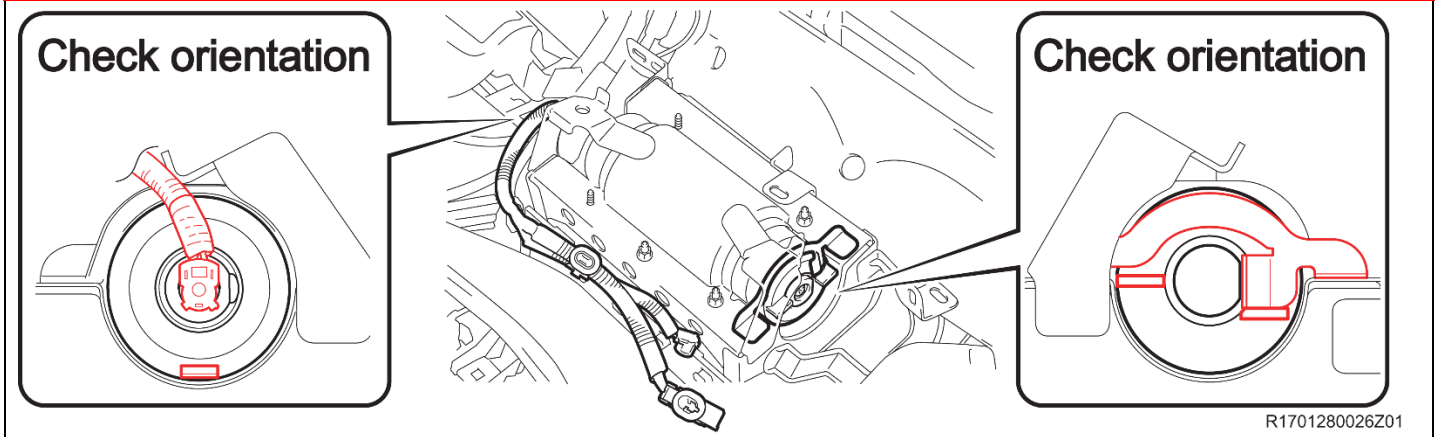

- e) Install the **NEW** positioner plate.
- f) Temporarily install 2 **NEW** nuts.

**Install temporarily
by hand.**

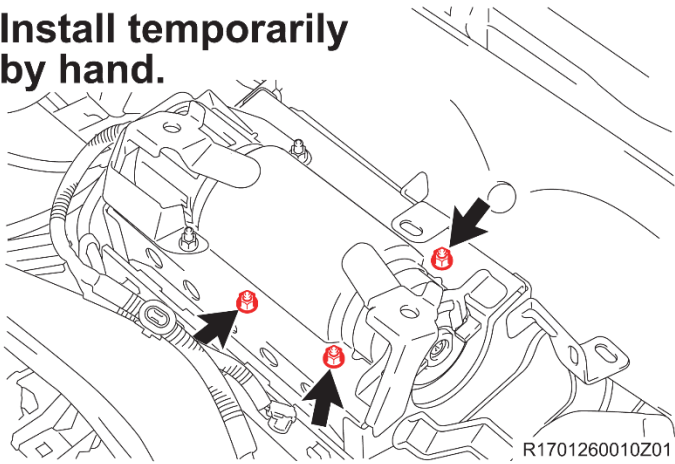

- g) Remove and discard the 3 remaining nuts.
- h) Temporarily install 3 **NEW** nuts.

- i) Push the inflator towards the position determining plate and eliminate any gaps.



- If any gaps exist, the flats may move apart and could result in abnormal operation during airbag deployment.

**(a) Replacement
of parts.**

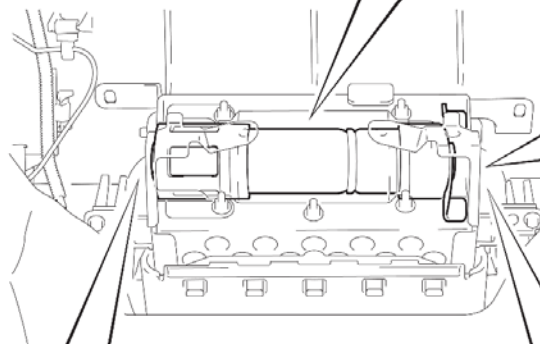
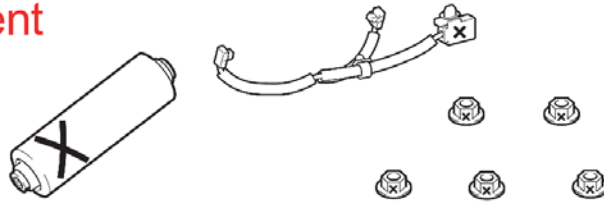

(b) No gap.

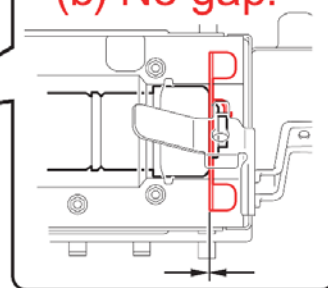

(b) Check orientation.

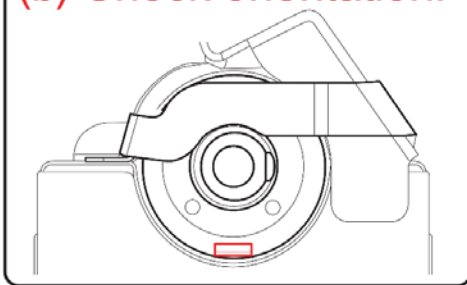

(b) Check orientation.

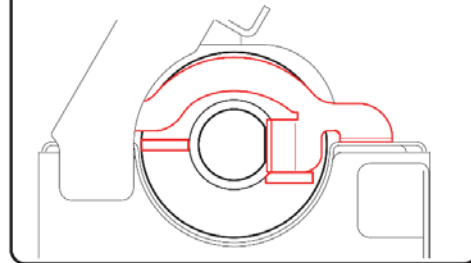

R1701260003Z01

j) Tighten the 5 nuts evenly in several increments in the sequence shown. Use a socket driver or torque wrench to tighten the nuts.

Torque: 35 in. lbf (3.9N·m)



- There will be some resistance when tightening the nuts because they are self-locking, confirm the nuts are tightened correctly.
- **DO NOT** use a power tool, T-handle, or ratchet when tightening the nuts to avoid over torquing and deforming the studs.
- You may need to slide the airbag to the left or right with in the mounting bracket to access the center nut.

OK

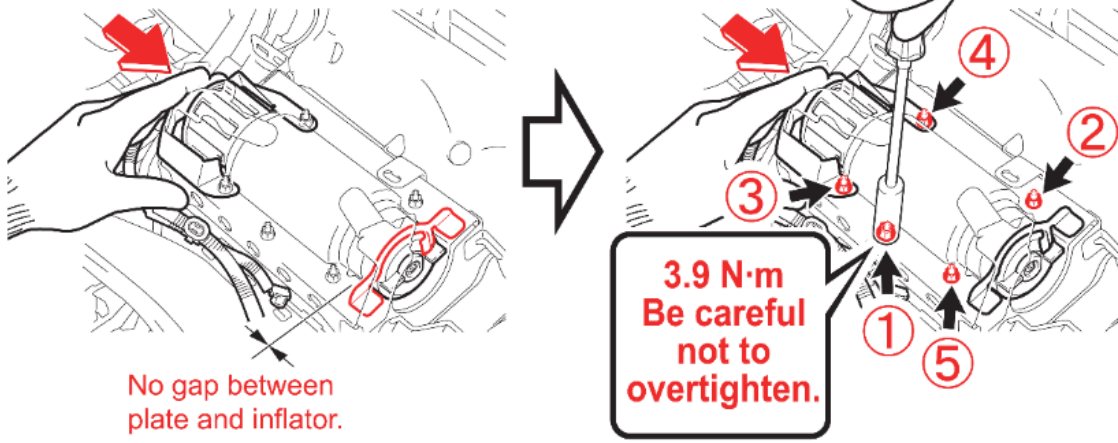

NG

NG

NG



These tools cause overtightening !

R1701260011Z01

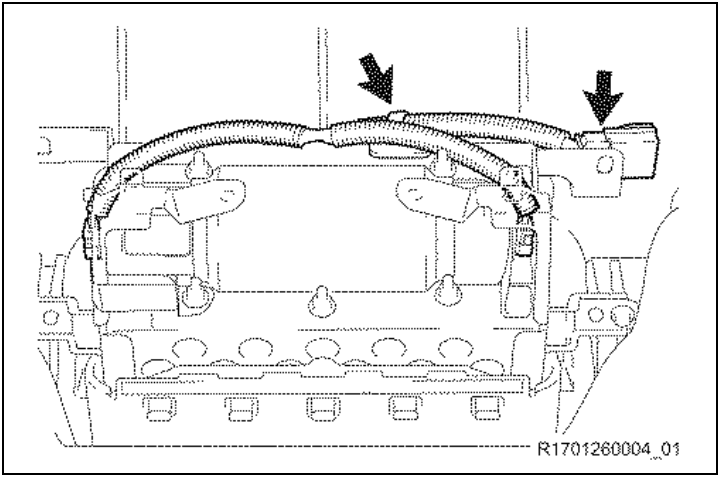

k) Engage the 2 clamps for the new wire harness.

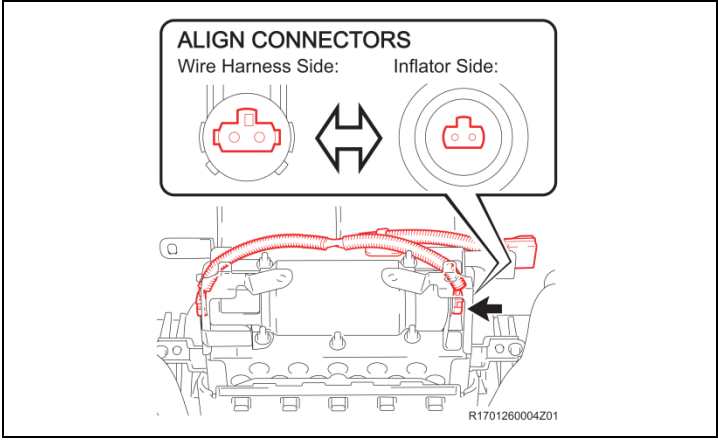

l) Connect the connector and the secondary lock.

NOTE: Ensure that the connector is securely connected.

X. AIRBAG ASSMEBLY INSTALLATION

1. REINSTALL THE AIRBAG ASSEMBLY INTO THE INSTRUMENT PANEL

- a) Position the airbag assembly in the instrument panel, engage the straps, and then install the 4 bolts.



- The bolts do NOT need to be replaced. Reinstall the original bolts

NOTE: Ensure the airbag connectors is positioned as shown

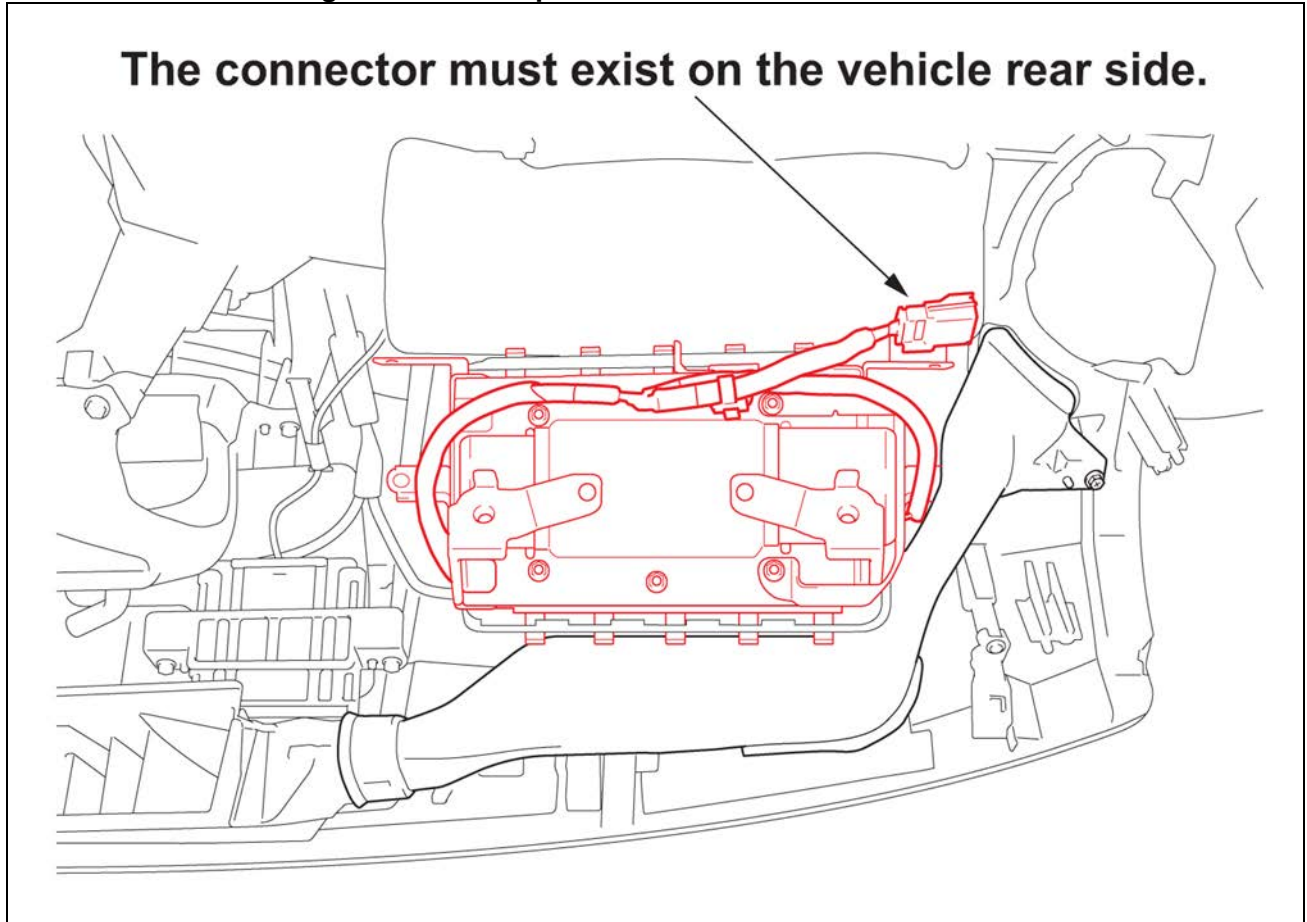

- b) Install the 2 screws and the heater to register duct.
- c) Install the 3 screws and the side defroster nozzle.

3. REINSTALL THE DASH

a) Refer to TIS for reinstallation instructions

IS 250/350	2006 MY	2007 MY	2008 MY	2009 MY	2010 MY	2011 MY	2012 MY
IS F	2008 MY	2009 MY					

4. RECONNECT THE NEGATIVE BATTERY CABLE
5. PERFORM A HEALTH CHECK AND DIAGNOSTIC REPORT
6. PERFORM ANY NEEDED SYSTEM INITIALIZATIONS

◀ VERIFY REPAIR QUALITY ▶

- Confirm all precautions are followed to ensure safety during the repair
- Confirm the entire serial number checker application is completed and the warranty authorization # is recorded on *EVERY* vehicle
- Confirm the old airbag is handled safely and given to the appropriate parts professional for shipment

If you have any questions regarding this update, please contact your area representative.

XI. APPENDIX

A. CAMPAIGN DESIGNATION DECODER

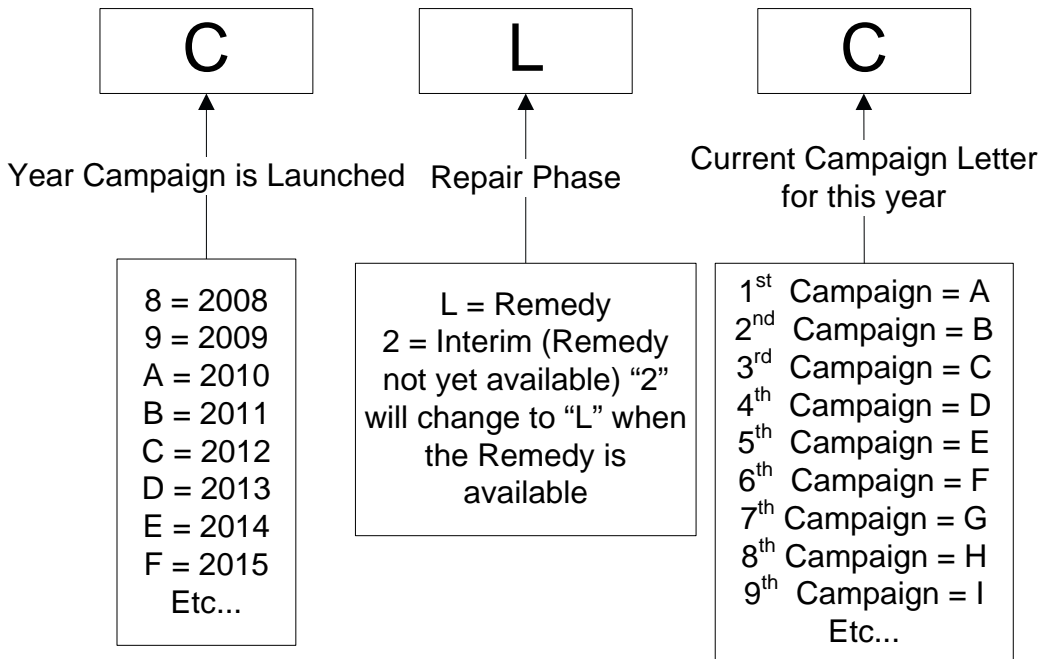

B. CAMPAIGN PARTS DISPOSAL

ALL airbags that are removed from vehicles under this campaign **MUST** be packaged and shipped back to the manufacturer following the manufacturer's instructions. The instructions can be found in the following locations:

- Attached to the dealer letter
- Included in the parts box