

IMPORTANT UPDATE

**TECHNICAL INSTRUCTIONS
FOR
SAFETY RECALL JLI/JLJ/JLK
FRONT PASSENGER AIRBAG INFLATOR REPLACEMENT
CERTAIN 2007 – 2012 MY ES 350**

Update 02/20/2020

Update 2-20-20

- **Inspection added for all repairs. Please see page 12 for details**

The repair quality of covered vehicles is extremely important to Lexus. All dealership technicians performing this recall are required to successfully complete the most current version of the E-Learning course "Safety Recall and Service Campaign Essentials". To ensure that all vehicles have the repair performed correctly:

- **MASTER SERVICE TECHNICIANS**
- **MASTER DIAGNOSTIC SPECIALISTS**

It is the dealership's responsibility to select technicians with the above certification level or greater to perform this recall repair. Carefully review your resources, the technician skill level, and ability before assigning technicians to this repair. It is important to consider technician days off and vacation schedules to ensure there are properly trained technicians available to perform this repair at all times.

NOTE: To support additional service capacity, Lexus Certified and Senior Service Technicians, with at least 36 months Lexus experience AND L652 course credit, may also perform this repair following successful completion of course LSC13B.

I. OPERATION FLOW CHART

The flow chart is for reference only. **DO NOT** use it in place of the full technical instructions. Follow **ALL** steps as outlined in the full technical instructions to confirm the campaign is completed correctly.

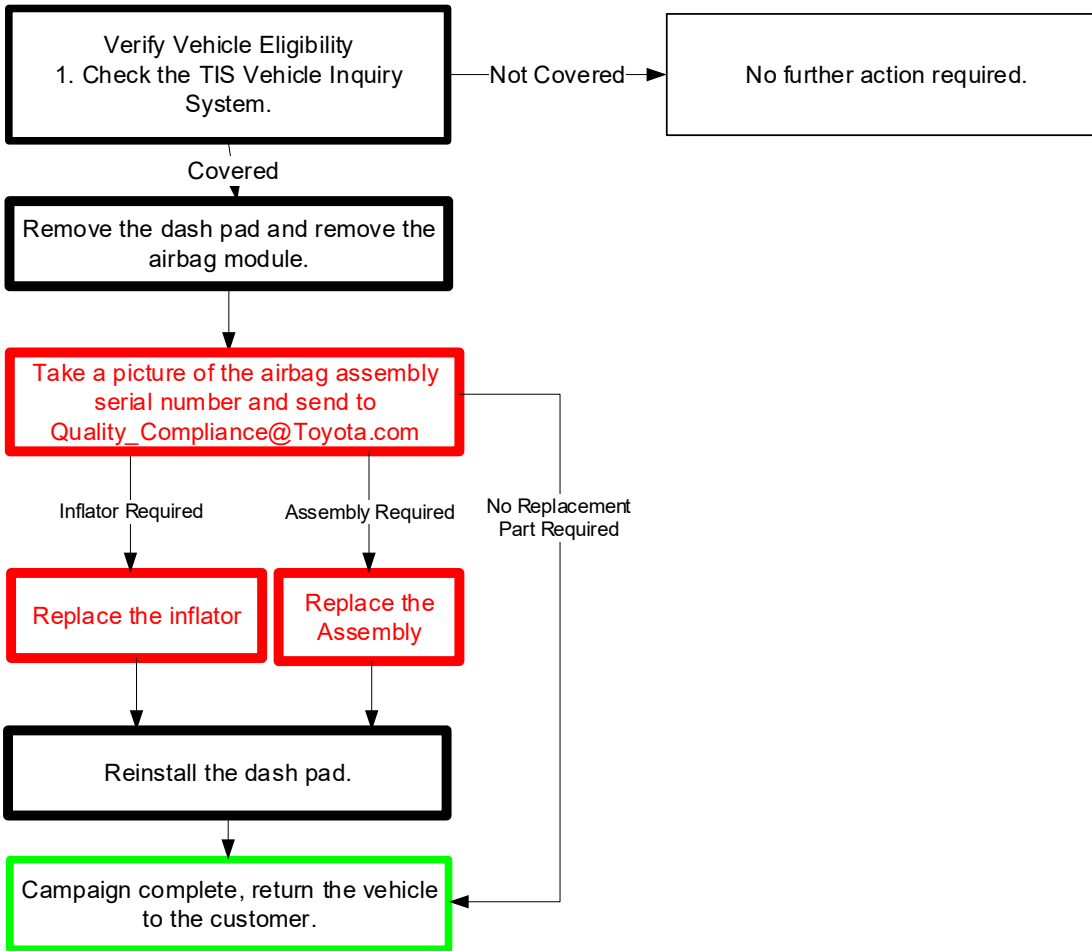

II. BACKGROUND

The subject vehicles are equipped with front passenger airbag inflators produced by Takata. The propellant in these inflators may degrade after prolonged exposure to high absolute humidity and fluctuating high temperatures. Degraded propellant can cause inflator rupture during airbag deployment. In the event of an inflator rupture, metal fragments could pass through the airbag cushion material, striking the vehicle occupants, and result in serious injury or death.

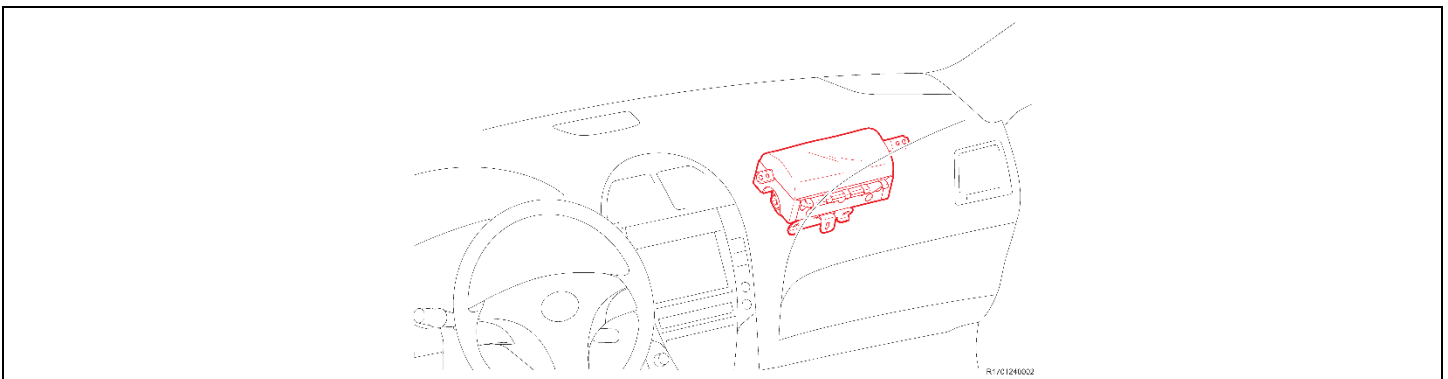

III. IDENTIFICATION OF AFFECTED VEHICLES

A. COVERED VIN RANGE

- Check the TIS Vehicle Inquiry System to confirm the VIN is involved in this Safety Recall, and that the campaign has not already been completed prior to dealer shipment or by another dealer.
- **TMS warranty will not reimburse dealers for repairs conducted on vehicles that are not affected or were completed by another dealer.**

IV. PREPARATION

A. PARTS

Part Number	Part Description	Quantity
04007-06733	Instrument Panel Passenger Airbag Inflator Kit	1
04006-66108*	Front Pillar Garnish Kit (*kit contains 2 clips)	1

Non-Desiccated Part Recovery

Dealers should discontinue the installation of the non-desiccated parts listed below for recall, customer pay repairs AND over-the-counter sales (if applicable).

Model	Model Year	Part Number	Part Description
ES350	2007-2012	73960-33110 73960-33111	AIR BAG ASSY, INSTR PNL PASS L/DOOR

Lexus requires all dealers to return any parts listed above that still remain in dealer inventory by utilizing the Hazmat Part Return Program available. Dealers will be issued a refund for all part returns. This part return program is outlined in *PANT Bulletin 2014-042*.

Important Note:

In order to return the inflator, packages must **NOT** be opened/tampered with.

B. TOOLS & EQUIPMENT

- Standard hand tools
- Torque wrench
- Techstream
- Molding remover set

GLG/GLH CAMPAIGN TOOLS – These tools were previously provided to the dealership for campaign DLC and will be used for this campaign. These tools are required when performing this repair.

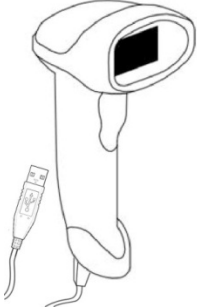
Image	Name	Quantity
	Barcode Scanner	1

NOTE: This tool **CANNOT** be ordered through the parts or tools system. If additional tools are needed, they can be sourced locally.

DLC CAMPAIGN TOOLS – These tools are required when performing this repair.

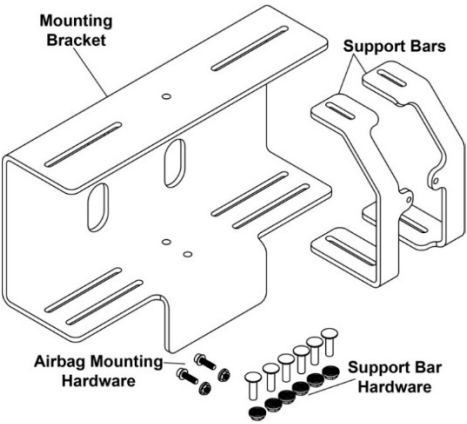
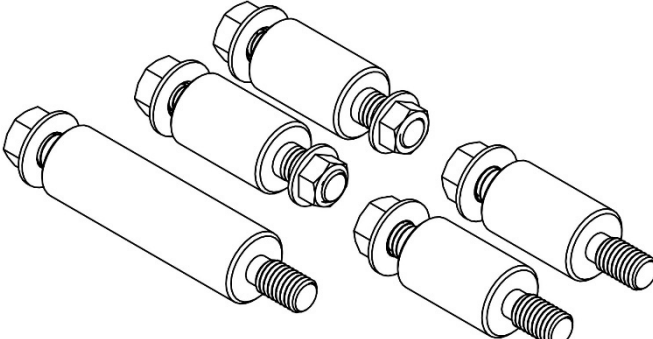
Image	Name	Quantity
 <p>Labels in image: Mounting Bracket, Support Bars, Airbag Mounting Hardware, Support Bar Hardware</p>	Airbag Mounting Bracket & hardware (Provided to the dealership at the launch of SSC DLC)	1
	579943 Adaptor set*	1

*The adaptor set was sent to dealers prior to the start of this campaign.

SST –These are essential service tools that the dealership should have.

Part Number	Part Name	Quantity
09950-50013	Puller C Set *	1
* The set above includes the following tools.		
Part Number	Part Name	Quantity
09951-05010	Hanger 150	1
09952-05010	Slide Arm	2
09953-05020	Center Bolt 150	1
09954-05021	Claw No. 2	2

V. SAFETY PRECAUTIONS



CRITICAL INFORMATION – READ THOROUGHLY



Failure to follow these procedures correctly could cause the SRS to unexpectedly deploy during servicing or the SRS may fail to operate correctly when required after reassembly. Confirm all work is performed as described in these instructions.

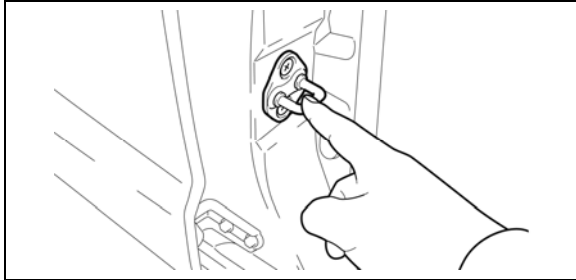

1. ELIMINATE STATIC ELECTRICITY

- a) Before starting work and periodically while working on the vehicle, touch a metallic part of the vehicle to discharge static electricity in the body.



2. DO NOT MEASURE RESISTANCE

- a) **NEVER** measure the resistance of an airbag, this may cause accidental activation.



3. HANDLE THE AIRBAG CAREFULLY

- a) If the airbag is dropped, replace it with a **NEW** one.

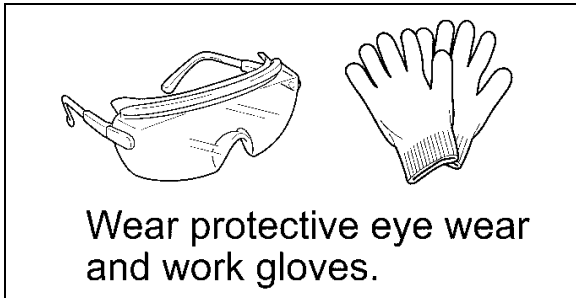

4. WEAR PROTECTIVE EQUIPMENT

- a) Always wear appropriate protective equipment when working on the SRS.

VII. FRONT PASSENGER AIRBAG REMOVAL COMPONENTS



UPPER CONSOLE PANEL ASSEMBLY WITH FRONT ASH RECEPTACLE

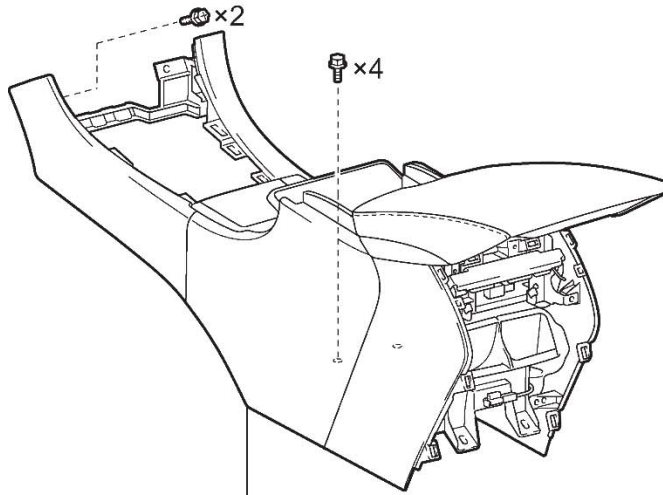
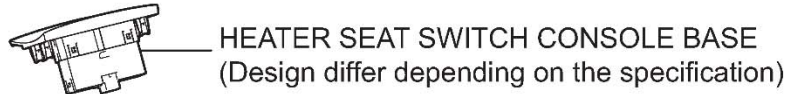
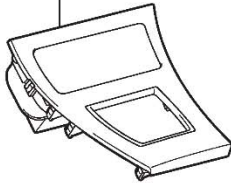

REAR CONSOLE BOX ASSEMBLY
(Design differ depending on the specification)

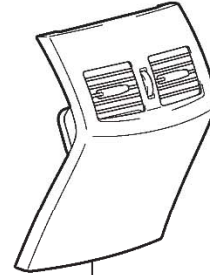

CONSOLE REAR END PANEL SUB-ASSEMBLY

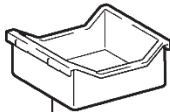

CONSOLE BOX POCKET
(Design differ depending on the specification)

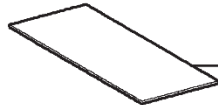

CONSOLE BOX CARPET

R1701240004

TURN SIGNAL SWITCH ASSEMBLY WITH SPIRAL CABLE SUB-ASSEMBLY

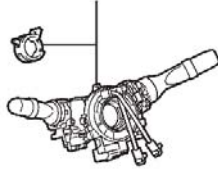

TILT AND TELESCOPIC SWITCH



2.0 (20, 18 in.*lbf)

x2

STEERING COLUMN COVER

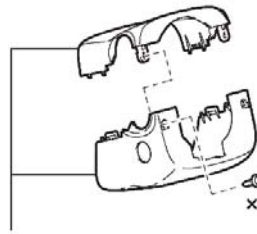

COMBINATION METER ASSEMBLY

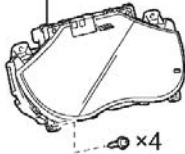

x4

STEERING WHEEL ASSEMBLY



50 (510, 37)

LOWER No. 3 STEERING WHEEL COVER



8.8 (90, 78 in.*lbf)

LOWER No. 2 STEERING WHEEL COVER



INSTRUMENT CLUSTER FINISH PANEL SUB-ASSEMBLY

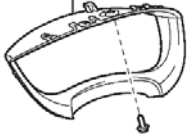

LOWER INSTRUMENT PANEL RH

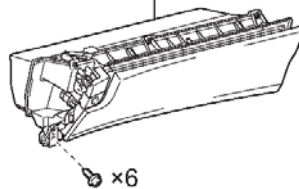

x6

STEERING PAD



SIDE INSTRUMENT PANEL LH

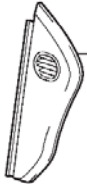

FRONT PASSENGER SIDE KNEE AIRBAG ASSEMBLY

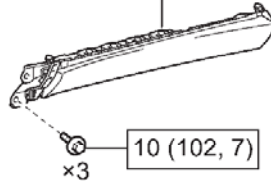

x3

10 (102, 7)

SIDE INSTRUMENT PANEL RH



No. 1 SWITCH HOLE BASE



LOWER INSTRUMENT PANEL SUB-ASSEMBLY

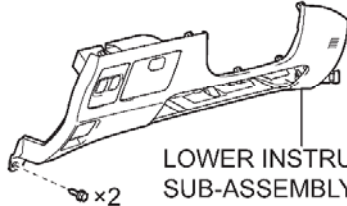

FRONT DOOR OPENING TRIM COVER RH



FRONT DOOR OPENING TRIM COVER LH



INSTRUMENT PANEL FINISH PANEL END RH



FRONT DOOR SCUFF PLATE RH

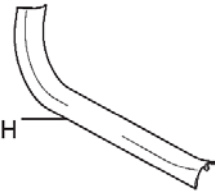

INSTRUMENT PANEL FINISH PANEL END LH



FRONT DOOR SCUFF PLATE LH

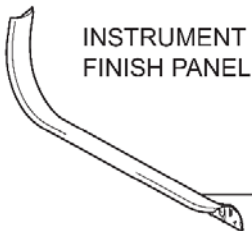

No.2 INSTRUMENT PANEL UNDER COVER SUB-ASSEMBLY

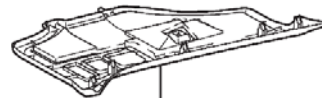

N*m (kgf*cm, ft*lbf) : Specified torque

R1701240005

● FRONT PILLAR GARNISH CLIP

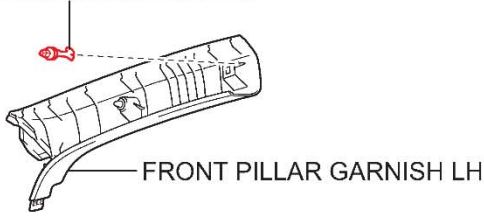

● FRONT PILLAR GARNISH CLIP



No. 1 INSTRUMENT PANEL SPEAKER
PANEL SUB-ASSEMBLY



INSTRUMENT PANEL
SAFETY PAD ASSEMBLY



No. 1 SPEAKER HOLE COVER



No. 2 INSTRUMENT PANEL SPEAKER
PANEL SUB-ASSEMBLY

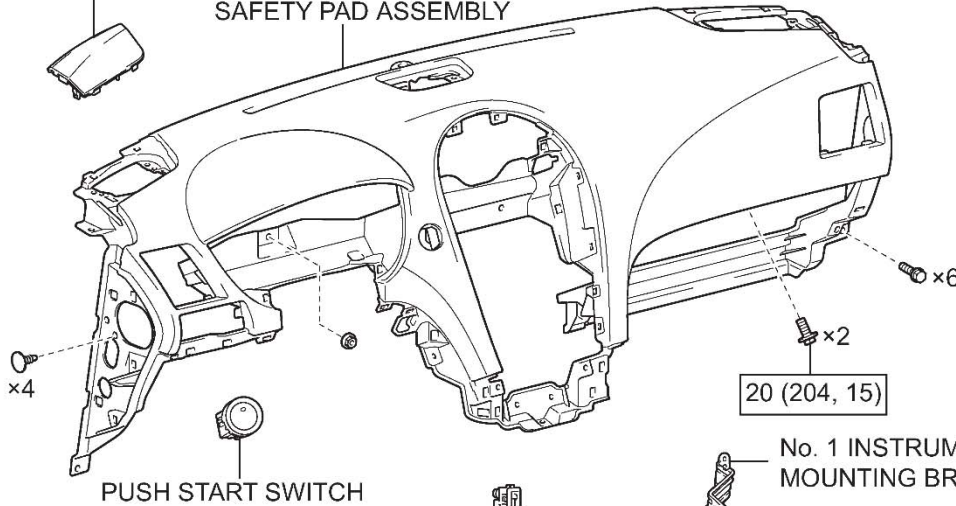

PUSH START SWITCH

ROOM TEMPERATURE SENSOR

20 (204, 15)

No. 1 INSTRUMENT PANEL
MOUNTING BRACKET

FRONT STEREO COMPONENT
SPEAKER ASSEMBLY
(Design differ depending on the specification)



FRONT No. 2 SPEAKER ASSEMBLY
(Design differ depending on the specification)

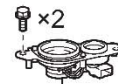

FRONT No. 2 SPEAKER ASSEMBLY
(Design differ depending on the specification)



No. 2 INSTRUMENT PANEL
REGISTER ASSEMBLY

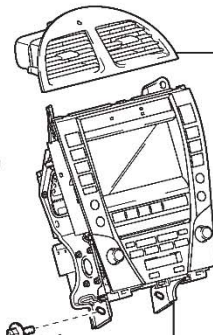

No. 1 INSTRUMENT PANEL
REGISTER ASSEMBLY



No. 3 INSTRUMENT PANEL
REGISTER ASSEMBLY

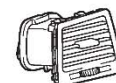

INTEGRATION CONTROL PANEL or
MULTI-DISPLAY or
DISPLAY AND NAVIGATION MODULE DISPLAY
WITH RADIO RECEIVER ASSEMBLY



● Replacement part

N*m (kgf*cm, ft*lb) : Specified torque

R1701240006

3.9 N·m (40, 35 in.*lbf)
Be careful not to
overtighten.

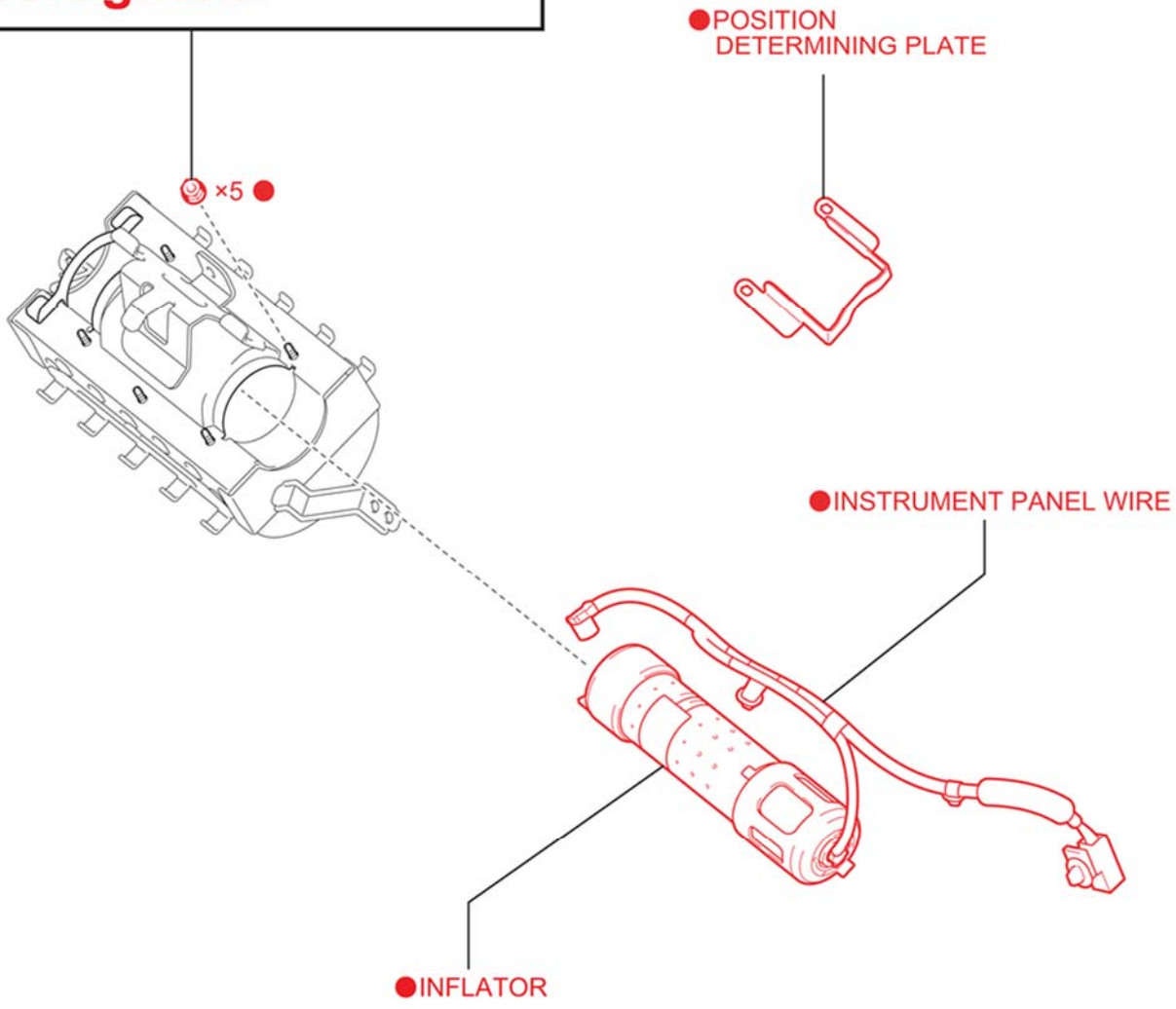

● : Replacement part

R1707250018A01

1. AIRBAG ASSEMBLY REMOVAL



- Wait at least 90 seconds after disconnecting the cable from the negative battery terminal to prevent airbag and seat belt pre-tensioner deployment.
- Follow all precautions as outlined on TIS before servicing the SRS system.

a) Refer to TIS for removal instructions.

2007 MY	2008 MY	2009 MY	2010 MY	2011 MY	2012 MY
-------------------------	-------------------------	-------------------------	-------------------------	-------------------------	-------------------------

2. INSPECT AIRBAG ASSEMBLY

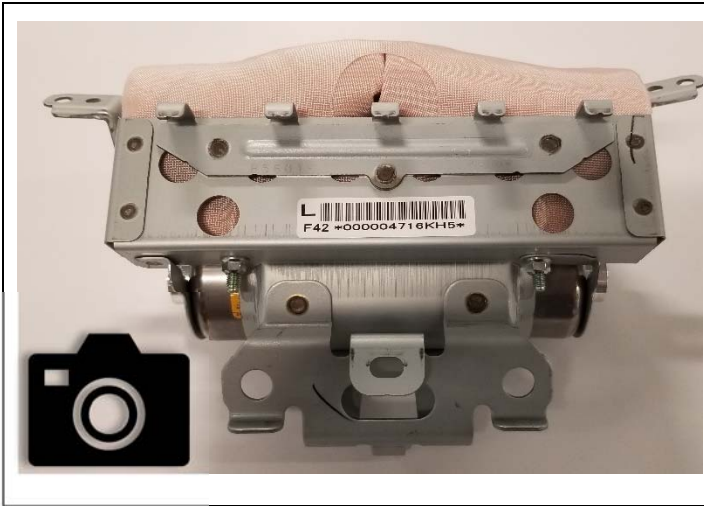

1. TAKE A PICTURE OF THE AIRBAG ASSEMBLY SERIAL NUMBER

- Take a picture of the airbag assembly serial number exactly like the image to the left.
- Email the picture to Quality_Compliance@toyota.com for review.

Email Format

Subject: JLI/JLJ/JLK Airbag Serial Number Review

Body: (Insert Model/Model Year of vehicle)

- You will receive a reply with instructions on how to proceed with the repair.

3. AIRBAG INFLATOR REMOVAL (Only required if instructed by Quality Compliance)

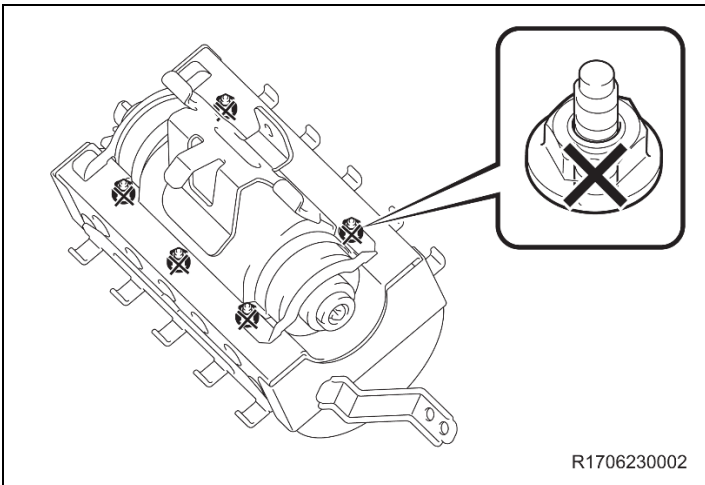

1. REMOVE THE INFLATOR

d) Mark the 5 self locking nuts to prevent reuse.



e) Mount the adaptors (579943-3R3) to the airbag as shown.

NOTE: The 6mm stud mounts to the airbag.



f) Mount the airbag to the mounting bracket as shown.

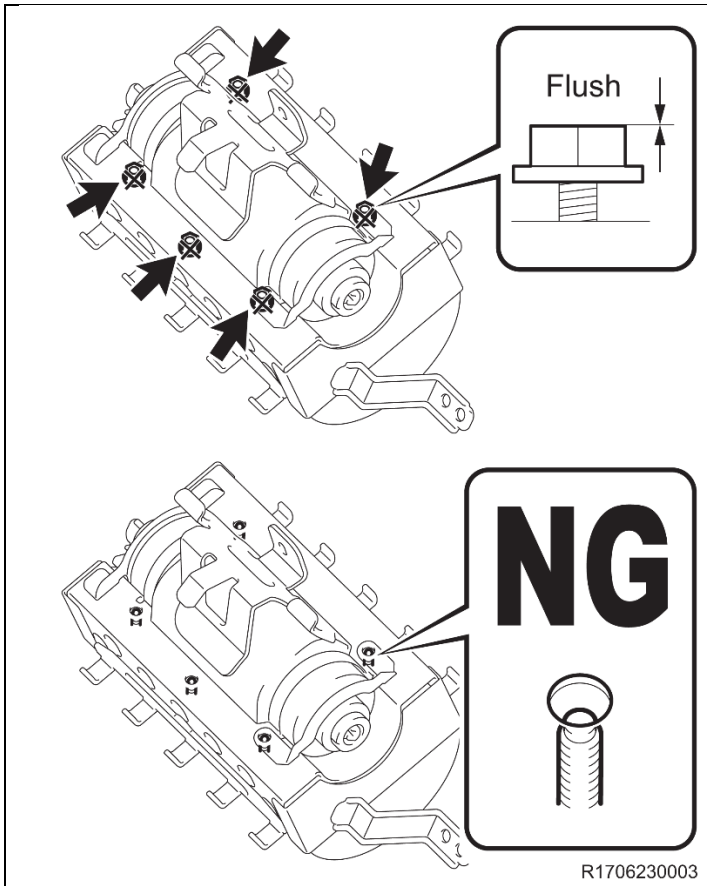

g) Loosen the 5 nuts until each nut is flush with the top of the stud as shown.

NOTE: You may need to slide the airbag to the left or right to access the middle nut. DO NOT use power tools to remove the nuts.

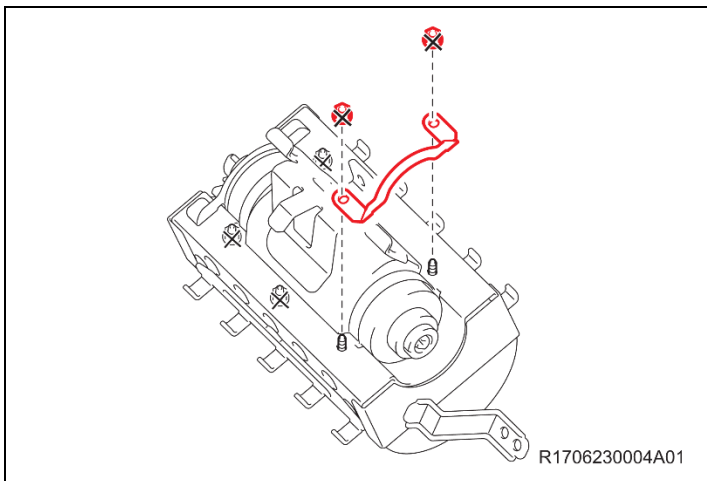

h) Loosen and discard the 2 nuts on the end where the positioning plate is removable.

i) Remove and discard the plate.

NOTE:

DO NOT use power tools.

j) Remove the inflator.

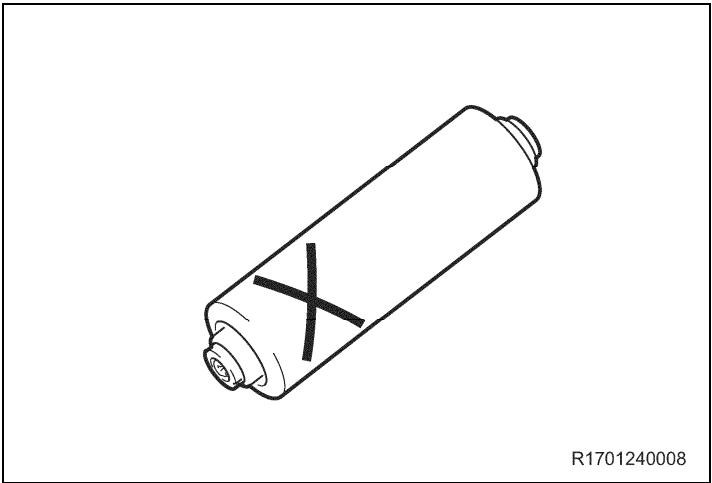
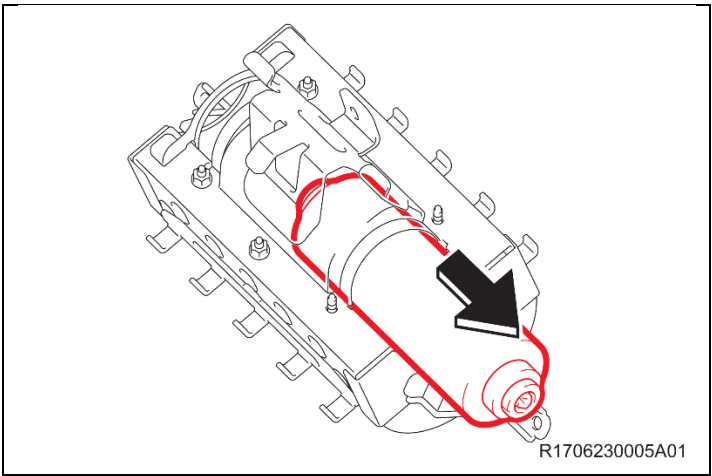

k) Mark the old inflator so it is not reused.
NOTE: Return the old inflator to the parts department for recovery.

VIII. AIRBAG RECORDING

1. LAUNCH THE SERIAL NUMBER RECORDING APPLICATION

Note: The Serial Number Recording Application is the same application used for a prior campaign.



- The serial numbers **MUST** be recorded using a barcode scanner (provided at the launch of SSC DLC).
- The barcode scanner application **MUST** be completed on every vehicle. These numbers **MUST** be included on every warranty claim that is submitted for airbag module replacement or the claim may be subject to debit.
- The technician performing the work **MUST** have valid TIS login credentials and an internet connection to perform the inspection and scanning process.

- Log in to TIS and input the VIN of the vehicle in the Vehicle Inquiry tab.
- Confirm the VIN is applicable and that the campaign has not been completed.
- Click on the link to launch the serial number recording application.

Vehicle Identification Number Search
Enter a 17 Digit VIN below to search for applicable information:
VIN: 1NX BR32E 000000000

Vehicle Information

Division: TOYOTA	Model: Corolla	Grade: CE	Model Year: 2003
Drive Type: 2WD	Body Type: 4Dr. Sedan	Engine Family: 4-cylinder - 1ZZ	Transmission:
Date of First Use:	Production Date: 01/18/2002	Plant Code: Z - FREMONT PLANT - NUMMI	
VIN: 1NX -BR32E-000000000	Standard Equipment: Click here to display		
Exterior Color: 03M5, SANDRIFT METALLIC	Interior Color: FA41, FA41	Interior Trim Color: FA, *	
		Interior Fabric: F, *	

Vehicle accessories are not currently available. Try your query again later.

Service Campaign

Campaign Description: Safety Recall D0F Remedy Notice - 2003-2004 Model Year Corolla, Corolla Matrix, Sequoia, and Tundra Vehicles, 2002-2003 Model Year Vehicle Front Passenger Airbag Inflator Module

Completion Status: Not Completed [Check applicability for VIN](#)

[Show Documents]

- Reenter TIS password in the serial number recording application.

NOTE: The person logged-in to TIS **MUST** be the person performing the repair.

Front Passenger Airbag Inflator Module - Safety Recall
SSC - DSF

User ID: SuzukiR Technician Name: Russell Suzuki
Dealer Code: Dealer Name:
Time: 06/10/2014 02:07 PM PDT Airbag Serial #:
Original Inflator Serial #: Replacement Inflator Serial #:

VIN: STD 8T44... REIFE H, H, J

Mileage*

Task	Dealer	User	Time	Status
Airbag # Record				Not Started
Inflator # Record				Not Started
Terms & Conditions				Not Started
New Airbag #				Not Started

- Record the vehicle mileage into the serial number recording application.

NOTE:

- A task status screen will populate next and at other intervals during the repair. This screen will indicate if the airbag was replaced. Click 'next' to proceed to the next step. This information will be used for record keeping by TMNA.
- If this screen indicates that the campaign has already been completed on this VIN, there is no need to perform the campaign again.

2. CONNECT THE BARCODE SCANNER

- Connect the barcode scanner to the USB port on the Techstream.
- The scanner will automatically connect and a beep will be heard when the scanner is ready.

NOTE:

- The scanner was provided for SSC DLC.
- The barcode scanner works best in low light conditions.
- Always hold the scanner directly in front of and parallel to the barcode label.

3. SCAN THE AIRBAG SERIAL NUMBER

ATTENTION: This information is **CRITICAL**

- Scan the **AIRBAG ASSEMBLY** serial number 2 times.
 - Confirm that the cursor is in the first serial number box and scan the bar code.
 - Position the cursor in the second serial number box and rescan the bar code.
- Click next.

NOTE:

- If both serial numbers do not match, confirm and reenter.
- If the serial number barcode will not scan, it can be entered manually.

AIRBAG SERIAL NUMBER IDENTIFICATION

- The airbag serial number is **ALWAYS** the **12 DIGITS** located between the asterisks.
- The **3 digits** before the asterisk **ARE NOT** part of the serial number, and **SHOULD NOT** be entered or an inaccurate response may be returned.

Airbag Serial Number Label Example



The **AIRBAG ASSEMBLY** serial number **MUST** be recorded prior to replacement.

Front Passenger Airbag Inflator Module - Safety Recall

SSC DSC

1 2 3 4 5

User ID:

Technician Name:

Dealer Code:

Dealer Name:

Time: 03/30/2015 05:15 AM PDT

VIN: 1NX BR32E 14Z308698 [2004 Corolla SUPER WHITE]

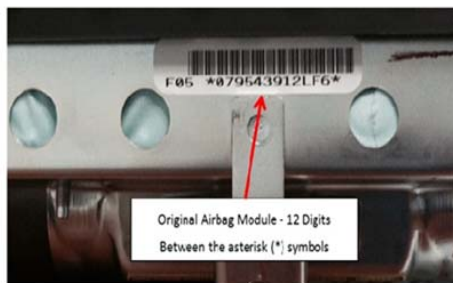

Original Airbag Module - 12 Digits
Between the asterisk (*) symbols

Record Airbag Serial Number

[How to identify an Airbag module Assembly number?](#)

The Airbag module Assembly serial number is a 12 digit code. It can be found along with a bar code on opening the Airbag assembly unit. To manually enter these details into the application, the technician has to identify the 12 digit code between two Asterisks (*) inside the Airbag assembly unit. The first seven characters of this 12 digit code are numbers and the 10th digit is either 'K' or 'L' always.

Use of a barcode scanner is strongly recommended when entering Airbag Assembly Serial Number.

If manually typing serial number, you MUST include all leading zeros. (If applicable)

* Airbag Assembly Serial Number:

* Reconfirm Airbag Assembly Serial Number:

If original Airbag Assembly serial number is not visible or missing, check this box:

(*) - Indicates Required Field(s)

Clear Next

Front Passenger Airbag Inflator Module - Safety Recall

SSC - E04



User ID:

Dealer Code:

Time: 03/30/2015 05:17 AM PDT

VIN: 1NX BR32E 14Z308698 [2004 Corolla SUPER WHITE]

Technician Name:

Dealer Name:

Airbag Serial #: *****12

Original Inflator

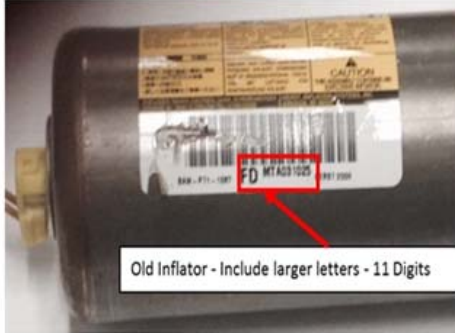

How to Identify the Inflator serial code on the Original and Replacement Inflator can?

The Inflator serial code is an 11 digit code on the Inflator can. It can be found with a bar code on removing the Inflator can from the Airbag Assembly unit.

The first two characters of the Original Inflator Serial code will be from [AA, AB, AJ, FD or JD].

The first two characters of the Replacement Inflator Serial code will be either 'LT' or 'LR'.

Replacement Inflator



Inflator Module replacement IS REQUIRED on all vehicles under the Safety Recall. Follow the technical instructions and acknowledge the following statements.

If manually typing serial number, you MUST include all leading zeros. (If applicable)

Original Inflator Serial #:

If old inflator serial number is not visible or missing, check this box.

Replacement Inflator Serial #:

If you have a concern with the inflator serial numbers, please email quality_compliance@toyota.com with details.

- I agree to complete the safety recall's remaining technical instructions.
- I agree to perform a vehicle Health Check with Techstream upon completion of the safety recall's technical instructions.

(*) - Indicates Required Field(s)

c) Confirm agreement by checking the two boxes and press submit.

d) Record the Warranty Authorization # to be included in the warranty claim.

Front Passenger Airbag Inflator Module - Safety Recall
SSC - DSF

1 2 3 4 5

User ID: SuzukiR **Technician Name:** Russell Suzuki
Dealer Code: **Dealer Name:**
Time: 06/10/2014 05:13 PM PDT **Airbag Serial #:** *****96
Original Inflator Serial #: AAEL5110212 **Replacement Inflator Serial #:** AAEL5110213

SuzukiR has agreed to the following terms and conditions on 06/10/2014 05:13 PM PDT

- * I agree to complete the safety recall's remaining technical instructions.
- * I agree to perform a vehicle Health Check with Techstream upon completion of the safety recall's technical instructions.

Russell Suzuki has successfully confirmed completion of Airbag Inflator Module Safety Recall for
VIN - 5TD BT44A 33S157291 [2003 Sequoia BEIGE M. M.]
Warranty Authorization #: b5511e9f
Airbag inflator module was replaced under this safety recall.
Print this page for your records and then click 'Close' to resume working.

Close

e) Confirm agreement by checking the two boxes.

f) Place the old airbag in the parts box and return it to the parts department.

NOTE:

- **Keep all shipping paperwork with the box that it came in.**
- **Confirm the cursor is in the correct serial number input box before scanning.**
- **If the serial number barcode will not scan, it can be entered manually.**
- **If there are any difficulties or concerns with this process, email quality_compliance@toyota.com with details.**

NEW AIRBAG ASSEMBLY RECORDING



If the airbag serial number and barcode are not legible or are not present, check the box in the application indicating the serial number is not legible.

a) If the airbag serial number cannot be scanned or is not present check the box as shown below.

Front Passenger Airbag Inflator Module - Safety Recall
SSC DSC

(1) (2) (3) (4) (5)

User ID: _____ Technician Name: _____
Dealer Code: _____ Dealer Name: _____
Time: 03/30/2015 05:15 AM PDT VIN: 1NX BR32E 14Z308698 [2004 Corolla SUPER WHITE]

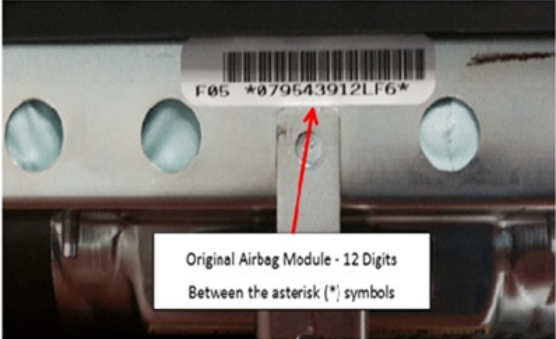

Record Airbag Serial Number

[How to Identify an Airbag module Assembly number?](#)

The Airbag module Assembly serial number is a 12 digit code. It can be found along with a bar code on opening the Airbag assembly unit. To manually enter these details into the application, the technician has to identify the 12 digit code between two Asterisks (*) inside the Airbag assembly unit. The first seven characters of this 12 digit code are numbers and the 10th digit is either 'K' or 'L' always.

Use of a barcode scanner is strongly recommended when entering Airbag Assembly Serial Number.
If manually typing serial number, you MUST include all leading zeros. (If applicable)

* Airbag Assembly Serial Number:
* Reconfirm Airbag Assembly Serial Number:

If original Airbag Assembly serial number is not visible or missing, check this box

(*) - Indicates Required Field(s)

**Check this box if the Airbag serial number is not legible.
Note: Contact your area office in the event you are unable to read the serial number
DO NOT ATTEMPT TO INSTALL THE INFLATOR**

- b) After the Area office approves the Airbag replacement and the new part is received, scan the new Airbag barcode in the Serial Number Recording Application.

Front Passenger Airbag Inflator Module - Safety Recall

SSC DSC

1 2 3 4 5

User ID: _____ Technician Name: _____
Dealer Code: _____ Dealer Name: _____
Time: 03/30/2015 05:15 AM PDT VIN: 1NX BR32E 14Z308698 [2004 Corolla SUPER WHITE]



Original Airbag Module - 12 Digits
Between the asterisk (*) symbols

[How to Identify an Airbag module Assembly number?](#)

The Airbag module Assembly serial number is a **12 digit code**. It can be found along with a bar code on opening the Airbag assembly unit. To manually enter these details into the application, the technician has to identify the 12 digit code between two Asterisks (*) inside the Airbag assembly unit. The first seven characters of this 12 digit code are numbers and the 10th digit is either 'K' or 'L' always.

Record Airbag Serial Number

Use of a barcode scanner is strongly recommended when entering Airbag Assembly Serial Number.

If manually typing serial number, you MUST include all leading zeros. (If applicable)

*New Airbag Assembly Serial Number:

I agree to complete the safety recall's remaining technical instructions.
 I agree to perform a vehicle Health Check with Techstream upon completion of the safety recall's technical instructions.

(*) - Indicates Required Field(s)

- c) Confirm agreement by checking the two boxes and press next to advance to the Warranty authorization screen.
- d) Return the old airbag to the parts department.
- e) Proceed to Section IX Step 2.



The new **AIRBAG ASSEMBLY** serial number **MUST** be recorded prior to reinstallation to track the airbag assembly to the vehicle.

IX. AIRBAG INFLATOR INSTALLATION (Only required if instructed by Quality Compliance)

a) Install the inflator as shown below and ensure the inflator is oriented in the correct position as shown below.



STOP

- Make sure to follow the installation procedure carefully as the instrument panel wire connector cannot be disconnected once connected
- Make sure the inflator is correctly positioned.
- The inflator cannot be fully inserted if it is upside down.

Check orientation
Upper side

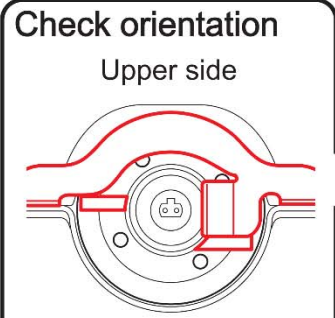

Bottom

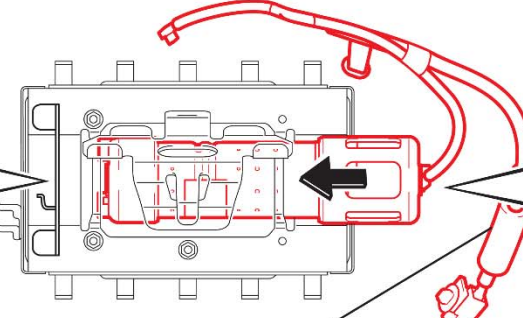

Instrument panel wire

Check orientation
Upper side

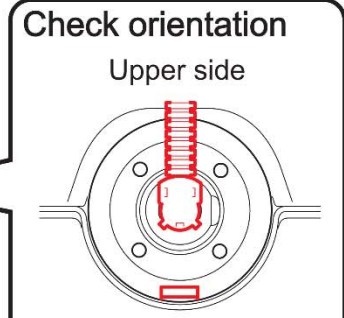

Bottom

R1707250019A02

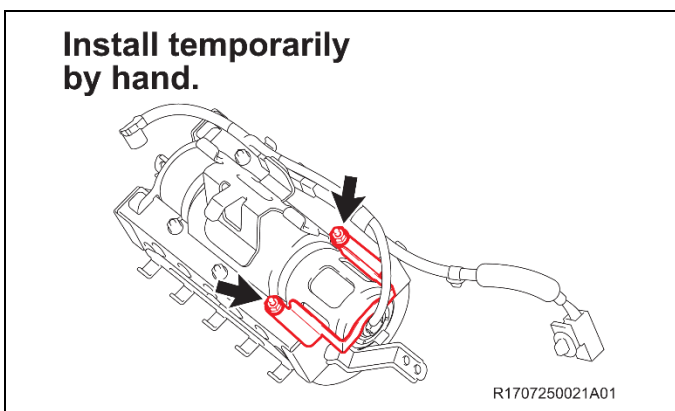
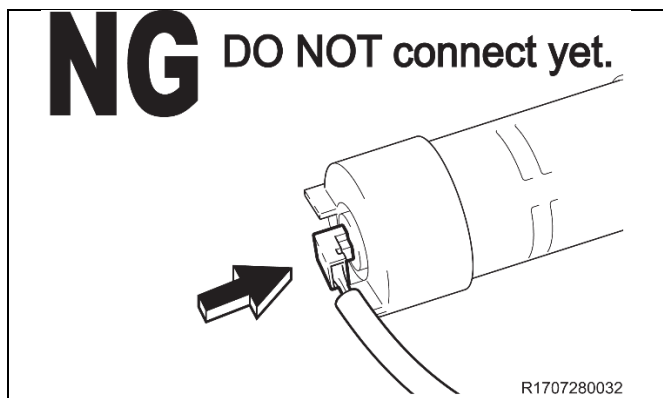

- f) Install the **NEW** positioner plate.
g) Temporarily install 2 **NEW** nuts.

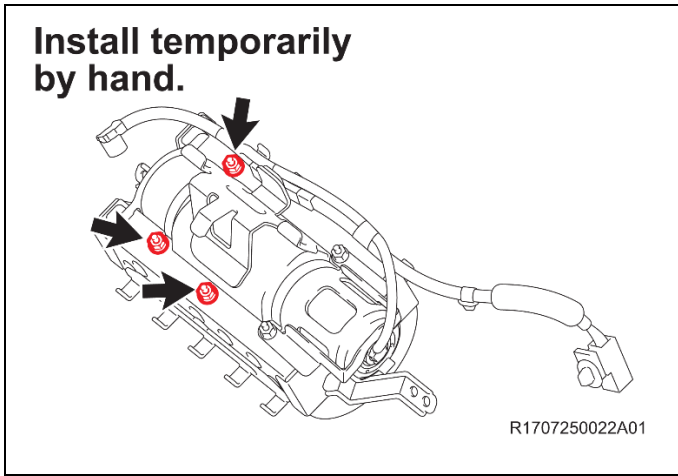

- h) Remove and discard the 3 remaining nuts.
- i) Temporarily install 3 **NEW** nuts.

j) Push the inflator towards the position determining plate and eliminate any gaps.



- If any gaps exist, the flats may move apart and could result in abnormal operation during airbag deployment.

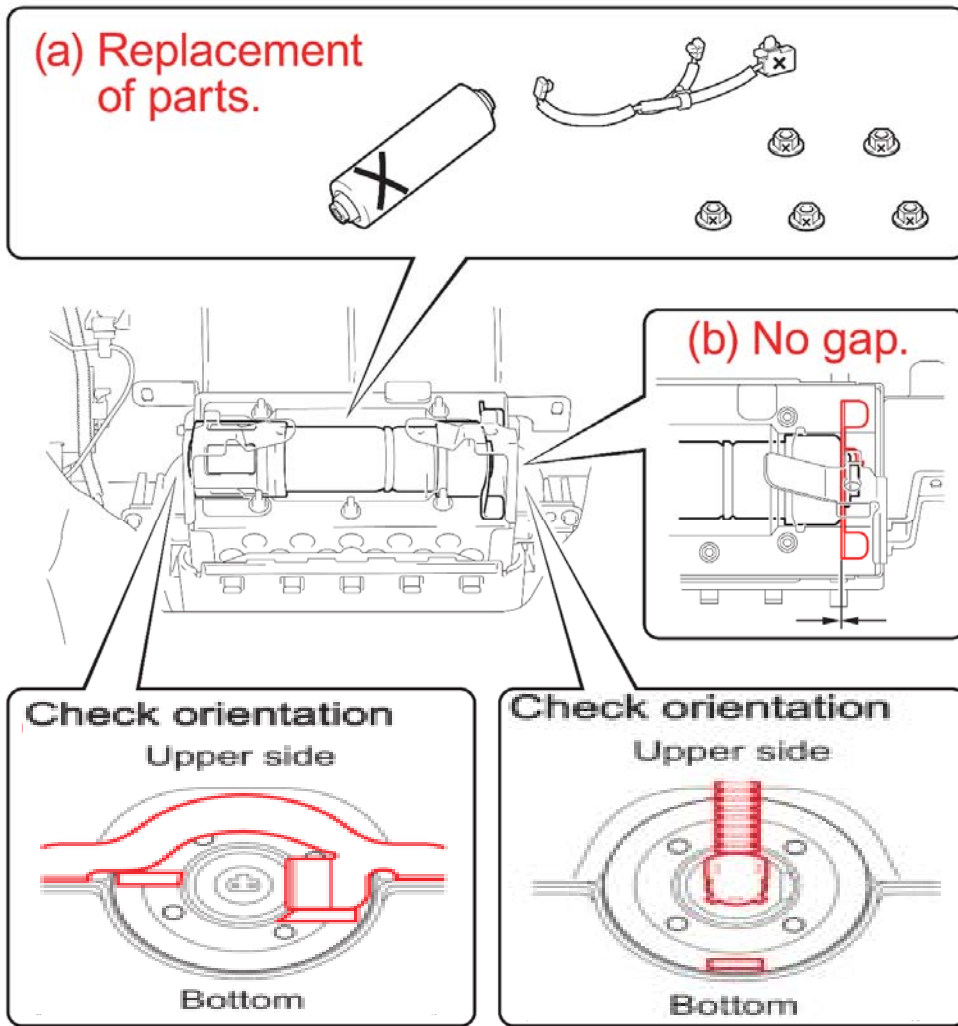

R1701260003Z01

k) Tighten the 5 nuts evenly in several increments in the sequence shown. Use a socket driver or torque wrench to tighten the nuts.

Torque: 35 in. lbf (3.9N·m)



- There will be some resistance when tightening the nuts because they are self-locking, confirm the nuts are tightened correctly.
- **DO NOT** use a power tool, T-handle, or ratchet when tightening the nuts to avoid over torqueing and deforming the studs.
- You may need to slide the airbag to the left or right with in the mounting bracket to access the center nut.

OK

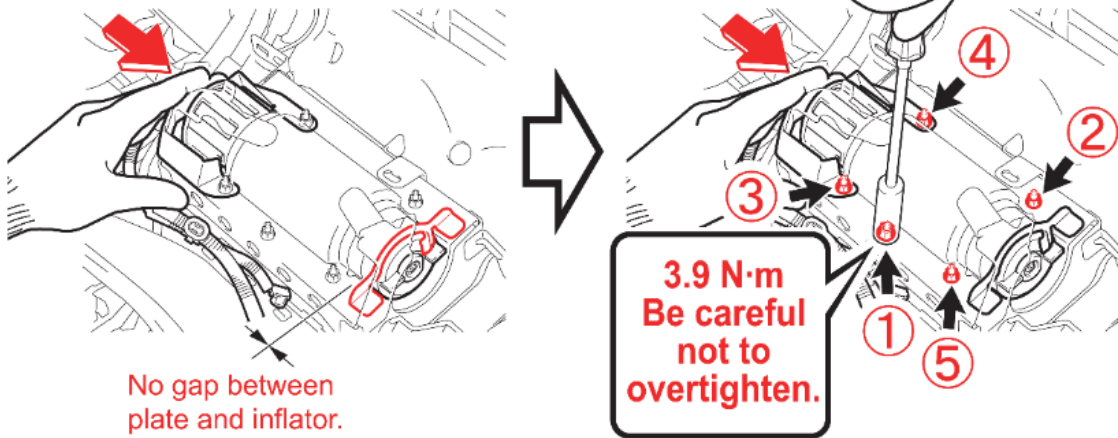

NG

NG

NG



These tools cause overtightening !

R1701260011Z01

- l) Connect the airbag connector to the instrument panel passenger airbag assembly and then push in the airbag connector lock as shown in the illustration.
- m) Engage the clamp.



- Make sure to correctly align the connectors before connecting them.
- Make sure that the airbag connector is securely connected.

ALIGN CONNECTORS

Wire Harness Side:

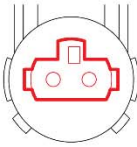

Inflator Side:

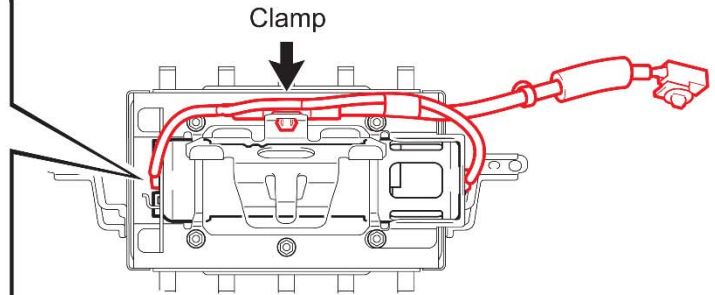

R1707280031

X. AIRBAG ASSMEBLY INSTALLATION

1. INSTALL THE NEW AIRBAG ASSEMBLY INTO THE INSTRUMENT PANEL

2. REINSTALL THE DASH

a) Refer to TIS for reinstallation instructions

2007 MY	2008 MY	2009 MY	2010 MY	2011 MY	2012 MY
-------------------------	-------------------------	-------------------------	-------------------------	-------------------------	-------------------------

3. RECONNECT THE NEGATIVE BATTERY CABLE

4. PERFORM A HEALTH CHECK AND DIAGNOSTIC REPORT

5. PERFORM ANY NEEDED SYSTEM INTIALIZATIONS

◀ VERIFY REPAIR QUALITY ▶

- Confirm all precautions are followed to ensure safety during the repair
 - Confirm the entire serial number checker application is completed and the warranty authorization # is recorded on *EVERY* vehicle
 - Confirm the old airbag is handled safely and given to the appropriate parts professional for shipment
- If you have any questions regarding this update, please contact your area representative.

XI. APPENDIX

A. CAMPAIGN DESIGNATION DECODER

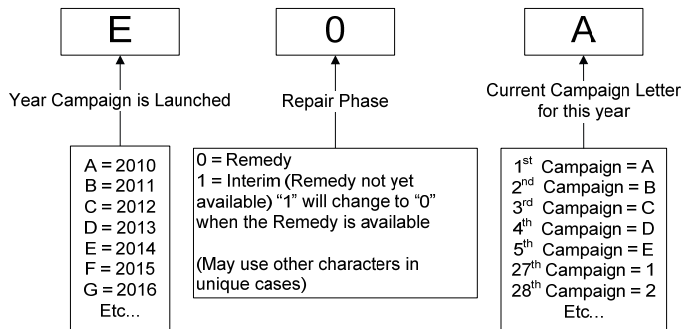

Examples:

A0D = Launched in 2010, Remedy Phase, 4th Campaign Launched in 2010

B1E = Launched in 2011, Interim Phase, 5th Campaign Launched in 2011

C1C = Launched in 2012, Interim Phase, 3rd Campaign Launched in 2012

B. CAMPAIGN PARTS DISPOSAL

ALL airbags that are removed from vehicles under this campaign **MUST** be packaged and shipped back to the manufacturer following the manufacturer's instructions. The instructions can be found in the following locations:

- Attached to the dealer letter
- Included in the parts box