

**December 21, 2018**

Version 2

## Safety Recall: Power Sliding Door Rear Latches

Supersedes 18-128, dated November 10, 2018, to revise the information highlighted in **yellow**.

### AFFECTED VEHICLES

Year	Model	Trim	VIN Range
2018-19	Odyssey	ALL except LX	Check the iN VIN status for eligibility.

### REVISION SUMMARY

- Under REPAIR PROCEDURE, steps were added.
- Parts are available to repair vehicles. **Do not disable the power sliding door**; the power sliding door disable procedure was removed.

**NOTE**

**If you did the power sliding door disable procedure on or before December 20, 2018**, the warranty claim information is included so that dealers can file a claim.

### BACKGROUND

The rear latch assemblies on the power sliding doors may generate higher than normal friction, causing the mechanism to stick. A stuck rear latch mechanism may restrict doors from fully closing, allowing the doors to open unexpectedly and increasing the risk of injury for occupants seated in the second and third row seats.

### CUSTOMER NOTIFICATION

Owners of affected vehicles will be sent a notification of this campaign.

Do an iN VIN status inquiry to make sure the vehicle is shown as eligible.

Some vehicles affected by this campaign may be in your new or used vehicle inventory.

Failure to repair a vehicle subject to a recall or campaign may subject your dealership to claims or lawsuits from the customer or anyone else harmed as a result of such failure. To see if a vehicle in inventory is affected by this safety recall, do a VIN status inquiry before selling it.

### CORRECTIVE ACTION

Replace both the left and right power sliding door rear latches.

**CUSTOMER INFORMATION:**The information in this bulletin is intended for use only by skilled technicians who have the proper tools, equipment, and training to correctly and safely maintain your vehicle. These procedures should not be attempted by "do-it-yourselfers," and you should not assume this bulletin applies to your vehicle, or that your vehicle has the condition described. To determine whether this information applies, contact an authorized Honda automobile dealer.

## PARTS INFORMATION

Part Name	Part Number	Quantity
Power Sliding Door Latch Assembly Kit (Includes Both Left and Right Side)	06720-THR-308	1

## WARRANTY CLAIM INFORMATION

Operation Number	Description	Flat Rate Time	Defect Code	Symptom Code	Template ID	Failed Part Number
7441E4	Replace both the left and right power sliding door rear latches.	1.6 hr	6PS00	O3600	A18128A	72650-THR-A11

Use the following warranty information if the power sliding door needs to be enabled after the power sliding door latches were replaced.

Operation Number	Description	Flat Rate Time	Defect Code	Symptom Code	Template ID	Failed Part Number
7441E4	Replace both the left and right power sliding door rear latches.	1.6 hr	6PS00	O3600	A18128C	72650-THR-A11
A	Install the fuses and connect the power sliding door switch to enable the power sliding doors.	0.1 hr				

Skill Level: Repair Technician

### NOTE

**Parts are available to replace the door latches. Do not disable the power sliding door.** If you did the power sliding door disable procedure **on or before December 20, 2018**, file a claim using the warranty claim information below.

7370E0	Remove the fuses and disconnect the power sliding door switch to disable the power sliding doors.	0.3 hr	6PD00	Z3300	A18128B	72650-THR-A11
--------	---	--------	-------	-------	---------	---------------

## REPAIR PROCEDURE

### NOTE

The images in this repair procedure show the left side of the vehicle. The right side is a mirror image of these images.

1. Remove the second row outer seats.

### NOTE

Remove any child or booster seats that are installed in the second row seats, and place them in the cargo area for the customer to reinstall.

2. Lower both power sliding door windows to the fully open position.
3. Remove the air intake duct.

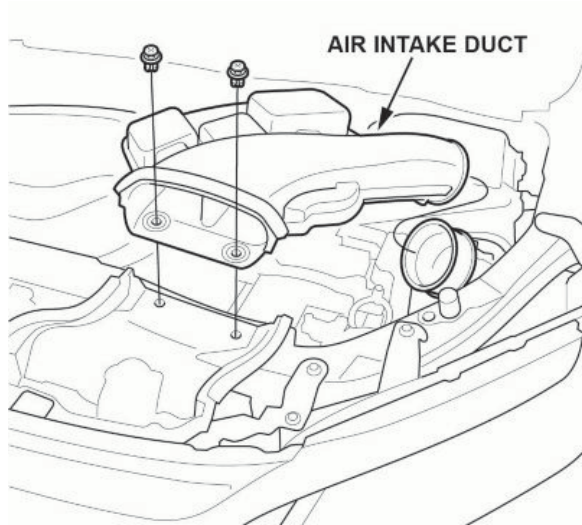

4. Disconnect the 12-volt battery.

### NOTES

- Always disconnect the negative terminal first.

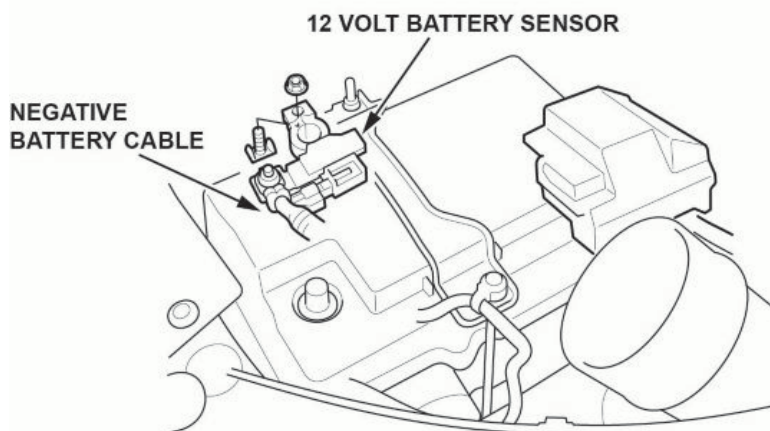

- To protect the battery sensor connector from damage, do not hold it when removing the terminal.
  - Do not disconnect the 12-volt battery sensor from the cable.
- 4.1. Make sure the ignition is turned to OFF.
  - 4.2. Disconnect and isolate the negative cable with the 12-volt battery sensor from the 12-volt battery.

5. Using a wire hook, pull the clip off of the inner handle shaft, and remove the inner handle.

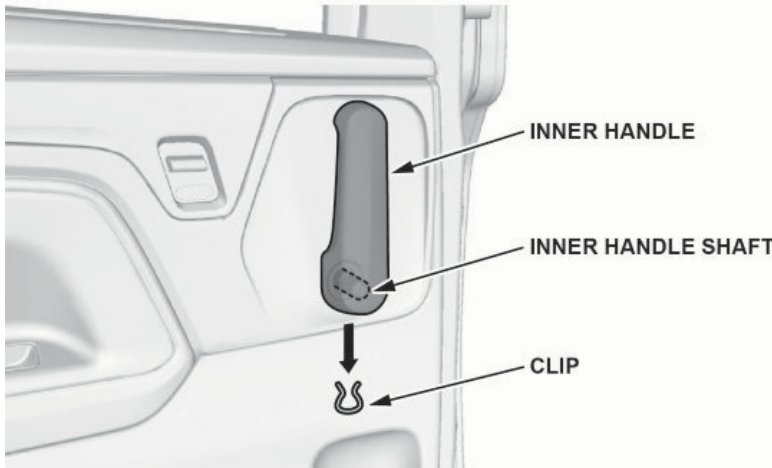

6. Remove the two clips at the bottom of the door panel first to release the lower door seal from the door panel.

**NOTE**

Removing the two clips prevents pulling the door seal off of the door as the door panel is lifted and removed.

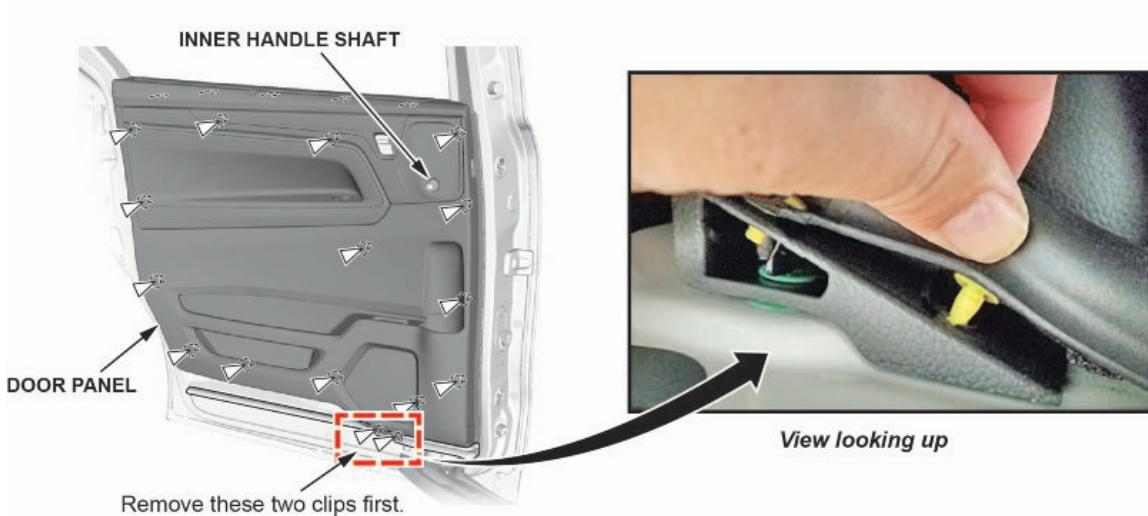

7. Starting at the bottom edge of the door panel, remove the remaining clips with a commercially available trim pad remover.

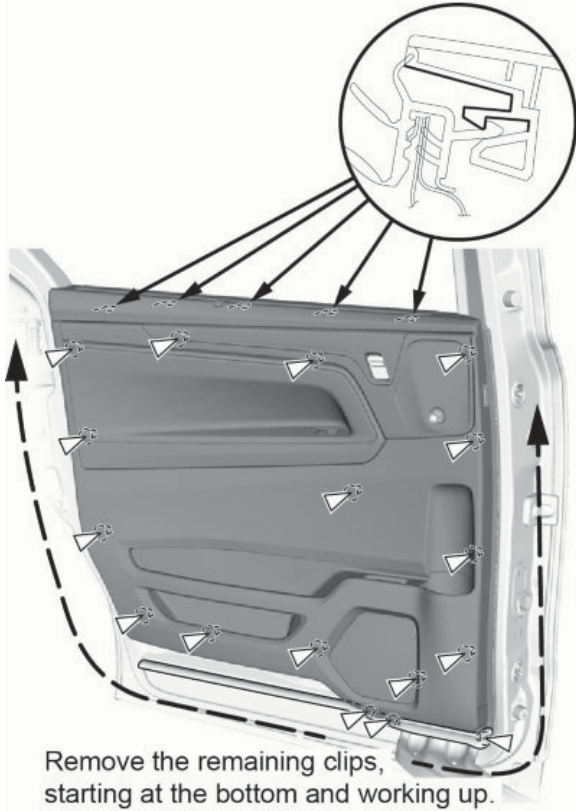

8. Starting at the rear, pull the door panel upward while making sure the clips from step 6 are free and not pulling on the lower door seal. Pull the door panel away from the inner handle shaft, and lift it upward.
9. While holding the sliding door panel away from the door, disconnect the connector. Then, remove the door panel.

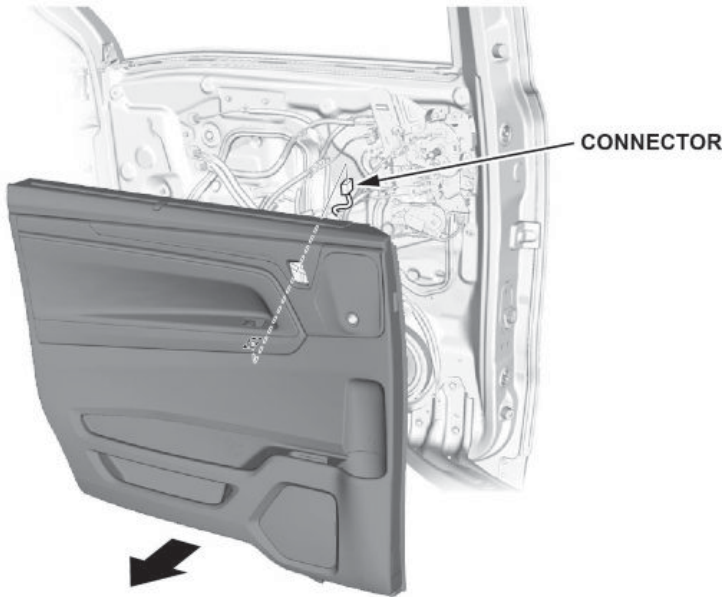

10. Remove the sliding door panel barrier.

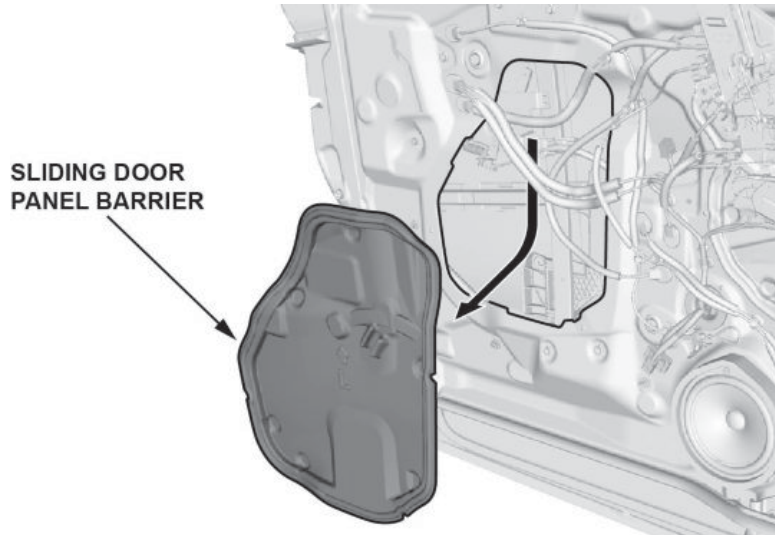

11. Remove the sliding door glass bolts from the regulator.

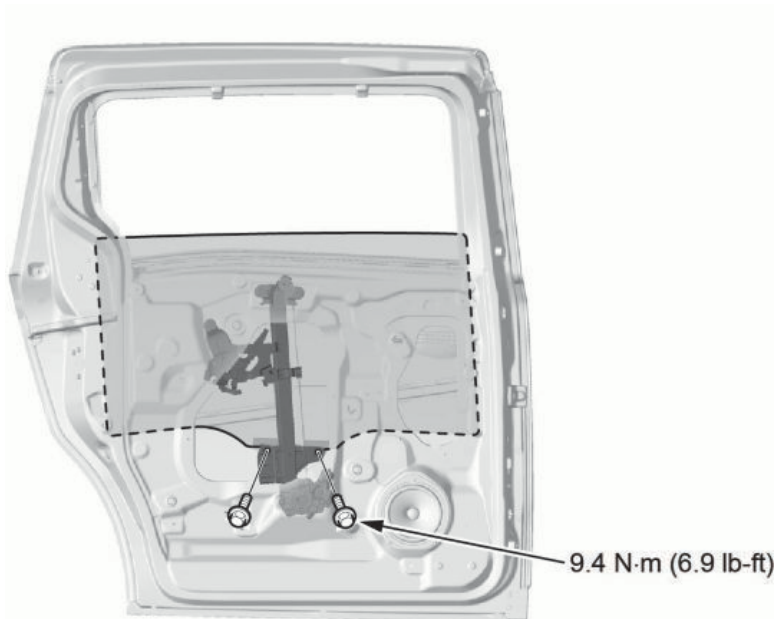

12. Slide the window up, and apply low-tack tape to the outside of the glass and the sliding door as shown to hold the window in the fully closed position.

Pull the window up to the fully closed position.



Apply tape on the outside to hold the window in place.



13. Remove the five regulator bolts, and slide the window regulator forward into the door cavity as shown.

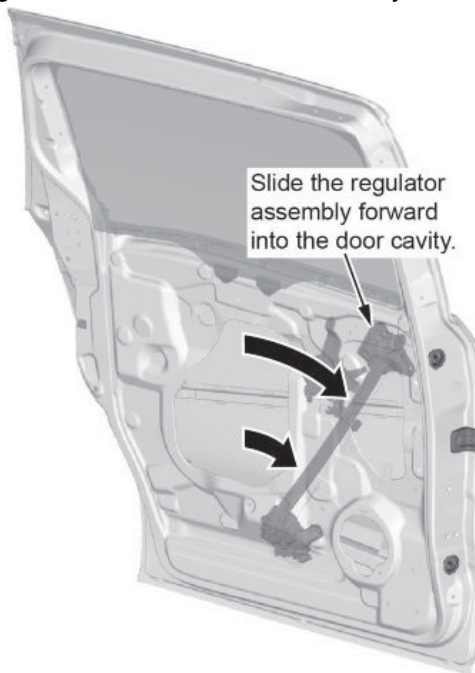
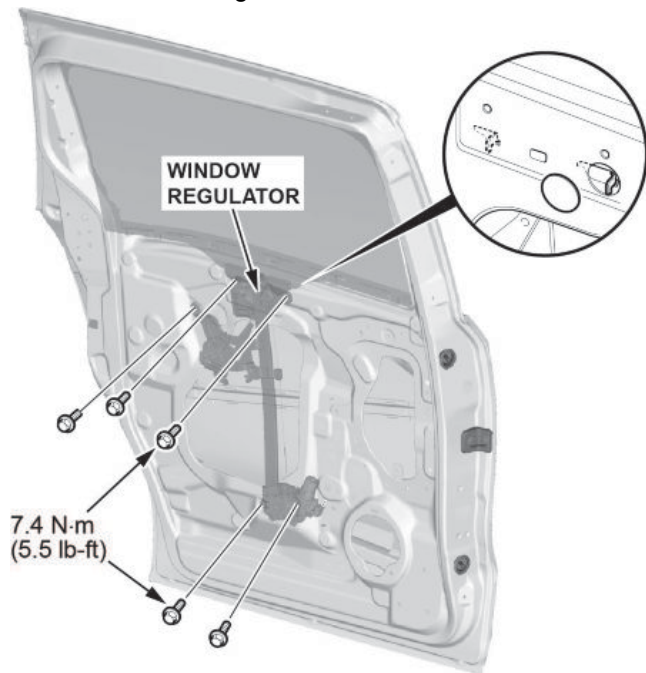

14. Install a zip tie through the window glass mounting bracket hole and the body as shown.

Loop the tie through the body and the window glass mounting bracket hole.

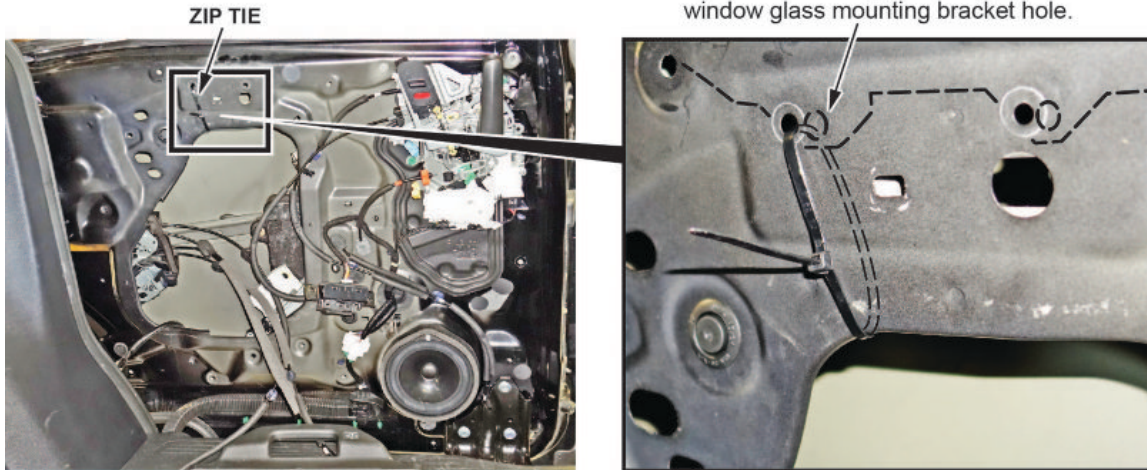

15. Remove the lower bolt from the sliding door rear run channel.

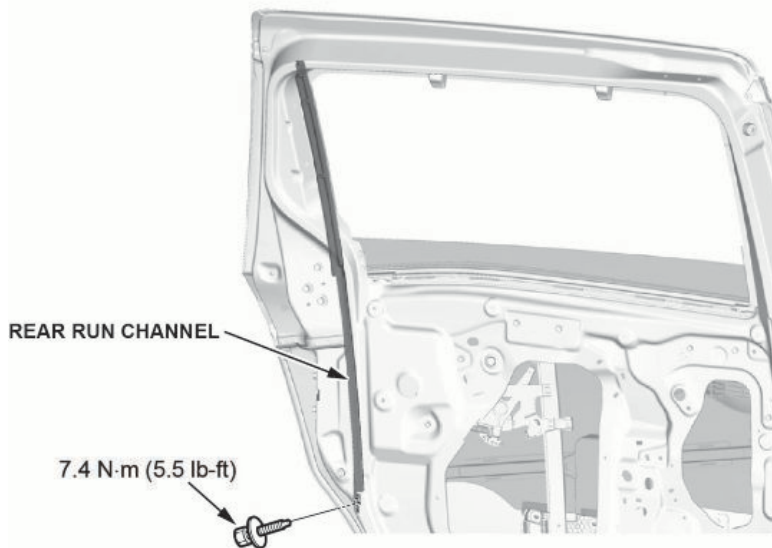



16. Release the cable holders and the cable fasteners.

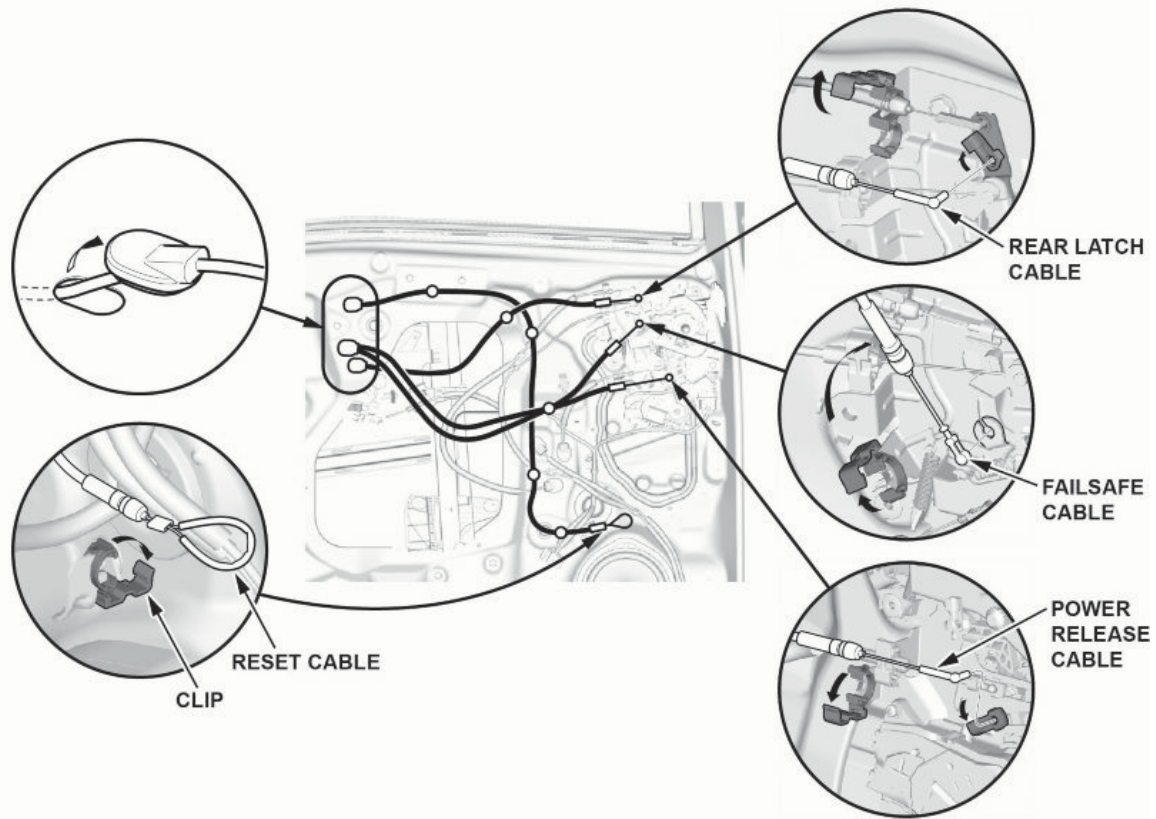

17. Disconnect the rear latch cable, the failsafe cable, the power release cable, and the reset cable.

18. Push the cable grommets in through the cable openings. Then, pull the cables into the door cavity and out through the sliding door panel barrier opening.

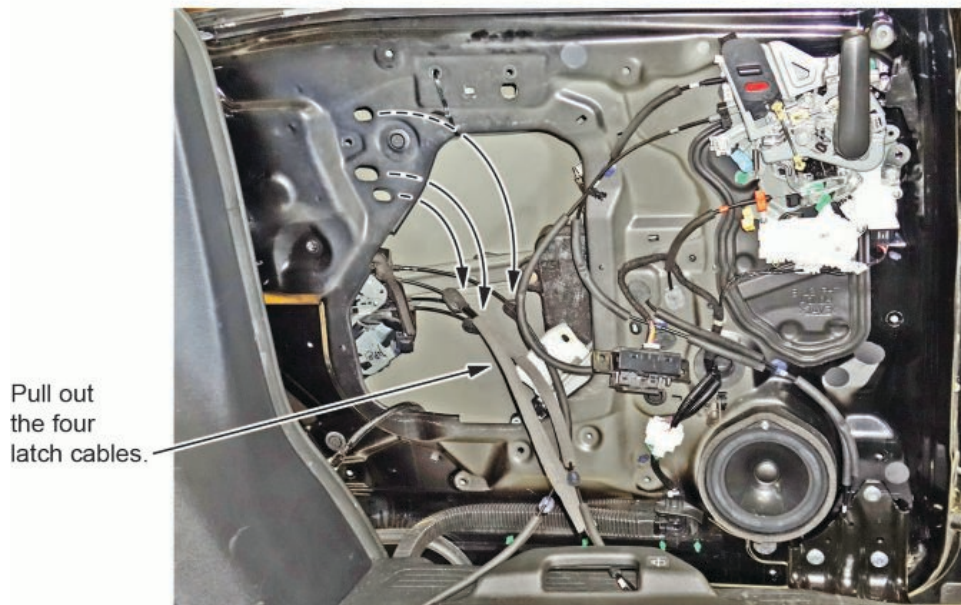

19. Remove the four rear latch fastener bolts and the clip.

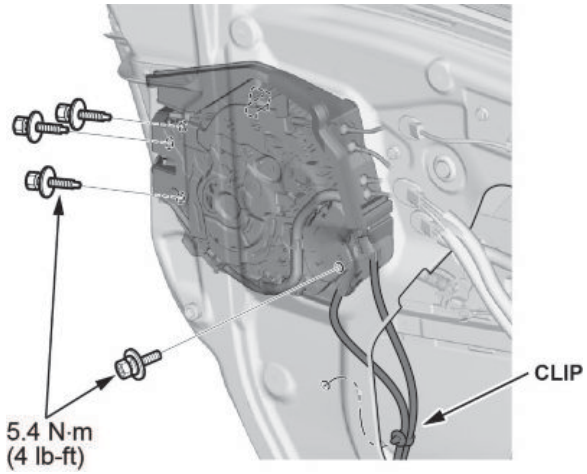

20. Sit in the open door with one leg on either side of the lower roller bracket, and pull the door forward to access the rear latch opening as shown.



21. While pushing the bottom of the sliding door rear run channel outward, pull the rear latch forward into the door cavity.

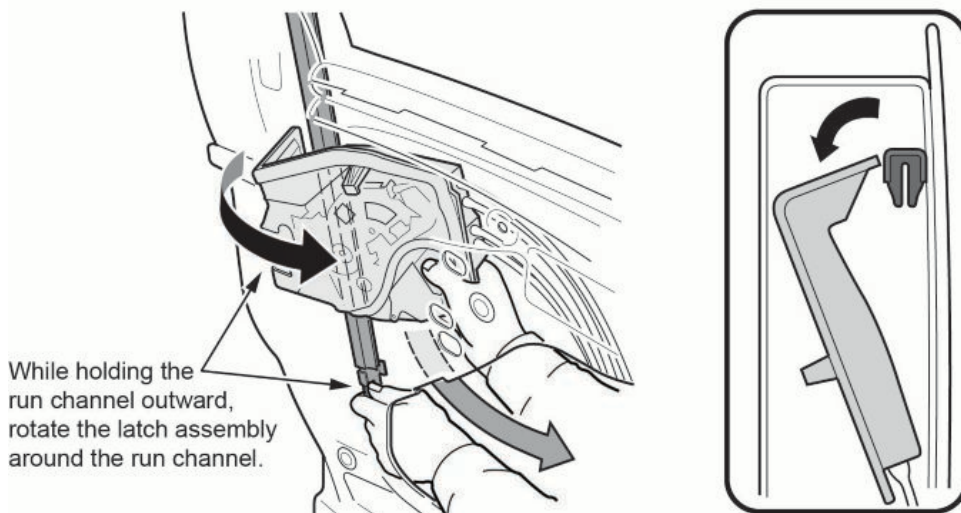
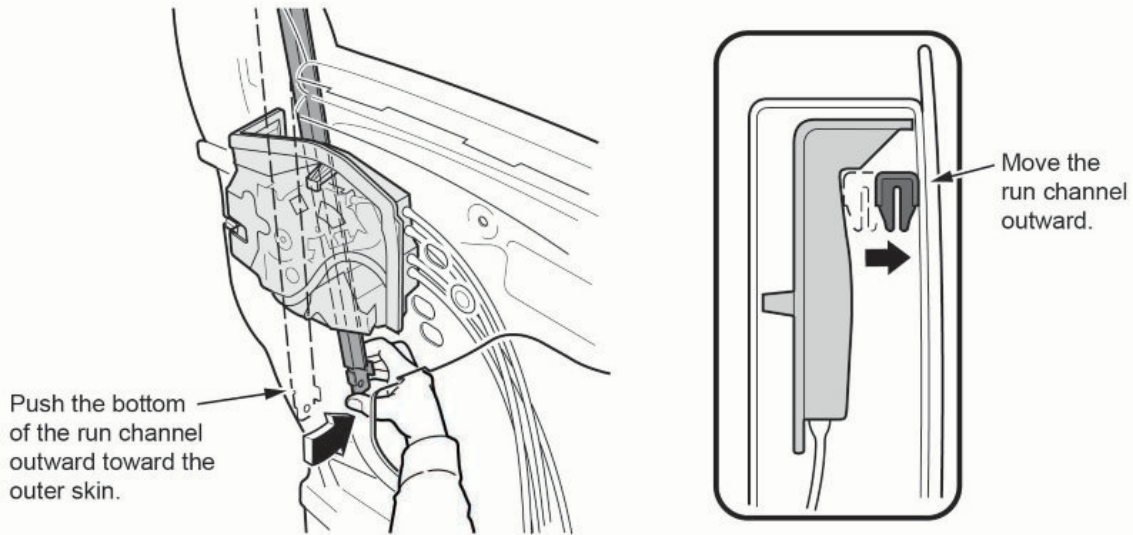
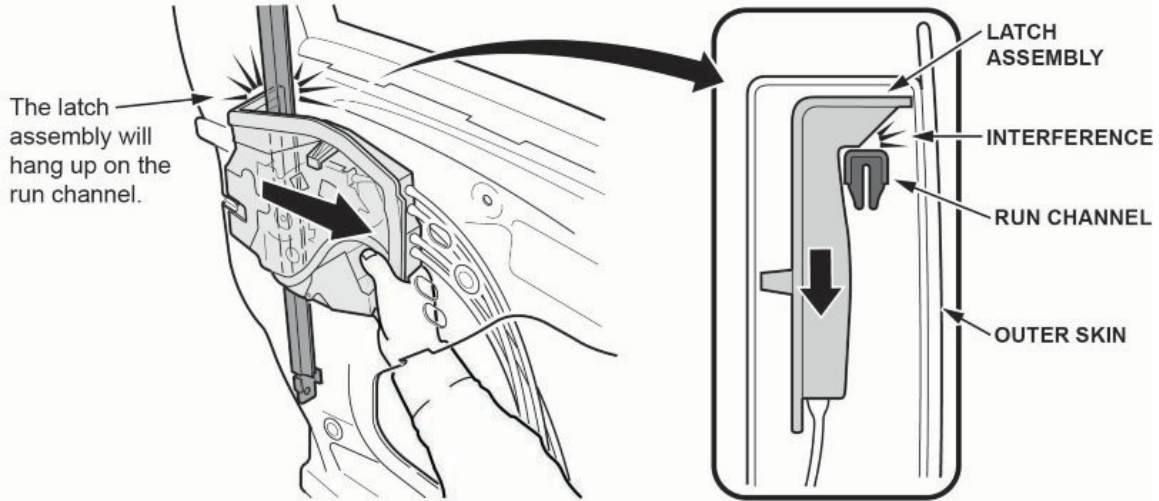

22. Once the latch is in the opening, disconnect the connectors, then remove the latch.

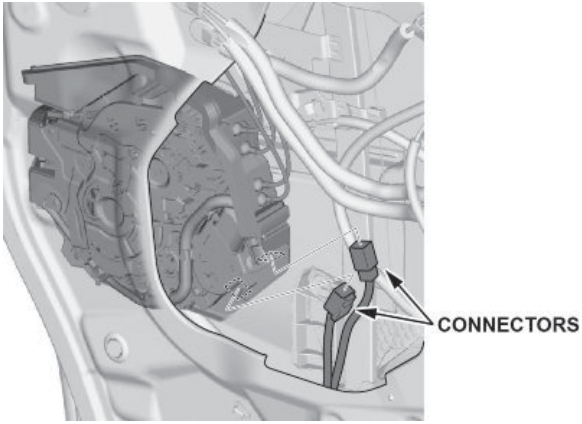

23. Place the new latch in the opening, and connect the connectors.

24. While pushing the bottom of the sliding door rear run channel outward, push the new latch rearward, rotating it around and behind the run channel, lining up the latch mechanism with the latch opening in the door skin.

**NOTE**

The latch cannot be inserted past the sliding door rear run channel if the latch is inserted below this position.

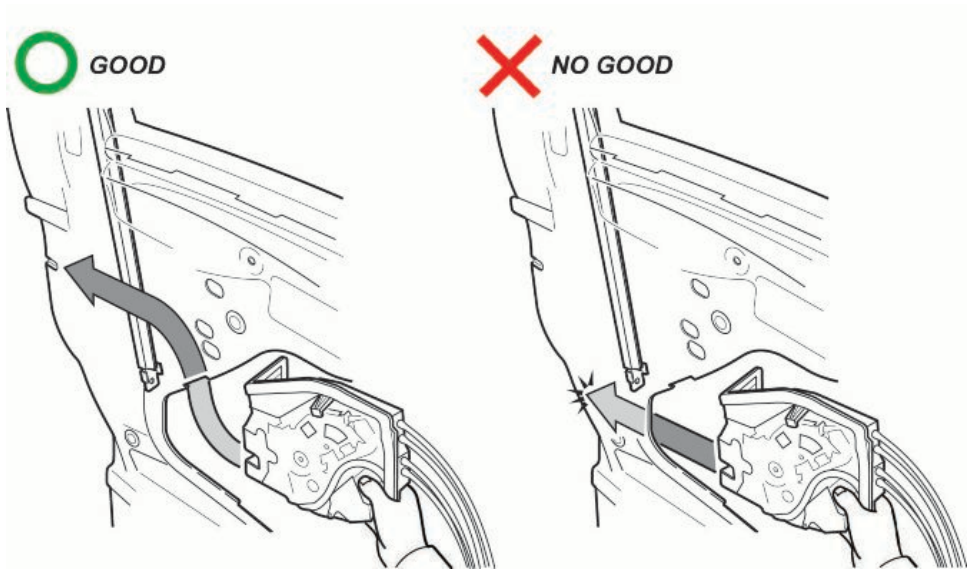

25. Install and torque the four rear latch fastener bolts to **5.4 N·m (4 lb-ft)**, and install the clip.

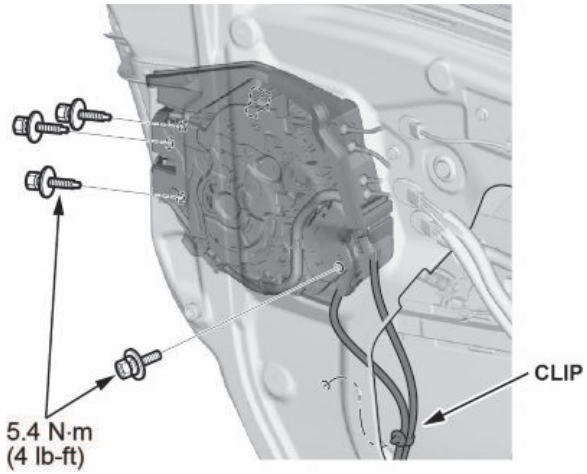

26. **Install the reset cable as shown.**

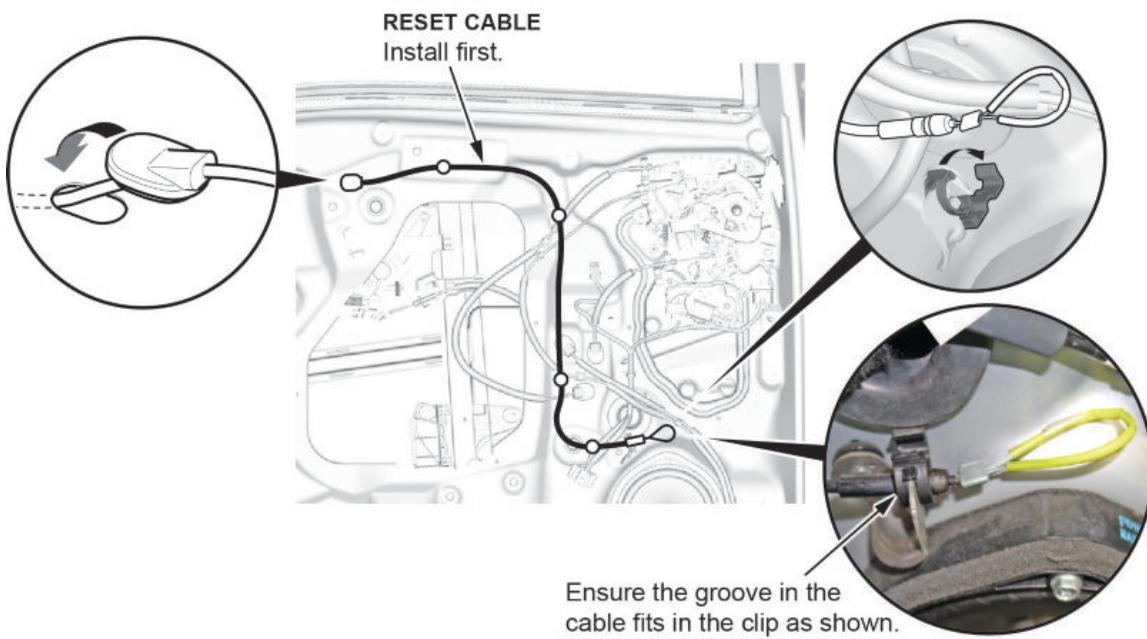

27. Install the cables.

27.1. Install the rear latch cable.

27.2. Install the failsafe cable. Make sure the cable is installed in groove and not between the front rib and the rubber boot.

**NOTES**

- Install the end of the cable before installing the cable into the cable fastener.
- Make sure the cable is not kinked or bent.

27.3. Install the power release cable.

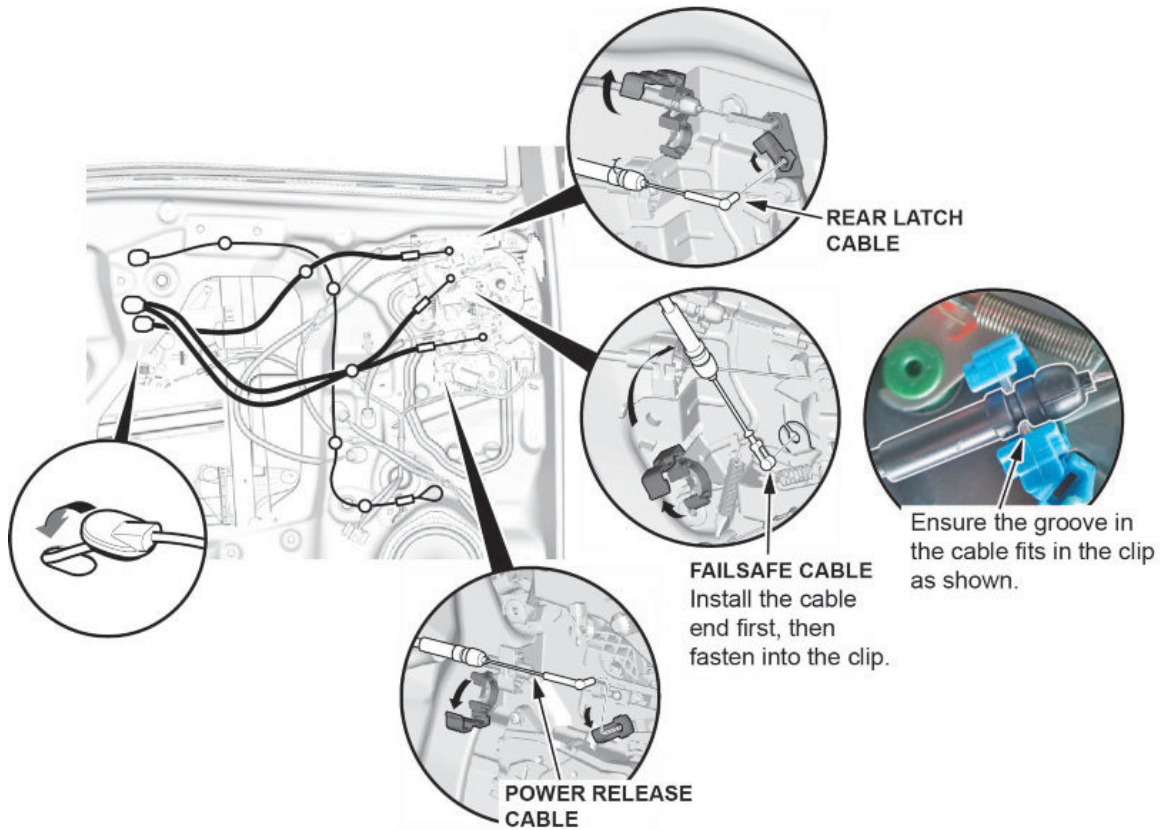

28. Install the remaining removed parts in the reverse order of removal, tightening all fasteners to the specified torque.
29. Repeat steps 5 thru 28 to replace the rear latch on the opposite door.
30. Remove the rear fuse box access panel. Check if fuses F2, F7, F14, and F19 are installed.
  - If the fuses are installed, go to step 32.
  - If the fuses are not installed, go to step 31.

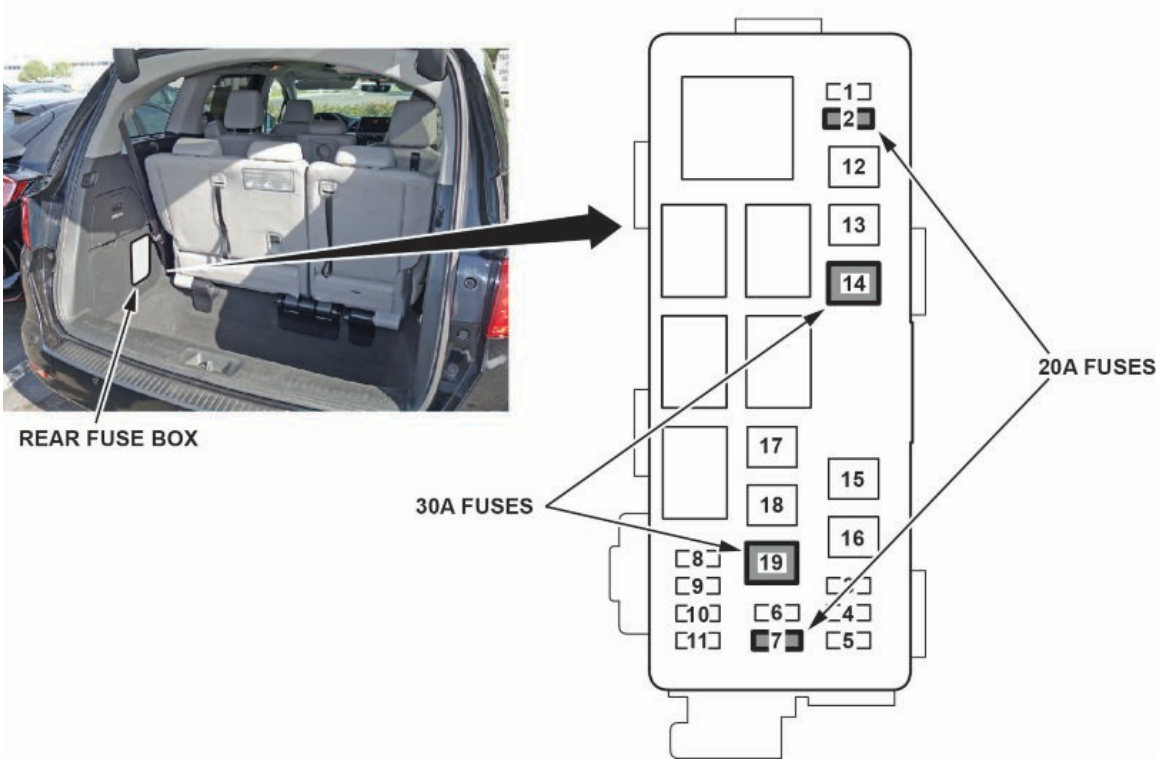

31. The power sliding door was disabled to prevent it from opening unexpectedly by removing 4 fuses and disconnecting the main switch connector. To enable the power sliding door do the following:

31.1. The fuses should be taped to the inside of the fuse box panel. Remove the fuses from the tape and install the 20 amp fuses into the F2 and F7 locations, then install the 30 amp fuses in locations F14 and F19.

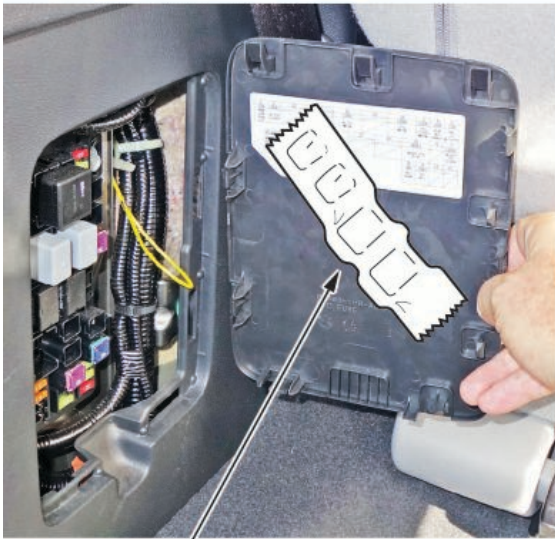

REMOVED FUSES TAPED TO THE INSIDE OF THE REAR FUSE BOX PANEL

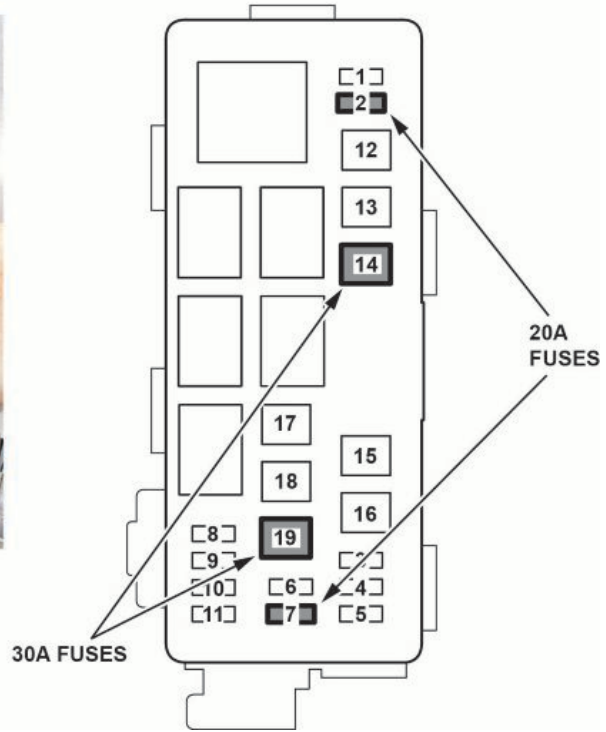

31.2. Remove the driver's dashboard side cover.

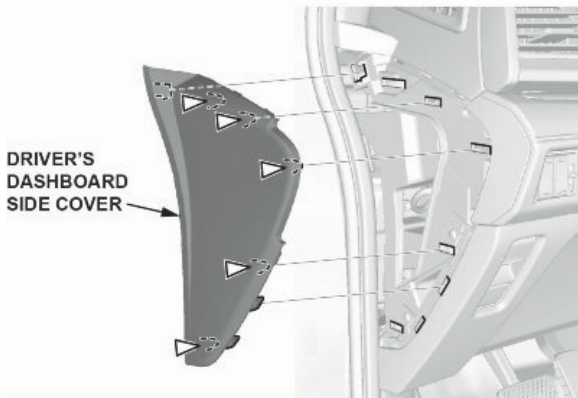



31.3. Remove the driver's dashboard lower cover.

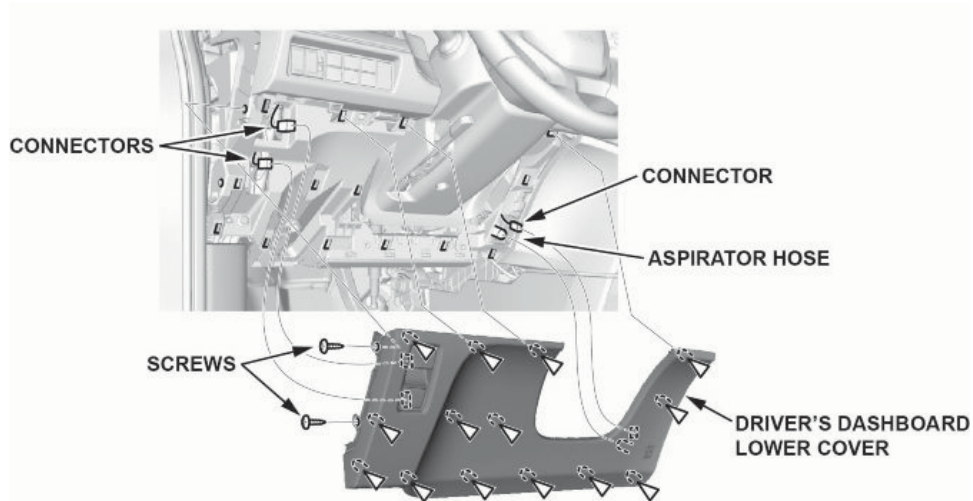

31.4. Cut the zip tie, and connect the power sliding door main switch connector.

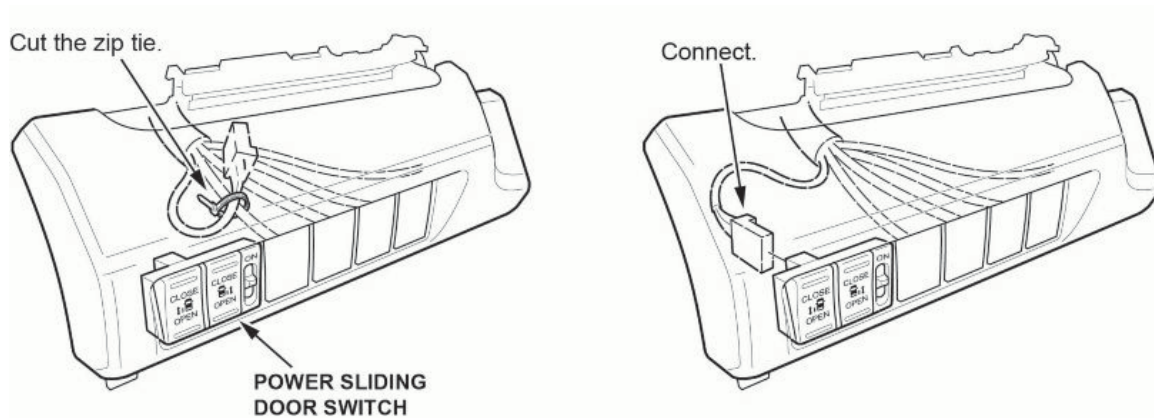

31.5. Install the driver's dashboard side cover and the driver's dashboard lower cover.

32. Connect the battery, and turn the power sliding door main power to ON. Confirm the latches work properly by using the power door feature to open and close both power sliding doors.

**NOTES**

If the rear latch does not work properly, check the following:

- Confirm the cables are routed properly, and that the cable ends at the fasteners are properly installed. If the cables are not routed properly and not installed at the fasteners properly, the rear latches may not close properly.
- Do a battery cable reset to reset the power sliding door control unit.

33. Install the second row outer seats.

33.1. Insert the front seat hooks into the front floor strikers.

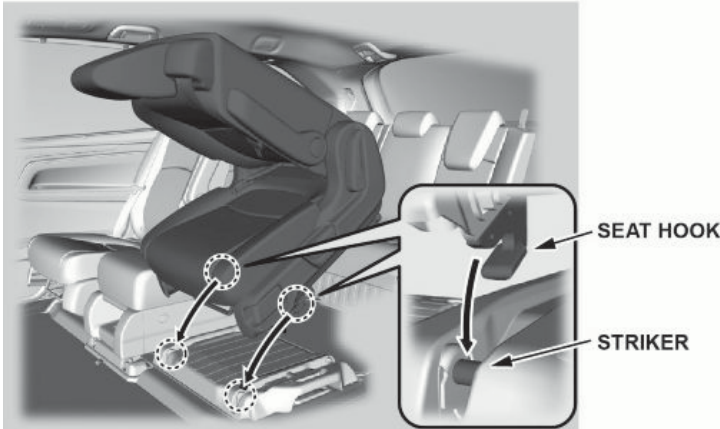

33.2. After confirming both front hooks are fully inserted into the front strikers, begin to lower the seat then allow it to drop and lock to the rear strikers.

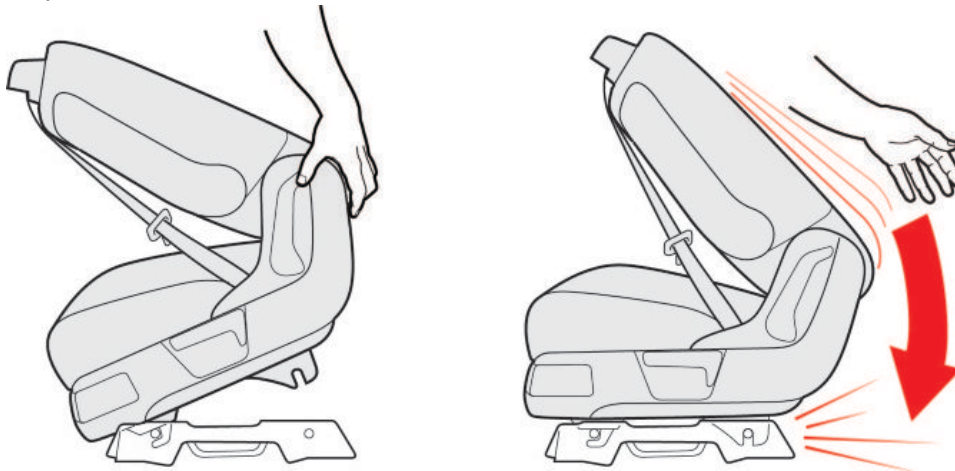

33.3. Raise the seat-back to an upright position, then rock the seat back and forth to confirm both the inner and outer latches are securely locked into position.

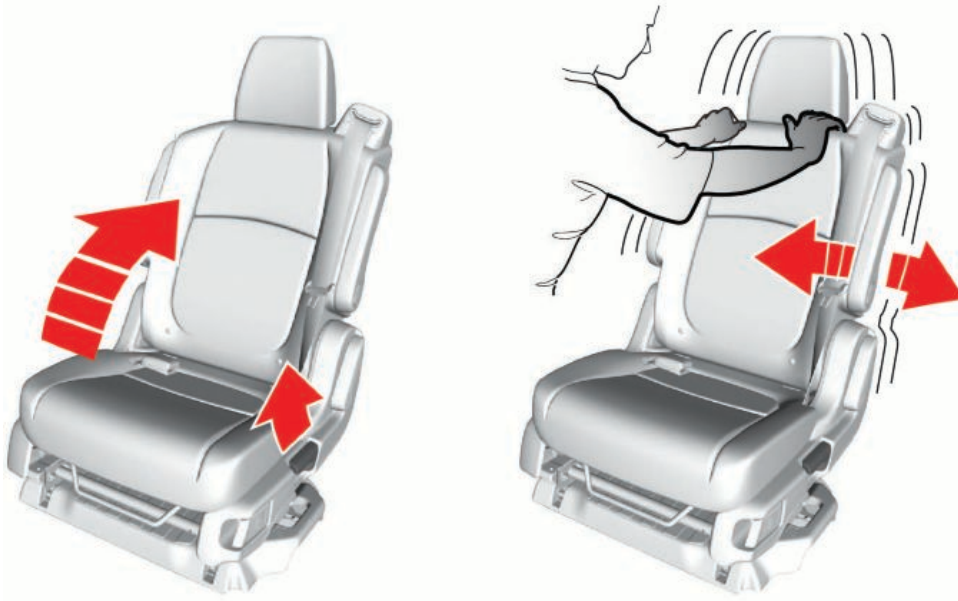

END