



# Alternator Cable Routing Vision With Ford Engine

# RECALL

Models Affected: Certain 2017-2019 Visions with Ford 6.8L Engines

ISSUE	CORRECTIVE ACTION
<p>On certain 2017-2019 Visions with Ford 6.8L engines the alternator cables may not be routed correctly. The alternator cables may contact and potentially chafe against the air conditioning support bracket “if equipped”, and the DCM-to-Toe Box reinforcement channel.</p>	<p>Inspect for proper clearance between the alternator cables and the air conditioning support bracket “if equipped”, and the DCM-to-Toe Box reinforcement channel. If required correct routing, per instructions provided below.</p>

## PROCEDURE

**WARNING:** Always follow all Federal, State, Local and Shop safety standards and use proper safety equipment, and thoroughly read and understand all instructions before performing these procedures.

### INSPECTION PROCEDURE

1. Park bus on a level surface, apply parking brake, remove ignition key, and chock wheels.
2. Disconnect Batteries: Note when disconnecting the batteries, remove negative cable first.
3. Inspect alternator cable routing per the illustrations on Pages 2 and 3. Insure that alternator cable and bracket for A/C option “if equipped” is oriented as shown on Page 2. Insure no contact with the alternator cables.
4. As a general guide maintain approximately ½ inch clearance gap between alternator cable and bracket for A/C option “if equipped”, and the DCM-to-Toe Box reinforcement channel.

### ALTERNATOR CABLE ORENTATION CORRECTION

5. If alternator cable orientation on positive stud requires correction, loosen the stud nut, reorient cable per “RIGHT WAY” illustration Page 2, and torque stud nut to 11-15 ft. lbs.

### A/C BRACKET ORENTATION CORRECTION

6. If bracket for A/C option orientation requires correction, loosen the attaching nut, reorient bracket per “RIGHT WAY” illustration Page 2, and torque attaching nut to 5-7 ft. lbs.
7. If reorientation in either step 5 or step 6 was required, inspect for any possible damage to the alternator cable. **If any damage is present, contact your local Blue Bird Dealer for replacement alternator cable.**
8. Reconnect batteries by connecting the negative cable last. Return bus to service.

RECALL CAMPAIGN R18Z0



# Alternator Cable Routing Vision With Ford Engine

# RECALL

R I 8 Z O  
- R E C A L L C A M P A I G N -

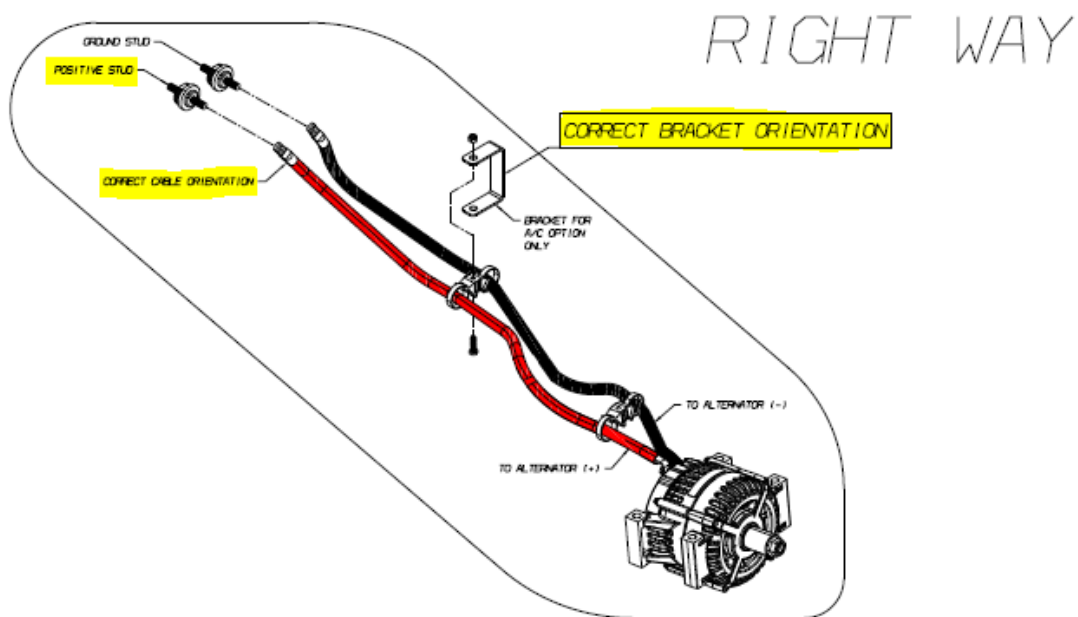
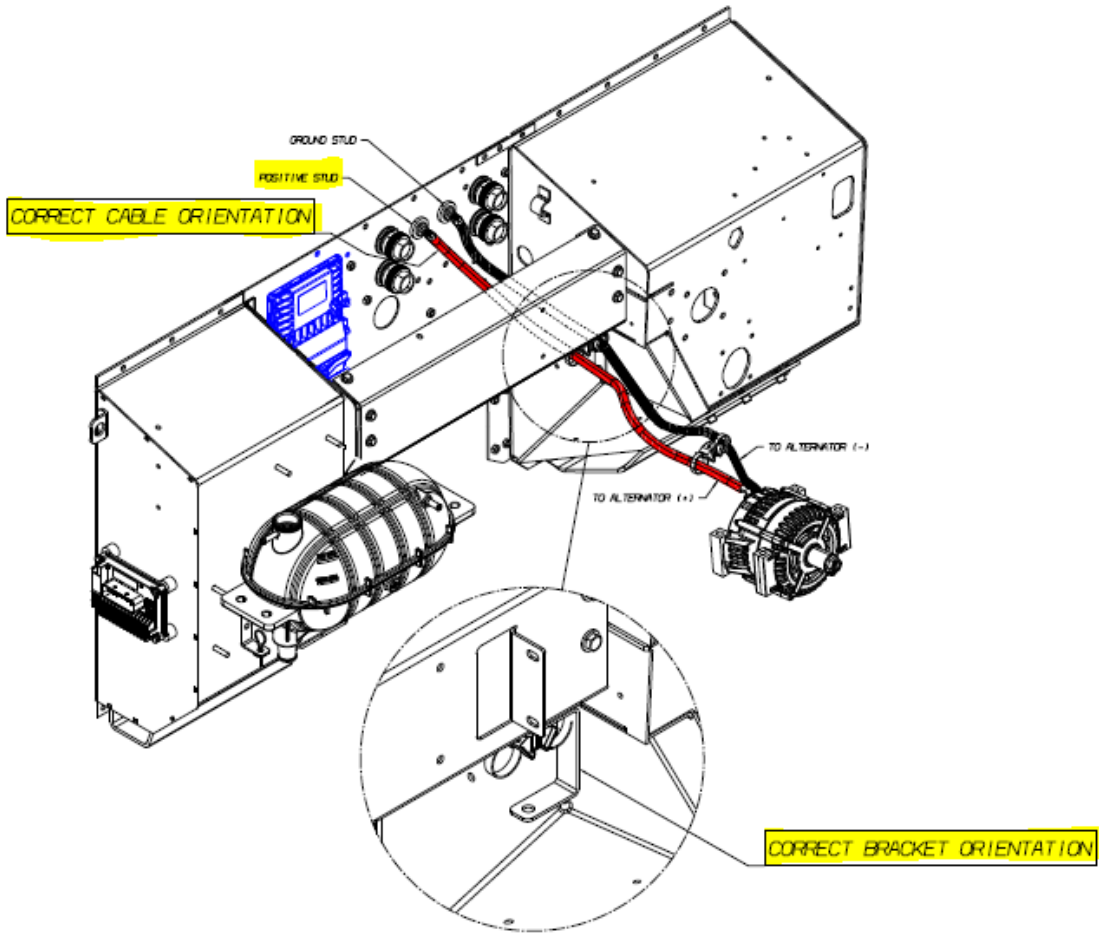



# Alternator Cable Routing Vision With Ford Engine

# RECALL

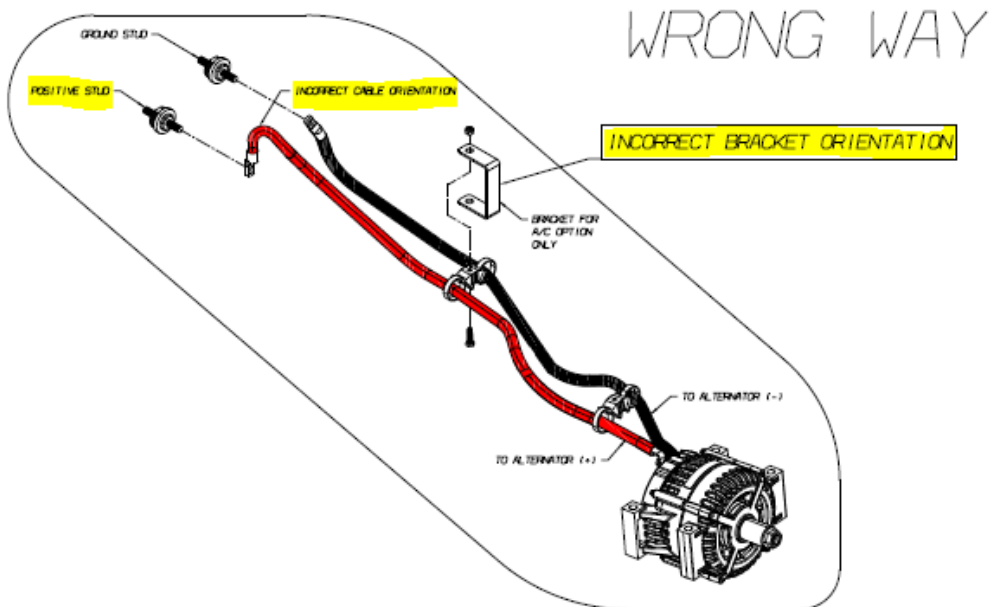
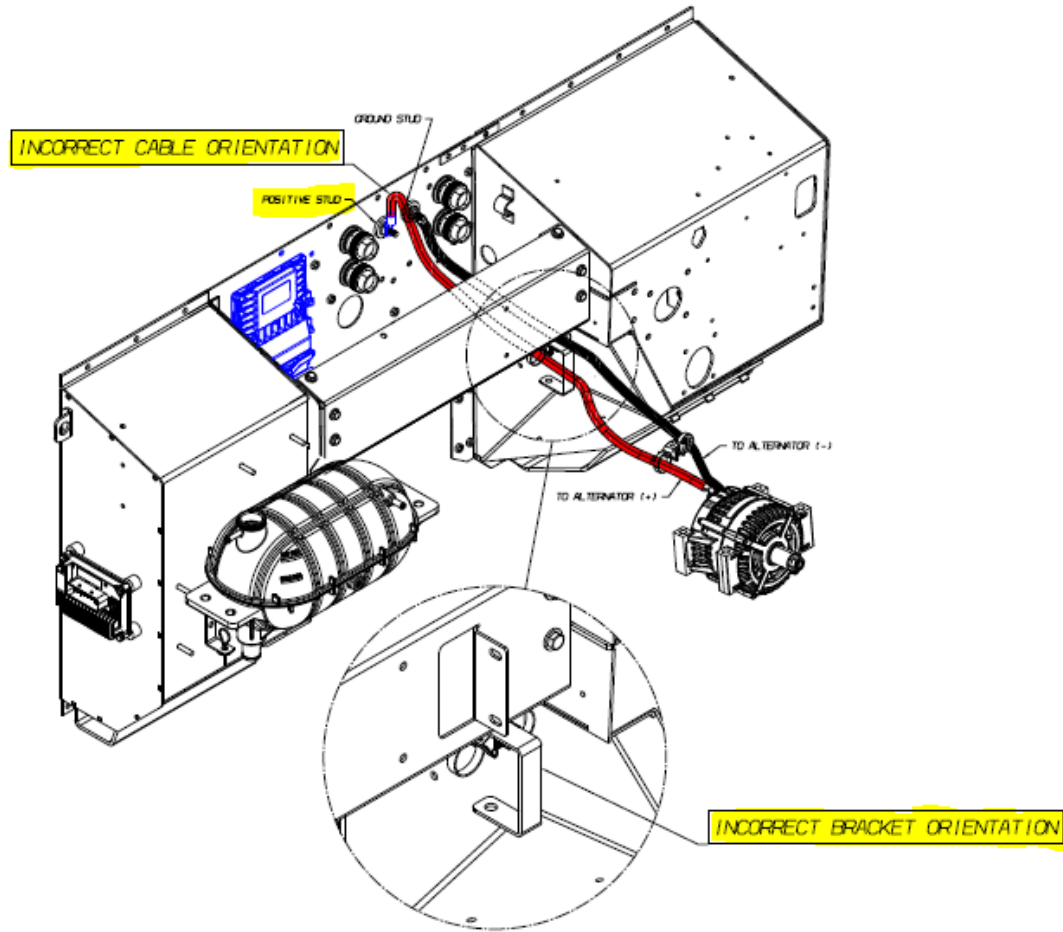

R 1 8 Z 0

RECALL CAMPAIGN