

2. REMOVE CAMSHAFTS

a) Remove the 2 camshafts.

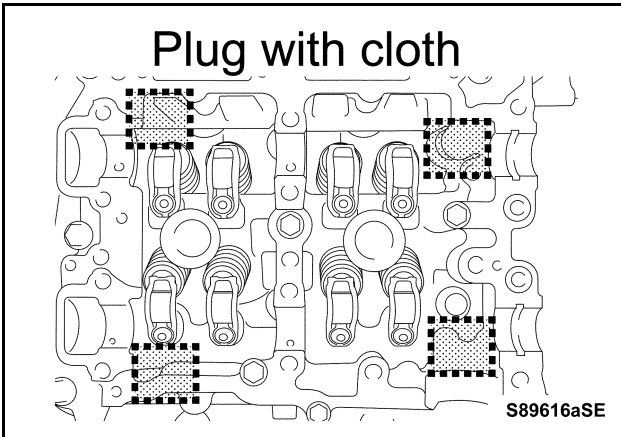

b) Plug the 4 oil holes with cloth to prevent any parts from dropping into them.

XVII. REPLACEMENT OF VALVE SPRINGS

[IMPORTANT] 6 TIPS TO PREVENT WORK ERRORS

1. PREPARE PARTS TRAY FOR STORING VALVE ROCKER ARM SUB-ASSEMBLIES AND VALVE ADJUSTING SHIMS IN ORDER

- a) All rocker arms and adjusting shims must be restored to their original locations. If not, the valve clearances may be disturbed and result in engine malfunctions. Be sure to store the removed components in order as shown, so that they can be restored to their exact original locations.

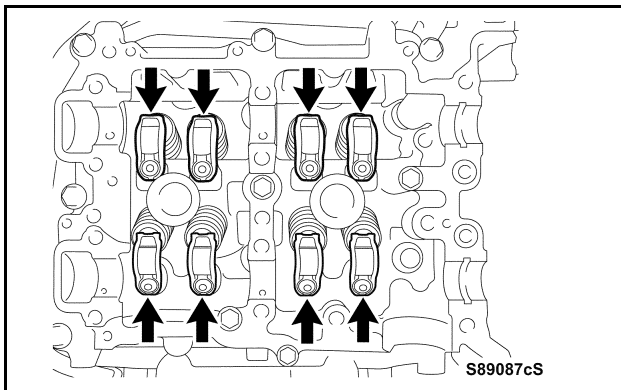
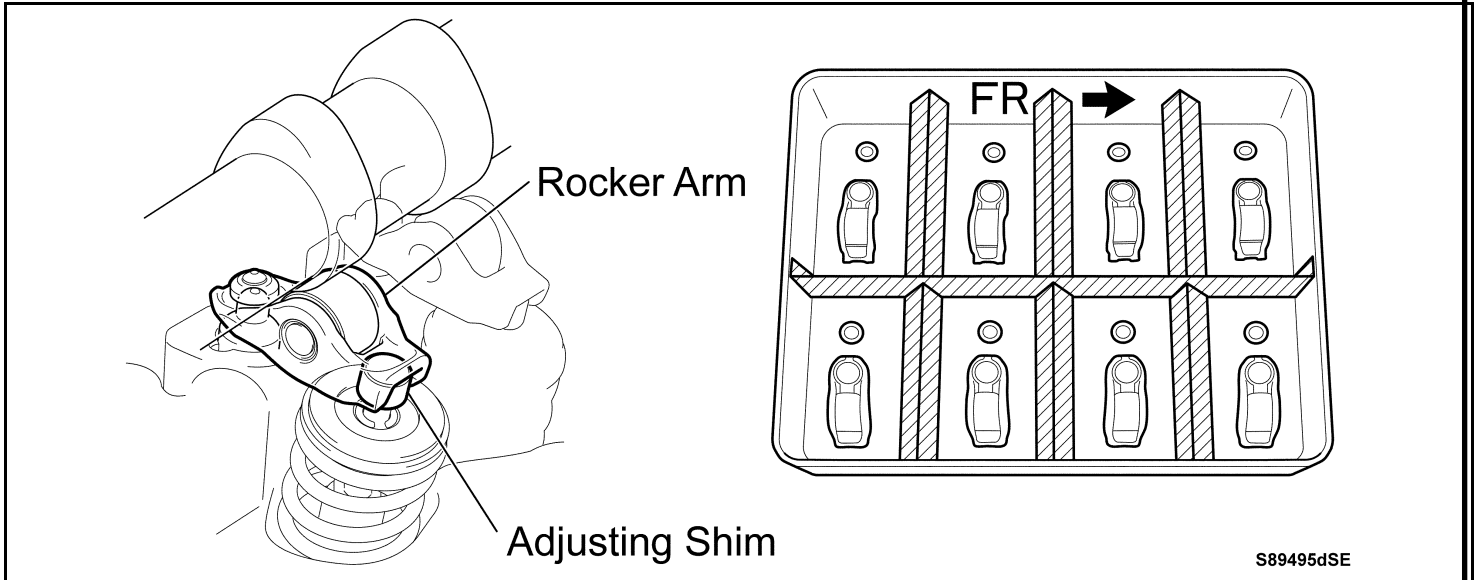

2. REMOVE NO. 1 VALVE ROCKER ARM SUB-ASSEMBLIES

- a) Remove and store the 8 valve rocker arms in the prepared parts tray in order, so that they can be restored to their original locations.

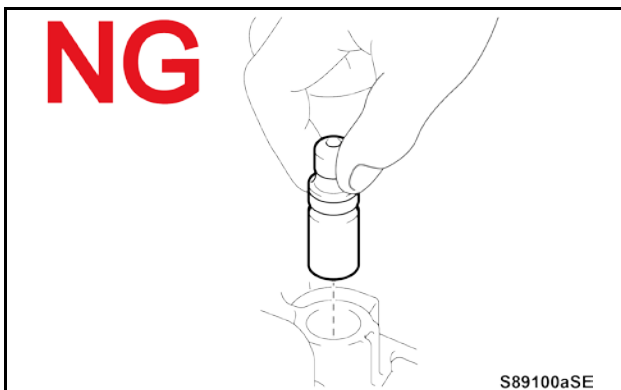

DO NOT remove the rocker arm pivot, or poor sliding performance may occur due to adhesion of foreign matter.

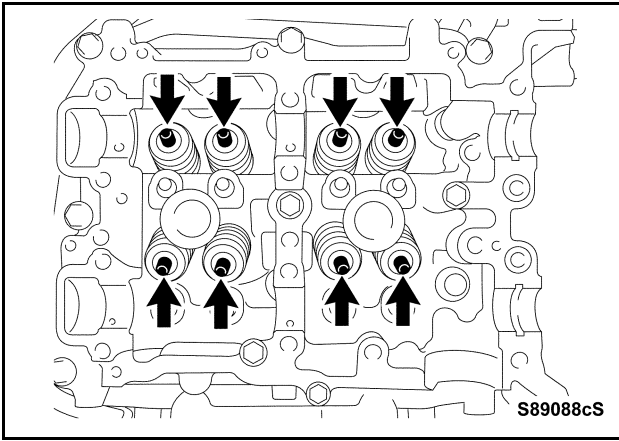

3. REMOVE VALVE ADJUSTING SHIMS

- a) Remove and store the 8 valve adjusting shims in the prepared parts tray in order, so that they can be restored to their original locations.

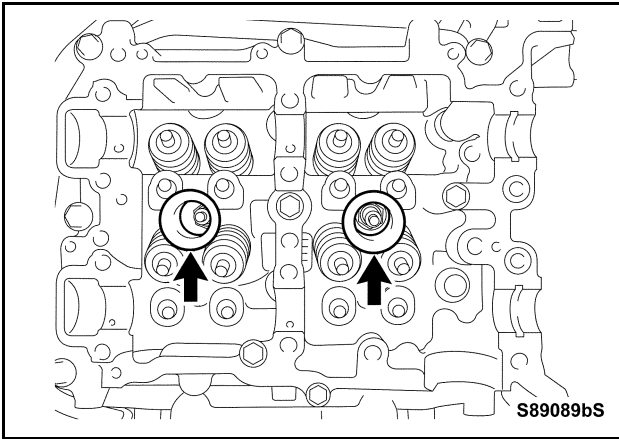

4. REMOVE SPARK PLUG TUBE GASKETS

- a) Remove the 2 gaskets.
- b) Destroy the removed 2 gaskets, and then store them in a separate container so as not to reinstall them in error.

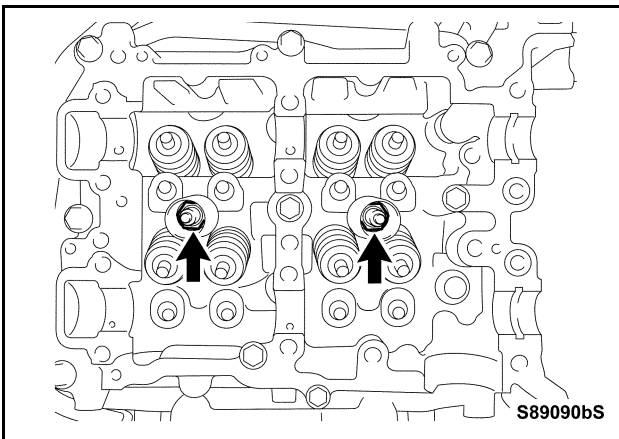

5. REMOVE SPARK PLUGS

- a) Using a 14 mm (0.55 in.) spark plug wrench, remove the 2 spark plugs.
- b) Store the removed 2 spark plugs in order in a separate parts tray, so that each can be restored to its original location.

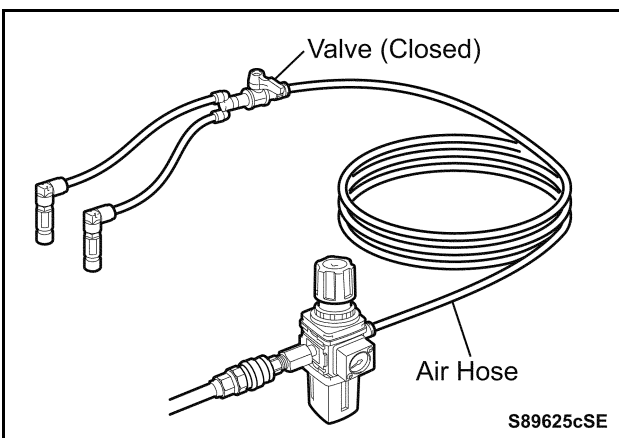

6. INSPECT AND CLEAN PRESSURE HOLDING TOOL

- a) Close the valve, and connect the compressed air line to the regulator.



DO NOT apply pneumatic pressure higher than 1.0 Mpa (145 psi) as damage to the regulator may result.

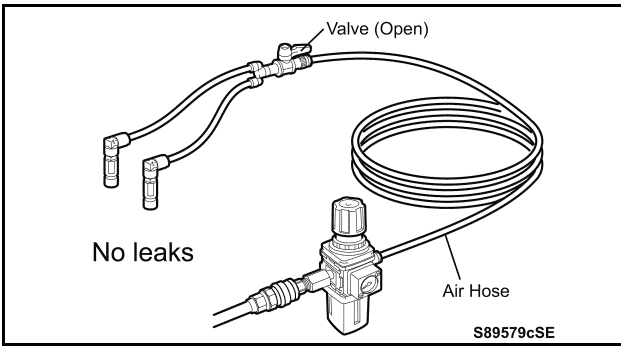

b) Open the valve, and check that there are no air leaks from any part.

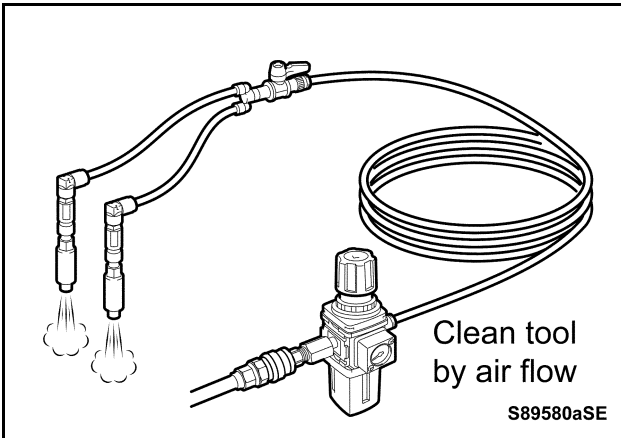

- c) Close the valve.
- d) Attach the 2 air adapters to the air hose.
- e) Open the valve to allow air to flow, and clean inside the air hose and the adapters.
- f) Remove the 2 air adapters.

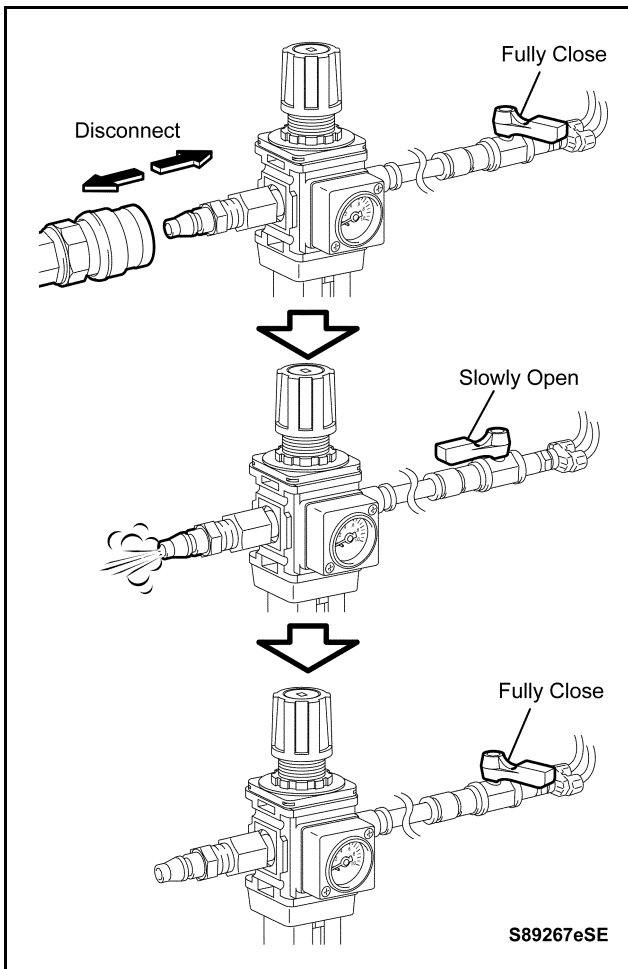

- g) Reset the air hose to the default condition.
 - 1) Close the valve.
 - 2) Disconnect the compressed air line from the regulator.
 - 3) Slowly open the valve to discharge all residual pressures.
 - 4) Close the valve.

CYLINDER NO. 2 VALVE SPRING REPLACEMENT

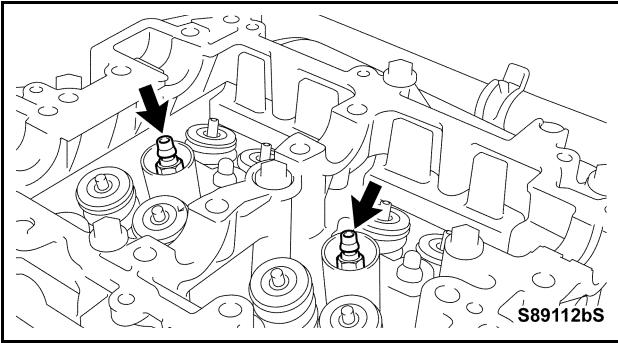

7. ATTACH AIR ADAPTERS

- a) Attach the 2 air adapters by hand.

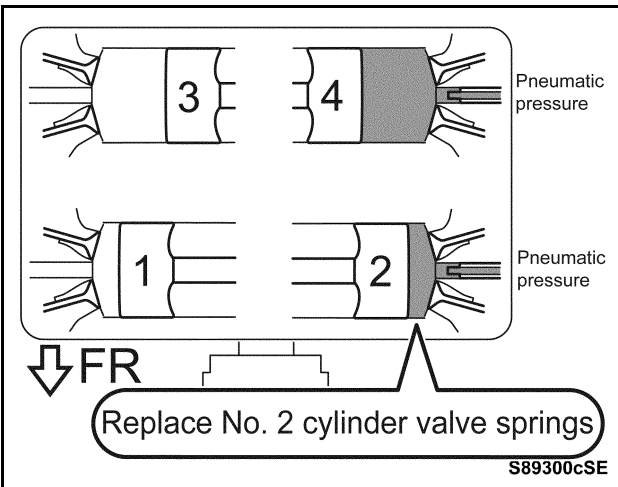

8. REPLACE NO. 2 CYLINDER VALVE SPRINGS

- a) Replace the No. 2 cylinder valve springs using the same removal procedure as for the No. 3 cylinder valve springs.



Before proceeding with the replacement procedure, be sure to carefully read over the instructions for replacement of No. 3 cylinder valve springs, to fully understand the necessary work procedure and the cautions.

- b) Slowly apply pneumatic pressure.

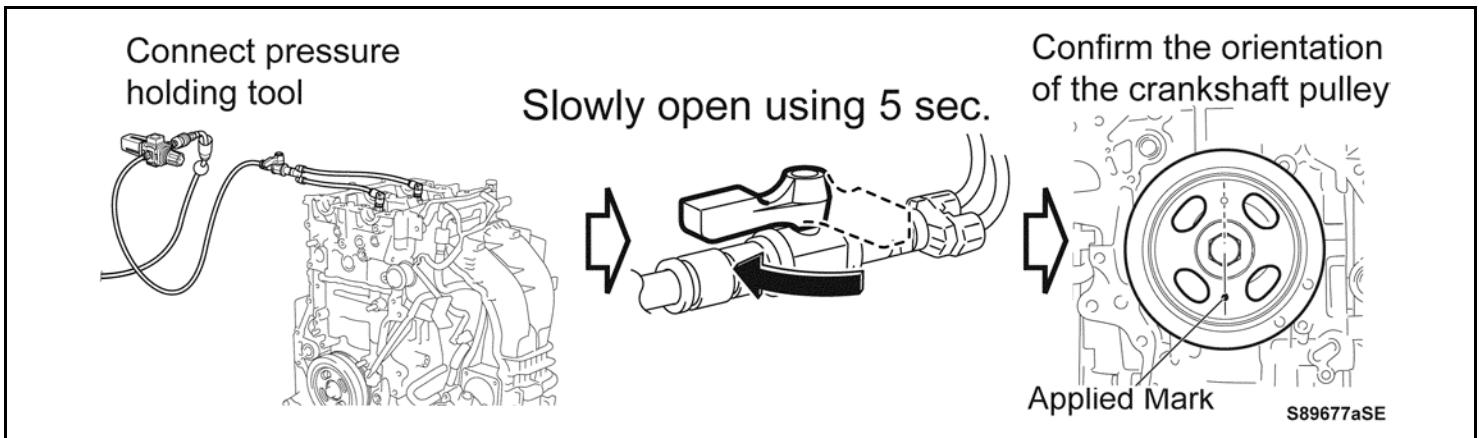

- c) Cover cylinder No. 4 with cloth.
- d) Confirm that the remover and the replacer are free of damage and contamination, and then wear protective glasses and protective gloves.
- e) Replace the No. 2 cylinder valve springs.
- f) Reset the pressure holding tool to the default condition (zero pressure).

CYLINDER NO. 4 VALVE SPRING REPLACEMENT

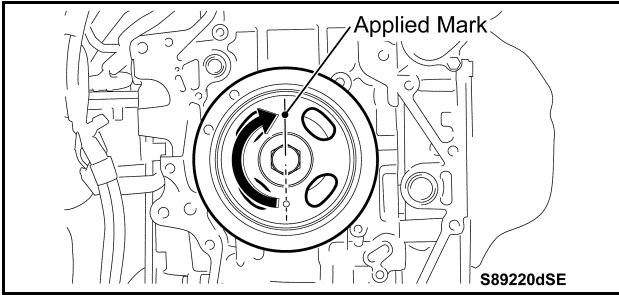

9. SET NO. 4 CYLINDER TO TDC

- Rotate the crankshaft 180 degrees clockwise until the mark on the pulley is at the top as shown in the illustration (at the right side, when the engine is installed to the vehicle).

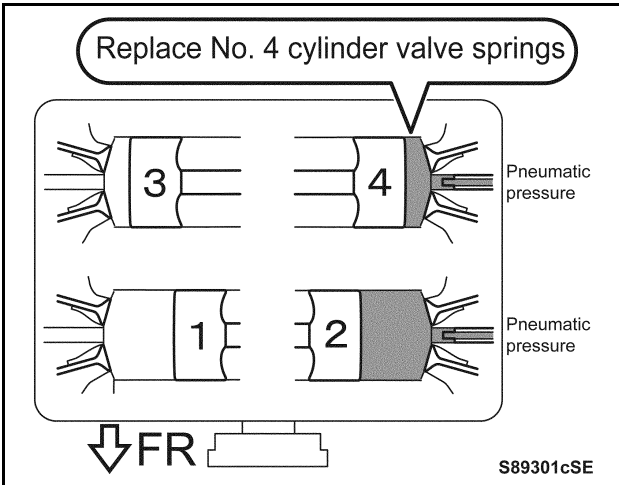

10. REPLACE NO. 4 CYLINDER VALVE SPRINGS

- Replace the No. 4 cylinder valve springs using the same removal procedure as for the No. 3 cylinder valve springs.



Before proceeding with the replacement procedure, be sure to carefully read over the instructions for replacement of No. 3 cylinder valve springs, to fully understand the necessary work procedure and the cautions.

- Slowly apply pneumatic pressure.

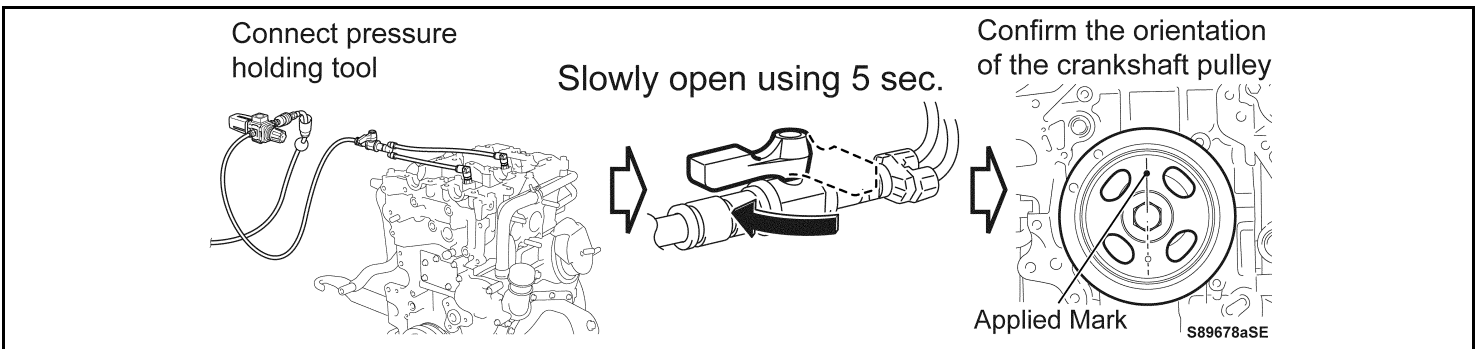

- Remove the cloth from cylinder No. 4, and then place it to cover cylinder No. 2.
- Confirm that the remover and the replacer are free of damage and contamination, and then wear protective glasses and protective gloves.
- Replace the cylinder No. 4 valve springs.
- Reset the pressure holding tool to the default condition (zero pressure).

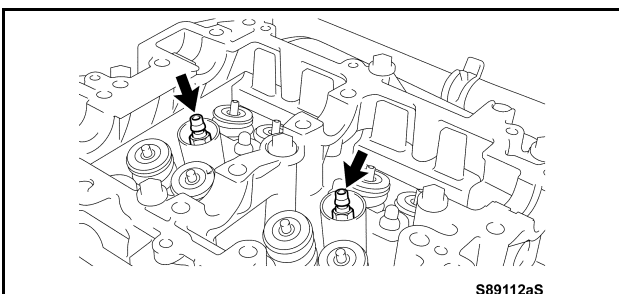

- Detach the 2 air adapters.

XVIII. REINSTALLATION OF CAMSHAFTS (LH BANK)

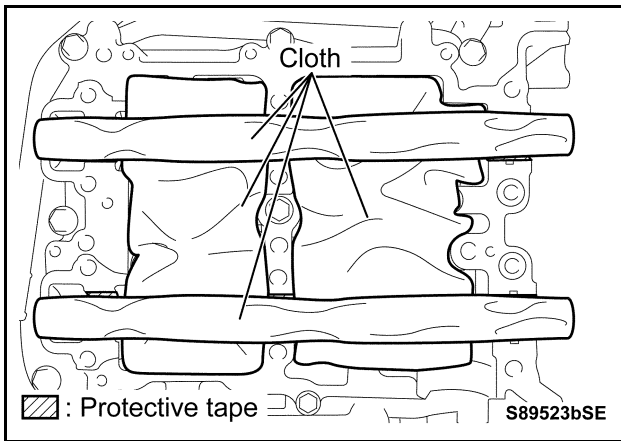

1. CLEAN AND DEGREASE COMPONENT INSTALLATION SURFACES

- Place pieces of cloth as shown to prevent any seal packing to enter inside the cylinder head.
- Place pieces of cloth to prevent dirt from entering the oil holes in the journal mating parts.
- Remove any old seal packing material.
- Degrease the seal packing adhesion surfaces.
- Remove the cloth.

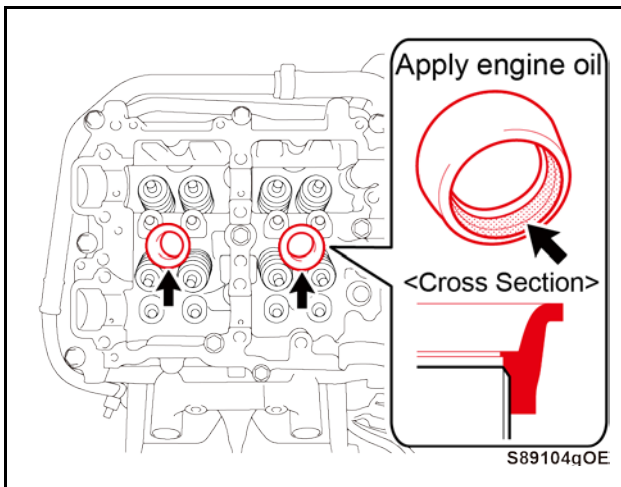

2. INSTALL SPARK PLUG TUBE GASKETS

- Apply a thin coat of engine oil to 2 **NEW** gaskets in the specified portions.
- Place the 2 **NEW** gaskets in the orientation as shown, and press them in as far as they can go by hand.

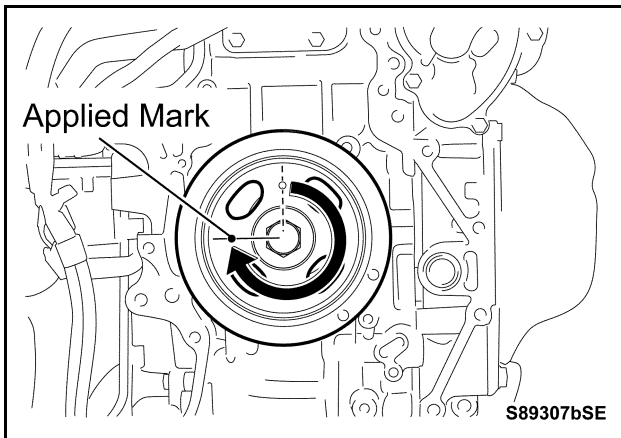

3. ALIGN HEIGHTS OF ALL PISTONS

- Rotate the crankshaft 270 degrees clockwise until the mark on the pulley is at the left side as shown in the illustration (at the top, when the engine is installed to the vehicle).



Adjust all pistons to the same height (no piston should be at or near the TDC position) to prevent problems upon reinstallation of the camshaft.

[IMPORTANT] 6 TIPS TO PREVENT WORK ERRORS

The valve clearances are controlled by the valve rocker arms and the valve adjusting shims.
The removed components must be restored to their original locations.
If not, the valve clearances may be disturbed and result in engine malfunctions.

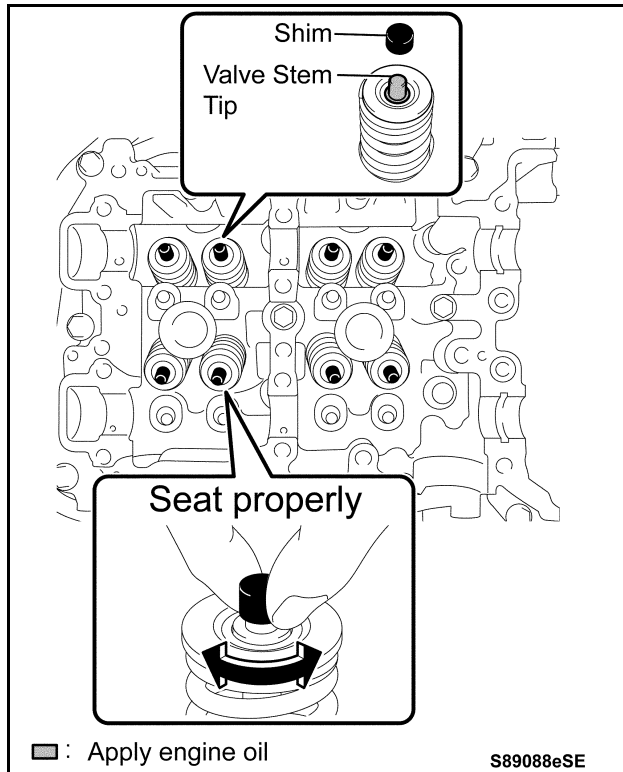

1. REINSTALL VALVE ADJUSTING SHIMS

- Apply engine oil to the tip of the valve stems.
- Reinstall the 8 adjusting shims to their original locations.
- Rotate the 8 adjusting shims to seat them properly.



Be sure to rotate the adjusting shims to seat them properly, or they may lift and fall.

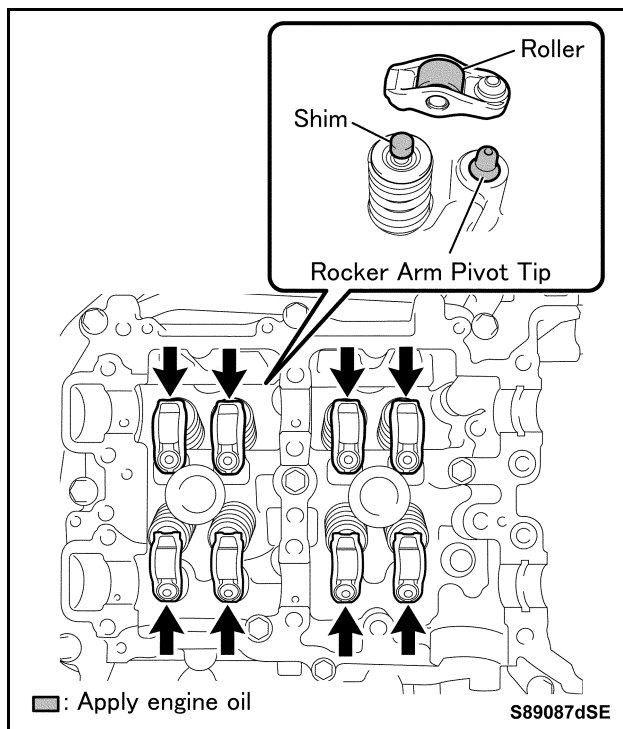

2. REINSTALL NO. 1 VALVE ROCKER ARM SUB-ASSEMBLIES

- Apply engine oil to the tips of the rocker arm pivots and the upper surfaces of the adjusting shims.
- Reinstall the 8 rocker arms to their original locations.

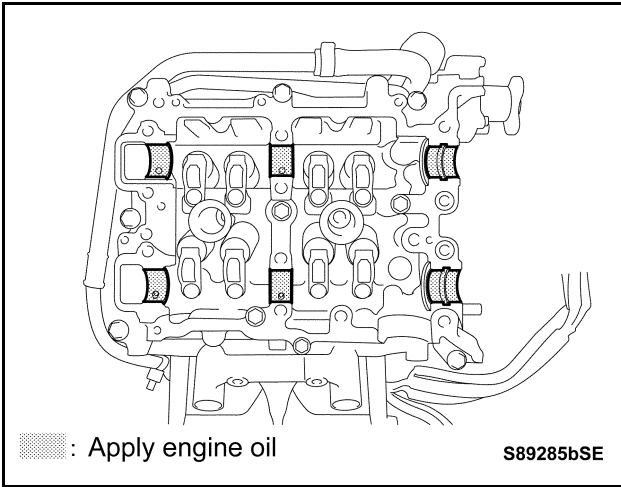

3. REINSTALL CAMSHAFTS (for LH Bank)

- a) Apply engine oil to the camshaft housing bearings.



STOP

Confirm that the bearings are free of adhesion of foreign materials or dirt.

- b) Set the 2 camshafts on the camshaft housing.

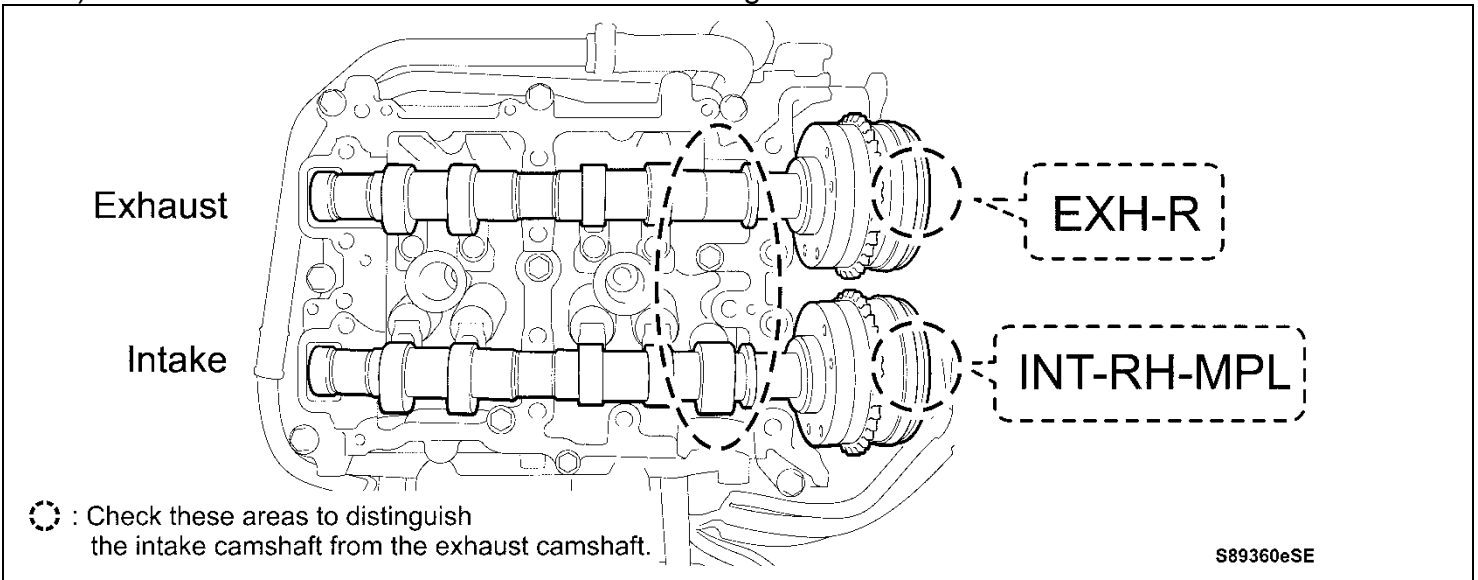

【LH Bank】

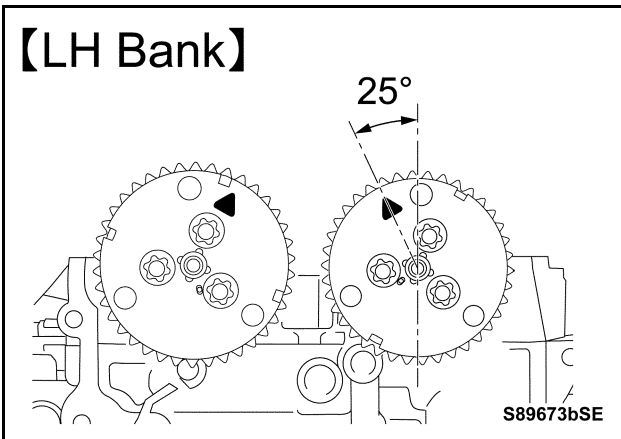

- c) Set both camshafts to the zero lift positions as shown (set them in positions where they are not lifted by rotating the shafts).

4. REINSTALL CAMSHAFT CAPS (for LH Bank)



- Seal packing needs to be applied to the front and rear camshaft caps for bonding.
- Each component must be attached within 5 minutes of seal packing application, and all bolts must be tightened to the specified torque within 15 minutes of the application.
- The bolts of the 5 camshaft caps (front, rear and center camshaft caps) must be handled as a set, and tightened uniformly and gradually in the specified order in several passes. Work efficiently and carry out the work as instructed below to have all the bolts tightened within 15 minutes.

- a) Clean and degrease the 5 camshaft caps.
- b) Apply a thin coat of engine oil to the 5 camshaft caps on the journal contact surfaces.



DO NOT excessively apply engine oil and allow it to condense, or the engine oil may adhere to the seal packing adhesion surfaces and result in insufficient sealing.

Clean and degrease

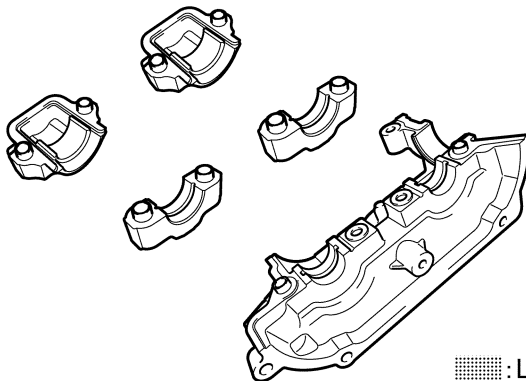

Apply engine oil

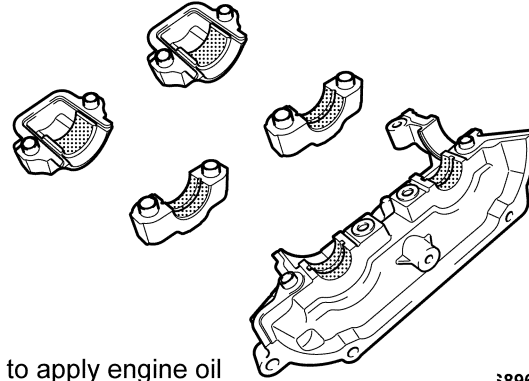

▒ : Locations to apply engine oil

389618bSE

- c) Remove the seal packing, which has got hard, from the tip of the sealer gun.
- d) Apply seal packing to the front camshaft cap.



- **DO NOT** apply excessive seal packing to the thin (ϕ 1.5 to 2.5 mm (0.1 to 0.16 in.)) seal packing application areas close to the bearings, or the engine seizure may occur.
- Each component must be attached within 5 minutes of seal packing application, and all bolts must be tightened to the specified torque within 15 minutes of the application.

There are 5 thick seal packing application areas and 4 thin seal packing application areas.

DO NOT leave any area without application of the seal packing.

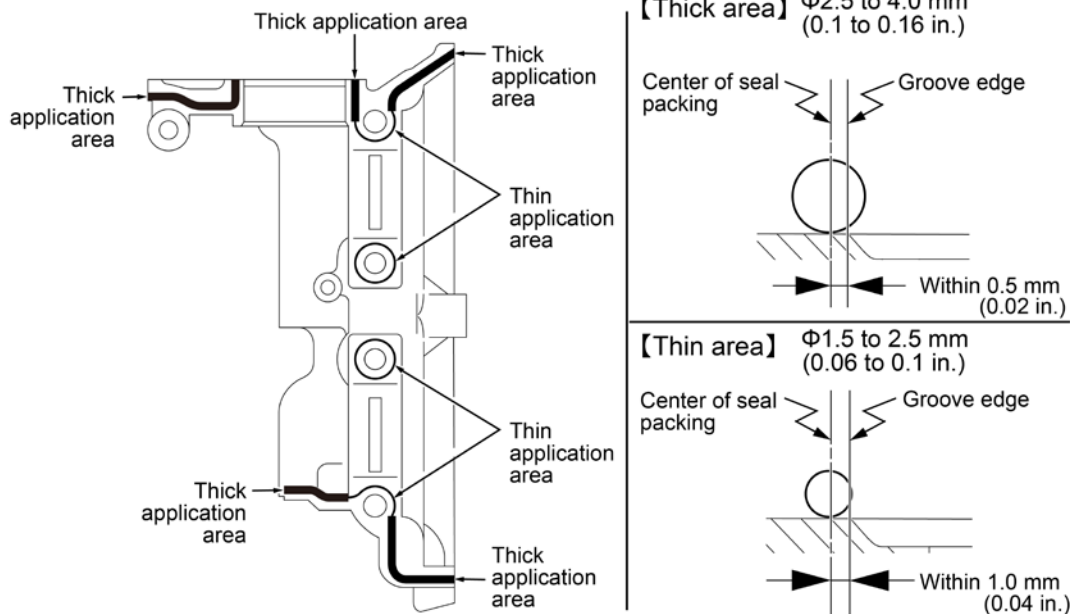

DO NOT skip applying seal packing onto the thin application area.

S89211fSE

Temporarily tighten

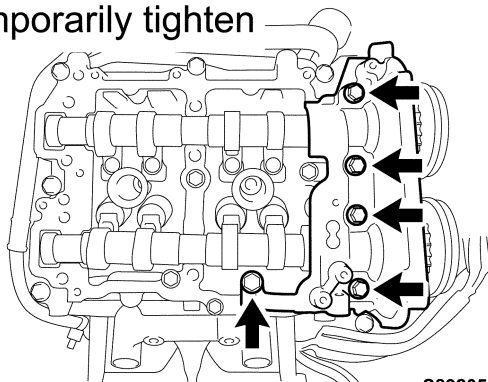

S89205bSE

- e) Before temporarily reinstalling the front camshaft cap, make a final confirmation that the seal packing is applied in all necessary portions.
- f) Set the front camshaft cap, and temporarily reinstall it with the 5 bolts.

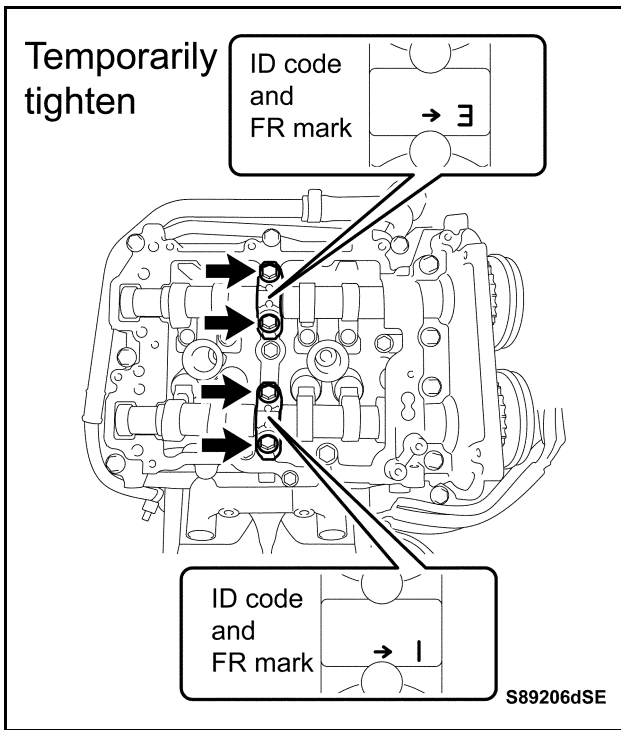

- g) Check the identification code and front mark on each center camshaft cap, set the 2 caps, and temporarily reinstall them with the 4 bolts.

- h) Remove the seal packing, which has got hard, from the tip of the sealer gun.
 i) Apply seal packing to the 2 rear camshaft caps.



- **DO NOT** apply excessive seal packing to the thin (ϕ 1.5 to 2.5 mm (0.06 to 0.1 in.)) seal packing application areas close to the bearings, or the engine seizure may occur.
- Each component must be attached within 5 minutes of seal packing application, and all bolts must be tightened to the specified torque within 15 minutes of the application.

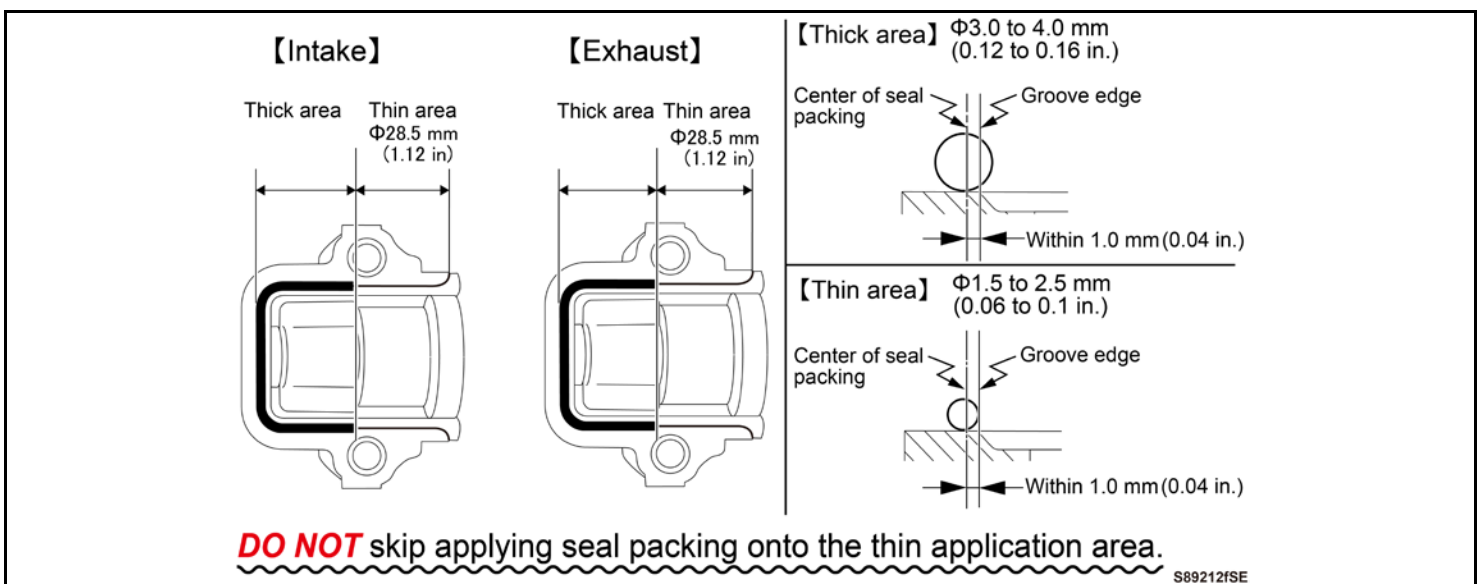

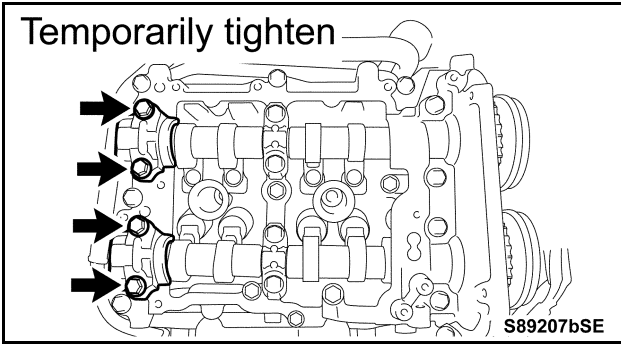

j) Set the 2 rear camshaft caps and then temporarily tighten the 4 bolts.

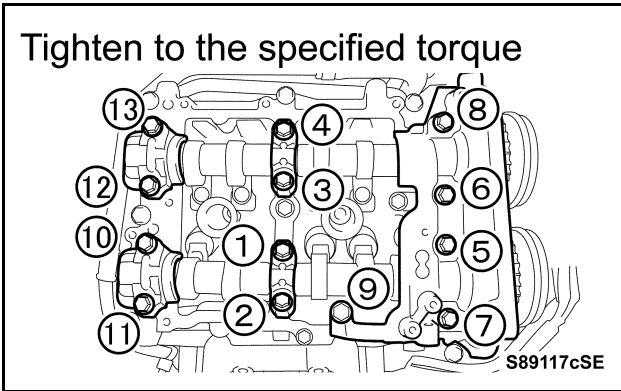

k) Uniformly and gradually tighten the 13 bolts in the specified order in several passes.

Specified torque:

13 ft.*lbf (18 N*m, 184 kgf*cm)

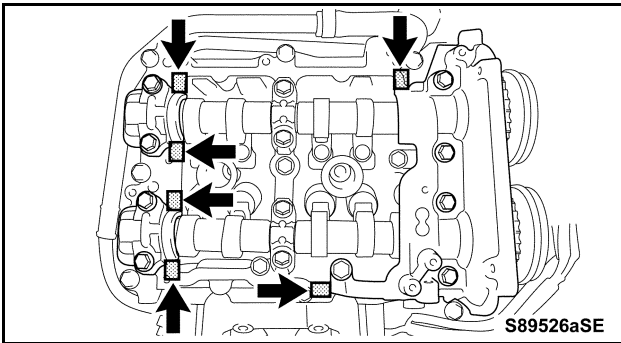

l) Completely remove any excess seal packing outside the camshaft caps.

STOP If any excess seal packing remains outside the camshaft caps, insufficient sealing of the cylinder head cover may result upon installation.

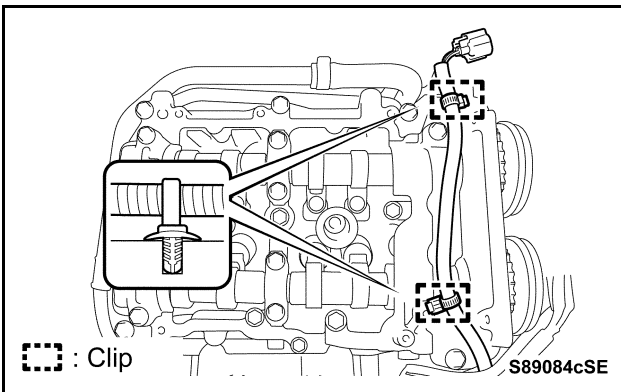

m) Attach the 2 clips (included in the Valve Spring Kit).

XIX. INSTALLATION OF CYLINDER HEAD COVER (LH BANK)

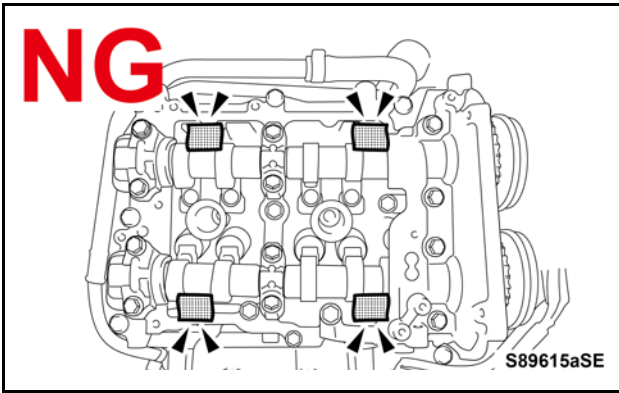

1. REINSTALL CYLINDER HEAD COVER SUB-ASSEMBLY LH

NOTE:

The cylinder head cover sub-assembly RH is sealed by combination of the rubber gasket and the seal packing.

- a) Make sure that all pieces of cloth have been removed from the cylinder heads.

- b) Clean the contact surfaces of the cylinder head cover sub-assembly and the mating part.

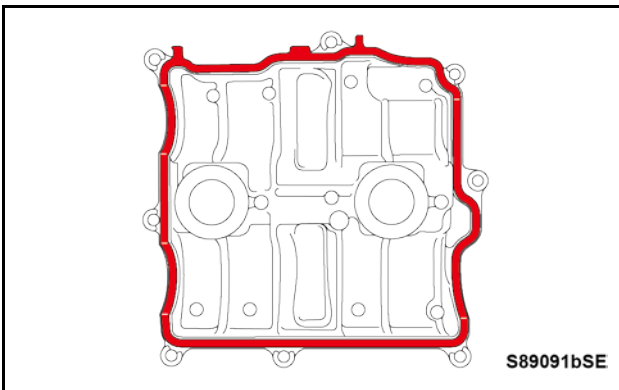
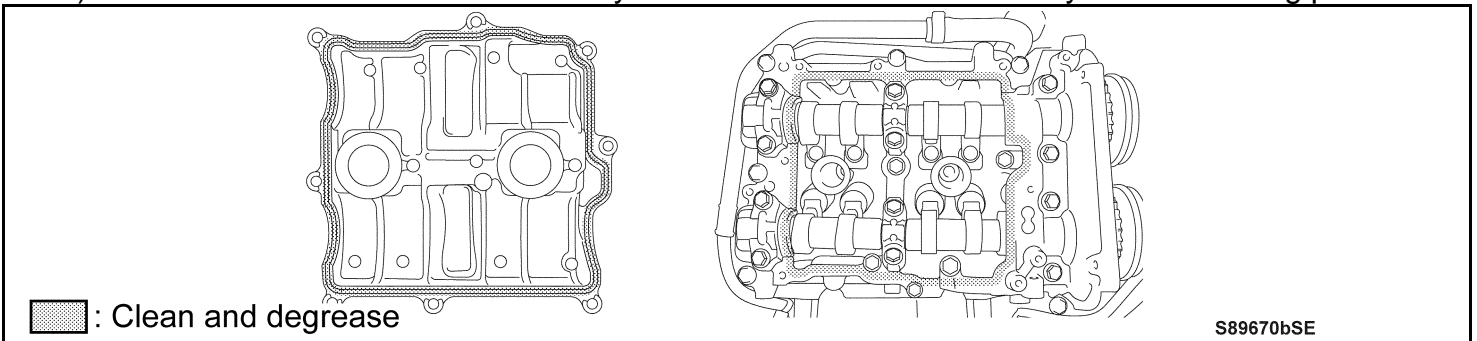

- c) Install a **NEW** rubber gasket.

- d) Remove the seal packing, which has got hard, from the tip of the sealer gun.
- e) Apply seal packing to the **NEW** rubber gasket in the specified locations.



- **DO NOT** apply seal packing to the areas other than specified (3 seal packing prohibited areas), or oil leaks may occur.
- Each component must be attached within 5 minutes of seal packing application, and all bolts must be tightened to the specified torque within 15 minutes of the application.

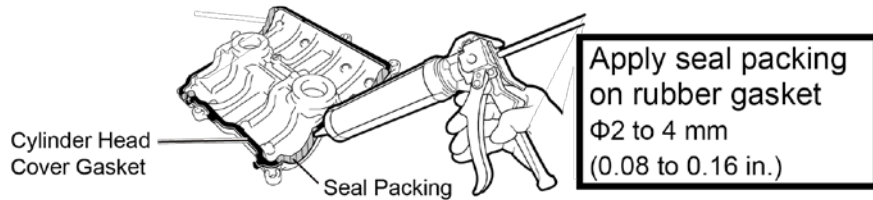

[Locations to Apply Seal Packing]

OK

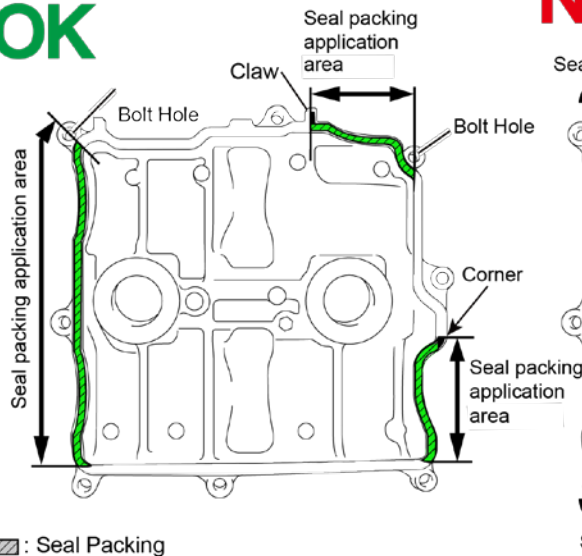

NG **Do not** apply around the whole circumference

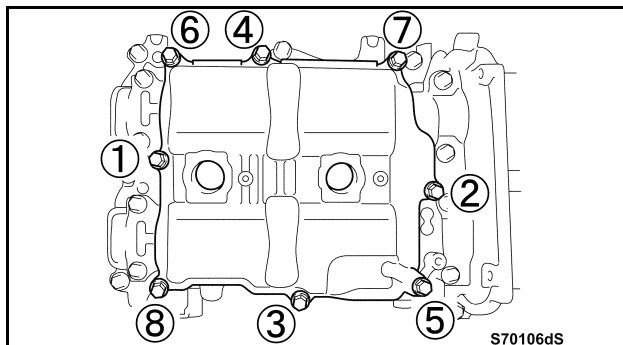
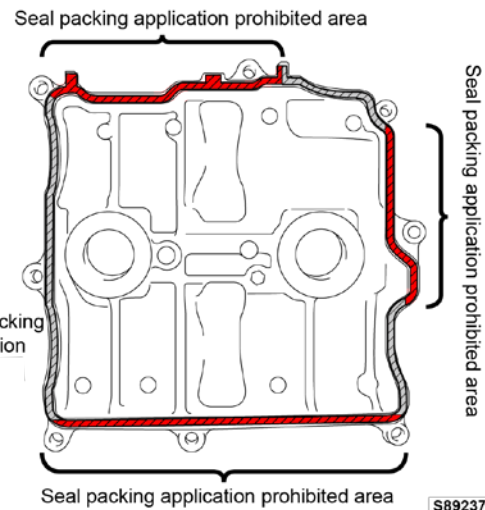

- f) Set the cylinder head cover RH, and uniformly and gradually tighten the 8 bolts in the specified order in several passes, to install it.

Specified torque:

57 in.*lbf (6.4 N*m, 65 kgf*cm)

2. REINSTALL PUMP DRIVE CASE ASSEMBLY

- a) Clean and degrease the contact surfaces between the pump drive case assembly and the engine.

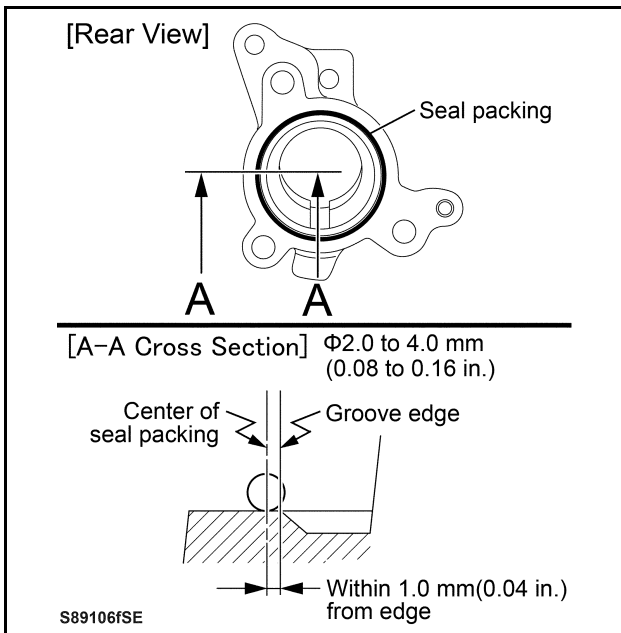

- b) Remove the seal packing, which has got hard, from the tip of the sealer gun.
- c) Apply seal packing to the drive case to the parts specified in the illustration.



Each component must be attached within 5 minutes of seal packing application and all bolts must be tightened to the specified torque within 15 minutes of the application.

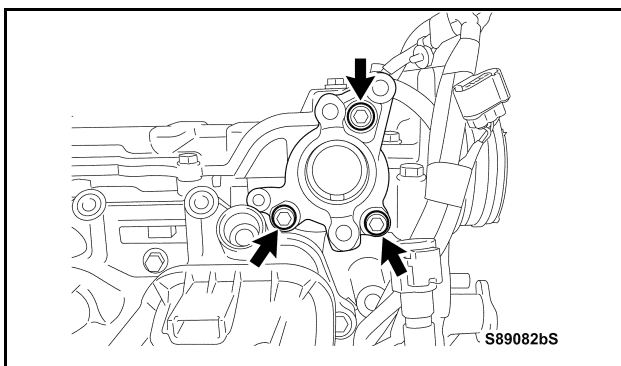

- d) Using a 6 mm (0.24 in.) hexagon socket, reinstall the pump drive case with the 3 bolts.

Specified torque:

14 ft.*lbf (19 N*m 194 kgf*cm)

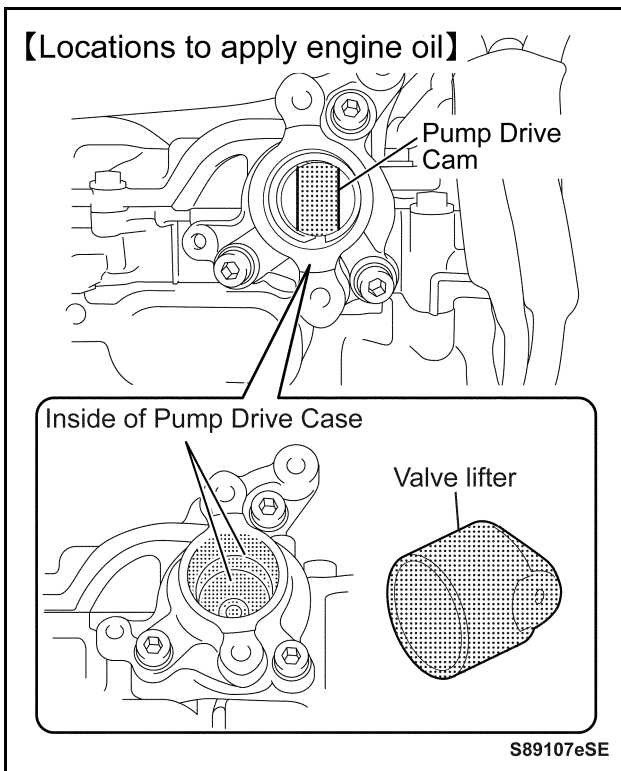

3. REINSTALL VALVE LIFTER (for Fuel Pump)

- a) Rotate the intake camshaft until the flat surfaces of the cam face upward toward the valve lifter attachment hole.

NOTE:

This is to make the pump installation work easier as the camshaft drive surface is not pressed upward by the convex portions of the camshaft.

- b) Apply engine oil to the internal surfaces of fuel pump drive case, the pump drive cam and the entire surfaces of the valve lifter.

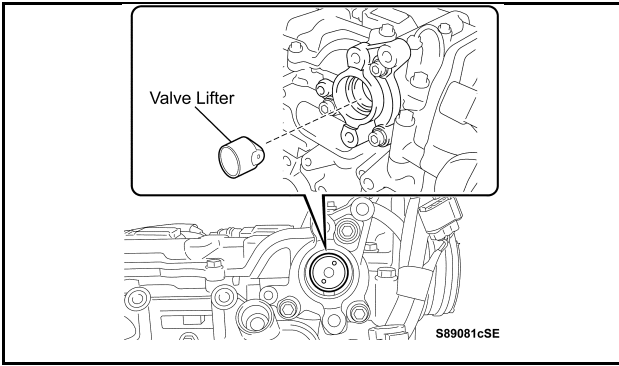

c) Reinstall the valve lifter.

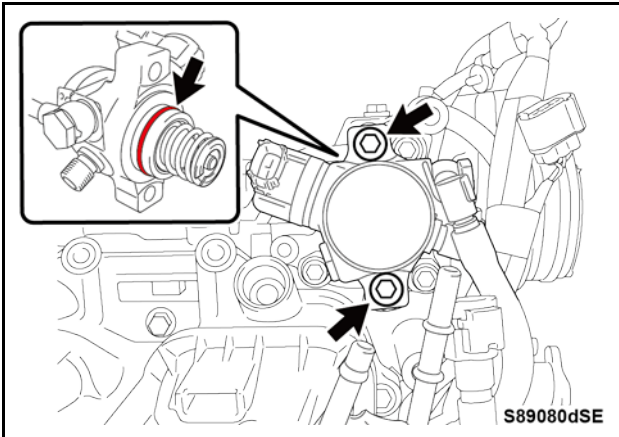

4. REINSTALL FUEL PUMP ASSEMBLY

a) Apply engine oil to a **NEW** O-ring and install it onto the fuel pump assembly.

NOTE:

Part No.: SU003-02187(8069311109R)

φ 31.5 mm (1.24 in.) inner diameter,

φ 35.5 mm (1.4 in.) outer diameter

b) Using “Torx” Plus 40IP socket wrench, reinstall the fuel pump assembly with the 2 bolts.

Specified torque:

15 ft.*lbf (21 N*m, 214 kgf*cm)

5. INSTALL **NEW** NO. 2 FUEL DELIVERY PIPE

a) Route the engine wire as shown and temporarily install a **NEW** No. 2 fuel delivery pipe.

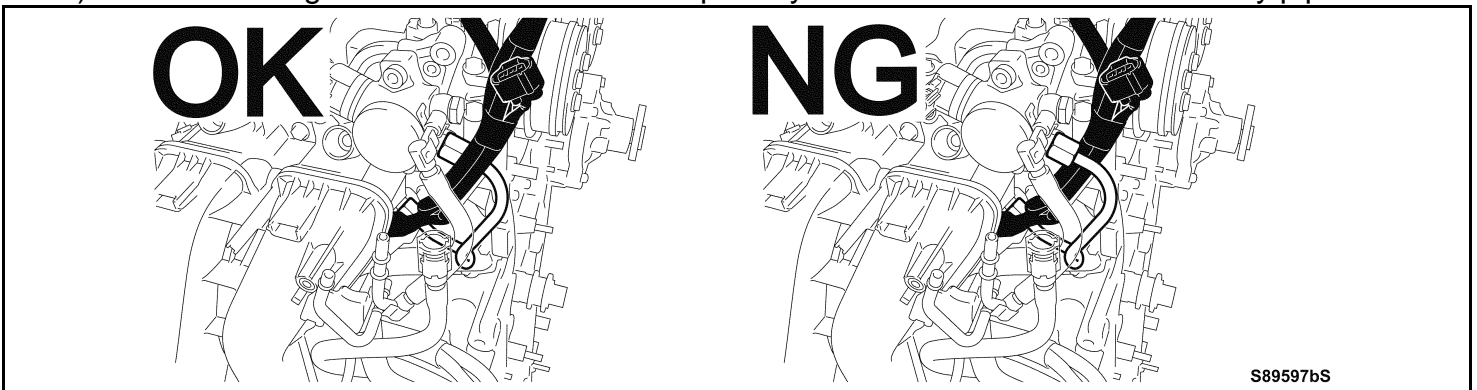

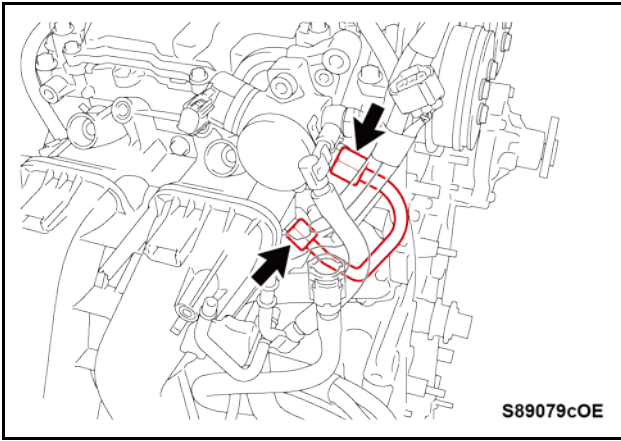

- b) Using a 17 mm (0.37 in.) union nut wrench, uniformly and gradually tighten the delivery pipe in several passes.

Specified torque:

18 ft.*lbf (25 N*m, 255 kgf*cm)



Use the formula below to calculate the torque reading values as the extension tool is used.

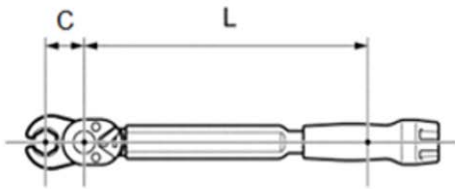

$$\text{Torque Setting (ft.lbs)} = \frac{18 \times L}{C + L}$$

L	Length of torque wrench (in.)
C	Length of crowfoot wrench (in.)

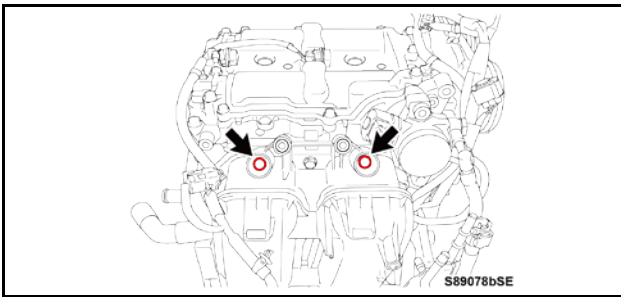

6. INSTALL **NEW** FUEL INJECTOR SEALS

- a) Install 2 **NEW** fuel injector seals (facing either direction).

NOTE:

Part No.: SU003-00324 (16608KA0009R)

ϕ 9.2 mm (0.36 in.) inner diameter,

ϕ 16.0 mm (0.63 in.) outer diameter

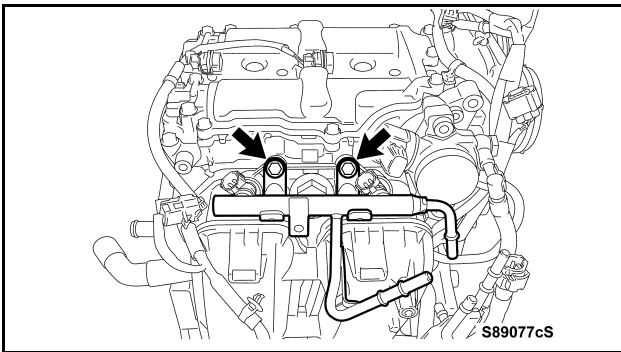

7. REINSTALL FUEL DELIVERY PIPE SUB-ASSEMBLY

- a) Reinstall the fuel delivery pipe sub-assembly together with the delivery pipe.

- b) Reinstall the 2 bolts

Specified torque:

14 ft.*lbf (19 N*m, 194 kgf*cm)

NOTE:

If an injector detaches from the delivery pipe, replace the O-ring and the grommet with **NEW** ones (included in the Valve Spring Kit).

O-ring Part No.:

SU003-00335 (16698AA1109R)

ϕ 7.8 mm (0.31 in.) inner diameter,

ϕ 11.6 mm (0.46 in.) outer diameter

Grommet Part No.:

SU003-00317 (16395AA0209R)

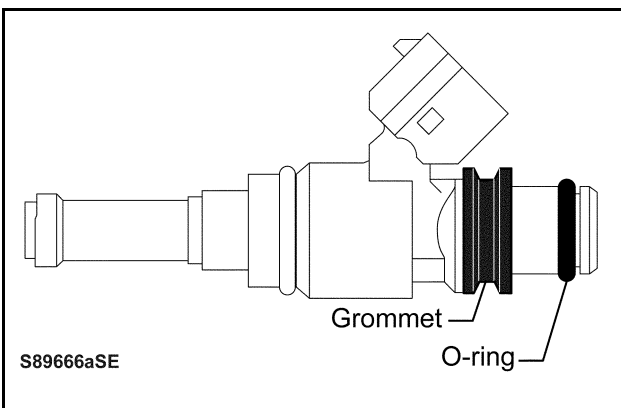

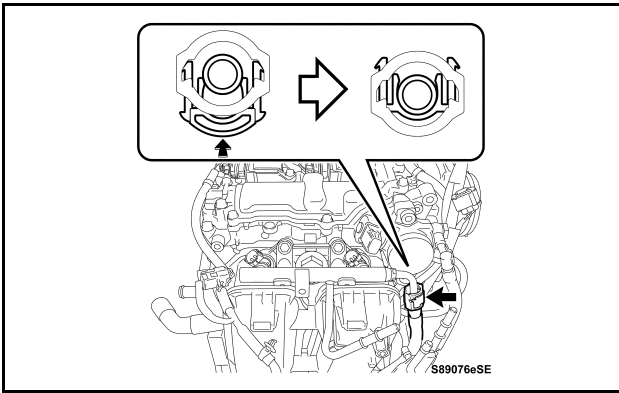

c) Connect the delivery pipe, and securely lock it as shown.

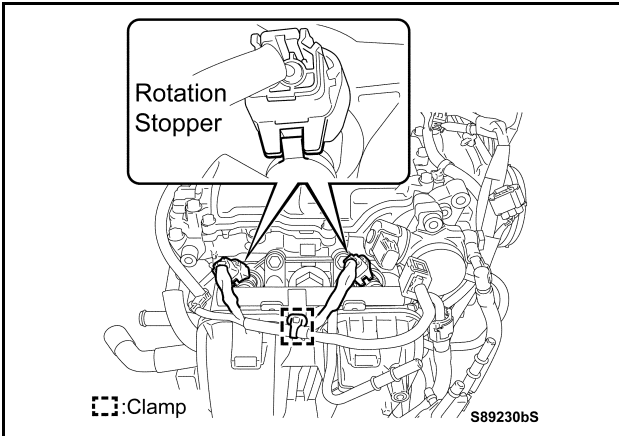

d) Align the concave portion of the rotation stopper with the convex portion, and reconnect the injector connector.

e) Re-engage the clamp.

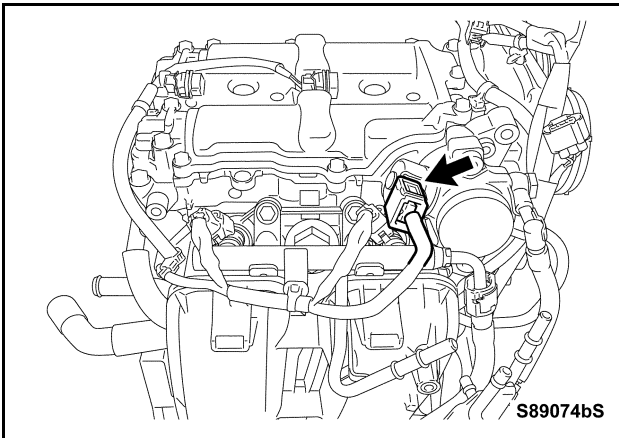

f) Reconnect the connector.

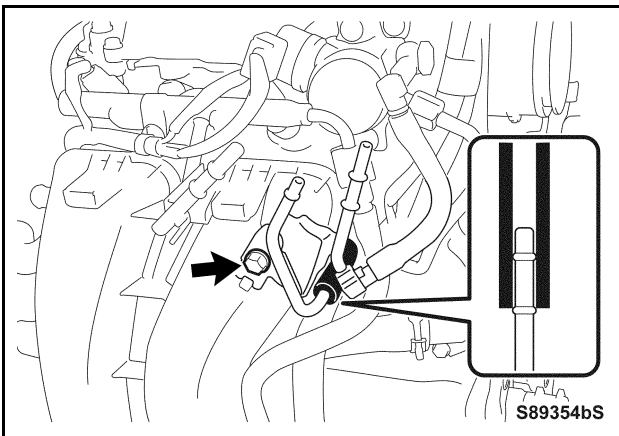

8. REINSTALL FUEL DELIVERY PIPE SUB-ASSEMBLY

a) Insert the tip into the fuel hose until it reaches the position shown in the illustration.

b) Install the fuel delivery pipe sub-assembly with the bolt.

Specified torque:

57 in.*lbf (6.4 N*m, 65 kgf*cm)

XX.REINSTALLATION OF TIMING CHAIN COVER

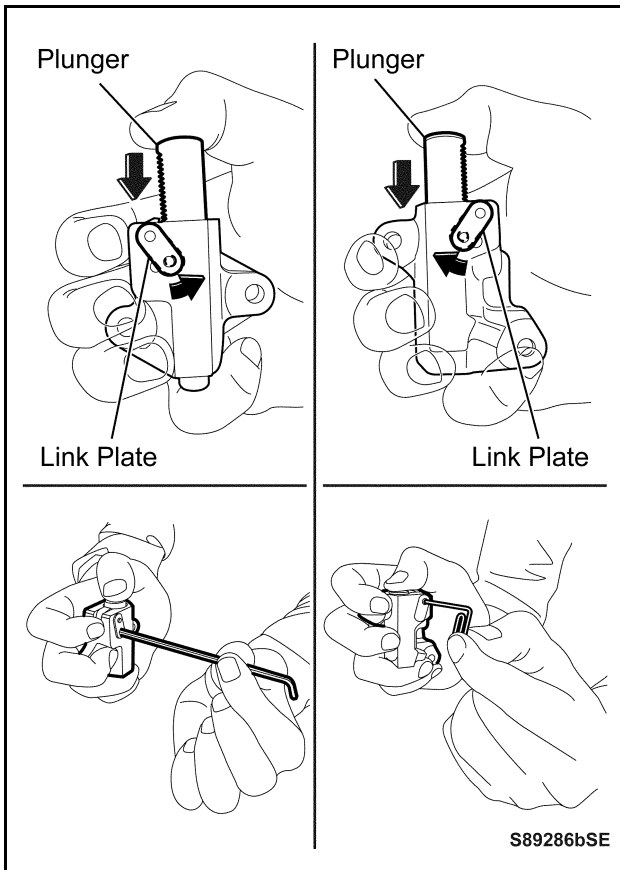

1. PREPARE FOR CHAIN TENSIONERS NO. 1 AND NO. 2 ASSEMBLY INSTALLATIONS

- Move the link plate in the direction of the arrow in the illustration to press in the plunger.
- For the No. 1 chain tensioner assembly: Insert an approximately 2.5 mm (0.1 in.) hexagon wrench into the chain tensioner through the stopper pin hole, and fix the plunger.
- For the No. 2 chain tensioner assembly: Insert a paper clip with a diameter of approximately ϕ 1 mm (0.04 in.) into the chain tensioner through the stopper pin hole, and fix the stopper.

NOTE:

If the holes **DO NOT** align, the teeth inside the tensioner may be misaligned and not properly engaged. In such a case, move the plunger through full stroke several times until the teeth engage properly.

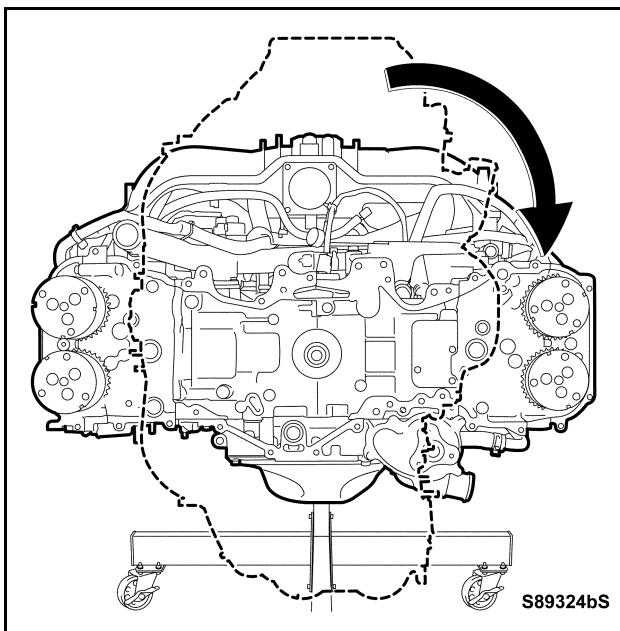

2. CLEAN AND DEGREASE TIMING CHAIN OR BELT COVER INSTALLATION SURFACES AND APPLY SEAL PACKING

- Rotate the engine stand until the intake manifold comes to the top.
- Remove the bolt, the crankshaft pulley and the spacer.

[IMPORTANT] 6 TIPS TO PREVENT WORK ERRORS

- a) Clean and degrease the timing chain or belt cover contact surfaces on the engine main body.
- b) Remove the hardened seal packing from the tip of the sealer gun.
- c) Be sure fill seal packing in the 15 points (gaps between parts) shown in the illustration. If not filled, oil leakage may occur.

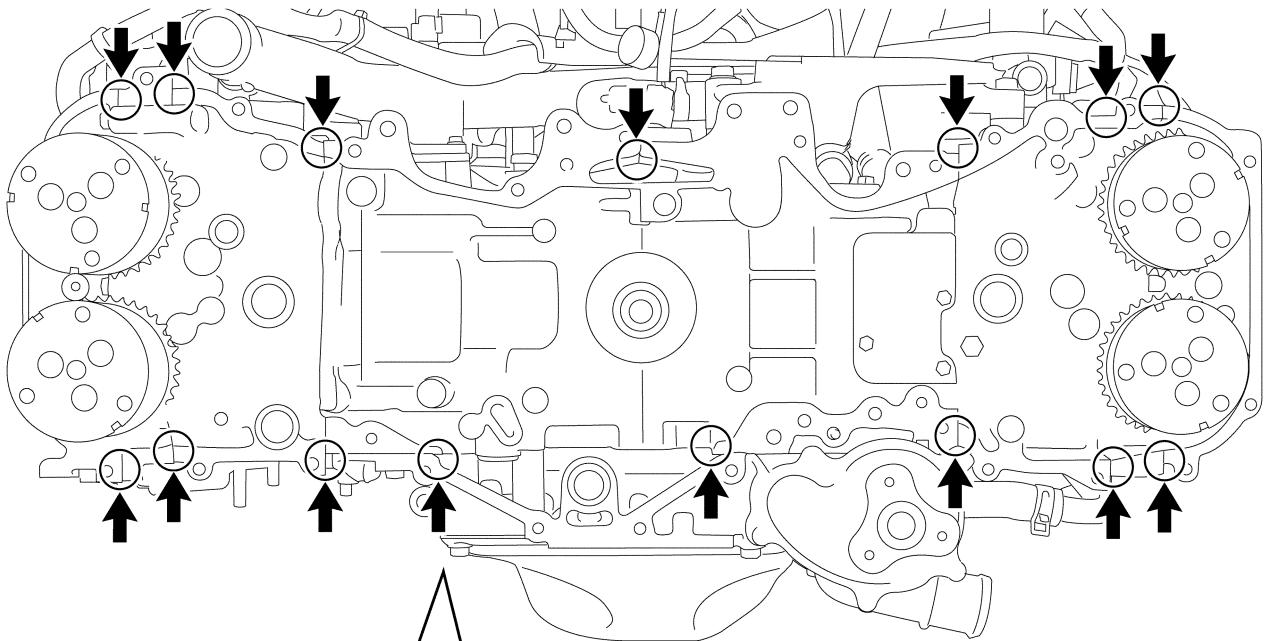

S89353eSE

<Fill seal packing in 15 points (gaps between components)>

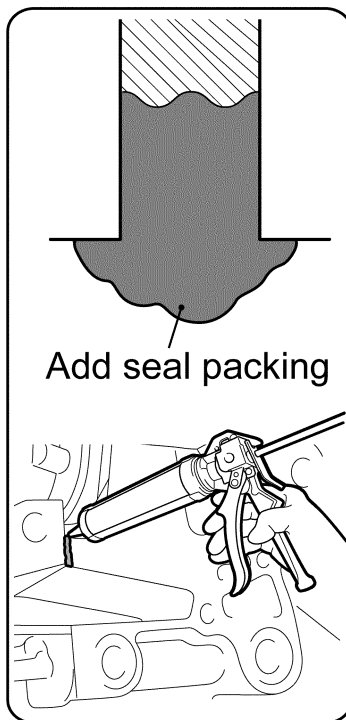
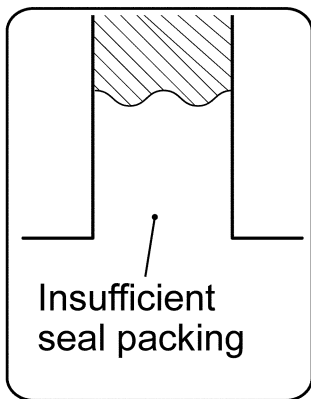

NOTE:
Conceptual cross-sectional image

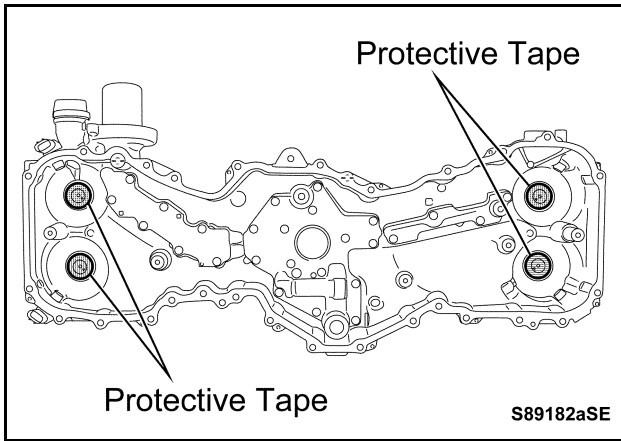

3. CLEAN AND DEGREASE TIMING CHAIN OR BELT COVER SUB-ASSEMBLY

- a) Cover the 4 locations specified in the illustration with protective tape to prevent any debris while cleaning.
- b) Clean and degrease the timing chain or belt cover sub-assembly contact surfaces.
- c) Remove the protective tape.

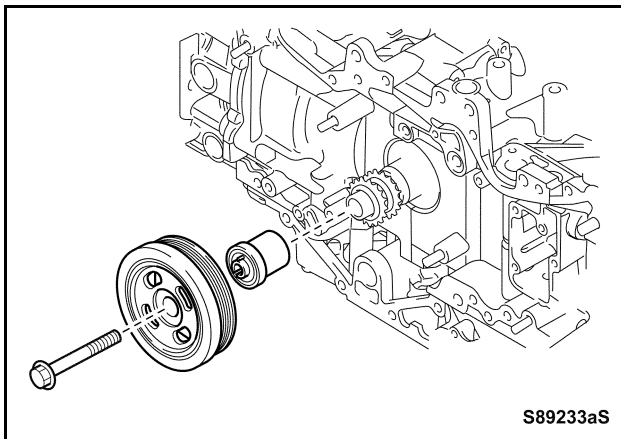

4. REINSTALL CHAIN SUB-ASSEMBLY (for LH Bank)

- a) Temporarily reinstall the spacer, the crankshaft pulley and the bolt.

BE SURE TO WORK AS SPECIFIED IN ORDER

Perform step (b) for the crankshaft, then step (c) for the camshafts.

If step (c) is conducted before step (b), the valve of cylinder No. 3 opens.

Then if step (b) follows step (c), the piston of cylinder No. 3 moves toward the TDC, and this will cause interference between the piston and the valve.

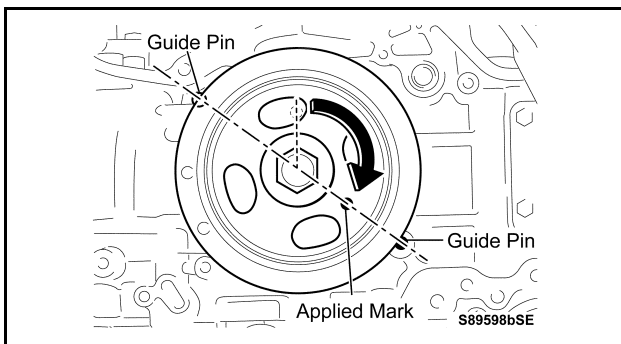
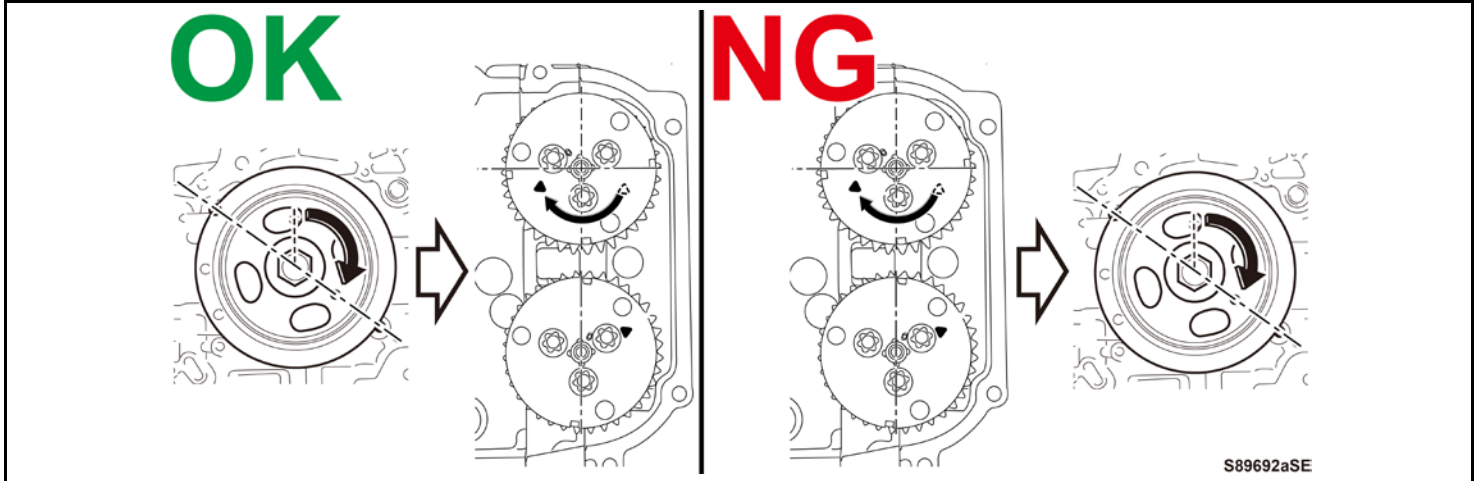

- b) Rotate the crankshaft pulley clockwise until the applied mark on the pulley aligns with the guide pin as shown.
- c) Remove the bolt, the crankshaft pulley and the spacer.

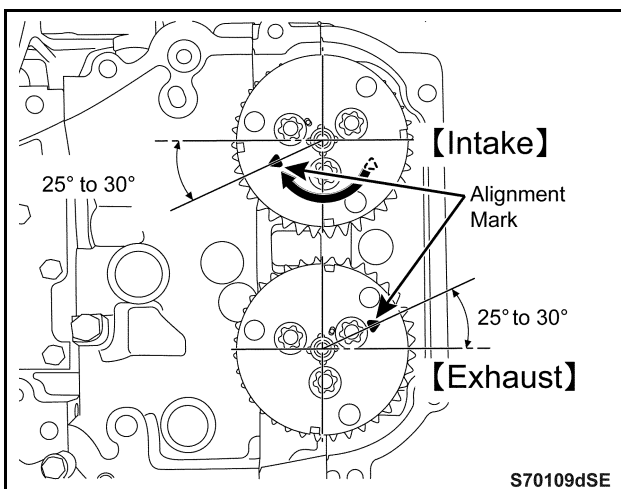

- d) Using SST, rotate the crankshaft and bring the alignment marks on the 2 camshafts on the LH bank to the positions shown in the illustration.

**SST : 09960-10010
(09962-01000, 09963-00700)**

**Intake camshaft: Position where it naturally stops as the cam lift amounts are balanced.
(It is not set to a zero lift position.)**

Exhaust camshaft: Position where all cams are set to zero lift positions.

- e) Remove the bolt, the crankshaft pulley and the spacer.

f) Reinstall the timing chain or belt cover sub-assembly in the following order.



- **DO NOT** allow any foreign matter to enter into or adhere to the components during reinstallation.
- Be sure to reinstall the chain sub-assembly on the bank from which it has been removed from.
- [Click Here to Access the QTG on how to properly time the FA-20 Engine](#)

- 1) Apply engine oil to all component parts of the chain sub-assembly.
- 2) Align the mark plate (blue) on the chain sub-assembly with the alignment mark (oval) on the crankshaft timing gear.
- 3) Align the mark plates (pink) on the chain sub-assembly with the alignment marks (engraved lines) on the 2 camshaft timing gears.

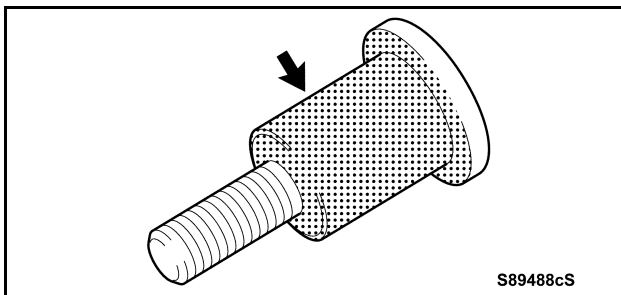
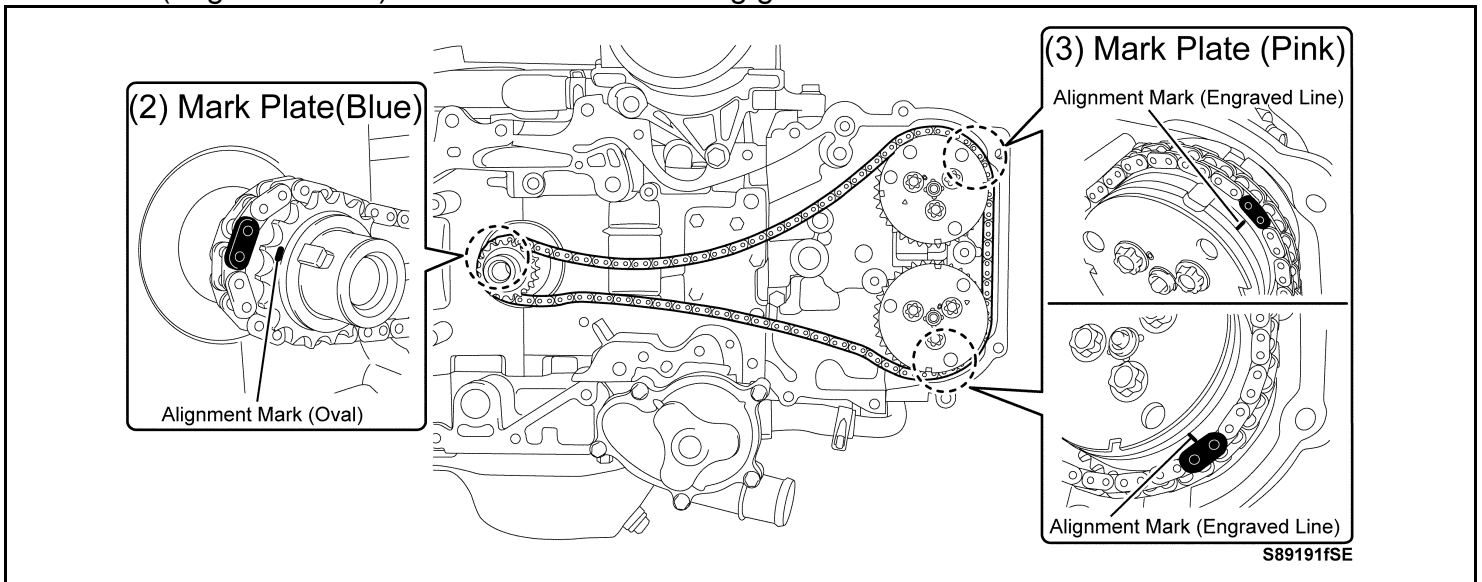

g) Apply engine oil to the sliding portion of the vibration damper bolt.

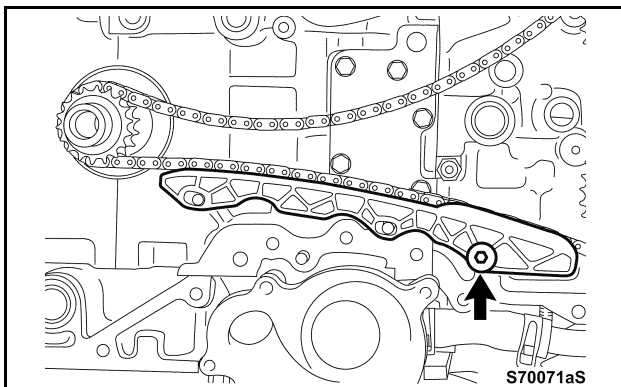

h) Using a 5 mm (0.2 in.) hexagon socket, reinstall the vibration damper with the bolt.

Specified torque:

57 in.*lbf (6.4 N*m 65 kgf*cm)

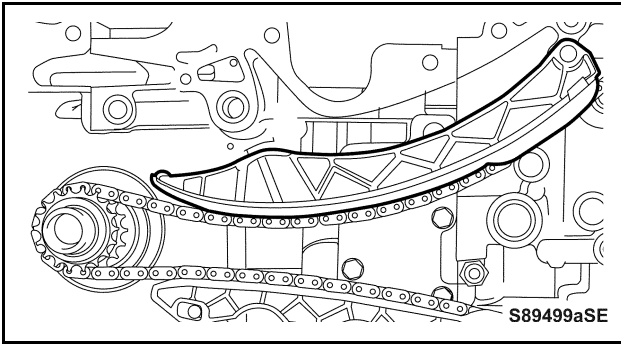

i) Reinstall the tensioner slipper.

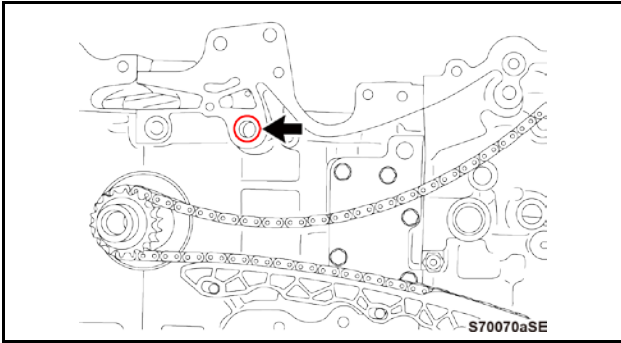

j) Install a **NEW** O-ring for the tensioner.

NOTE:

Part No.: SU003-02185 (8069160809R)

φ 16.1 mm (0.63 in.) inner diameter,

φ 20.7 mm (0.81 in.) outer diameter

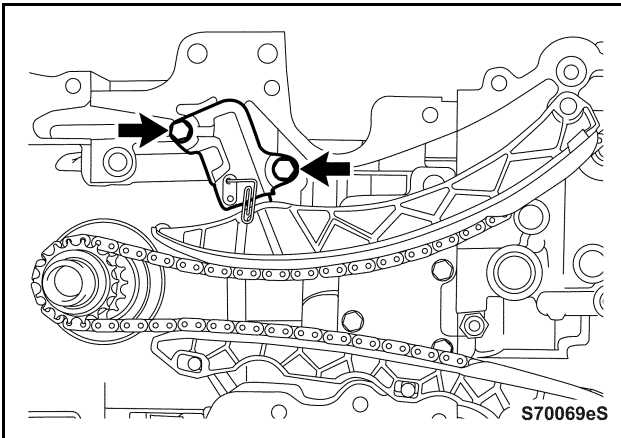

k) Reinstall the tensioner with the 2 bolts.

Specified torque:

57 in.*lbf (6.4 N*m, 65 kgf*cm)

l) Confirm that the 3 marks on the chain sub-assembly are properly aligned.

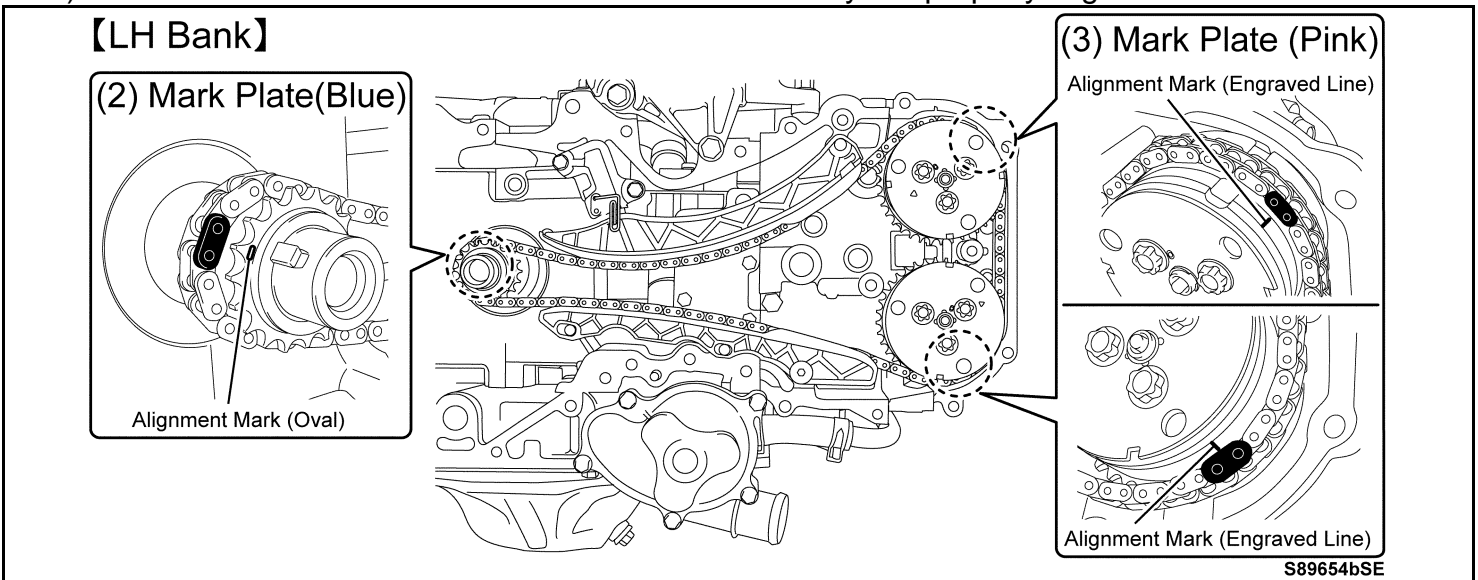

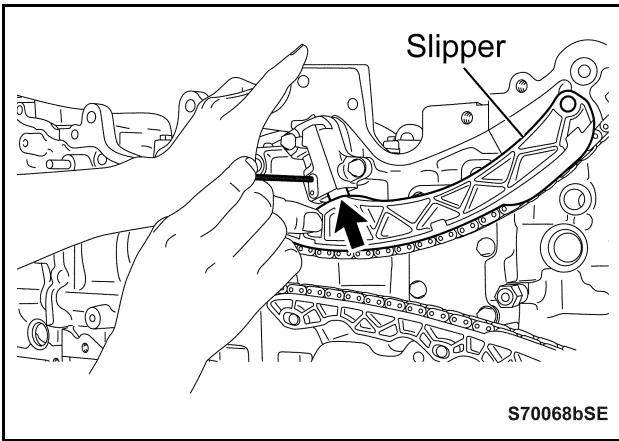

- m) Push the No. 2 tensioner assembly upward by hand, to make it easy to pull out the $\phi 1$ mm (0.04 in.) paper clip.
- n) Pull out the paper clip from the tensioner.

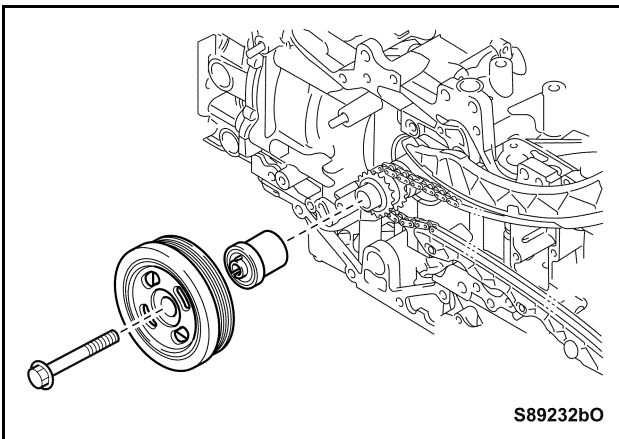

- o) Temporarily install the spacer, the crankshaft pulley and the bolt.

- p) Using SST, turn the crankshaft pulley clockwise to make sure that it rotates smoothly, and turn it until the alignment marks on the intake gear and the exhaust gear and the applied mark on the crankshaft pulley are set in the positions shown in the illustration.
- q) Remove the bolt, the crankshaft pulley and the spacer.

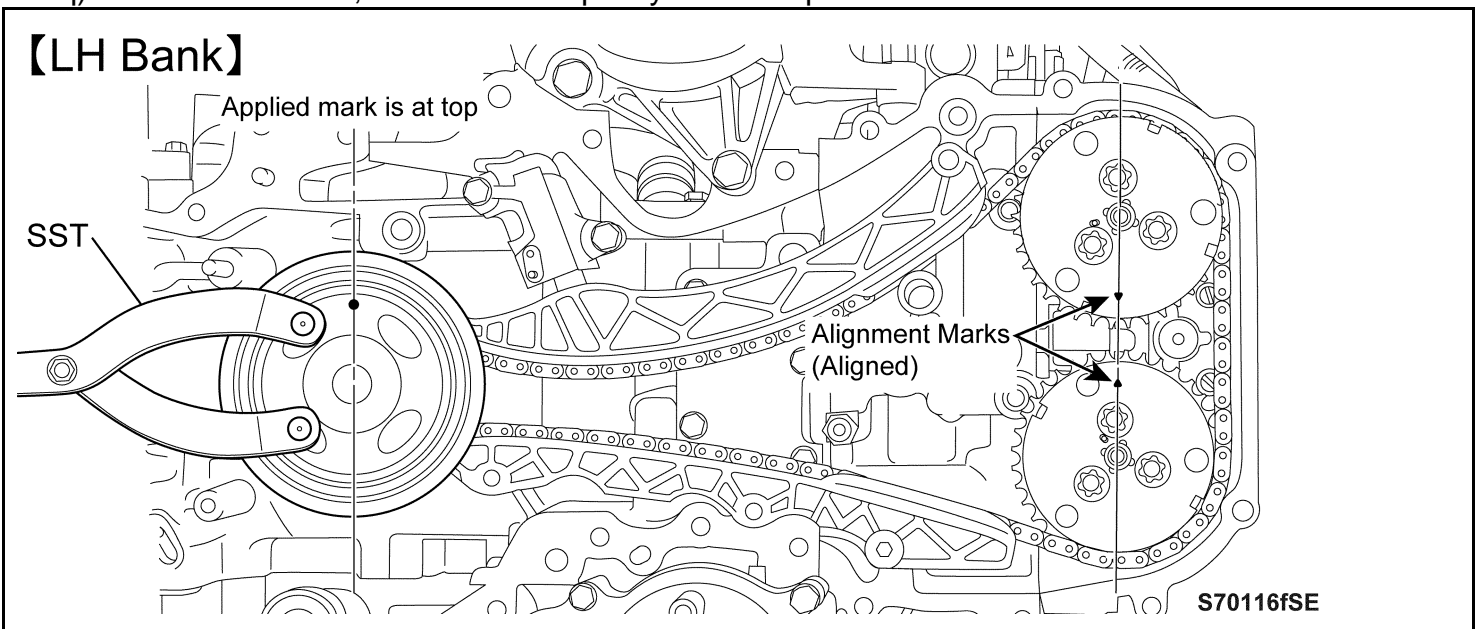

5. REINSATLL CHAIN SUB-ASSEMBLY (for RH Bank)

- a) Reinstall the chain sub-assembly in the following order.



DO NOT allow any foreign material to adhere or enter into the components during reinstallation.

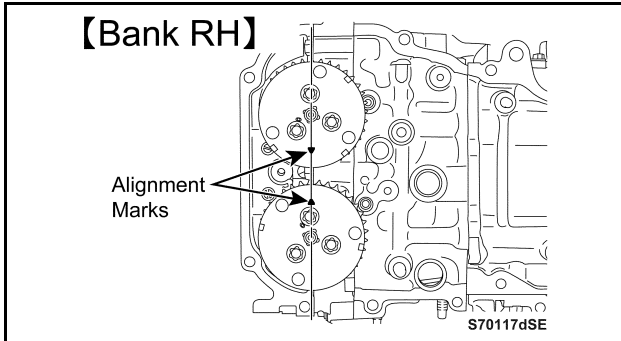

- 1) Align the alignment marks on the 2 camshaft gears as shown in the illustration.

- 2) Apply engine oil to all component parts of the chain sub-assembly.
3) Align the mark plate (blue) on the chain sub-assembly with the alignment mark (oval) on the crankshaft timing gear.
4) Align the mark plates (pink) on the chain sub-assembly with the alignment marks (engraved lines) on the 2 camshaft timing gears.

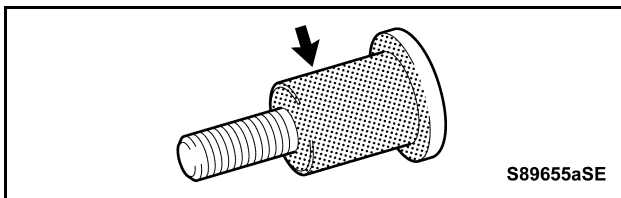
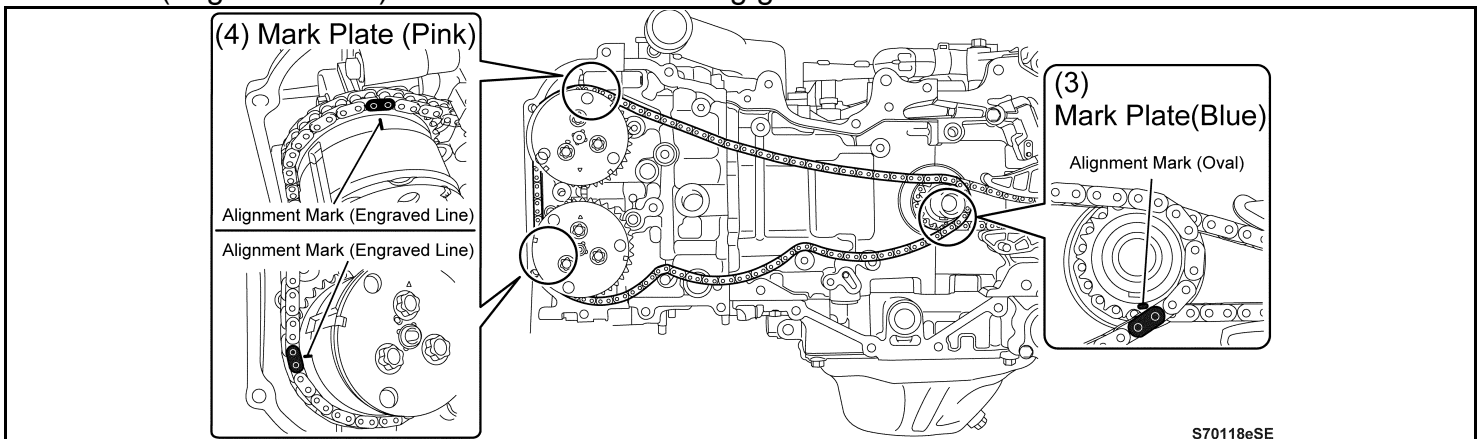

- b) Apply engine oil to the sliding portion of the vibration damper bolt.

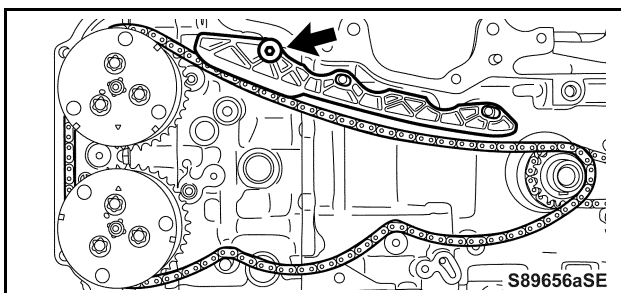

- c) Using a 5 mm (0.2 in.) hexagon socket, reinstall the chain vibration damper with bolt.
- Specified torque:**
57 in.*lbf (6.4 N*m, 65 kgf*cm)

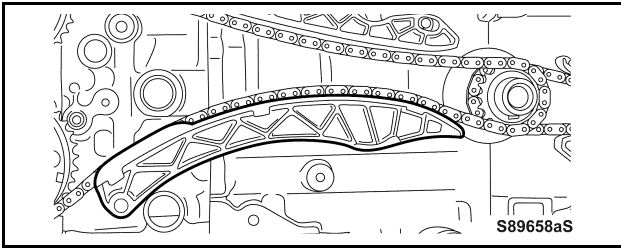

d) Reinstall the chain tensioner slipper.

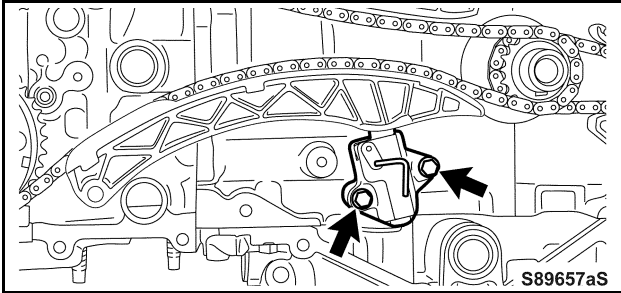

e) Reinstall the No. 1 chain tensioner assembly with the 2 bolts. (w/o O-ring)
Specified torque:
57 in.*lbf (6.4 N*m, 65 kgf*cm)

f) Confirm that the 3 marks on the chain sub-assembly are properly aligned.

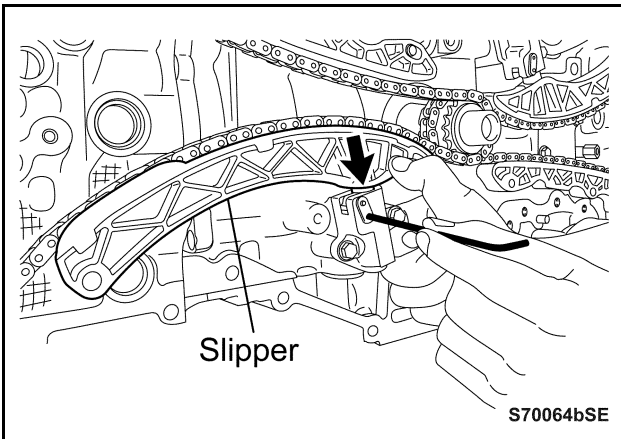
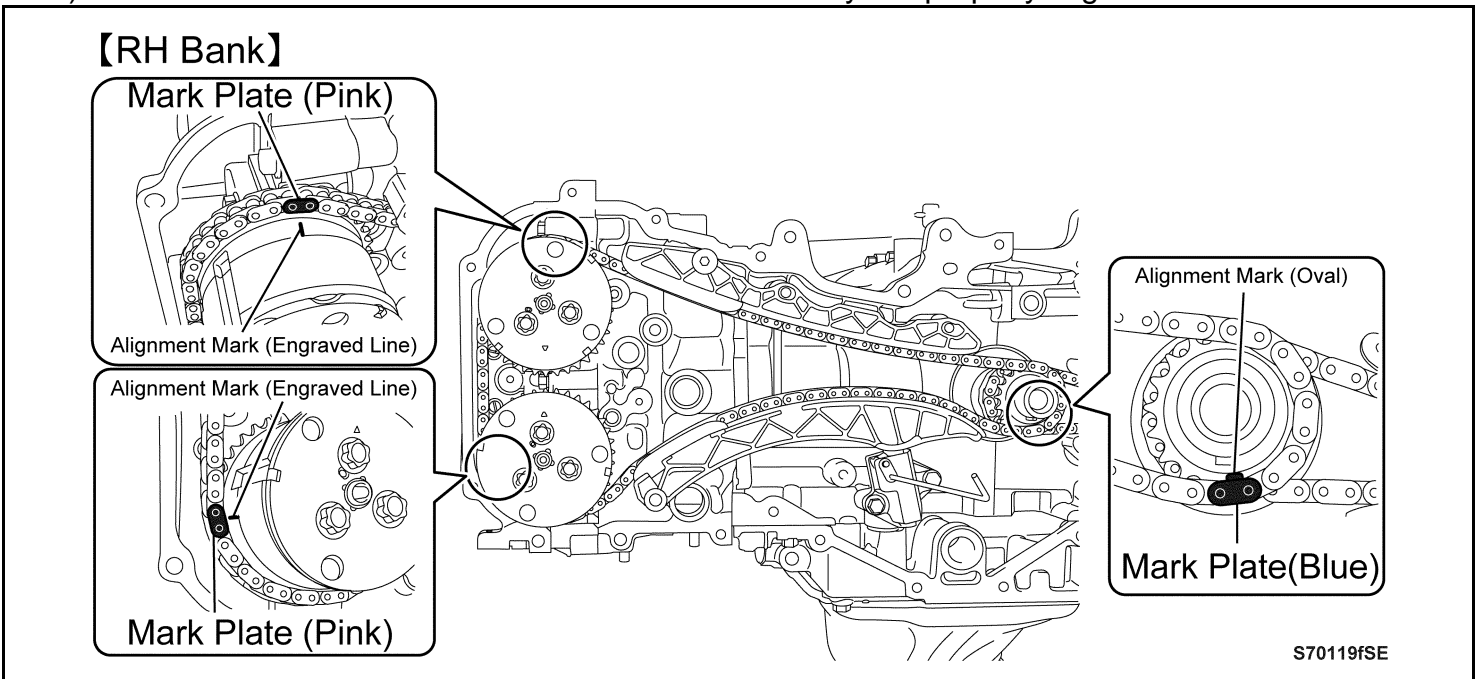

g) Push the No. 1 chain tensioner assembly upward by hand, to make it easier to pull out the hexagon wrench.
h) Pull out the hexagon wrench from the No. 1 chain tensioner assembly.

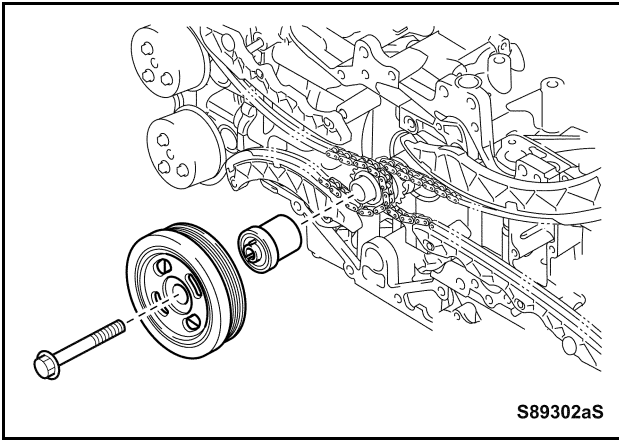

- i) Temporarily install the spacer, the crankshaft pulley and the bolt.

- j) Using SST turn the crankshaft pulley clockwise 2 complete turns to confirm that it rotates smoothly and make sure that the applied mark on the crankshaft and the alignment marks on the RH and LH banks are set in the positions shown in the illustration below.



If the marks *DO NOT* align, remove the chain sub-assembly and start over the reinstallation procedure.

SST : 09960-10010 (09962-01000, 09963-01000)

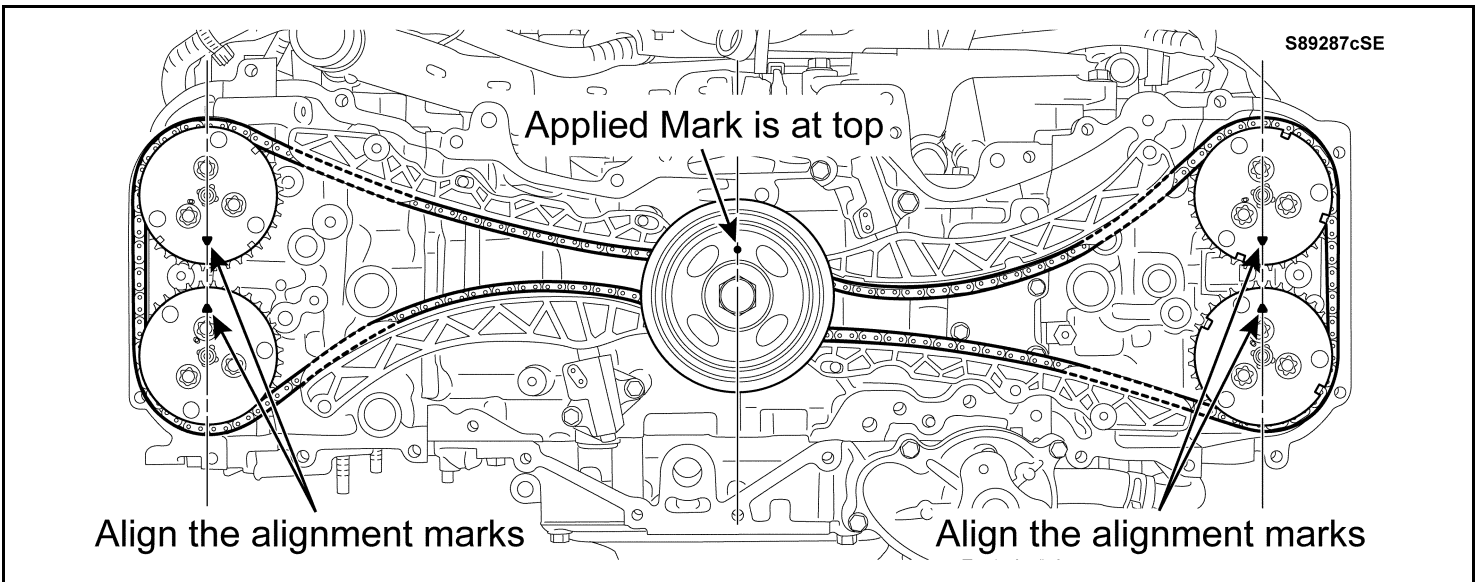

INTERMEDIATE INSPECTION 2

6. CONDUCT INTERMEDIATE INSPECTION 2

- a) Confirm that the chain sub-assembly is properly installed.

Standard: The engine rotates smoothly and each mark is set as shown in the illustration.

(If the alignment marks on the camshafts are not aligned, rotate the crankshaft pulley another full turn.)

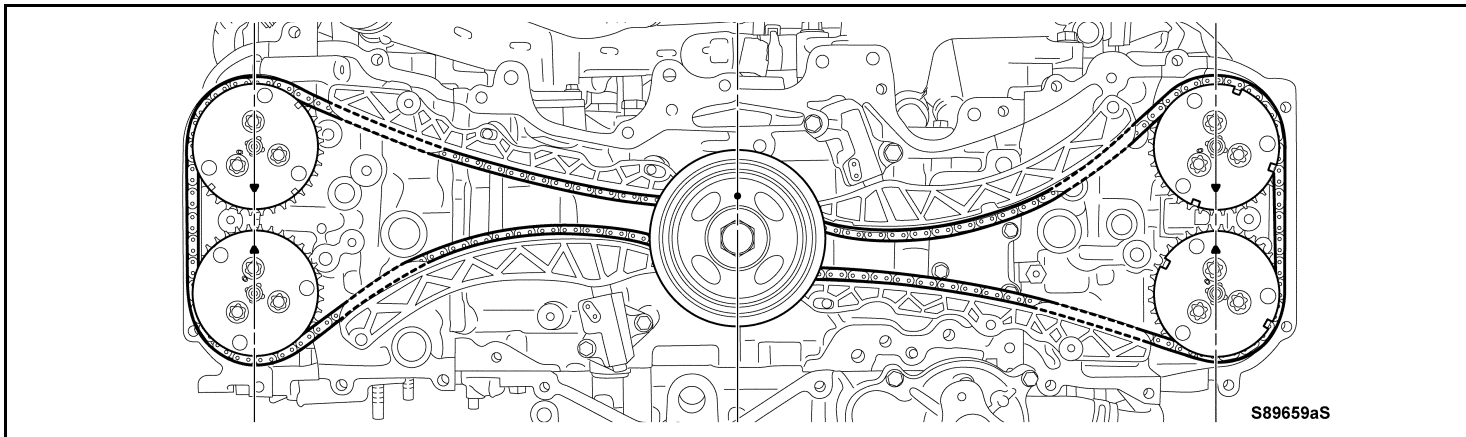

7. TIPS FOR WORKERS REGARDING LATER STEPS

- a) Seal packing must be applied to the timing chain or belt cover assembly as instructed in this manual. Especially, seal packing must be filled into the gaps between the components at the 15 points where the timing chain or cover assembly is to be installed.

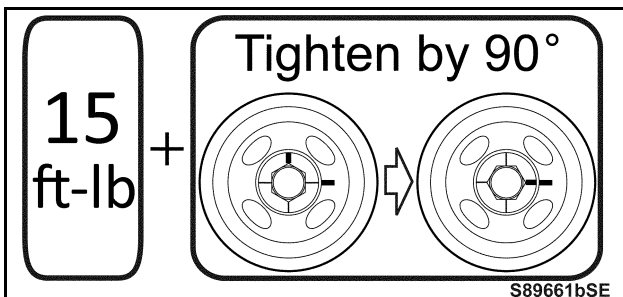
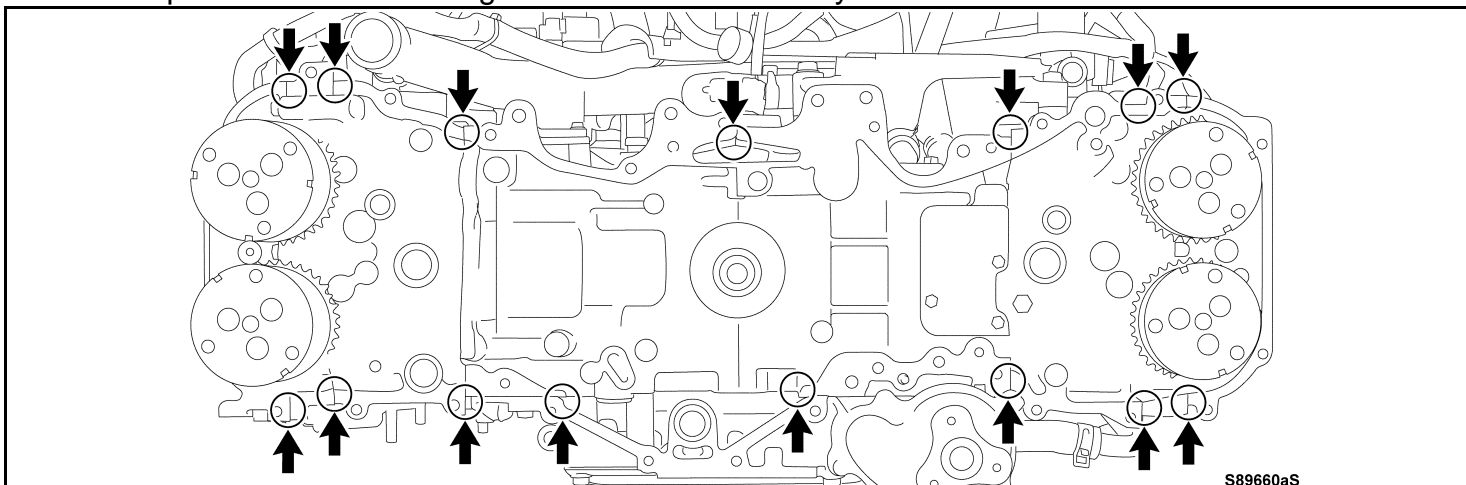

- b) The crankshaft pulley must be tightened properly.
Standard: 20 N*m + 90 degrees (torque and angle controlled tightening)