

**41. SEPARATE FRONT CROSS MEMBER SUB ASSEMBLY FROM ENGINE**

- a) Remove the 2 engine mount nuts from the cross member sub-assembly

**42. REMOVE STARTER ASSEMBLY**

**43. REMOVE FLYWHEEL HOUSING UNDER COVER (for Automatic Transmission)**

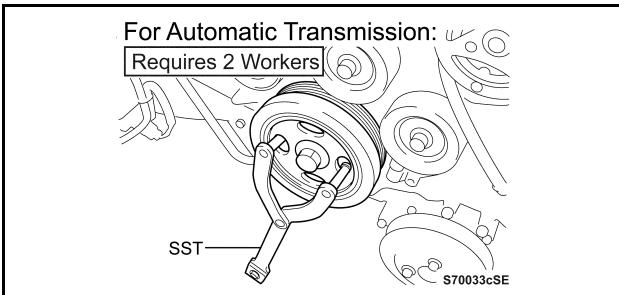

**44. REMOVE DRIVE PLATE AND TORQUE CONVERTER SETTING BOLTS (for Automatic Transmission) (Requires 2 Workers)**

- a) Using SST, hold the crankshaft pulley in place.  
**SST : 09960-10010**  
**(09962-01000, 09963-01000)**
- b) Set a piece of cloth on the service hole to prevent the bolts from falling in.
- c) Remove the 6 bolts through the service hole, while another worker holds the crankshaft pulley.

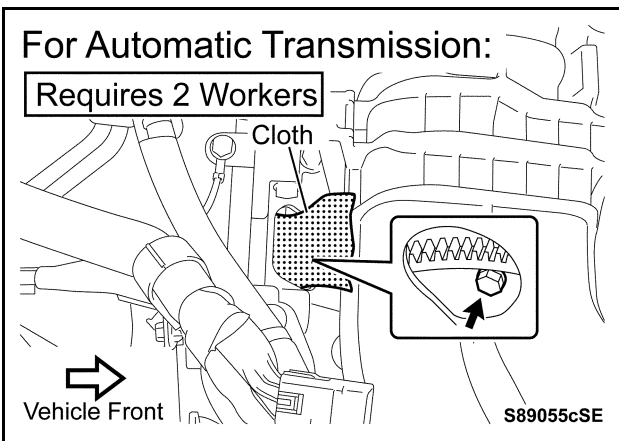

- d) Remove the cloth.

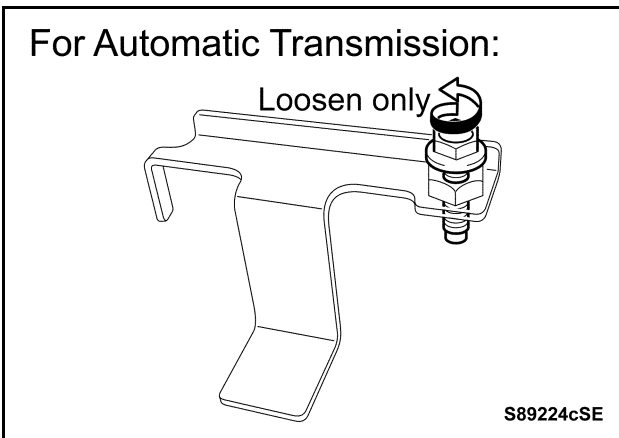

**45. ATTACH TORQUE CONVERTER STOPPER (for Automatic Transmission)**

**NOTE:**

The torque converter stopper is a tool for prevention of fluid leakage if the torque converter detaches together with the engine when the engine block is separated from the transmission assembly.

- a) Loosen (**DO NOT** remove) the bolt for the tool.

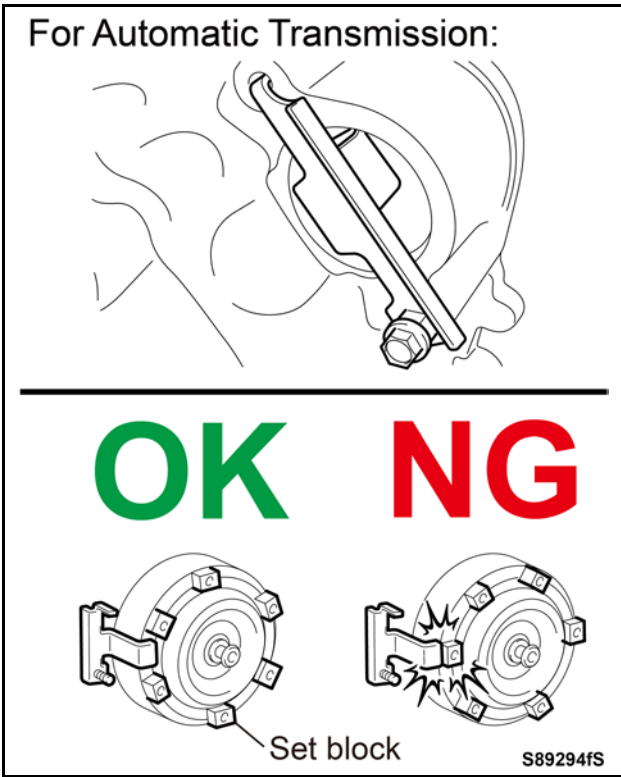

- b) Attach the torque converter stopper to the starter installation hole.
- c) Turn the torque converter by hand and change the set block position if the torque converter stopper cannot be installed due to interference with the set block.
- d) Tighten the bolt to prevent the torque converter stopper from falling.

**NOTE:**

Even after the bolt is tightened, a rattle will remain in the stopper. However, due to the protrusion of the bolt tip, the stopper will be prevented from falling.

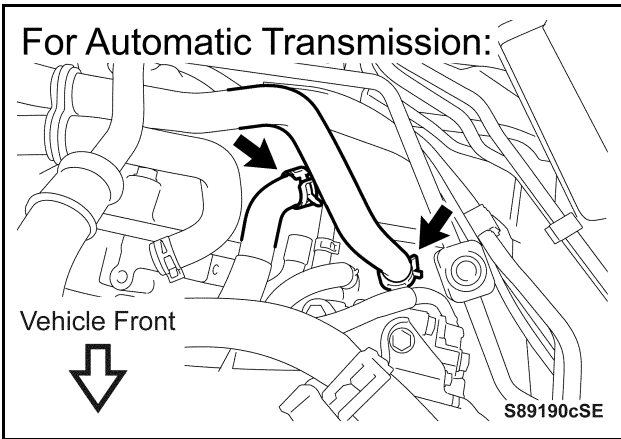

**46. DISCONNECT TRANSMISSION OIL COOLER HOSE NO. 3 AND HEATER WATER HOSE OUTLET B (for Automatic Transmission)**

- a) Disconnect the 2 hoses shown in the illustration.
- b) Plug the disconnected ends with hose plugs or cover them with plastic bags to prevent coolant from flowing out.

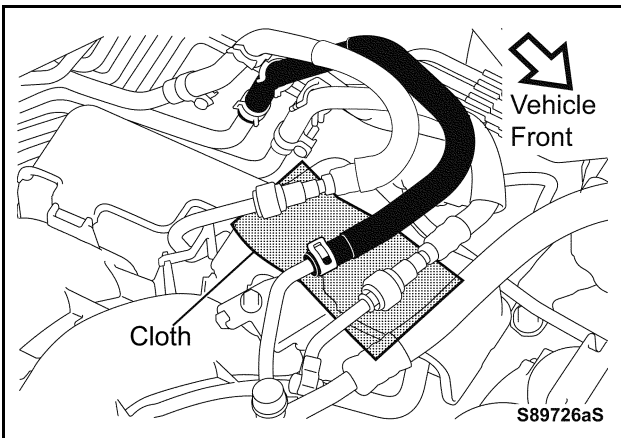

**47. DISCONNECT FUEL HOSE NO.2**



**Fuel hose No. 2: Hose in the middle  
The hose and the clamp will be reused.**

- a) Lay out cloths for the disconnected hoses as fuel will trickle out.

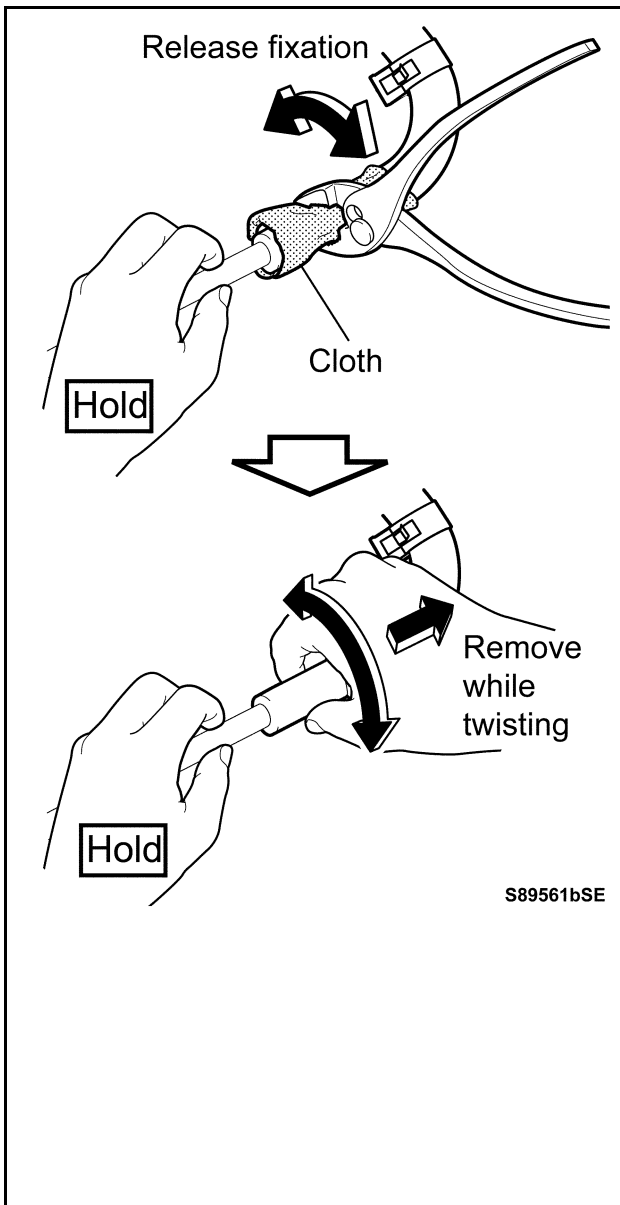

- b) Be sure to observe the following instructions and disconnect the fuel hose No. 2 without damaging or applying excessive force on it, as the hose fittings are hard.
- 1) Move the clamp.
  - 2) Wrap cloth around the hose for a thick cushion.
  - 3) Grip the hose wrapped in cloth with pliers after setting the pliers to the wide opening.
  - 4) While firmly holding the pipe in one hand, operate the pliers with the other hand and twist the hose in a circular direction to break the adhesion.



**DO NOT grip too strongly with the pliers. The hose may be deformed by the pipe being removed.**

- 5) While firmly holding the pipe in one hand and twisting the hose in a circular direction with the other hand, slowly pull out the hose, taking time.



**Be careful not to hit your hand when pulling out the hose from the pipe.**

- c) Protect the disconnected ends of the hose and the pipe with plastic bags etc., to prevent contaminants, damage, and fuel leakage.

#### 48. DISCONNECT FUEL HOSE NO.1 AND FUEL HOSE NO.3

## VIII. REMOVAL OF ENGINE ASSEMBLY

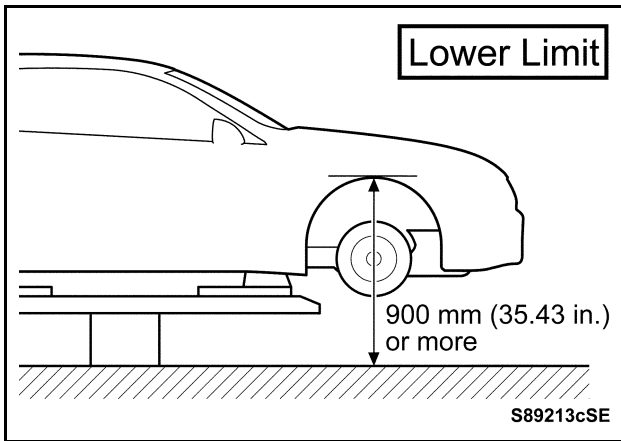

### 1. ADJUST VEHICLE LIFT UP HEIGHT



The height of the lift cannot be changed after separating the engine from the transmission.

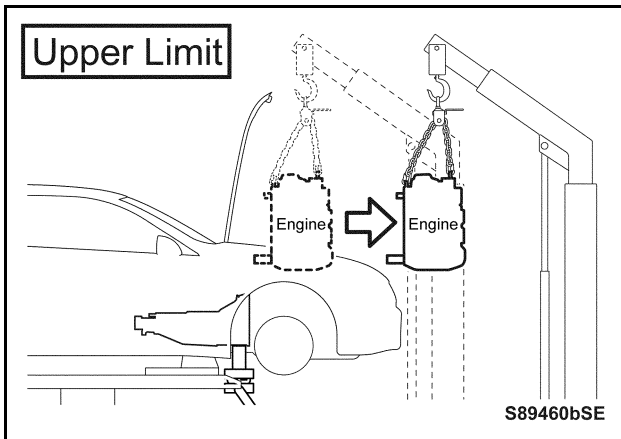

- Lower limit: The dimension shown in the illustration must be 900 mm (35.43 in.) or more.
- [For reference: Work that will be done under the vehicle]
  - Setting of the transmission support attachment on a garage jack to support the transmission.
  - Setting of the exhaust manifold to head gaskets between the exhaust manifold and engine upon engine reinstallation.
- Upper limit: Height where the engine is able to be loaded and unloaded using the specified engine sling device.

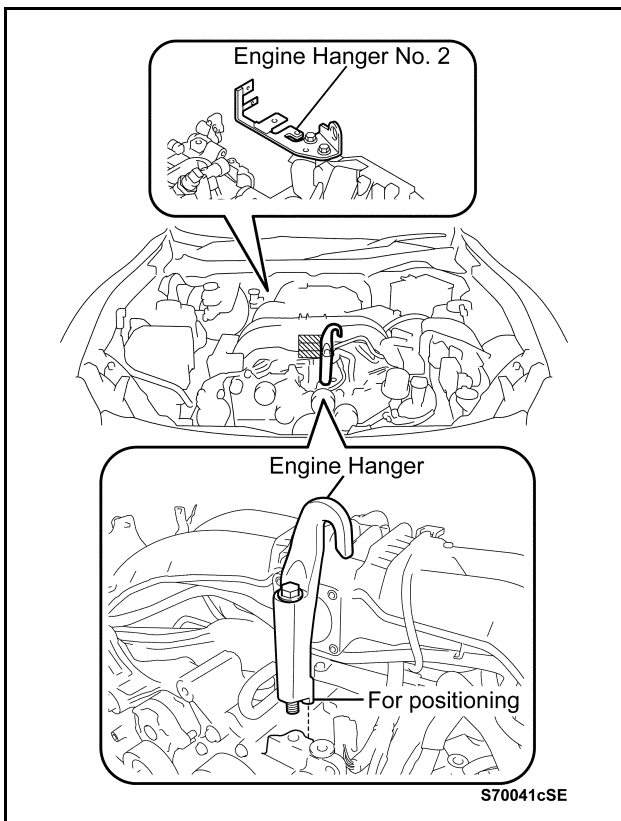

### 2. ATTACH ENGINE HANGER

- Attach the engine hanger with the bolt.  
**Specified torque:**  
**32 ft.\*lbf (43 N\*m, 438 kgf\*cm)**

#### NOTE:

Engine hanger No. 2 is installed to the engine.

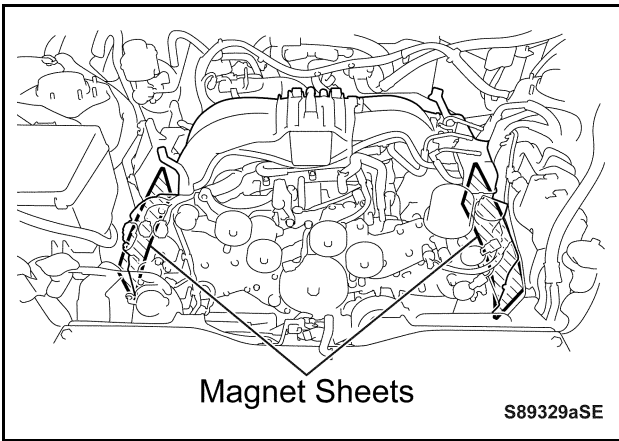

### 3. ATTACH MAGNET SHEET

- a) Attach the magnet sheets to the positions shown in the illustration to prevent damage to the painted surfaces inside the engine compartment due to the engine swinging left and right during its removal and reinstallation.

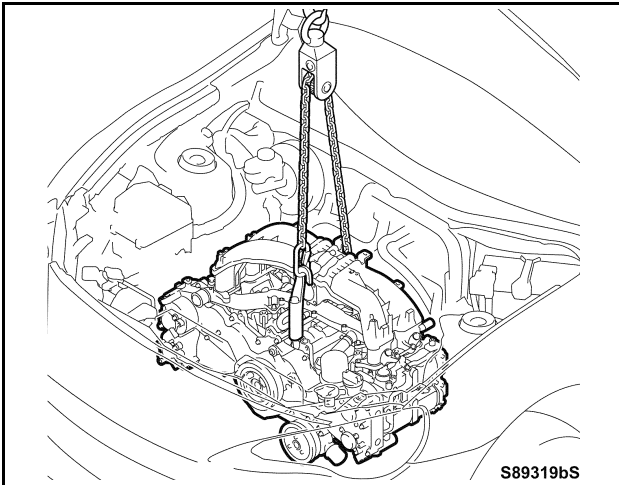

### 4. REMOVE EXHAUST MANIFOLD TO HEAD GASKETS

- a) Attach a chain block to the engine hangers as shown.

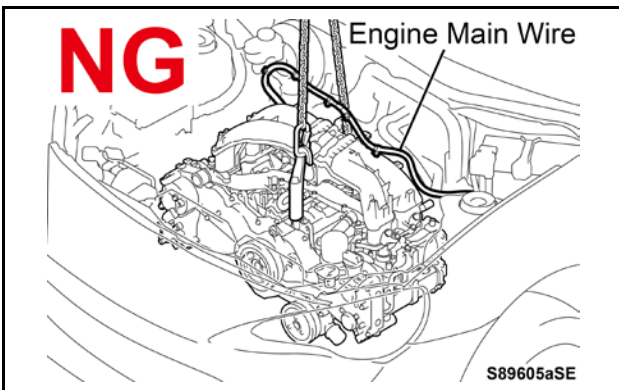

**DO NOT** attach the chain block as shown, as the engine would become unable to be removed due to interference with the engine main wire.

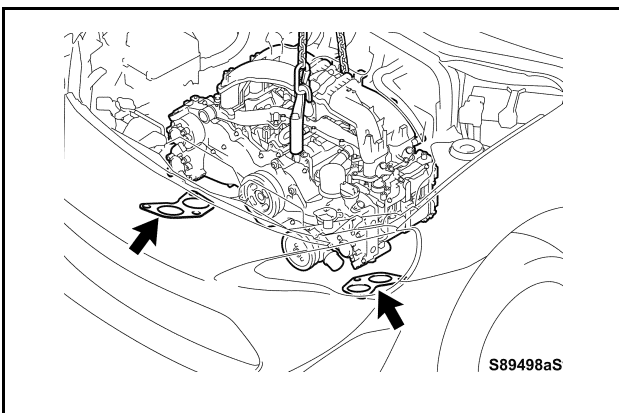

- b) Hoist the engine (approximately 35 mm (13.8 in.)) until the exhaust manifold to header gaskets are able to be removed with the chain block and a mini crane, etc.
- c) Remove the 2 exhaust manifold to header gaskets.
- d) Mark and store the removed gaskets in a separate container so as not to reinstall them in error.

## 5. SUPPORT TRANSMISSION

- a) Set the transmission support attachment on top of a garage jack and place it under the clutch housing area, in the location specified in the illustrations, to support the transmission assembly.

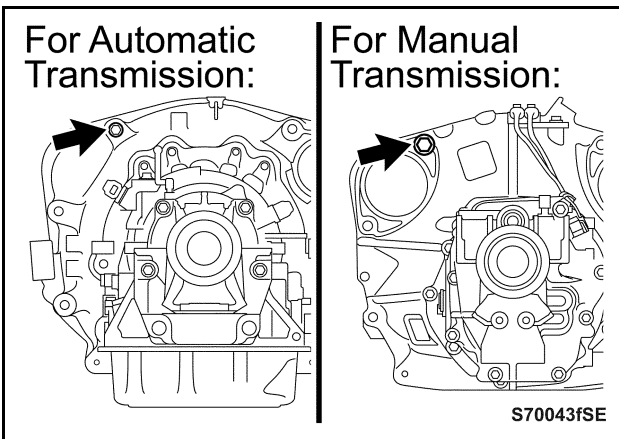
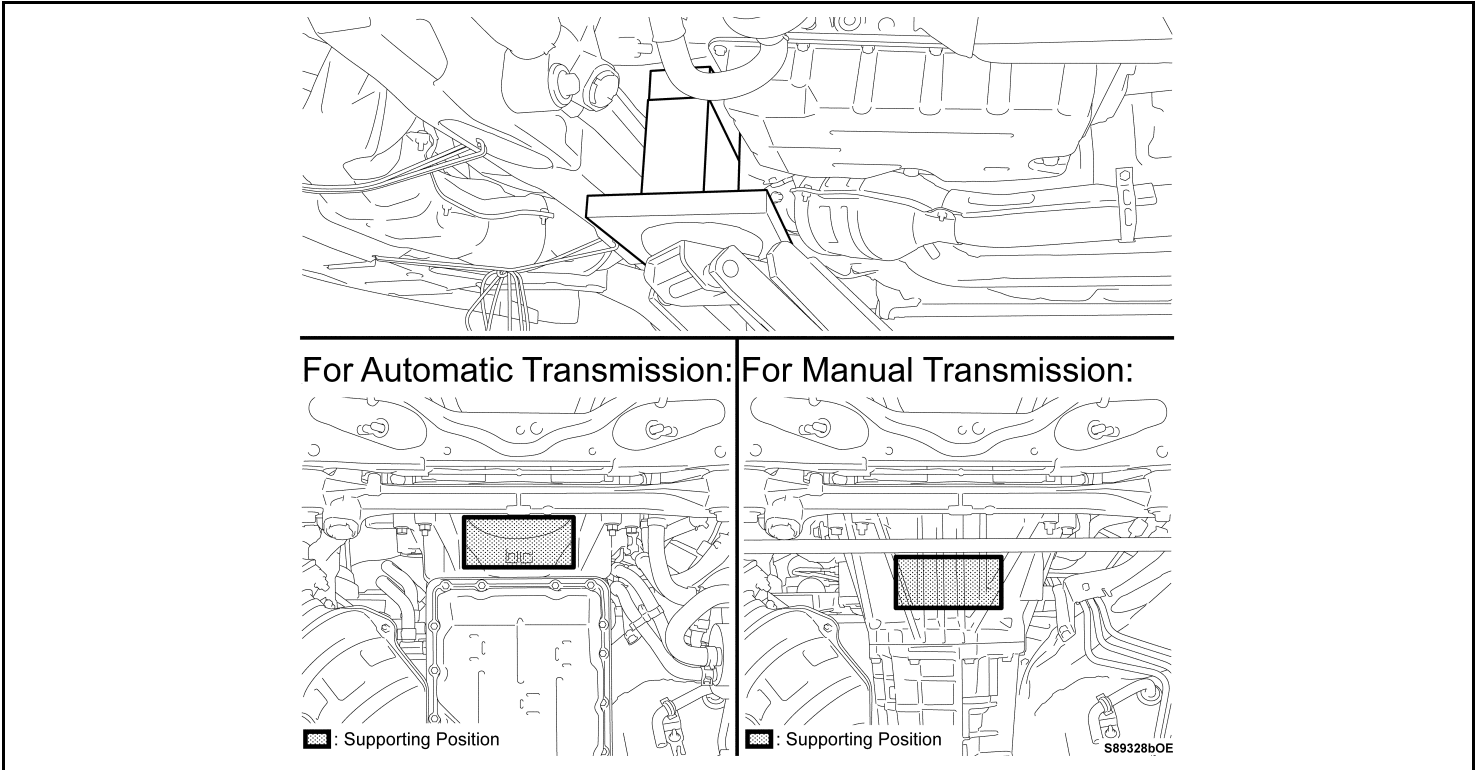

## 6. REMOVE ENGINE ASSEMBLY (Requires 2 Workers)

- a) Remove the final transmission and engine coupling bolt.
- b) Pull the engine forward until the engine is disconnected from the transmission.



**DO NOT pull the engine with excessive force, or it may hit and damage the surrounding components.**

- c) Lift the engine until it reaches the height where it can be pulled forward.



**DO NOT pull and damage any wire harnesses, air conditioning pipes, fuel hoses, etc.**

- d) Pull the engine forward to remove it from the vehicle.

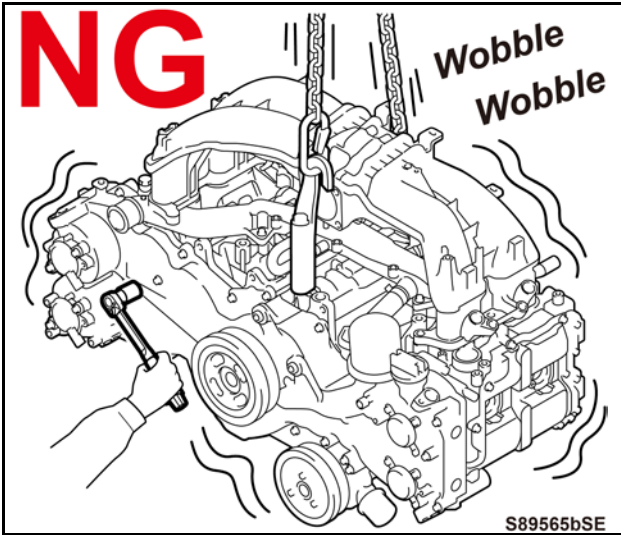

**7. ATTACH ENGINE TO STAND**



**DO NOT** perform any work on the engine while it is suspended, as is dangerous to do so.

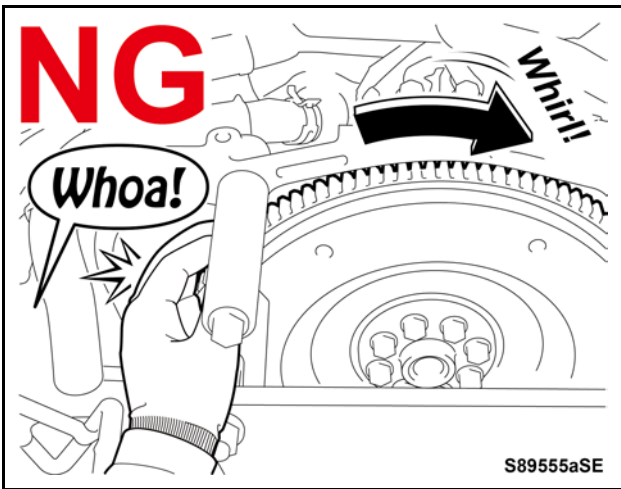

**DO NOT** place hands on the engine stand arm or the rear end of the engine while another worker rotates the engine crankshaft. Fingers or hands may get caught in the ring gear.

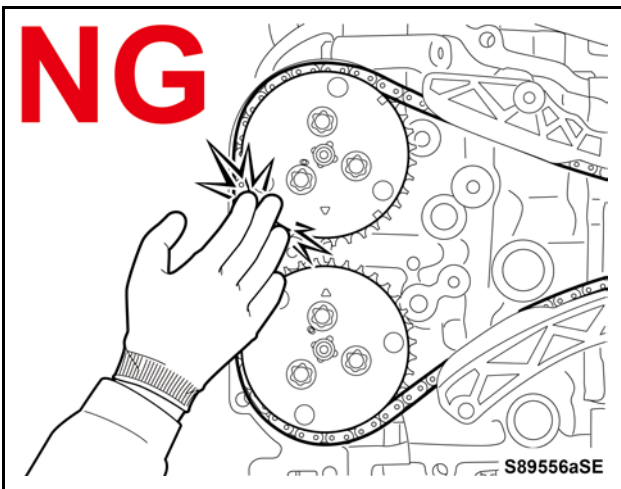

Take care not to get hands or tools get caught when rotating the crankshaft, as the valve system gears, chains, and shafts move.

- a) Using the 4 bolt holes shown in the illustration, set the engine on an engine the stand with the 4 fixing bolts.



**If bolt holes other than the ones instructed are used, there may be a burden on other parts and cause an oil leakage problem.**

**Specified torque:**

**Engine and engine stand bolts: 37 ft.\*lbf (50 N\*m, 510 kgf\*cm)**

**Stand arm bolt and nuts: 59 ft.\*lbf (80 N\*m, 816 kgf\*cm)**

**HINT:**

- Length of bolt A under head:  $a + 32 \text{ mm}$  (1.26 in.)
- Length of bolt B under head:  $a + 36 \text{ mm}$  (1.42 in.)

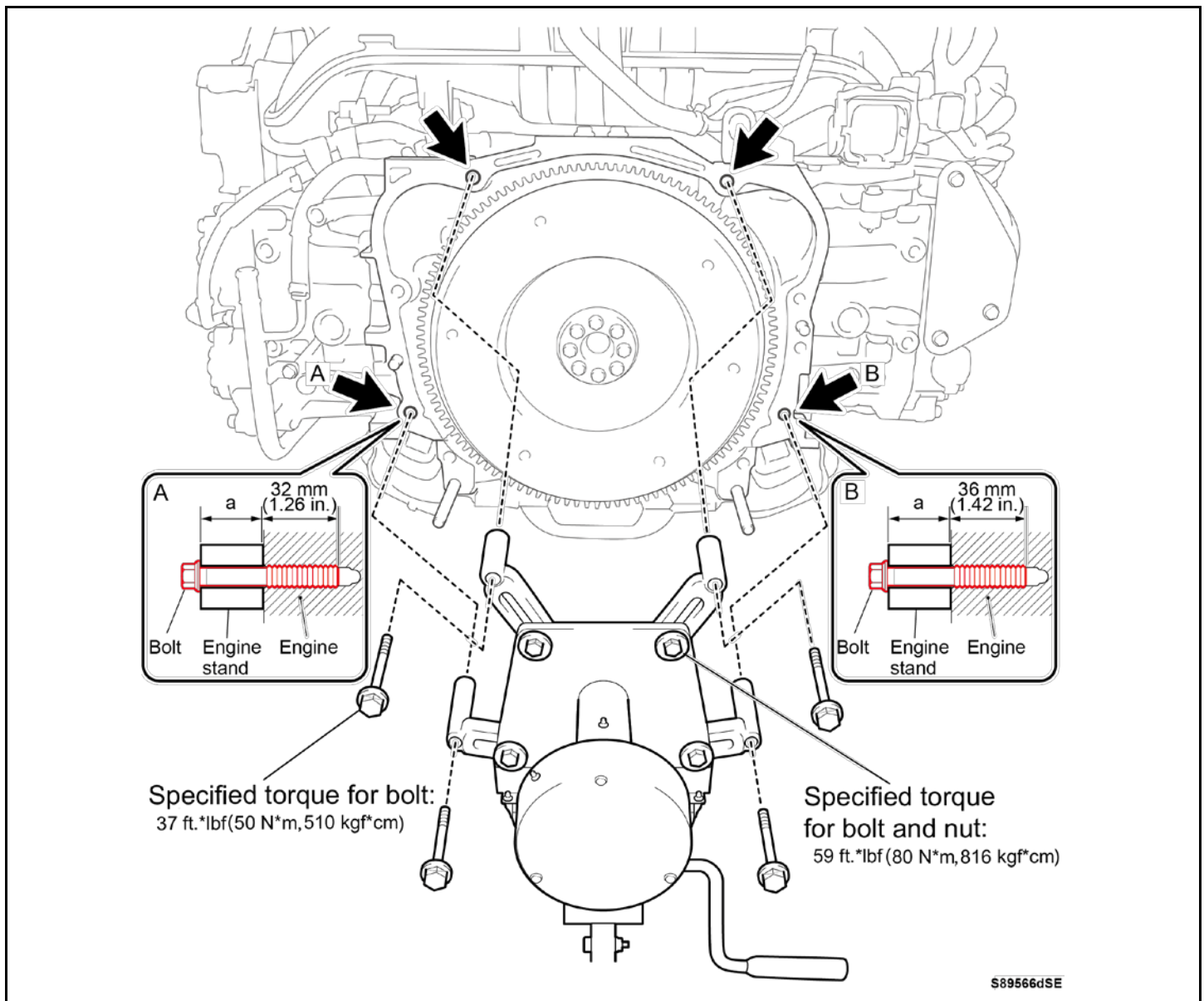



## IX. REMOVAL OF TIMING CHAIN

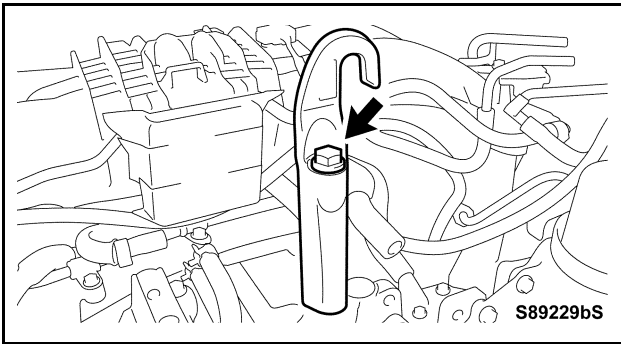

1. REMOVE ENGINE HANGER

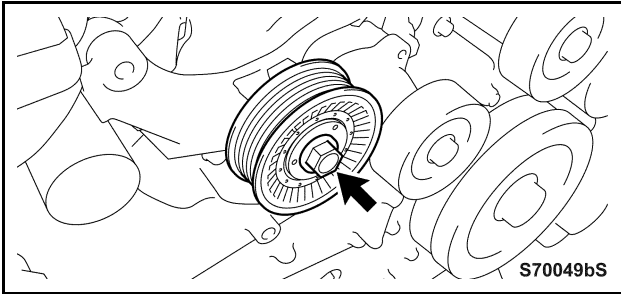

2. REMOVE NO. 2 IDLER PULLEY SUB-SSEMBLY

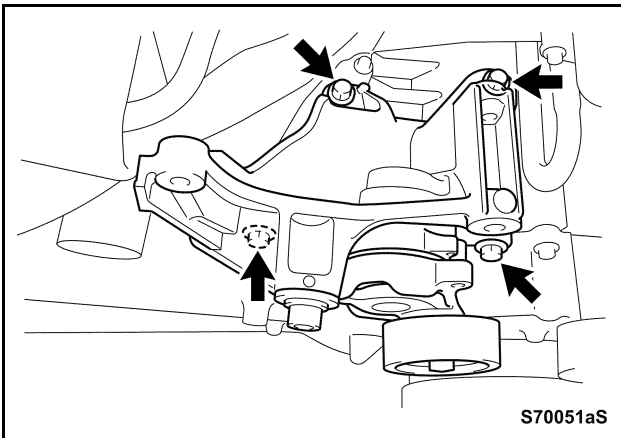

3. REMOVE V-RIBBED BELT TENSIONER ASSEMBLY

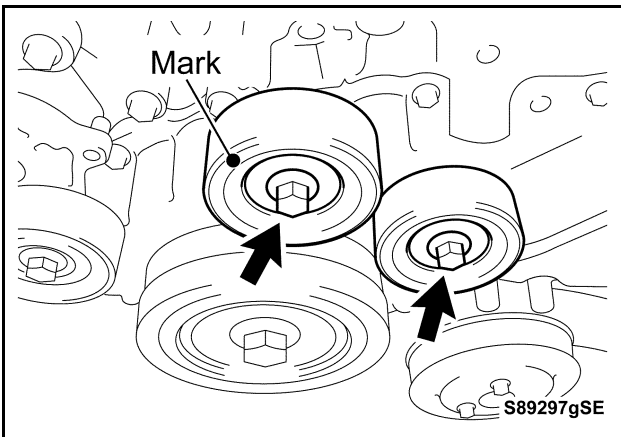

4. REMOVE NO. 1 IDLER PULLEY SUB-ASSEMBLIES

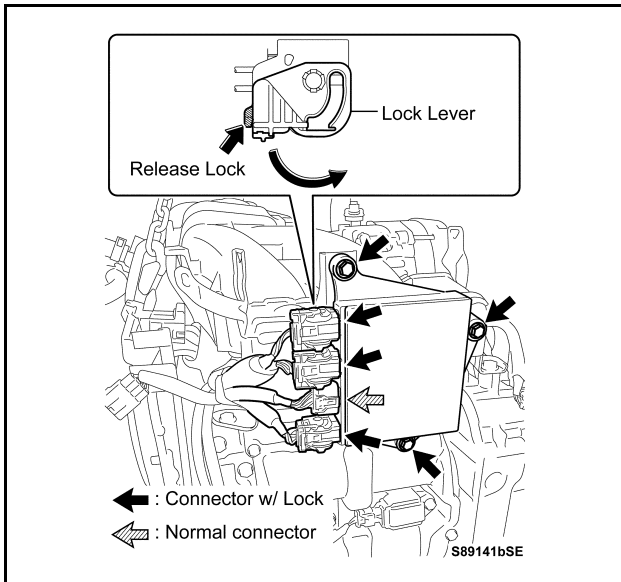

## 5. REMOVE INJECTOR DRIVER

- a) Disconnect the 3 connectors with lock, by releasing the lock and moving the lock lever in the direction shown in the illustration.
- b) Disconnect the normal connector.
- c) Remove the 3 bolts and the injector driver.



**DO NOT** use impact tools to remove the injector driver.

## 6. REMOVE INJECTOR COVER

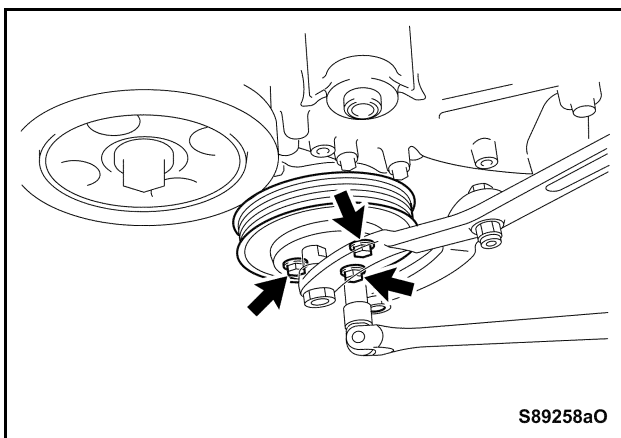
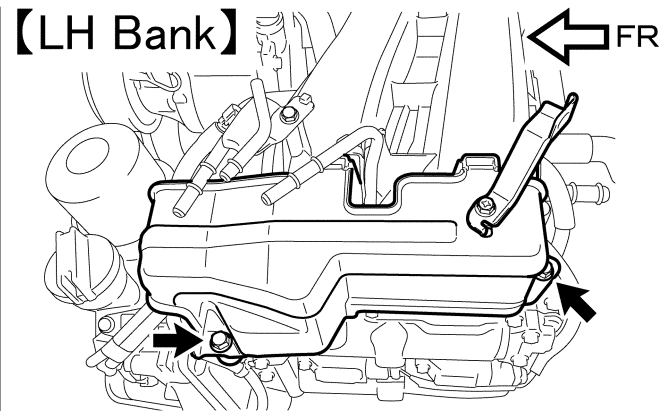
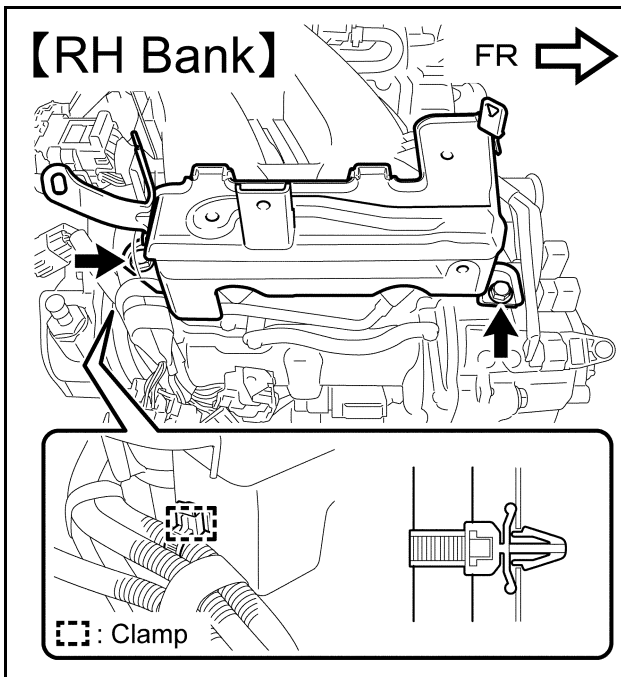

## 7. REMOVE WATER PUMP PULLEY

- a) Using SST, hold the water pump pulley in place.  
**SST : 09960-10010**  
**(09962-01000, 09963-00700)**
- b) Remove the 3 bolts and the water pump pulley.



Firmly hold **SST** and **DO NOT** allow it to detach from the pulley during removal.

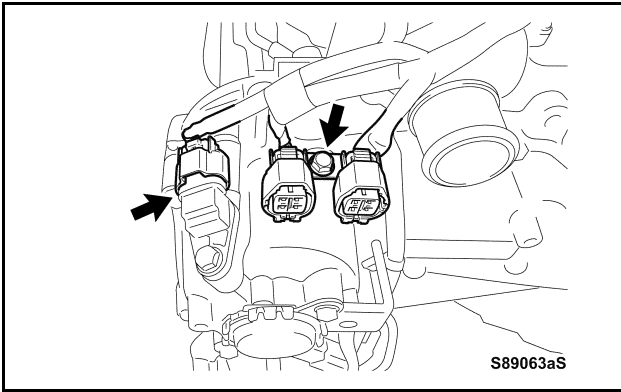

## 8. SEPARATE ENGINE WIRE

- a) Remove the bolt and disengage the wire harness clamp bracket.
- b) Disconnect the connector.

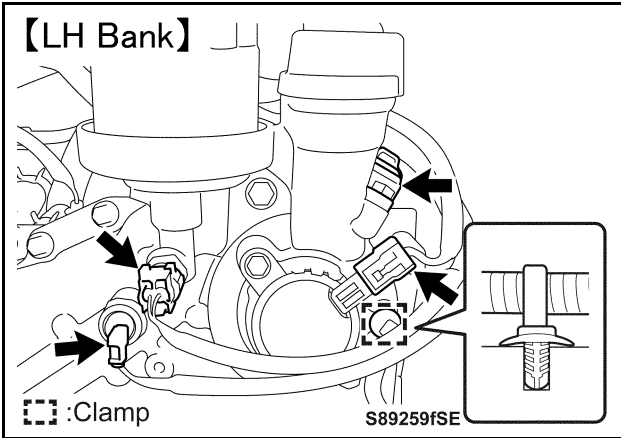

- c) Disconnect the 4 connectors.
- d) Detach the clip.

- e) Disconnect the 5 connectors.

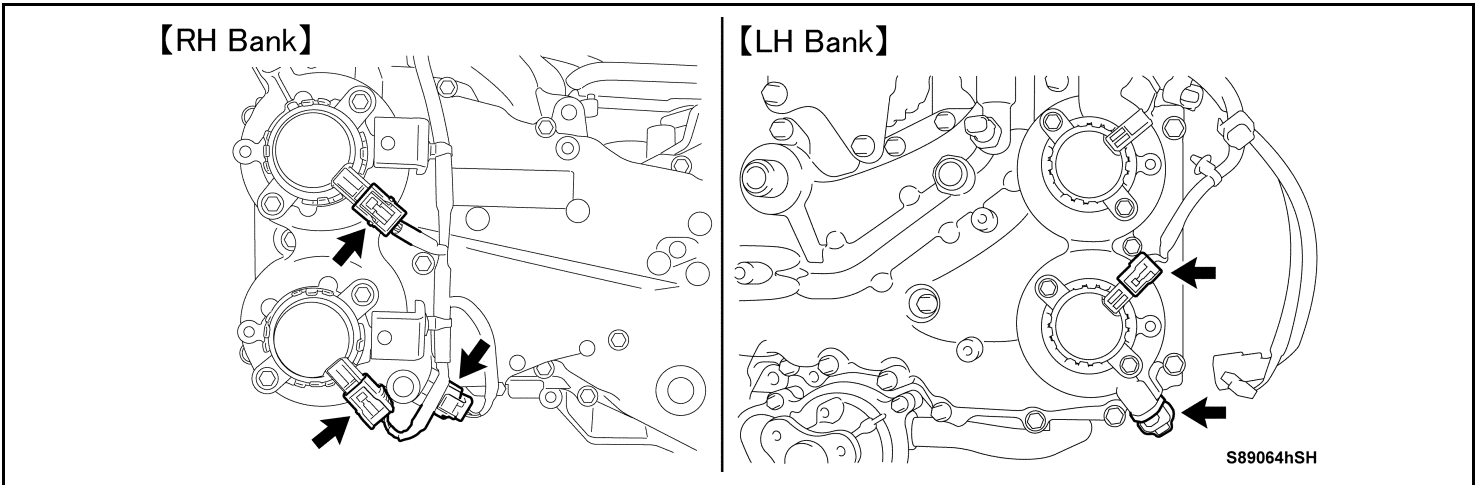

## 9. REMOVE CRANKSHAFT PULLEY

- a) Attach the crank pulley tool to the crankshaft pulley.



**Be sure to attach the tool with its claws set in the proper orientations.  
(When loosening the nut, the claws must engage with the pulley.)**

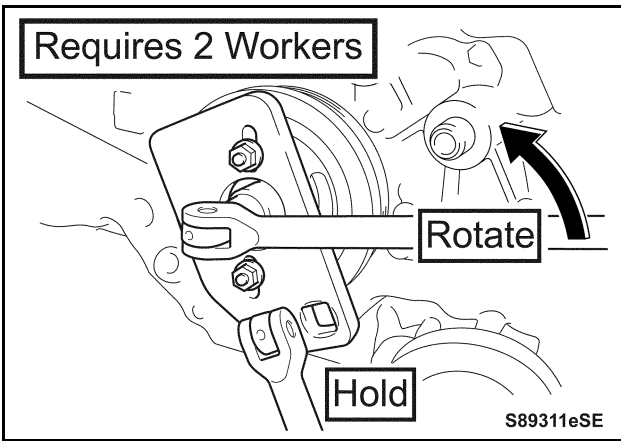
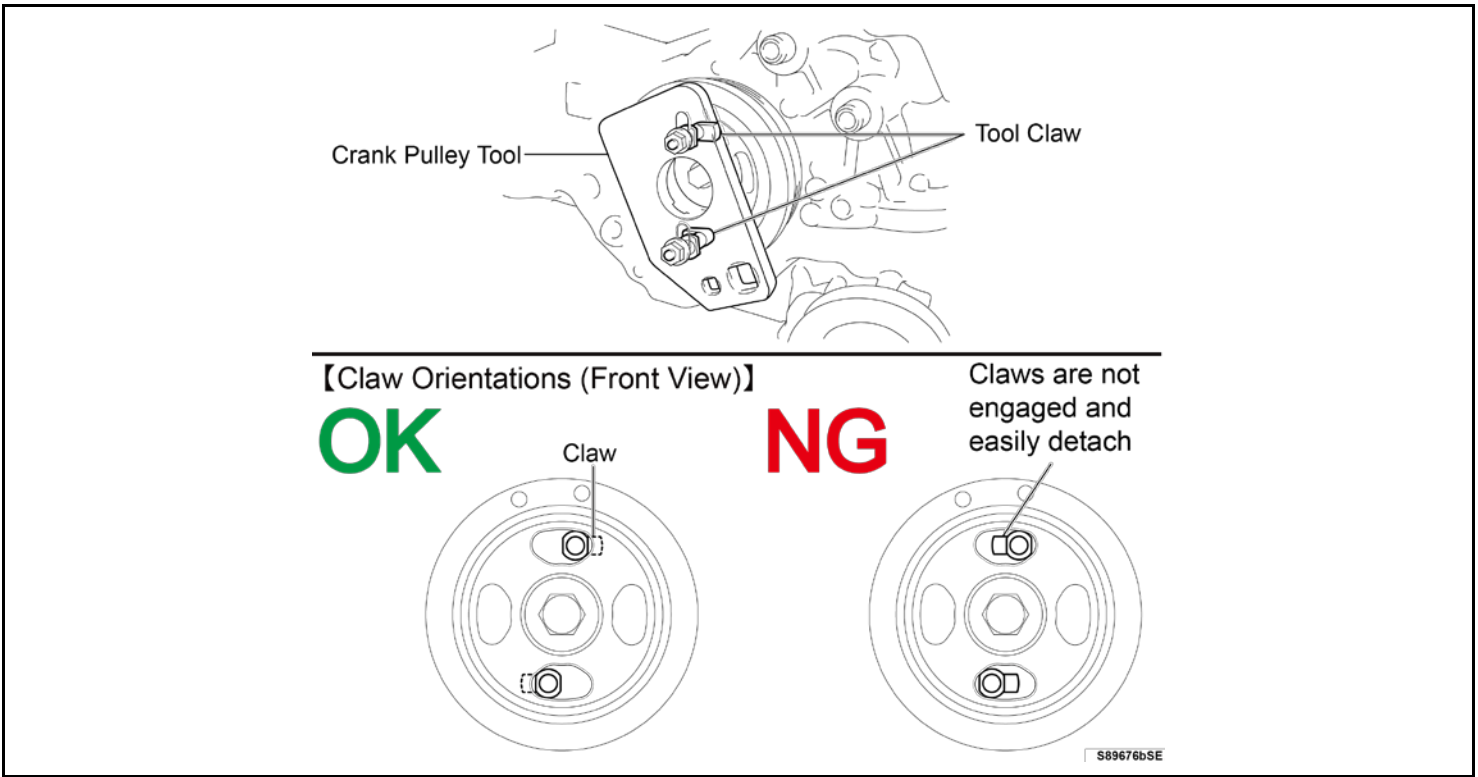

- b) While another worker holds the crankshaft pulley in place, remove the bolt.

**STOP**

**Be sure to firmly hold the crankshaft pulley while removing the bolt. The bolt is tightened to a high torque of approximately 184 ft.\*lbf (250 N\*m, 2549 kgf\*cm) or higher.**

- c) Remove the crankshaft pulley.

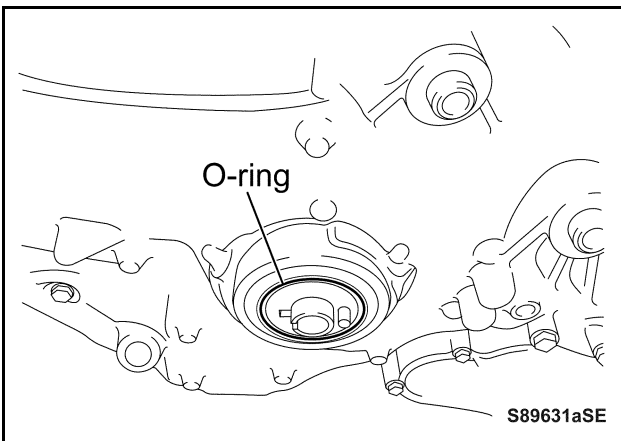

**10. REMOVE CRANKSHAFT PULLEY SPACER**

- a) Remove the O-ring.

**NOTE:**

**The O-ring may detach together with the crankshaft pulley.**

- b) Remove the O-ring, destroy and then store it in a separate container so as not to reinstall it in error.

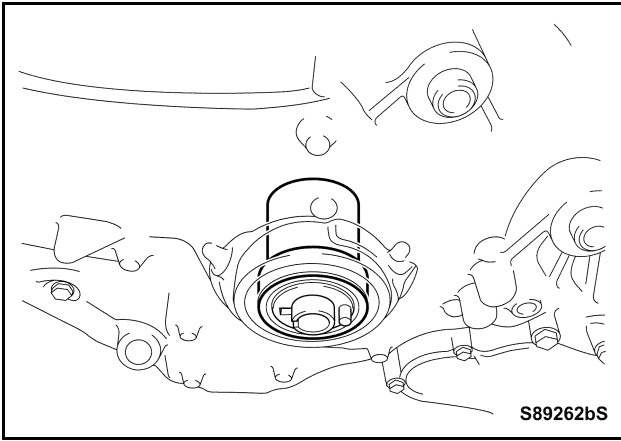

c) Remove the crankshaft pulley spacer.

**NOTE:**

**If the crankshaft pulley spacer cannot be removed by hand, use pliers wrapped in cloth to pull it out.**

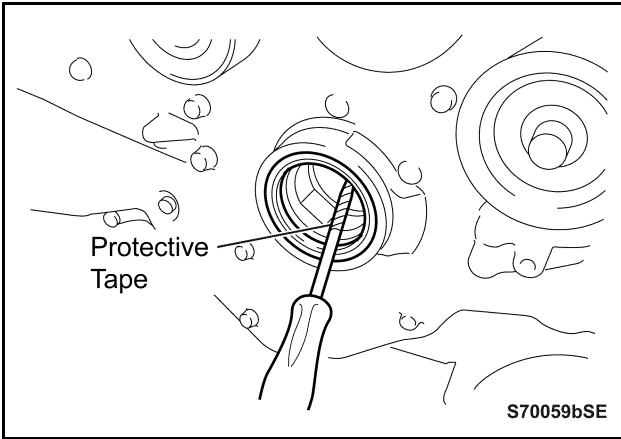

**11. REMOVE TIMING CHAIN OR BELT COVER OIL SEAL**

- a) Using a flathead screwdriver with its tip wrapped in protective tape, remove the timing chain or belt cover oil seal.
- b) Mark and store the removed oil seal in a separate container so as not to reinstall it in error.

## 12. REMOVE TIMING CHAIN OR BELT COVER SUB-ASSEMBLY

- a) Place a tray under the timing chain or belt cover sub-assembly to catch the oil that will come out from the engine.
- b) Remove the 32 bolts.
- c) Wear protective glasses while prying to remove the timing chain or belt cover sub-assembly, to prevent injuries by a damaged component or screwdriver.

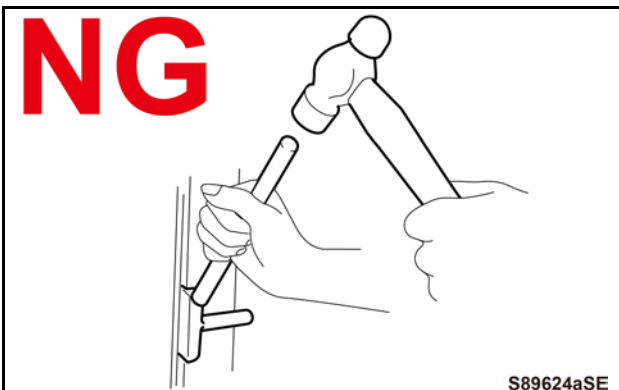
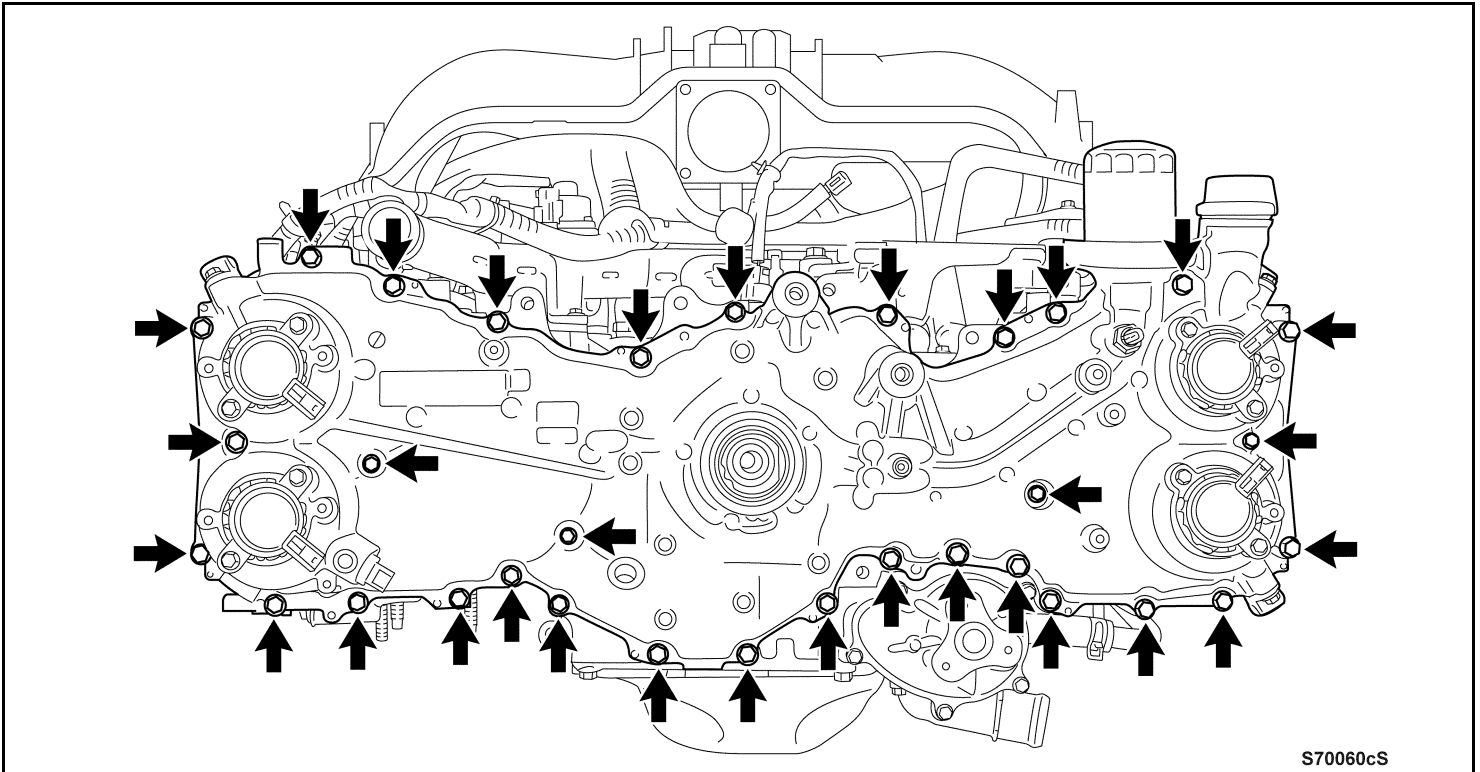

**DO NOT** use a seal cutter, or it may contact the components inside and cause damage.

d) Using a large flathead screwdriver with its tip wrapped in protective tape, pry the timing chain or belt cover sub-assembly in the 6 locations specified in the illustration to remove it.



- **DO NOT** damage the timing chain or belt cover sub-assembly, the cylinder head, the cylinder block or the components directly inside the timing chain or belt cover sub-assembly.
- **DO NOT** excessively pry at one location, or damage to the components may occur.

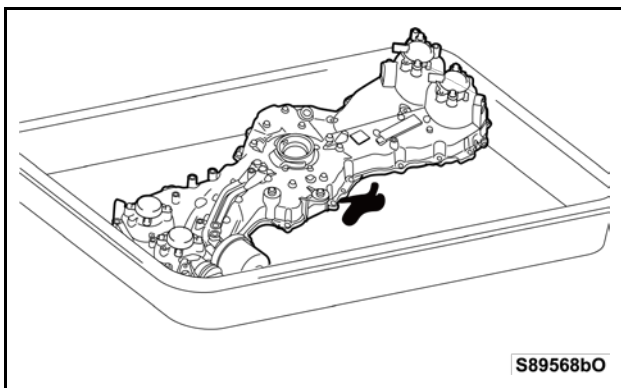
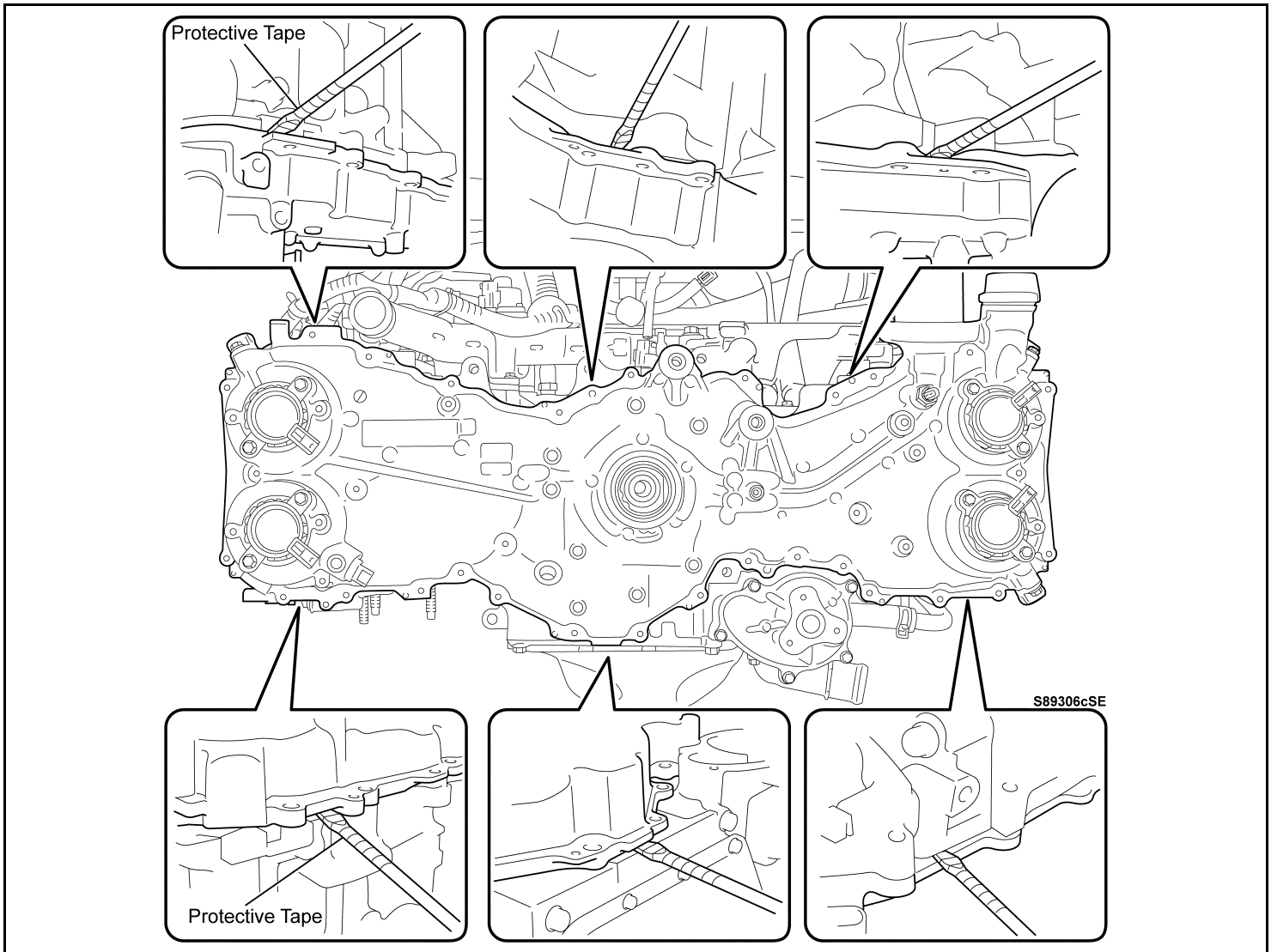

e) Place the removed timing chain or belt cover sub-assembly on a tray with its installation surface facing downward to allow oil to flow out.



**Be sure to remove oil, or oil may drip during the reinstallation of the timing chain or belt cover sub-assembly, and cause improper adhesion of seal packing.**

- f) Using a flathead screwdriver with its tip wrapped in protective tape, remove the 4 O-rings.
- g) Destroy the removed 4 O-rings, and then store them in a separate container so as not to reinstall them in error.

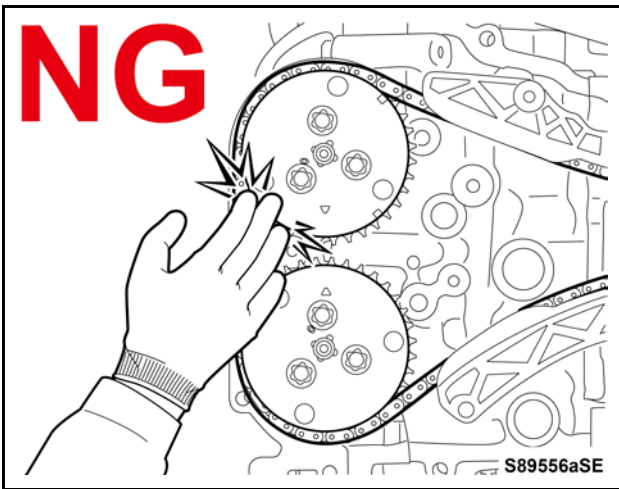
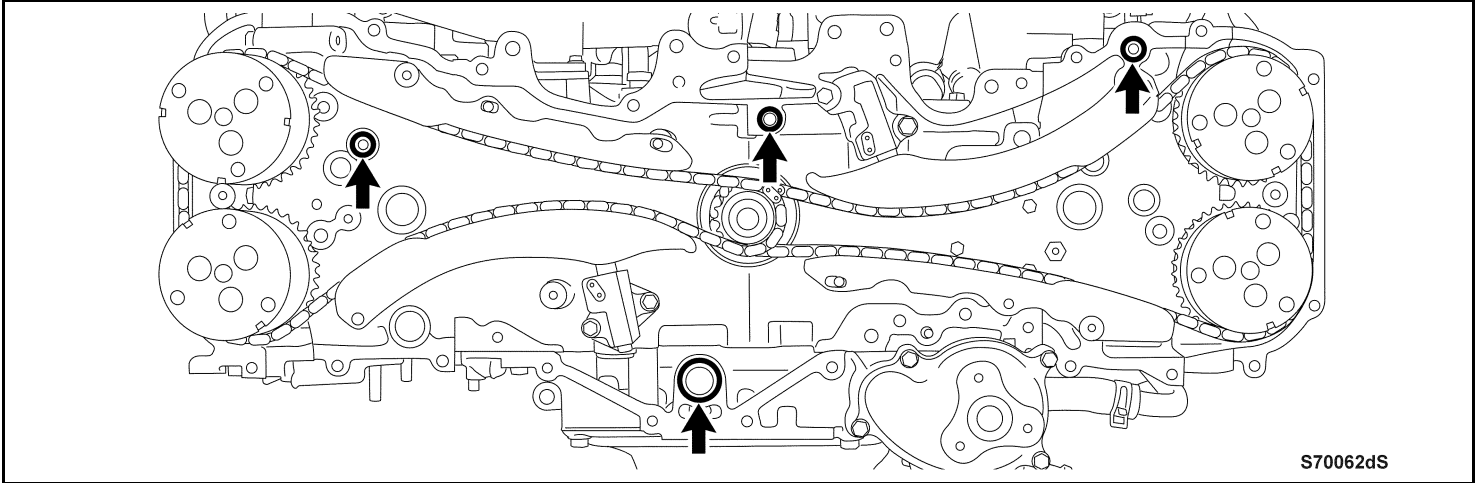

### 13. REMOVE CHAIN SUB-ASSEMBLY (for RH Bank)



- Be sure to work on one bank at a time to remove the chain assembly as instructed, with the camshafts set to zero lift or stopped with a balanced lift.
- **DO NOT** work on the chain without properly setting the camshaft lift positions or remove it from both banks at the same time. The camshafts may suddenly rotate strongly due to the tension of the springs.



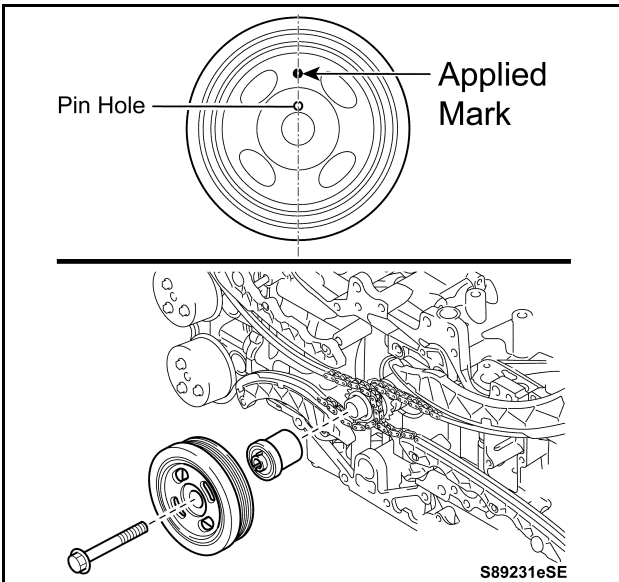

- a) Apply a mark on the outer portion of the crankshaft pulley, for checking the pin position from outside in a later procedure, to adjust the pulley position.
- b) Temporarily install the crankshaft pulley spacer, the crankshaft pulley and the bolt.

- c) Using SST, rotate the crankshaft pulley clockwise until the alignment marks on the camshaft timing intake gear assembly and the camshaft timing exhaust gear assembly, and the applied mark on the crankshaft pulley are all set in the positions shown in the illustration (The camshafts on the RH Bank are set to zero lift positions.)

**SST : 09960-10010 (09962-01000, 09963-01000)**

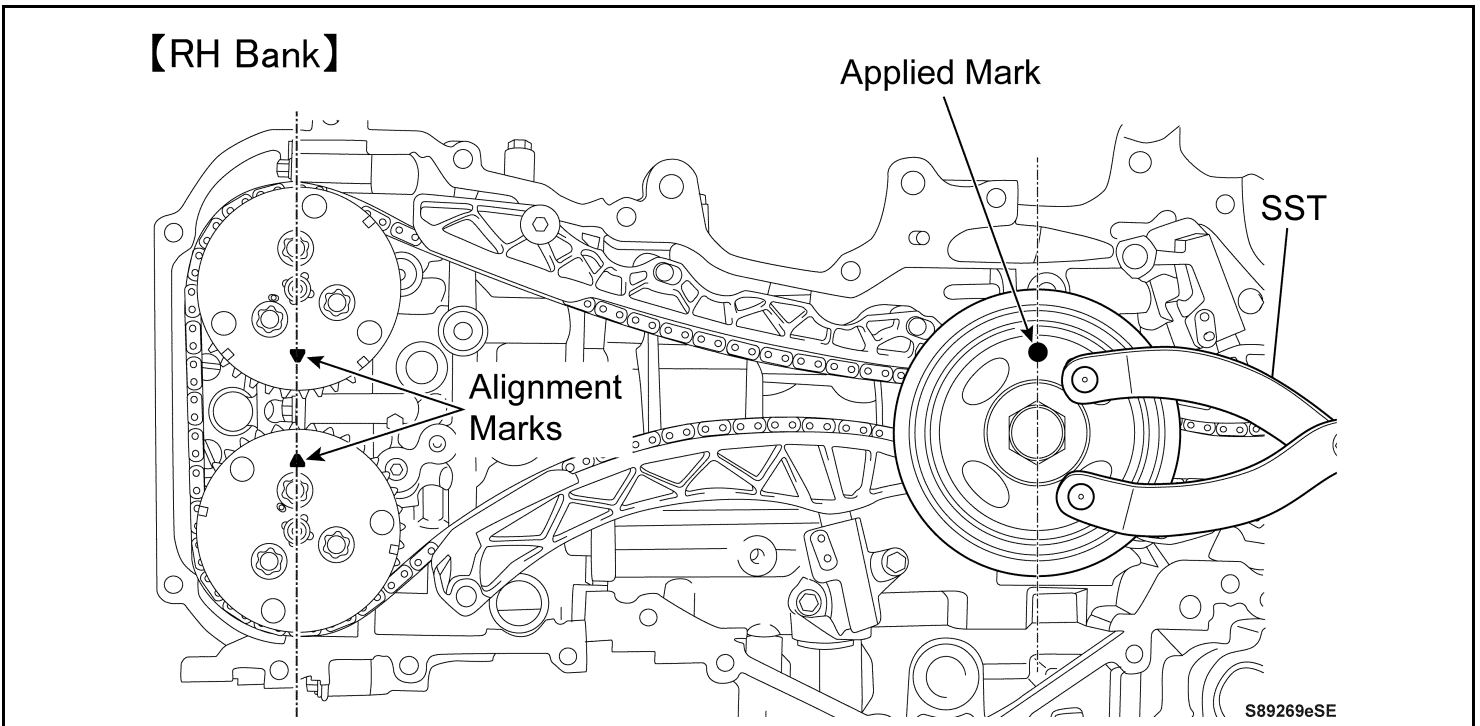

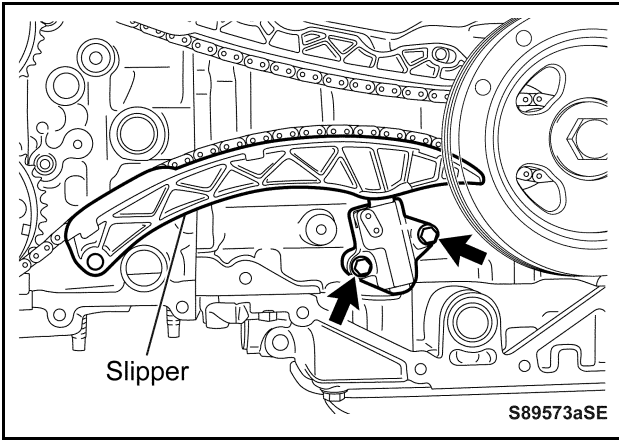

- d) Remove the 2 bolts and the No. 1 chain tensioner assembly.
- e) Loosen the chain and remove the chain tensioner slipper.

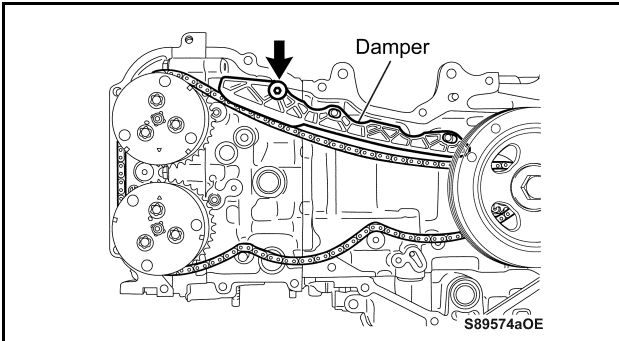

- f) Using a 5 mm (0.2 in.) hexagon socket, remove the bolt.
- g) Slide the chain to loosen it and remove the No. 1 chain vibration damper.

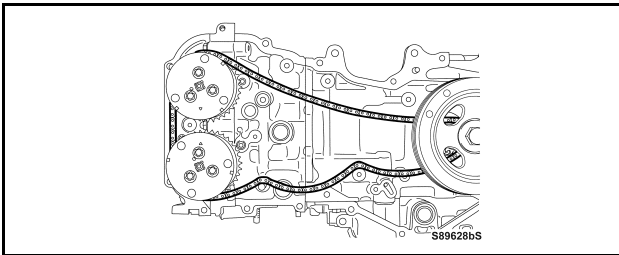

- h) Remove the chain from the RH Bank.
- i) Store the parts removed from the RH Bank in order (separate from the parts removed from the LH bank), so that they can be reinstalled to their original locations.



**DO NOT rotate the crankshaft or the camshaft after removing the chain sub-assembly, unless instructed to do so in this manual. Damage to components may occur due to interferences between pistons and valves, or between intake and exhaust valves.**

**NG** Interference between valve and piston

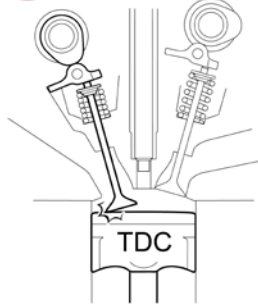

**NG** Interference between valves

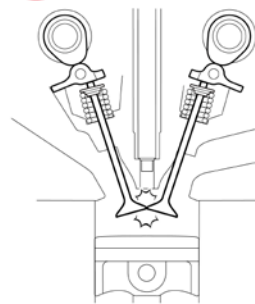

S89582aSE

#### 14. REMOVE CHAIN SUB-ASSEMBLY (for LH Bank)

- a) Using SST, rotate the crankshaft pulley clockwise until the alignment marks on the camshaft

timing intake gear assembly and the camshaft timing exhaust gear assembly, and the applied mark on the crankshaft pulley are all set at the positions shown in the illustration. (Be sure to precisely match the applied mark on the crankshaft pulley with the guide pin.)

**NOTE:**

- All camshafts on the LH bank are not set to zero lift positions as the camshafts on the RH bank are. The intake camshaft, shown in the upper right hand section in the illustration is stopped because the cam lobe lifts are balanced.
- On the intake camshaft on the LH bank, not only the cams for valve springs but also the cam for the fuel pump are provided. Thus there is no position of the intake and exhaust camshafts where both camshafts can be set to zero lift positions at the same time.

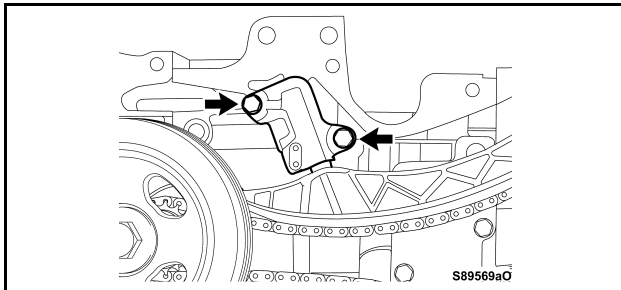
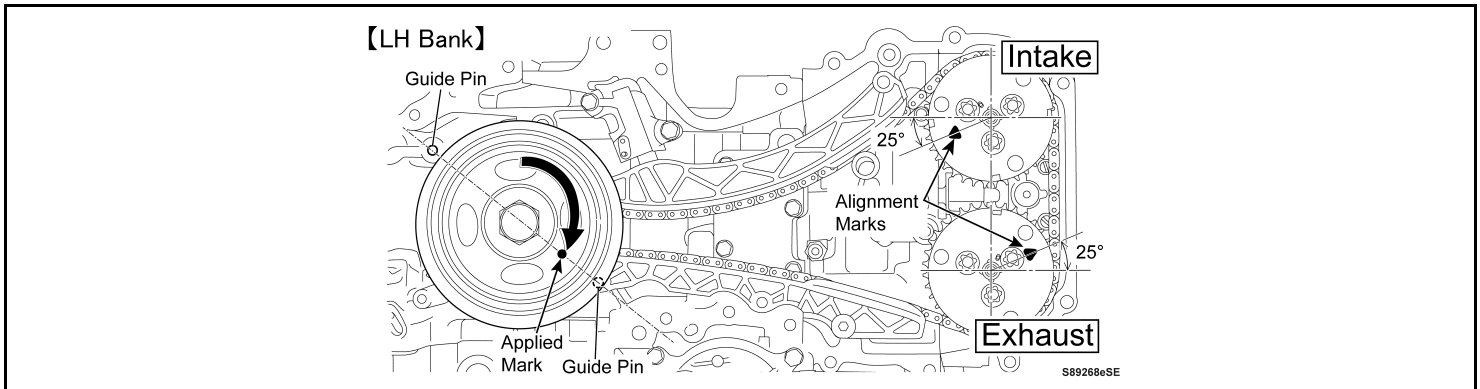

- b) Remove the 2 bolts and the No. 1 chain tensioner assembly.

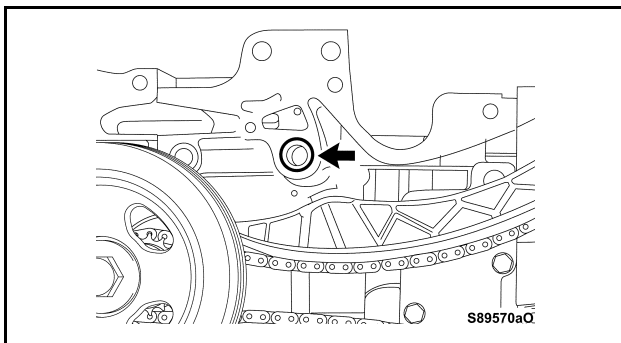

- c) Remove the O-ring.
- d) Destroy the removed O-ring, and then store it in a separate container so as not to reinstall it in error.

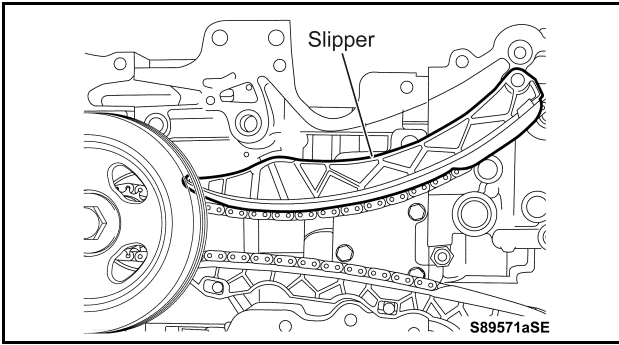

e) Remove the chain tensioner slipper.

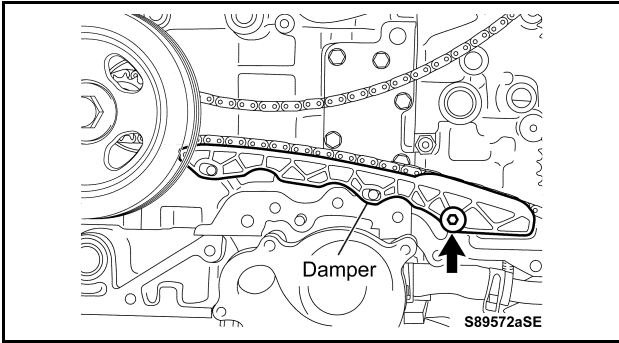

f) Using a 5 mm (0.2 in.) hexagon socket, remove the bolt.

g) Loosen the chain sub-assembly and remove the No. 1 vibration damper.

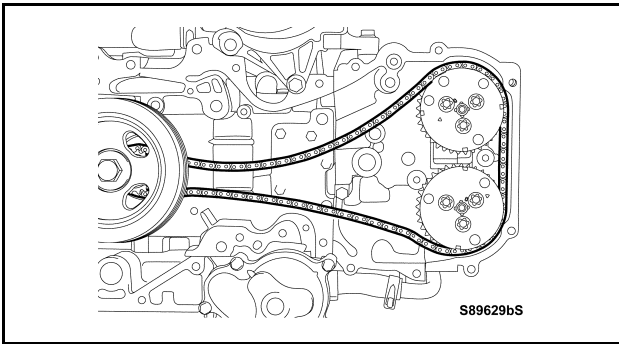

h) Remove the chain sub-assembly.

i) Store the parts removed from the LH Bank in order (separate from the parts removed from the RH bank) so that they can be reinstalled to their original locations.

## X. REMOVAL OF CYLINDER HEAD COVER (RH BANK)

### 1. SET INTAKE CAMSHAFT ON LH BANK TO ZERO LIFT POSITION

#### NOTE:

The intake camshaft is stopped not because it is set to zero lift position, but just because the cams are set to balanced lift positions. (The exhaust camshaft has already been set to zero lift position.)

If the intake camshaft is not set to zero lift when removing it, excessive force may be applied to it and the camshaft caps, and cause problems.

a) Using SST, rotate the crankshaft approximately 200 degrees clockwise until the applied mark on the crankshaft pulley comes to the top (all pistons are at the same height).



**DO NOT rotate the crankshaft counterclockwise, as the piston in cylinder No. 4 moves upward and cause damage due to interference between the valve and the piston.**

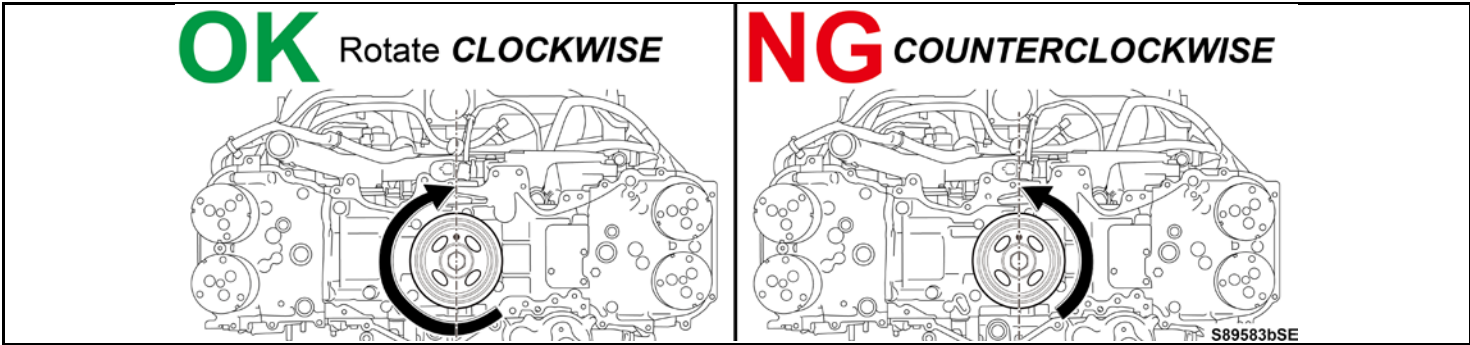

b) Remove the bolt, the crankshaft pulley and the crankshaft spacer.



c) Be sure to use the following instructions to set the intake camshaft to zero lift.

**STOP** **DO NOT touch the gear directly by hand, as the camshaft may make abrupt movement due to the increased tension on the valve springs and the fuel pump.**

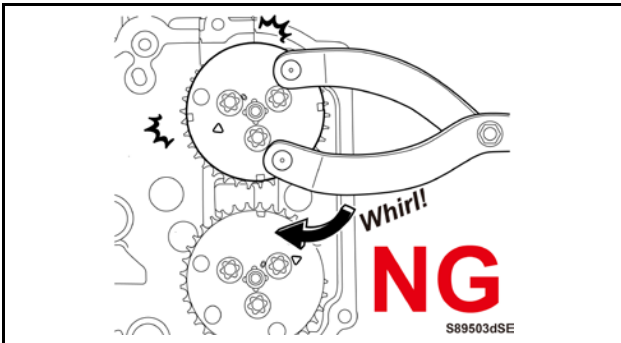

**STOP** **Be careful when rotating the camshaft using SST, as the camshaft may suddenly rotate strongly due to the cam for the fuel pump.**

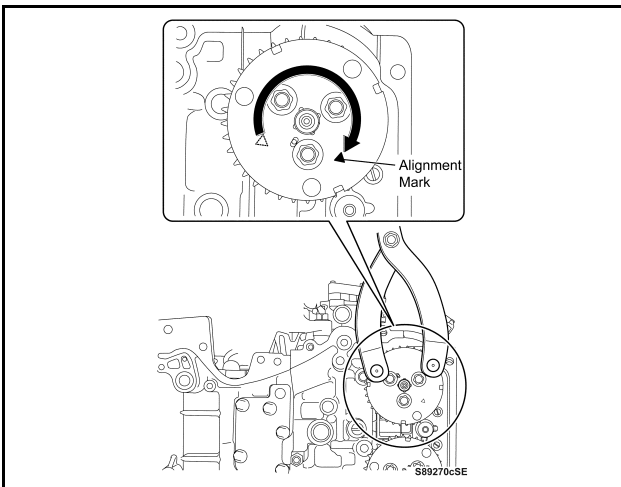

d) Using SST, rotate the intake camshaft on the LH bank clockwise until it comes to the position shown in the illustration (until it naturally stops). (The camshaft is set to zero lift position.)

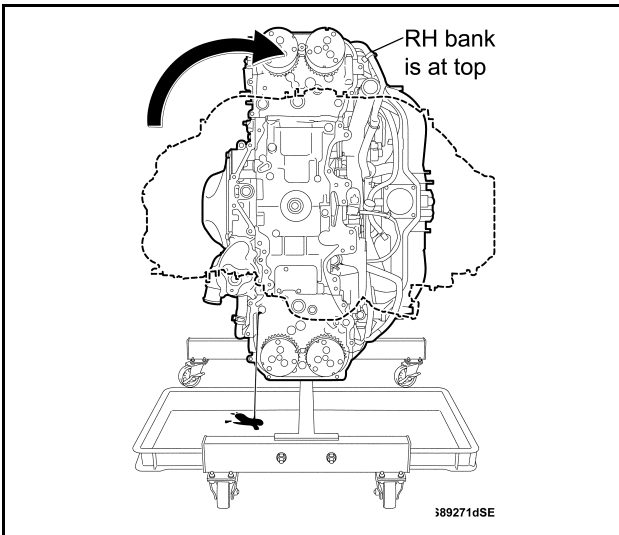

## 2. REMOVE IGNITION COIL ASSEMBLY

[for RH Bank (Cylinders No. 1 and No. 3)]

- a) Rotate the engine stand until the RH bank comes to the top.

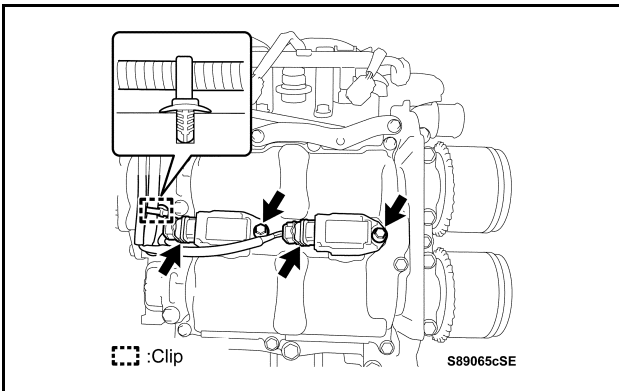

- b) Disconnect the 2 connectors and detach the clip.
- c) Remove the 2 bolts and the 2 ignition coils.

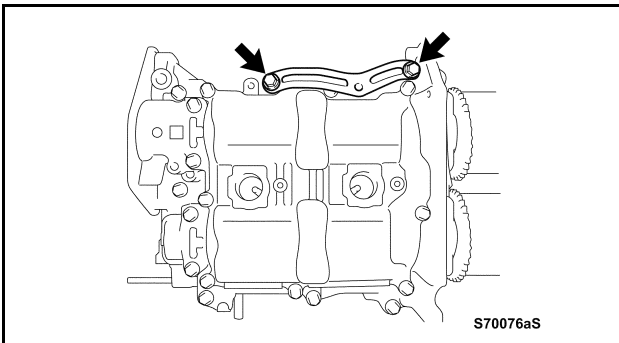

## 3. REMOVE INJECTOR DRIVER BRACKET

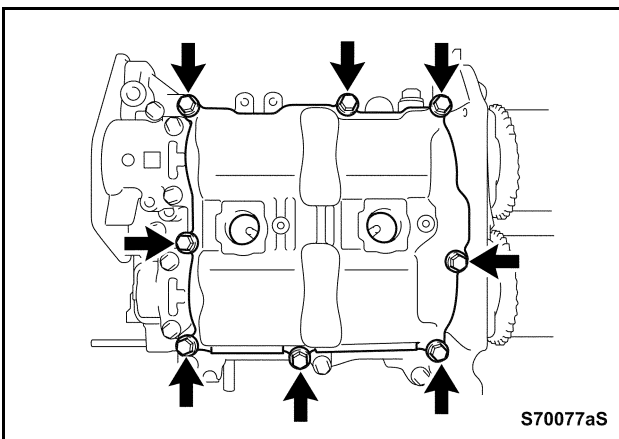

## 4. REMOVE CYLINDER HEAD COVER SUB-ASSEMBLY RH

- a) Remove the 8 bolts.

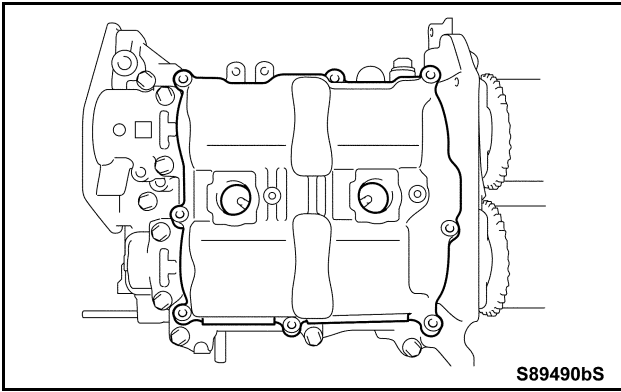

- b) Remove the cylinder head cover sub-assembly RH (partially adhered with seal packing) by hand.



**DO NOT use any tools, or damage to the contact surfaces may occur.**

- c) Remove the gasket.
- d) Destroy the removed gasket, and then store it in a separate container so as not to reinstall it in error.

## XI. REMOVAL OF CAMSHAFTS (RH BANK)

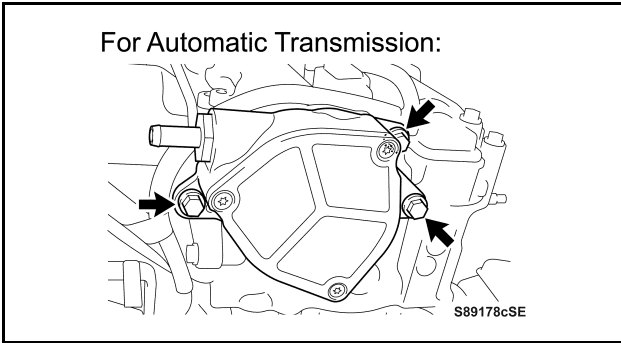

### 1. REMOVE VACUUM PUMP ASSEMBLY (for Automatic Transmission)

- a) Remove the 3 bolts.

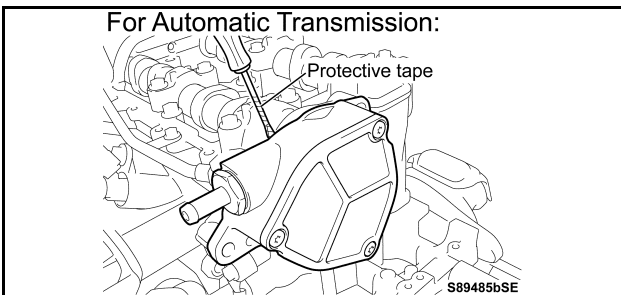

- b) Using a flathead screwdriver with its tip wrapped in protective tape, pry the vacuum pump assembly adhered with seal packing to remove it.



**Be careful not to damage the contact surfaces with the tool.**

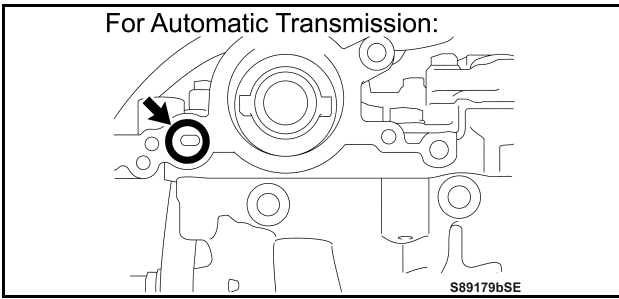

- c) Remove the O-ring.
- d) Destroy the removed O-ring, and then store it in a separate container so as not to reinstall it in error.

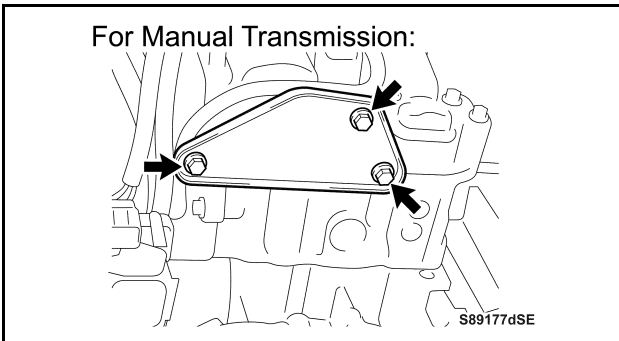

**2. REMOVE REAR CYLINDER HEAD PLATE (for Manual Transmission)**

- a) Remove the 3 bolts.

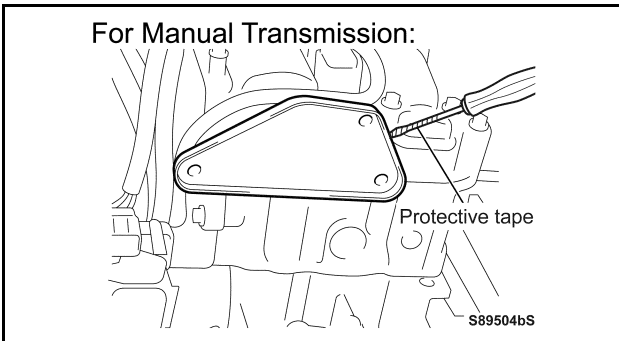

- b) Using a screwdriver with its tip wrapped in protective tape, pry the rear cylinder head plate to remove it.

**STOP** *DO NOT damage the contact surfaces or deform the plate with the tool.*

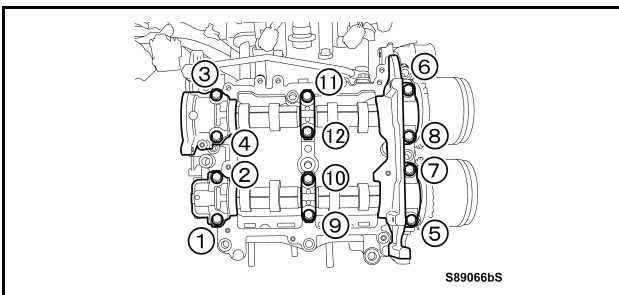

**3. REMOVE CAMSHAFT CAPS**

- a) Uniformly loosen the 12 bolts in the specified order in several passes, and remove the 12 bolts.

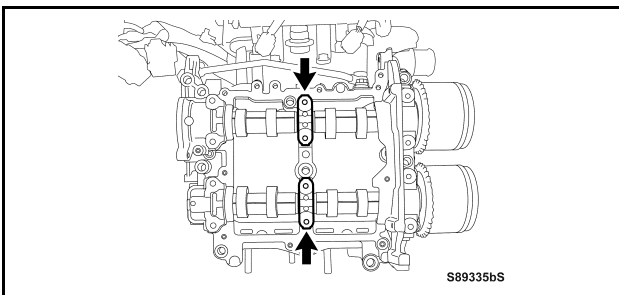

- b) Remove the 2 center camshaft caps.

- c) Using a flathead screwdriver with its tip wrapped in protective tape, pry the 3 camshaft caps, adhered with seal packing, to remove them.





Be careful not to damage the contact surfaces with the tool.

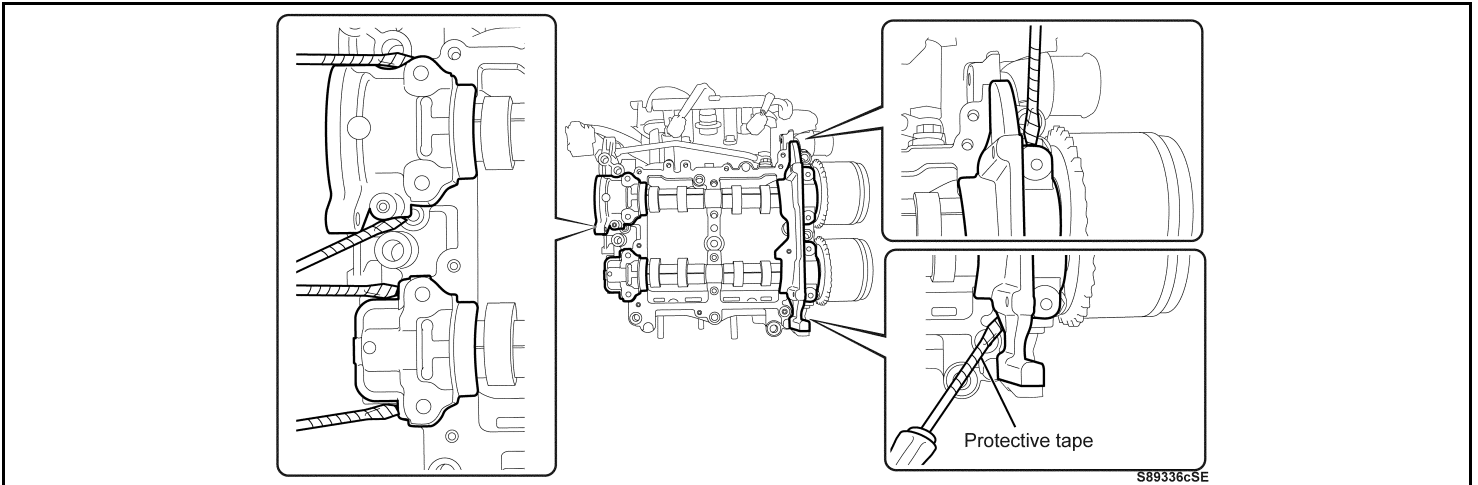

d) Store the removed parts in order so as to reinstall them to their original locations.

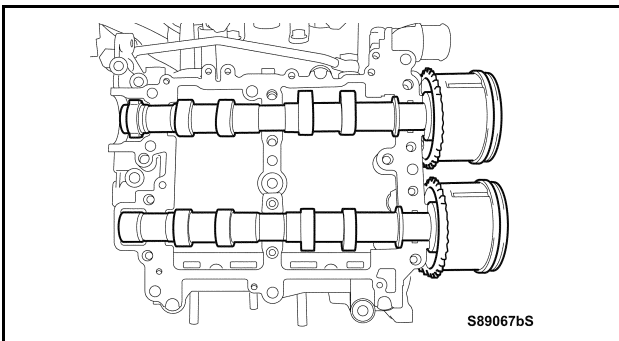

#### 4. REMOVE CAMSHAFTS

a) Remove the 2 camshafts.

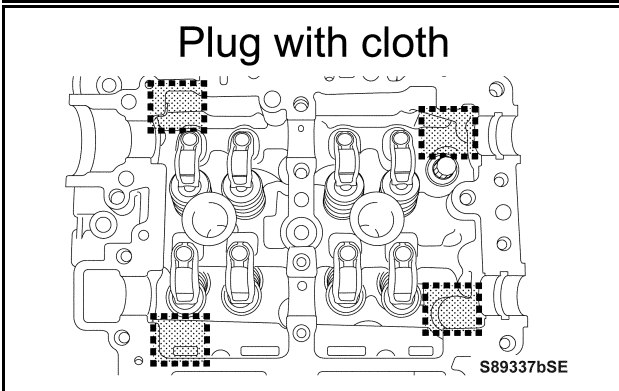

b) Plug the 4 oil holes with cloth to prevent any parts from dropping into them.

### [IMPORTANT] 6 TIPS TO PREVENT WORK ERRORS

#### 5. PREPARE PARTS TRAY FOR STORING VALVE ROCKER ARM SUB-ASSEMBLIES AND VALVE ADJUSTING SHIMS IN ORDER

a) All rocker arms and adjusting shims must be restored to their original locations. If not, the valve clearances may be disturbed and result in engine malfunctions. Be sure to store the removed components in order as shown, so that they can be restored to their exact original

locations.

[CLICK HERE TO WATCH A VIDEO ON ROCKER ARM ORGANIZATION](#)

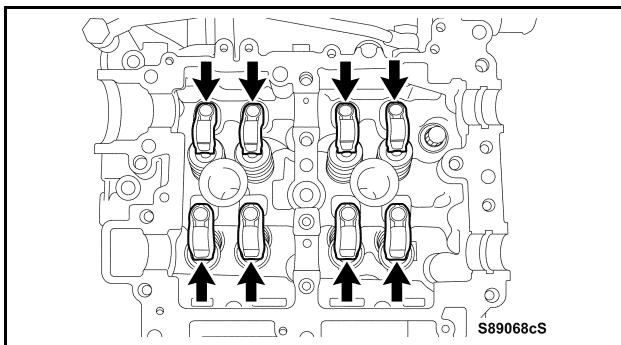
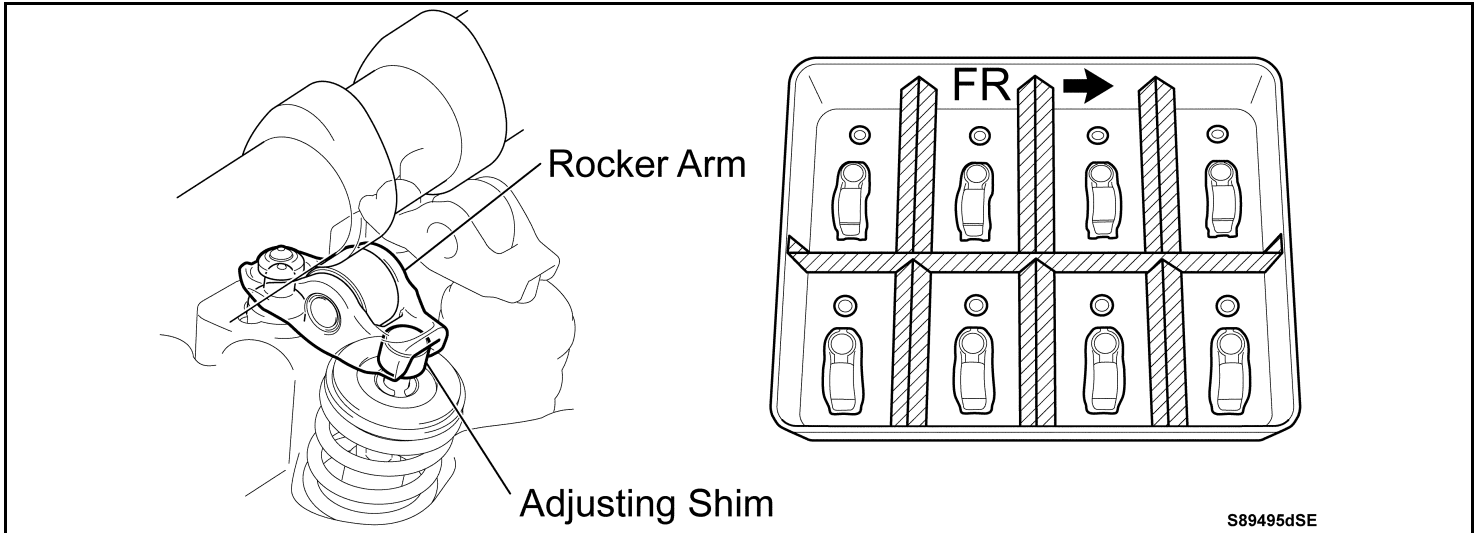

## 6. REMOVE VALVE ROCKER ARM SUB-ASSEMBLIES

- Remove and store the 8 rocker arms in order in the prepared parts tray, so that they can be reinstalled to their original locations.

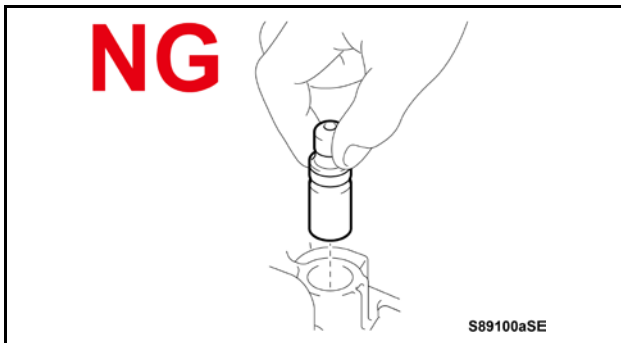

**DO NOT** remove the rocker arm pivot, or poor sliding performance may occur due to adhesion of foreign matter.

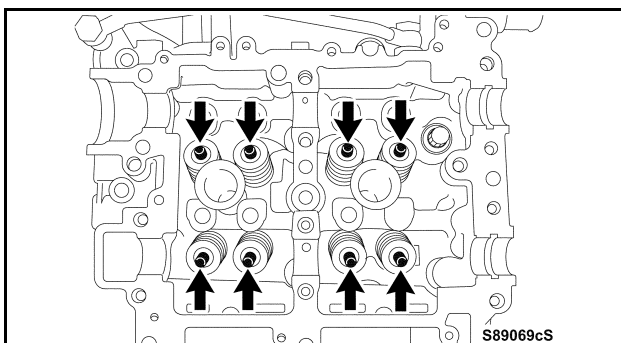

## 7. REMOVE VALVE ADJUSTING SHIMS

- Remove and store the 8 valve adjusting shims in order in the prepared parts tray, so that they can be reinstalled to their original locations.

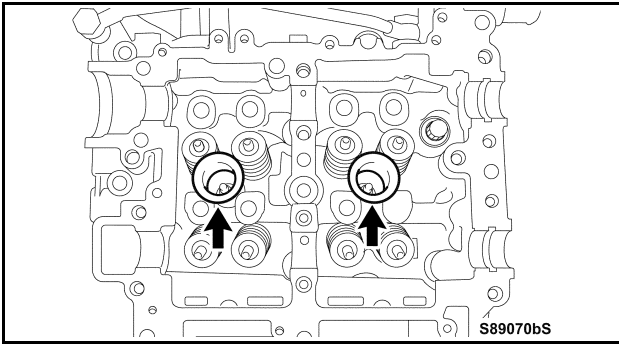

## 8. REMOVE SPARK PLUG TUBE GASKETS

- a) Remove the 2 spark plug tube gaskets.
- b) Destroy the removed 2 gaskets, and then store them in a separate container so as not to reinstall them in error.

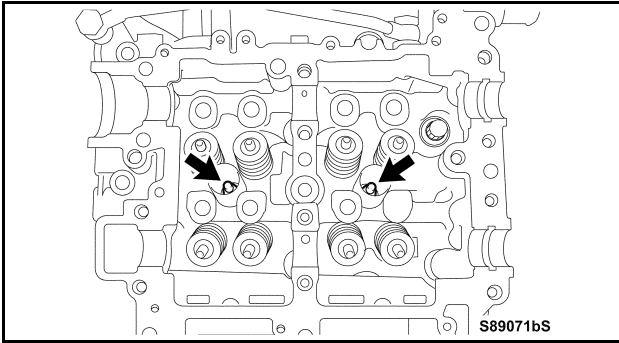

## 9. REMOVE SPARK PLUGS

- a) Using a 14 mm (0.55 in.) spark plug wrench, remove the 2 spark plugs.
- b) Store the removed 2 spark plugs in order in a separate parts tray, so that each can be restored to its original location.

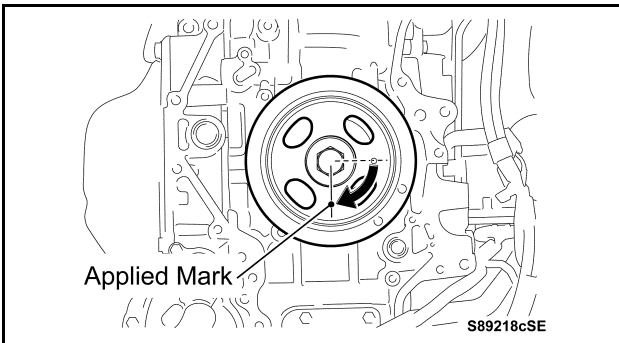

## 10. PREPARE FOR REPLACEMENT OF NO. 3 CYLINDER VALVE SPRINGS

- a) Temporarily install the crankshaft spacer, the crankshaft pulley and the bolt.
- b) Rotate the crankshaft 90 degrees clockwise until the applied mark on the pulley comes to the bottom as shown in the illustration (at the right side, when the engine is installed to the vehicle).

# XII. REPLACEMENT OF VALVE SPRINGS

# Copy And Display When Working

<Make copies for use>

■ Cylinders to which Pneumatic Pressure should be Applied and Cylinder in which Springs Can be Replaced (Replace the springs when that cylinder is set to TDC, to prevent the valves from dropping inside the cylinders.)

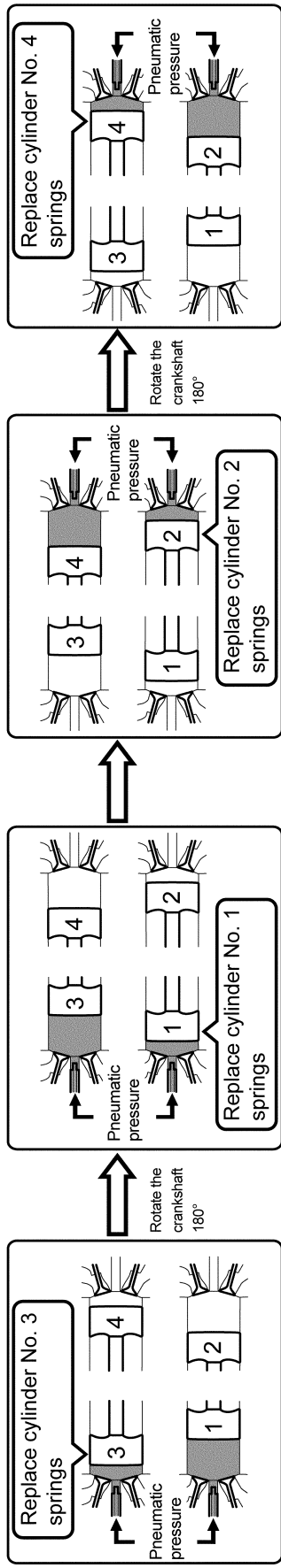

## ■ Spring Replacement Procedure Flow-chart

(Be sure to observe the instructions, or serious problems may occur due to the crankshaft being rotated by the pistons moved by the residual pressure inside air hoses.)

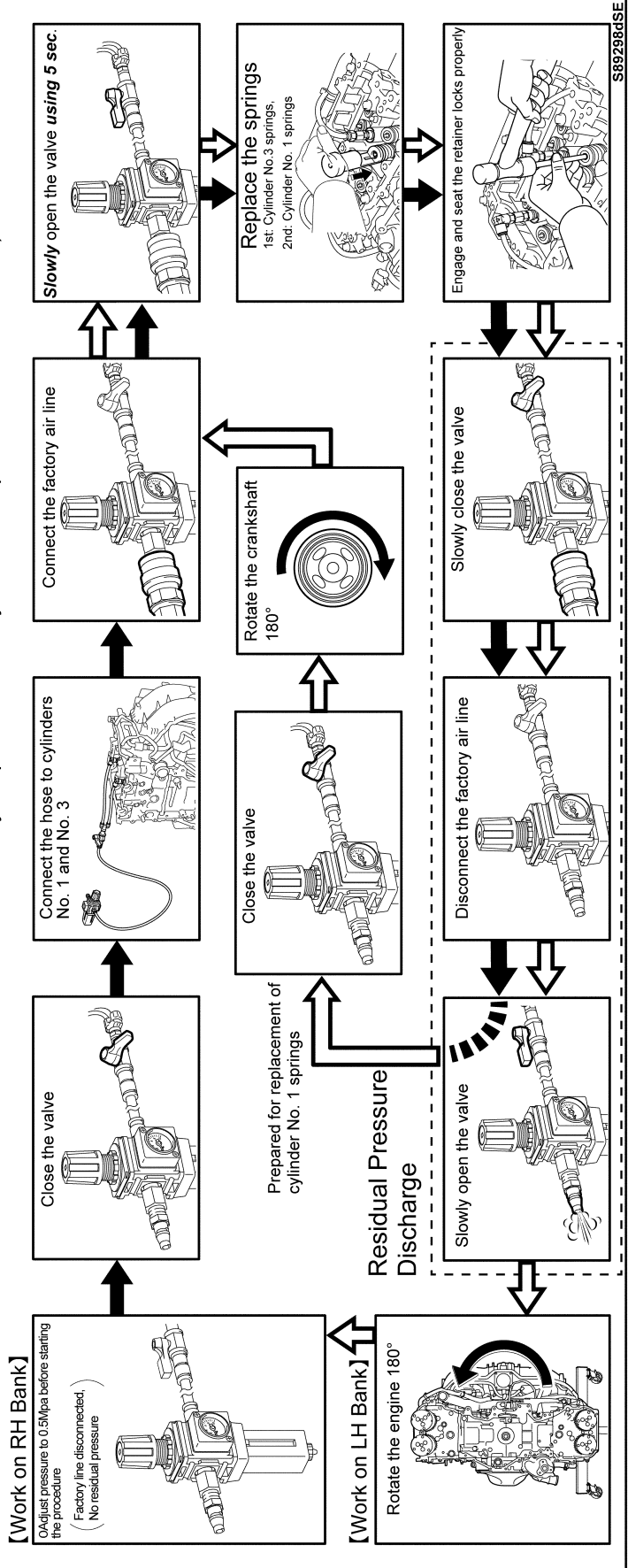

S89298dSE

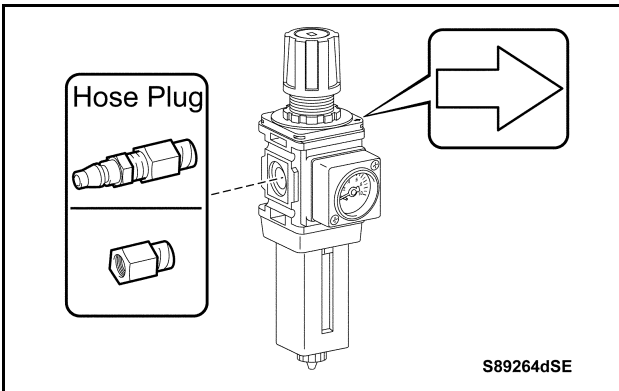

## 1. ASSEMBLE PRESSURE HOLDING TOOL

- a) Of the 2 hose plugs, install the one that can attach to the pressure regulator on the side without an arrow mark.



**DO NOT** over tighten the plug.

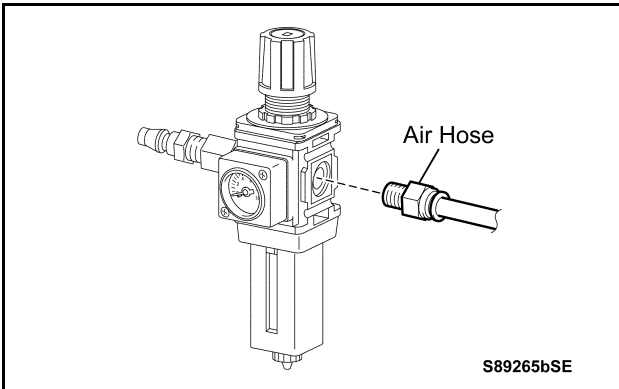

- b) Attach the air hose to the regulator.



**DO NOT** over tighten the hose.

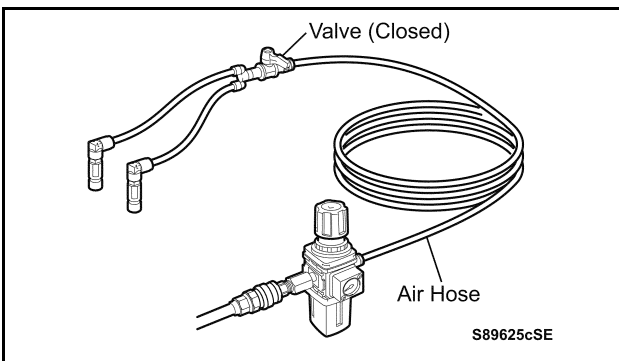

## 2. INSPECT, CLEAN AND ADJUST PRESSURE HOLDING TOOL

- a) Close the regulator valve, and connect the compressed air line to the regulator.



**DO NOT** apply pneumatic pressure higher than 145 psi (1.0 Mpa). Damage to the regulator may result by too high pressure.

- b) Pull the adjusting control knob upward to unlock, and adjust the pneumatic pressure to 0.5 Mpa (72.5 psi).
- c) Lock the adjusting control knob.

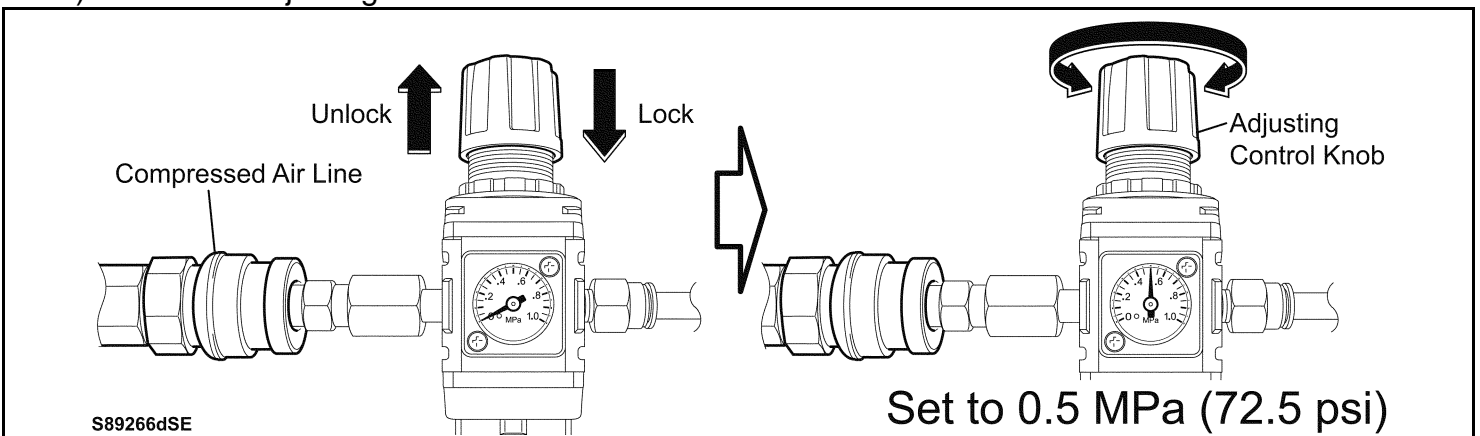

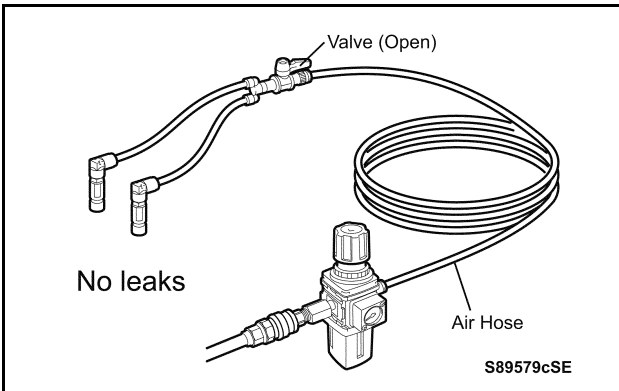

d) Open the valve, and check that there are no air leaks from any part.

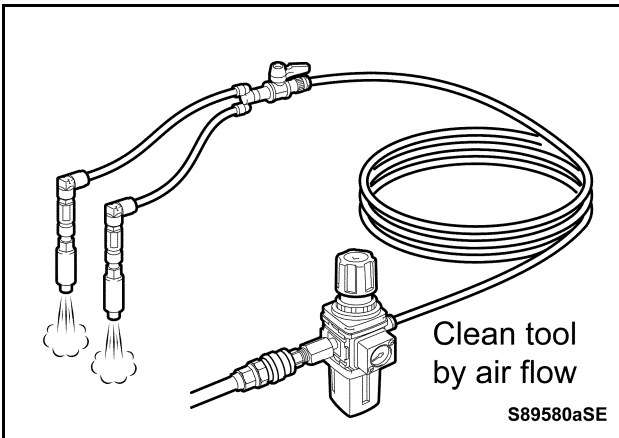

- e) Close the valve.
- f) Attach the 2 air adapters to the air hose.
- g) Open the valve to allow air to flow, and clean inside the air hose and the adapters.
- h) Detach the 2 air adapters from the air hose.

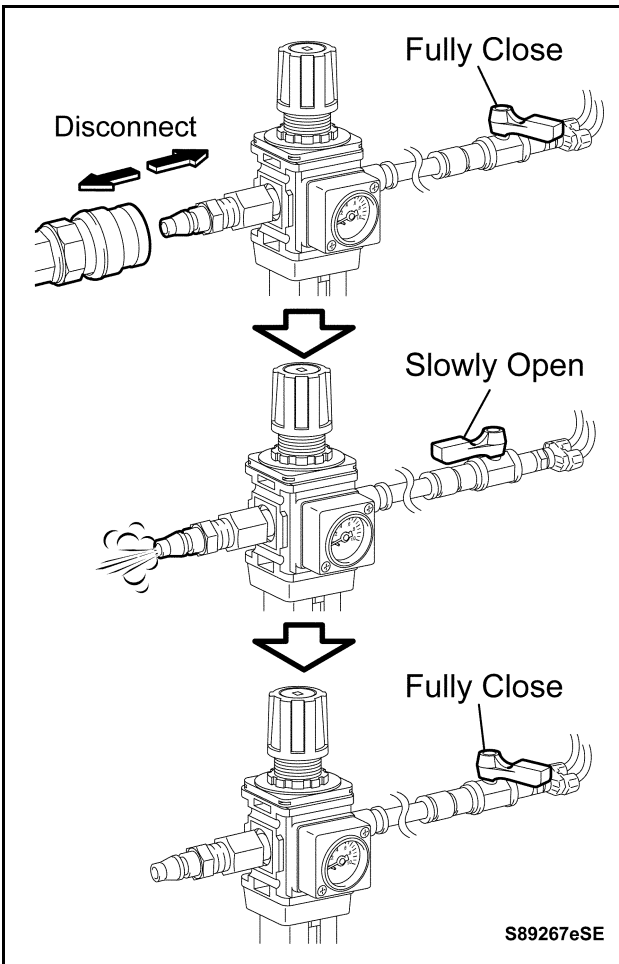

- i) Reset the air hose to the default condition.
  - 1) Close the valve.
  - 2) Disconnect the compressed air line from the regulator.
  - 3) Slowly open the valve to discharge all residual pressures.
  - 4) Close the valve.