

SAFETY RECALL

Mack Trucks Inc.
Greensboro, NC USA



Date	Number	Page
12/18	SC0414	1 (4)

Light Control Module, Reprogramming

SAFETY RECALL INFORMATION:

(December 2018)

Certain vehicles fitted with snow plow lamp prep-kits do not comply with U.S. and Canada Motor Vehicle Safety Standard 108, Lamps, reflective devices, and associated equipment. Specifically, snowplow headlamps can be turned on without other exterior lights on, and the high beam indicator does not work when snow plow high beams are on.

Potential risk includes vehicle may be operated with snow plow headlamps on and marker and tail lamps off. This is unlikely as the dash lights would not be on, which will warn the driver. This can only occur when snow plow lamps are on without the master lighting control switch on.

VEHICLES AFFECTED:

Mack: Certain 2019 Granite model vehicles manufactured from February 1, 2018 to October 23, 2018 with a snowplow prep-kit.

VEHICLE IDENTIFICATION NUMBERS (VIN):

The total number of vehicles affected is 851

DECOMMISSIONING THE TRUCK FOR REPAIR



Do not attempt to repair or service this vehicle without having sufficient training, the correct service literature and the proper tools. Failure to follow this could make the vehicle unsafe and lead to serious personal injury or death.

NOTE

The Illustrations shown in this document are used for reference only and may differ slightly from the actual vehicle being serviced. However, the replacement procedure is represented as accurately as possible.

1. Secure the vehicle for service by parking on a flat and level surface, applying the parking brake, chocking the rear wheel, and placing the transmission in neutral. Disconnect the cable from the battery's negative (ground) terminal.

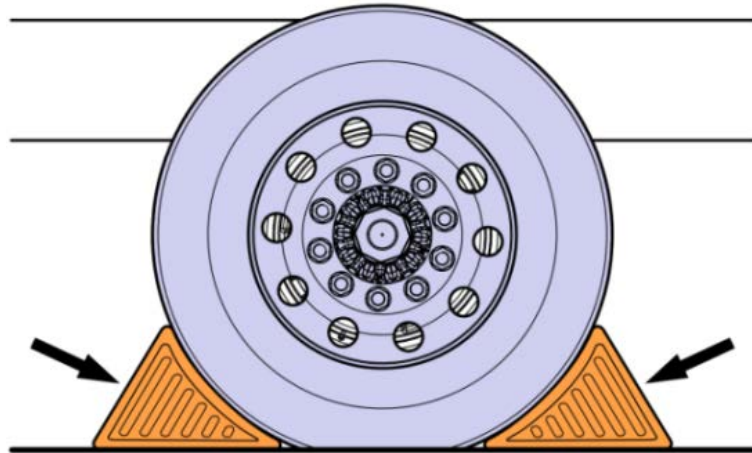

REPROGRAMMING PROCEDURE

2. Connect Premium Tech Tool to the vehicle.



3. Reprogram the Light Control Module
(MID 216, Operation 1700-08-03-39 Program Electronic Control Unit).
4. Disconnect Premium Tech Tool from the vehicle.
5. Check that the LCM is functioning properly by performing the following test:
 - a. Turn the snowplow switch on while the master light switch is kept turned off.
Check that the vehicle marker lights are illuminated.
 - b. Turn the snowplow switch on while the master light switch is also turned on, and activate the high beams. Check that the high beam tell-tale indicator light is illuminated in the instrument cluster.
6. Remove the wheel chocks.

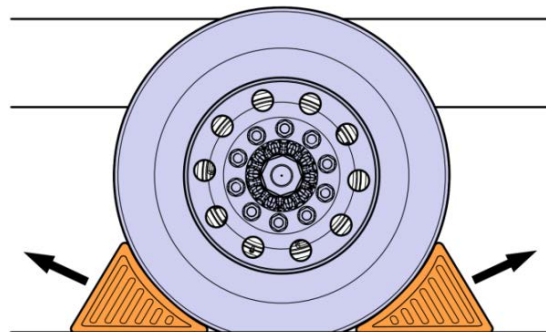

REIMBURSEMENT:

	UCHP Reimbursement
Claim Type (used only when uploading from the Dealer Business System)	R
Recall Status	
Vehicle repaired per instructions	1-Modified per instructions
Labor Code	
Primary Labor Code (Light Control Module, Reprogramming)	3651-22-09-03 0.7 hrs
Time to take charge of vehicle and determine campaign status	1700-16-01-01 0.3 hrs
Causal Part	23288977
Authorization Number	C6599

Take-charge time is not included in the labor code for this operation. Take charge may be eligible, but can only be used once per vehicle repair visit. If the vehicle is having other warranty repairs performed, take-charge should be charged to the warranty repair, otherwise take-charge can be charged to this Safety Recall campaign.