

AJ09 - Replacing Right Rear Seat-Belt Buckle (Stop Sale/Recall Campaign)

Model Line: **Cayenne (9YA)**

Model Year: **2019**

Subject: **Right rear seat-belt buckle**

Information: **Seat-belt buckles that do not meet the required specifications were installed for the right rear seat on the affected vehicles.**

As a result, the required restraint function cannot be guaranteed in the event of a head-on collision.

Remedial Action: Replace right rear seat-belt buckle.

Affected Vehicles: Only the vehicles assigned to the campaign (see also PIWIS Vehicle information). This campaign affects 415 vehicles in North America.

Parts required

Parts Info: **Please Note: Dealers will receive a limited initial allocation of the required AJ09 parts. Once additional parts become available, a second allocation of roughly 50% will be delivered to dealers. After second allocation, parts will then remain open to order as normal with no PTEC/PAV or email required.**

Part No.	Designation	Qty.
00004399052	⇒ Right rear seat-belt buckle - includes: Multiple-tooth screw for securing right seat-belt buckle	1 ea.
PAB88637300	⇒ Fixing clip	2 ea. (only if required)

Required tools

- Tools:
- **9943 - Disassembly tool**
 - Torque wrench, 20-100 Nm (15-74 ftlb.), e.g. **VAS 5820 - Torque wrench, 20-100 Nm (15-74 ftlb.)** (or locally available equivalent option)

Preparatory work

- Work Procedure: 1 Move right rear seat all the way forward.
- 2 Unclip trims ⇒ *ISOFIX trim -1-* on all ISOFIX brackets.

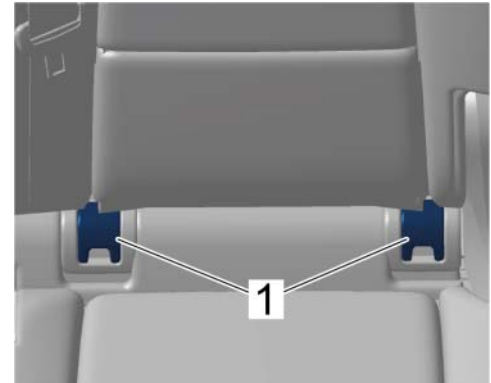
*ISOFIX trim*

- 3 Release locking lugs ⇒ *ISOFIX cover -1-* and remove cover on ISOFIX bracket ⇒ *ISOFIX cover -2-*.
- 4 Loosen padding for rear seat surface (1/3-split folding rear seat).

**Information**

A modified fixing clip for securing the padding on the rear seat surface has been used during series production since 17.09.2018.

Overview of fixing clips

- Fixing clip **version 1** (up to 17.09.2018). The fixing clip must be **replaced** following removal.

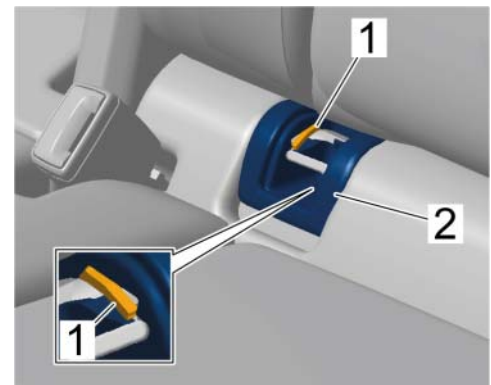
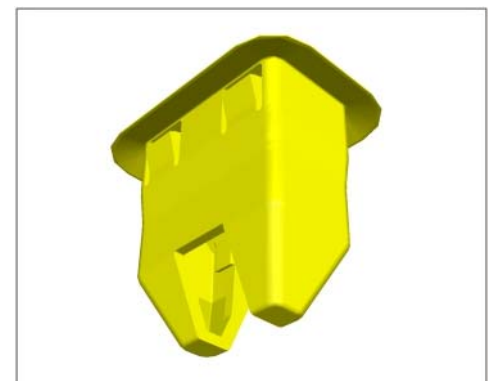
*ISOFIX cover**Fixing clip version 1*

- Fixing clip **version 2** (from 17.09.2018). The fixing clip can be re-used.



Fixing clip version 2

Depending on which fixing clip is used in the vehicle, continue with either Step 4.1 or Step 4.2.

4.1 Detach padding for rear seat surface (1/3-split folding rear seat) - **vehicles with fixing clip version 1**.

- 4.1.1 **9943 - Disassembly tool** ⇒
Padding for rear seat surface (1/3-split folding rear seat) -3-
 must be pushed onto the fixing clip
 ⇒ *Padding for rear seat surface (1/3-split folding rear seat) -1-*
 on the underside of the padding
 ⇒ *Padding for rear seat surface (1/3-split folding rear seat) -arrow-*.

Pull the padding up slightly and keep pulling it in order to release the fixing clip.

- 4.1.2 Unclip fixing clip ⇒ *Padding for rear seat surface (1/3-split folding rear seat) -1-* from the seat frame.

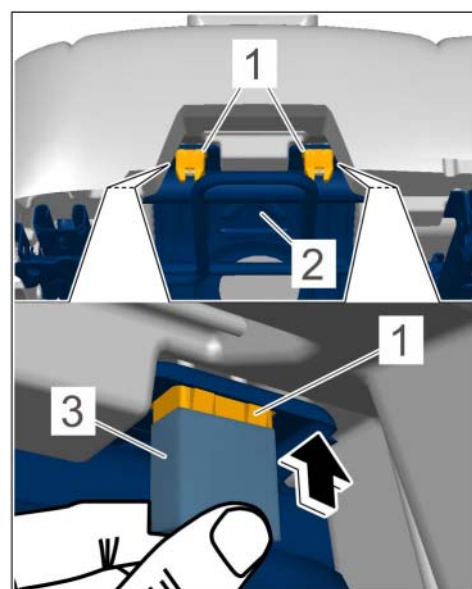

Padding for rear seat surface (1/3-split folding rear seat)

- 4.1.3 Lift up padding for rear seat surface (1/3-split folding rear seat) ⇒ *Padding for rear seat surface (1/3-split folding rear seat) -1-* with fixing clip ⇒ *Padding for rear seat surface (1/3-split folding rear seat) -2-* and fold it over to the rear.

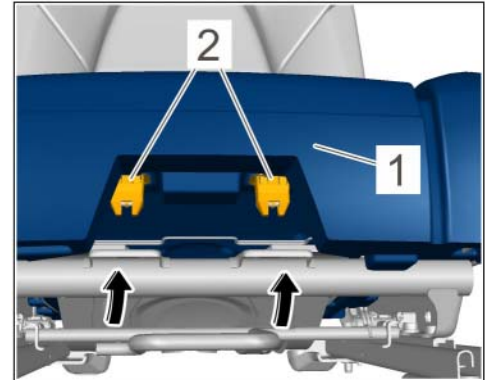

*Padding for rear seat surface
(1/3-split folding rear seat)*

- 4.1.4 Remove fixing clips (2 x) on the underside of the padding. To do this, release the locking lugs on the wire clip using a screwdriver ⇒ *Replacing fixing clip -arrows A-* and remove the fixing clip ⇒ *Replacing fixing clip -arrow B-*.



Replacing fixing clip

- 4.2 Detach padding for rear seat surface (1/3-split folding rear seat) - **vehicles with fixing clip version 2**.
- 4.2.1 Release fixing clip ⇒ *Padding for rear seat surface (1/3-split folding rear seat) -1-* using a screwdriver ⇒ *Padding for rear seat surface (1/3-split folding rear seat) -arrow A-*.
- 4.2.2 Pull padding for rear seat surface (1/3-split folding rear seat) ⇒ *Padding for rear seat surface (1/3-split folding rear seat) -2-* up and out ⇒ *Padding for rear seat surface (1/3-split folding rear seat) -arrow B-*.

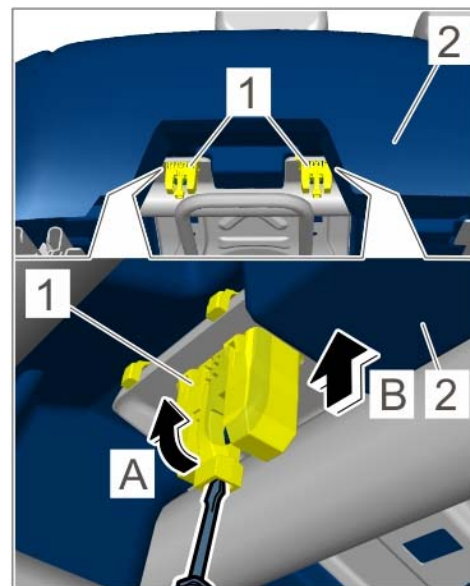

Padding for rear seat surface (1/3-split folding rear seat)

Replacing right rear seat-belt buckle



Incorrect handling of safety bolts

- **Danger of injury**
 - **Loss of torque**
- ⇒ **Always use new fastening screws and nuts following removal.**
- ⇒ **Observe specified tightening torques.**
- ⇒ **Carry out a visual inspection of all re-used parts.**



Information

The procedure for replacing the **rear right** seat-belt buckle is shown on the rear left seat-belt buckle as an example in the description below.

Work Procedure: 1 **Remove right rear seat-belt buckle.**

**Information**

Always replace screws on the seat-belt buckle after customer service and reworking.

- 1.1 Unscrew screw \Rightarrow *Screw for seat-belt buckle -1-* on the right rear seat-belt buckle.
- 1.2 Remove right rear seat-belt buckle.



Screw for seat-belt buckle

2 Install right rear seat-belt buckle.

- 2.1 Installation is performed in reverse order. Pay particular attention to the following:
Check that the spring \Rightarrow *Rear belt lock -1-* and positioning pin \Rightarrow *Rear belt lock -2-* are positioned correctly as shown.
- 2.2 Tighten screw on right rear seat-belt buckle.
Tightening torque 40 Nm (30 ftlb.)

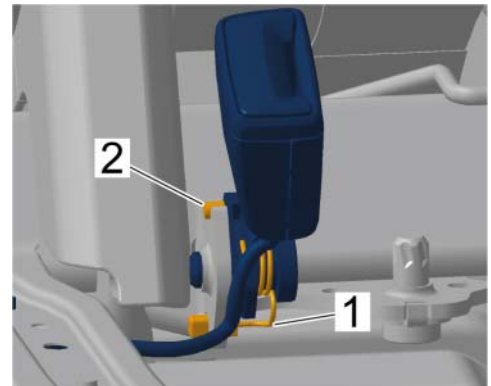

Rear belt lock

Part No.	Designation	Qty.
00004399052	Right rear seat-belt buckle	1 ea.

Concluding work

Work Procedure: 1 Installation is performed in reverse order. Pay particular attention to the following:

- 1.1 **Only for vehicles with fixing clip version 1:** Press new fixing clips ⇒ *Installing padding -3-* into the seat frame until they lock with an audible click.

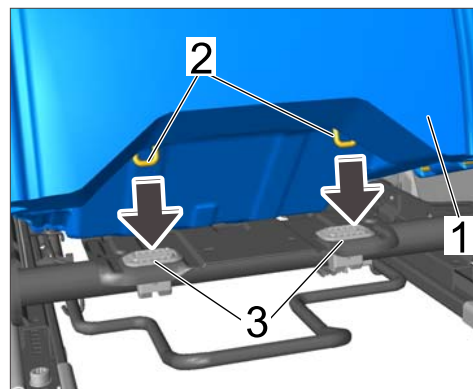

Installing padding

Part No.	Designation	Qty.
PAB88637300	Fixing clip*	2 ea. (only if required)

* Fixing clips version 1 will be replaced by fixing clips version 2 when existing stocks are used up. Both versions can be used.

- 1.2 Position padding and check that the padding is fitted correctly in the seat-belt buckle area.
- 1.3 Clip in retaining eyelets ⇒ *Installing padding -2-* on the padding at the front ⇒ *Installing padding -1-* by pressing them firmly into the fastening grommets until the retaining eyelets engage securely in the fastening grommets.
- 2 Enter the campaign in the Warranty and Maintenance booklet.

Warranty processing

Scope 1:

Working time:

Replacing rear right seat-belt buckle

Labor time: **44 TU**Includes: Removing and installing padding for rear seat surface
(1/3-split folding rear seat)**Parts required:**

00004399052	Right rear seat-belt buckle - includes: Multiple-tooth screw for securing right seat-belt buckle	1 ea.
PAB88637300	Fixing clip	2 ea. (only if required)

: ⇒ **Damage Code AJ09 099 000 2**

Important Notice: Technical Bulletins issued by Porsche Cars North America, Inc. are intended only for use by professional automotive technicians who have attended Porsche service training courses. They are written to inform those technicians of conditions that may occur on some Porsche vehicles, or to provide information that could assist in the proper servicing of a vehicle. Porsche special tools may be necessary in order to perform certain operations identified in these bulletins. Use of tools and procedures other than those Porsche recommends in these bulletins may be detrimental to the safe operation of your vehicle, and may endanger the people working on it. Properly trained Porsche technicians have the equipment, tools, safety instructions, and know-how to do the job properly and safely. Part numbers listed in these bulletins are for reference only. The work procedures updated electronically in the Porsche PIWIS diagnostic and testing device take precedence and, in the event of a discrepancy, the work procedures in the PIWIS Tester are the ones that must be followed.

© 2018 Porsche Cars North America, Inc.