



**Table 3. Motorcycles Affected**

Year	Platform	Models
2017	Softail	FLSS, FLSTFBFS, FXSE
	Touring, CVO Touring, Touring Police, Trike	FLHP, FLHR, FLHRC, FLHRXS, FLHTCU, FLHTK, FLHTKL, FLHTK SHRINE, FLHTP, FLHX, FLHXS, FLTRU, FLTRX, FLTRXS, FLRT, FLHTCUTG, FLHTKSE, FLHXSE
2018	Touring, CVO Touring, Touring Police, Trike	FLHP, FLHR, FLHRC, FLHRXS, FLHTCU, FLHTK, FLHTK ANV, FLHTK SHRINE, FLHTKL, FLHTP, FLHX, FLHX ANV, FLHXS, FLHXS ANX, FLTRU, FLTRX, FLTRXS, FLRT, FLHTCUTG, FLHTCUTG ANV, FLHTKSE, FLHTKSE ANV, FLHXSE, FLTRXSE

### Markets Affected

All markets are affected.

### Kit Part Number

Refer to Table 4.

**Table 4. Kit Part Number**

Early Kit Part No.	Item Description	New Kit Part No.
91500093	Secondary clutch actuator piston assembly kit	91500093A

### Kit Ordering Information

**Early Kits:** Kits will start shipping the week of November 5, 2018 and ending February 22, 2019.

**New Kits:** Kits will start shipping the week of February 25, 2019.

#### U.S. and Canada Markets

Wave shipments of kits will be done automatically by Harley-Davidson.

An updated service bulletin will be released once dealer ordering may begin.

#### Asia Pacific Market

Contact the Service and Customization Consultant.

#### Europe Market

Contact the Service and Customization Consultant.

#### India Market

Contact the Service and Customization Consultant.

#### Mexico Market

Contact the local service area representative at Harley-Davidson Mexico.

## Procedure Video

A video of the procedure has been posted on SIP (Service information portal). This video covers the procedures that are not covered in the service manuals.

**SIP Video Link:** Video: M1482 - Recall 0173

### Required Dealer Action

1. Verify that vehicle is part of recall 0173.

### Prepare

*NOTE*

- To avoid cross contamination, this procedure must be performed in a clean work area. Continuously clean the work area of any brake fluid and/or transmission fluid. Clean all tools and anything that comes in contact with parts or gloved hands.
- **Touring:** When referred to "See the service manual", use the 2019 Touring service manual.
- **Softail:** When referred to "See the service manual", use the 2017 Softail service manual.

1. **Touring:** Remove main fuse. See the service manual: **Electrical > Power Disconnect > Main Fuse.**
2. **Softail:** Remove main fuse.
  - a. **Models with security:** Disable security system.
  - b. Verify that fob is present.
  - c. Turn OFF/RUN switch to RUN.
  - d. Turn ignition switch ON.
  - e. Remove seat. See the service manual: **Chassis > Seat (select model).**
  - f. Remove main fuse. See the service manual: **Electrical > Fuse > Removal.**
  - g. Turn ignition switch OFF.

### Removal

1. Drain clutch control system.
  - a. **Touring:** See the service manual: **Chassis > Bleed Clutch Control System > Drain and Fill > Drain.**
  - b. **Softail:** See the service manual: **Chassis > Bleeding Clutch Fluid Line: Hydraulic Clutch > Drain and Fill > Drain.**

*NOTE*

- A small amount of transmission lubricant may drain when secondary clutch actuator is removed.
- **Do not disconnect clutch fluid line (4).**

2. Refer to Figure 1. Remove secondary clutch actuator (1) from inner side cover mounting bore (2).
  - a. Remove screws (5) and secondary clutch actuator.
3. Refer to Figure 2. Place **clean** lint free shop towel over transmission inner side cover at secondary actuator bore.

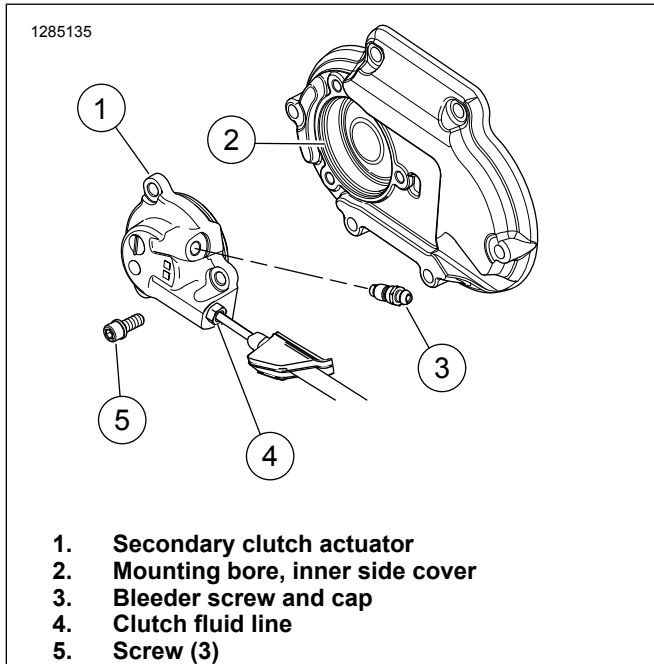

Figure 1. Secondary Clutch Actuator

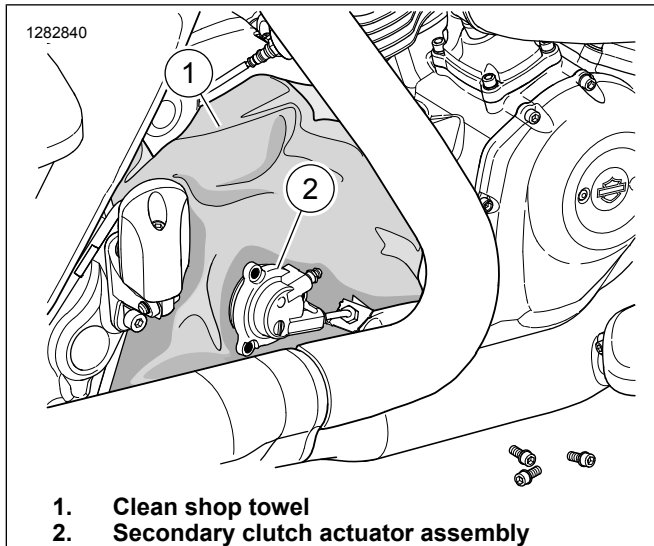

Figure 2. Towel In-Place on Transmission

### Disassembly

#### NOTE

To avoid scratching the transmission seal seat (2), **do not** use any tools to remove the transmission seal boot (4) from actuator housing (1).

1. Refer to Figure 3. Remove the actuator piston assembly (3).
  - a. Refer to Figure 4. Pinch the actuator transmission seal boot (4).
  - b. Refer to Figure 3. Remove the transmission seal boot from the transmission seal seat (2).
  - c. Remove piston assembly from actuator housing (1).
2. Discard old actuator piston assembly.

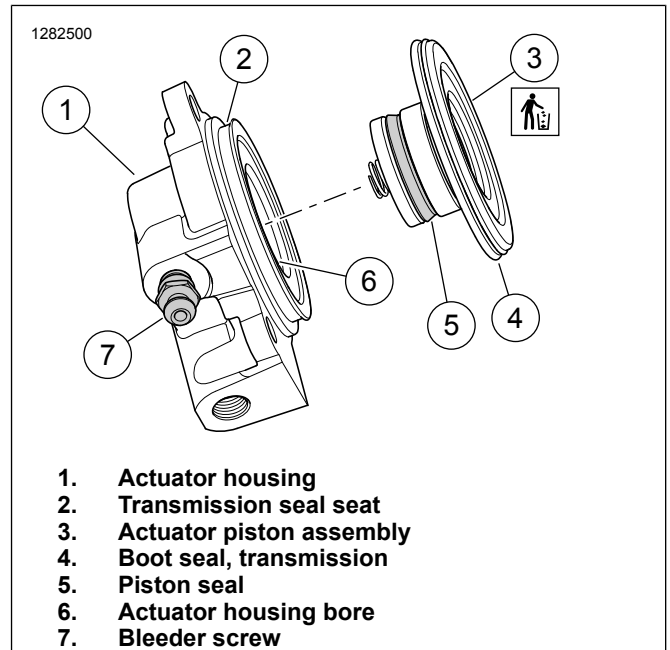

Figure 3. Secondary Actuator Assembly

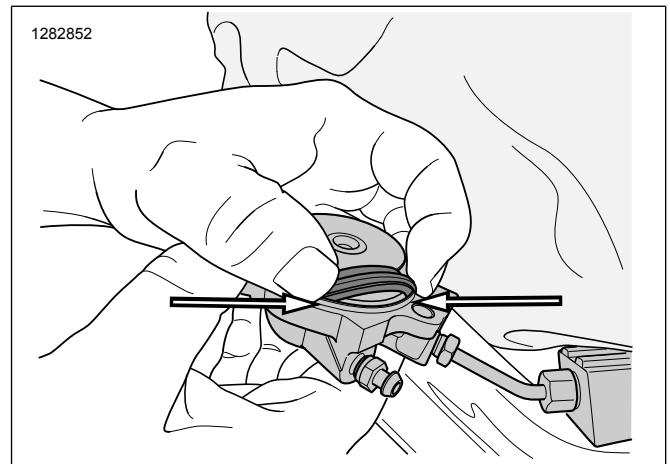

Figure 4. Pinching Actuator Transmission Seal Boot

### Clean and Inspect

1. Put supplied hand gloves on (may contain latex).
  - a. Verify that hands are free of transmission fluid, dirt or debris before putting on gloves.

**NOTE**

Only use the provided wipe to clean the actuator bore and transmission seal seat area (2, 6).

2. Refer to Figure 3. Clean actuator.
  - a. Use the provided wipe, thoroughly clean the actuator bore and transmission seal seat area (2, 6).
3. Inspect actuator bore for damage.
  - a. If damage is found, call Technical Service.

**Assembly**

1. Locate **new** actuator piston assembly.

**NOTE**

**Do not touch pre-lubed piston seal (5) when removing from packaging.**

2. Refer to Figure 3. Remove **new** actuator piston assembly (3) from packaging.
3. Inspect **new** actuator piston assembly for dirt or damage.
  - a. If dirty or damaged, do not use.
4. Install **new** actuator piston assembly.
  - a. Align **new** actuator piston assembly squarely to the actuator housing bore (6).
  - b. Refer to Figure 5. Push down on center of piston until fully seated in bore.
  - c. Refer to Figure 3. Install the transmission boot seal (4) around the transmission seal seat (2).

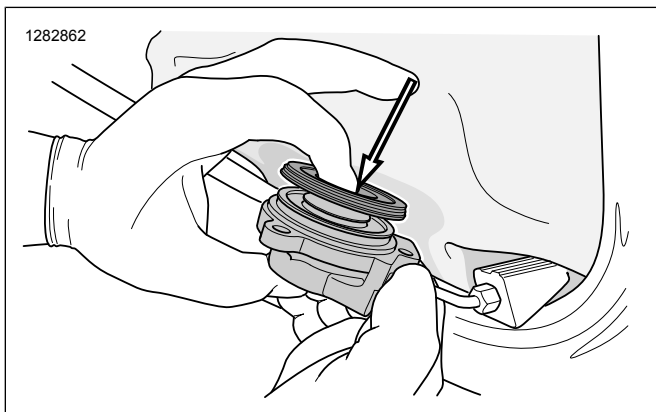

**Figure 5. Installing Actuator Piston Assembly**

**Install**

1. Remove shop towel over transmission inner side cover at secondary actuator bore.

**NOTE**

**Do not actuate clutch while secondary actuator assembly is removed from inner side cover after installing the **new** actuator piston assembly.**

2. Refer to Figure 1. Install secondary clutch actuator (1).
  - a. Lubricate mounting bore (2) in the inner side cover with a film of transmission fluid.
  - b. Install secondary clutch actuator (1) and screws (5).
  - c. Refer to Figure 6. Draw screws down evenly to prevent binding and possible breakage of mounting ears. Tighten in sequence as shown.  
Torque: 8–10 ft-lbs (11.2–13.6 N·m)

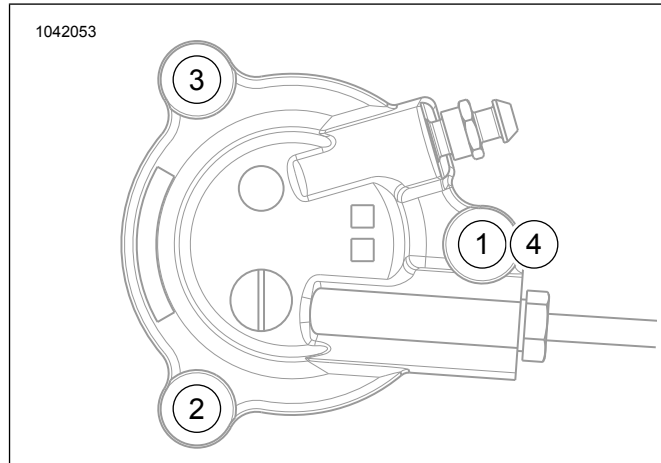
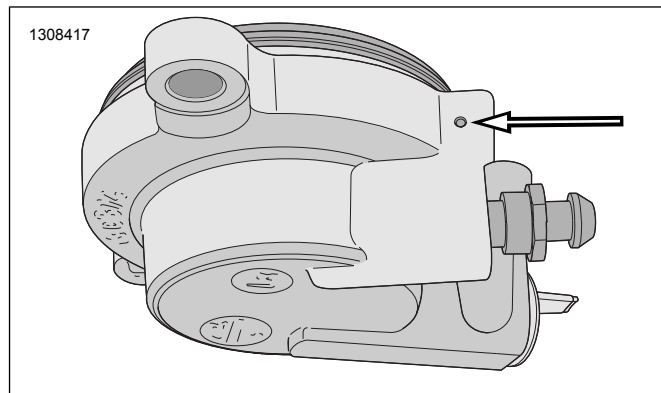

**Figure 6. Secondary Clutch Actuator Torque Sequence**

**NOTE**

Use a mechanical spring loaded center punch, if not available use a standard center punch.

3. **Kit 91500093A:** Refer to Figure 7. Install identifying mark in secondary clutch actuator.
  - a. Using a center punch, lightly punch a identifying mark as shown.



**Figure 7. Identifying Mark Location**

4. Fill and bleed clutch control system.
  - a. **Touring:** See the service manual: **Chassis > Bleed Clutch Control System > Drain and Fill > Fill.**
  - b. **Softail:** See the service manual: **Chassis > Bleeding Clutch Fluid Line: Hydraulic Clutch > Drain and Fill > Fill.**
5. After bleeding, remove clutch cover and measure release plate movement.

**▲ WARNING**

**Insufficient clutch-release plate movement can lead to difficulty or inability to shift, causing loss of control, which could result in death or serious injury. (00345a)**

6. Attach a dial indicator to measure pushrod axial movement.
7. Actuate clutch lever to measure axial movement of pushrod and clutch-release plate assembly.
  - a. Minimum release plate movement is 0.086 in (2.18 mm)
  - b. If release plate movement is equal to or greater than minimum value, go to Section Clutch Lever Hold-In Test.
  - c. If release plate movement is less than minimum value, repeat bleed procedure.

**Clutch Lever Hold-In Test**

1. Pull in clutch lever to handlebar grip and hold for 1 min.
2. With clutch lever pulled in, verify the dial indicator reading **does not** change.
3. If reading holds, go to Section Complete.
4. If reading **does not** hold:
  - a. Repeat bleed procedure, and test again.
  - b. Refer to Figure 3. If hold-in test continues to fail, remove actuator piston assembly (3) and inspect piston seal (5) and actuator housing bore (6). Refer to Section Clean and Inspect.
  - c. Call Technical Service if damage is found.

**Complete**

1. Refer to Figure 8. Install outer transmission side cover.
  - a. Install outer cover (1).
  - b. Install screws (4). Tighten.  
Torque: 99–120 **in-lbs** (11.2–13.6 N·m)

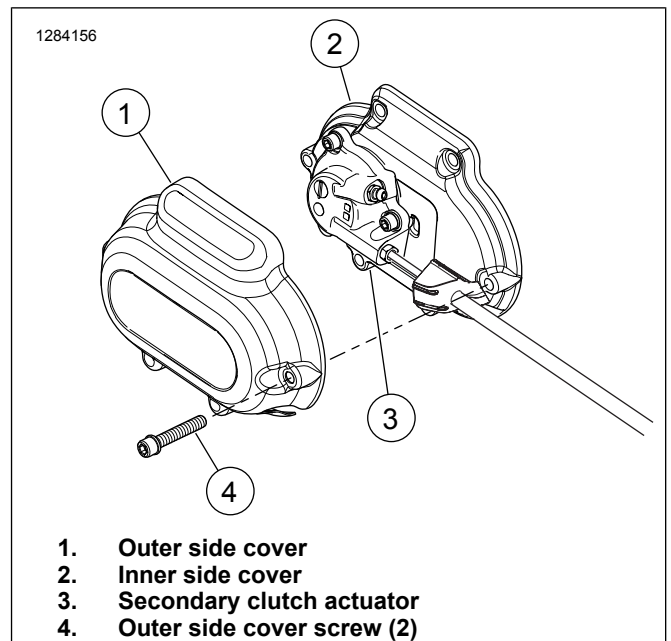

**Figure 8. Transmission Outer Side Covers**

2. Secure exhaust system.
  - a. **Touring:** See the service manual: **Fuel and Exhaust > Exhaust System > Install.**
  - b. **Softail:** See the service manual: **Fuel System > Exhaust System > System: (select model) > Installation.**
3. Install clutch cover.
  - a. Thoroughly clean oil from clutch cover and mating surface on primary cover.
  - b. Install clutch cover, new gasket and screws.
  - c. Refer to Figure 9. Tighten screws in sequence shown.  
Torque: 84–108 **in-lbs** (9.5–12.2 N·m)

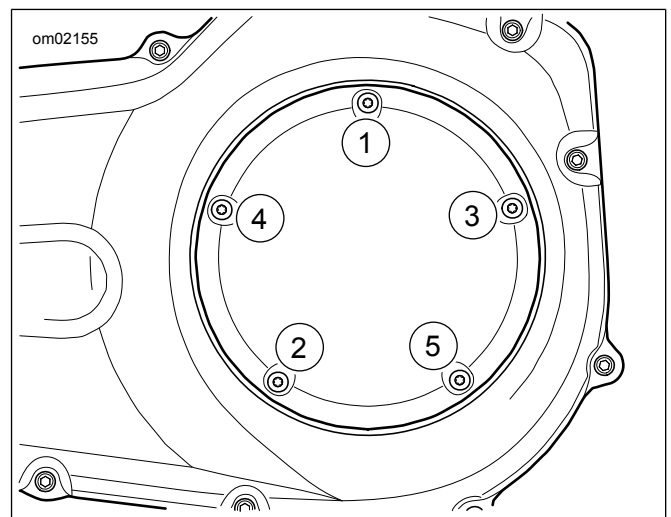

**Figure 9. Clutch Cover Tightening Sequence**

4. Install main fuse.
  - a. **Touring:** See the service manual: **Electrical > Power Disconnect > Main Fuse.**
  - b. **Softail:** See the service manual: **Electrical > Fuse > Installation.**
5. Perform a road test to verify clutch operation.

## Dealer Inventory Instructions

### Old Secondary Actuator Piston Assembly Stock

If dealers have old stock. Refer to Table 5.

File a DFS (Defective stock) claim and replace with update part. Refer to Table 6.

**Table 5. Part Numbers**

Old Part No.	Item Description	Current Part No. To Use
37200131	Secondary clutch actuator piston assembly	37200131C
37200131A		
37200131B		

**Table 6. Kits in Dealer Stock**

ITEM	DATA
Claim Type	DFS/PAM Stock
Problem Part Number	37200131, 37200131A, 37200131B
Customer Concern Code	9901
Condition Code	1518

### Early Recall Kits

If dealers have early recall kits. Refer to Table 4.

File a claim and replace with update kit.

Submit a warranty claim per Table 7 or Table 8 for all existing recall kits in dealer stock.

*NOTE*

*These kits can be used until March 15, 2019*

### U.S Dealers only:

**Table 7. Kits in Dealer Stock**

ITEM	DATA
Claim Type	SNV
Problem Part Number	91500093
Quantity	Could vary
Customer Concern Code	0173
Condition Code	9982

### SAP/GDP System Users:

**Table 8. Kits in Dealer Stock**

ITEM	DATA
Claim Type	PAM - stock
Problem Part Number	91500093
Quantity	Could vary
Customer Concern Code	0173
Condition Code	9982

## Credit Procedure

Upon submission of the properly completed claim, dealers will be credited for 1.1 h of labor time for performing the procedure, plus appropriate administrative time. Credit will also be issued for the brake fluid and the recall kit (U.S. only). Submit campaign events on the dealers own warranty claim. Do not mix them with other warranty events.

*NOTE*

*Enter bulletin number into comment section of claim.*

### Credit Procedure: Talon/h-dnet.com warranty claim system users

Submit a claim for each motorcycle serviced in this bulletin for which VIN (Vehicle identification number) involvement was verified on H-Dnet.com. Refer to Table 9.

**Table 9.**

ITEM	DATA
Claim Type	SRC
Problem Part Number	37200131A
Quantity	Leave Blank
Primary Labor Code <sup>(1)</sup>	4062
Time	1.1 h
Customer Concern Code <sup>(1)</sup>	0173
Condition Code	9981
Replacement Part No.	91500093 or 91500093A <sup>(2)</sup> and 41800770
Quantity	1

*(1) Download may be required.*

*(2) See Section Overview: Step 2 for correct Part No.*

### Credit Procedure: SAP system users

Submit a claim for each motorcycle serviced in this bulletin for which VIN involvement was verified on H-Dnet.com. Refer to Table 10.

**Table 10.**

ITEM	DATA
Claim Type	Recall Claim
Fix ID-Found in Recall Number	C
Problem Part Number	37200131A
Customer Concern Code	0173
Condition Code	9981

### Credit Procedure: All Other System Users

Claim Date

Campaign Number (0173) - 1.1 h

FIX ID - (C)

Full Seventeen Character VIN

## Return Parts

Hold all claimed parts for 60 d from date of credit issued for possible field inspection and/or request to return to factory. After 60 d, destroy and discard the parts.

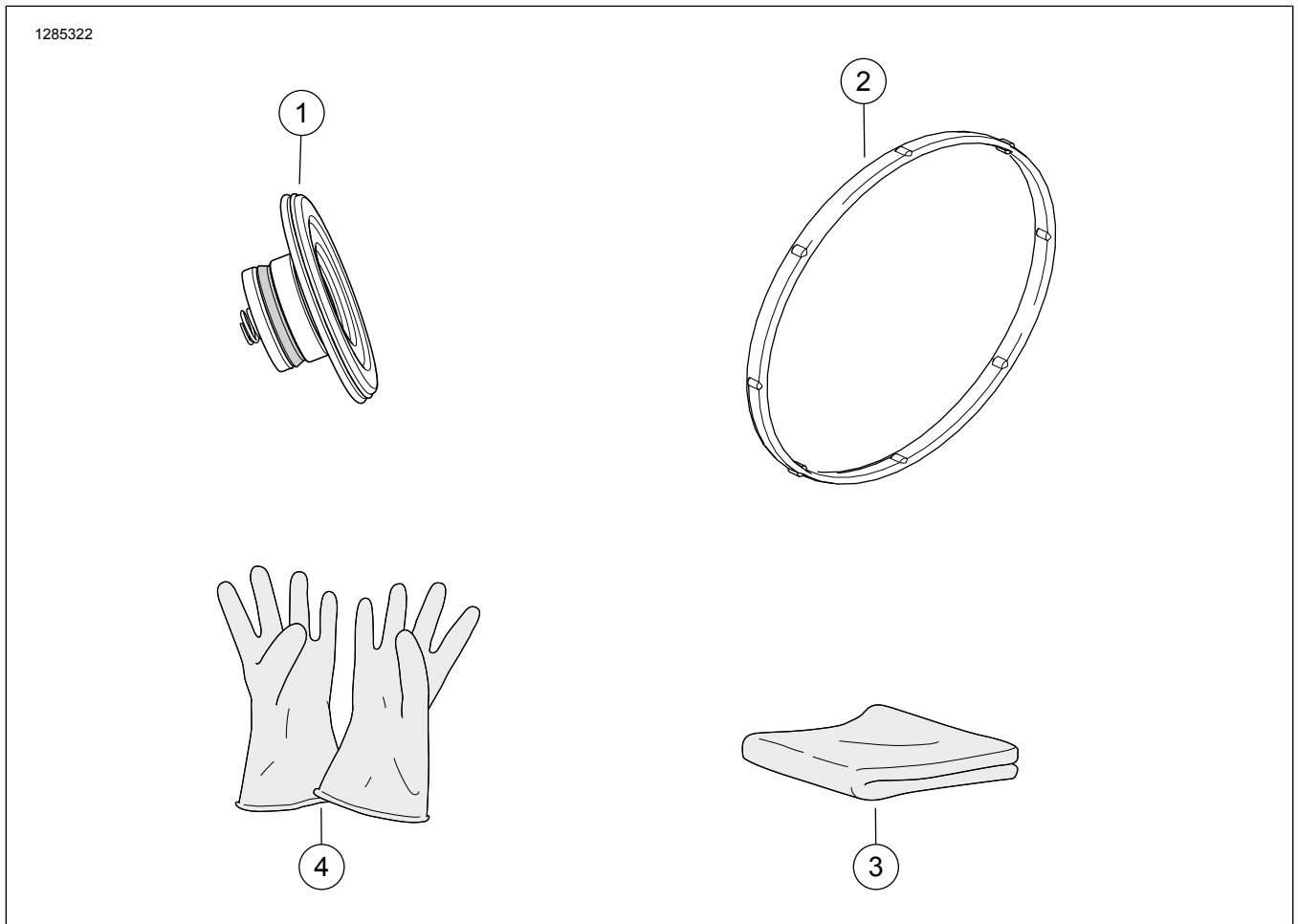

Figure 10. Service Kit - 0173

Table 11. Service Kit - 0173

Item	Description	QTY	Part Number
1	Clutch Actuator Piston Assembly	1	Not Sold Separately
2	Clutch Cover Gasket	1	Not Sold Separately
3	Cleaner Wipe	1	Not Sold Separately
4	Hand Gloves, Vinyl (may contain latex)	2	Not Sold Separately