

MODEL:	TYPE:	SECTION/GROUP:	DATE:
<b>J Series</b>	<b>Field Change Program</b>	<b>03- Body</b>	

Ref. MCI NHTSA Recall No.: 18V-692

Ref. MCI Transport Canada Recall No.: 2018-545

**Customer Complaint:**

Motor Coach Industries ("MCI") has become aware that the 60-seater MY2018-J4500 coaches do not meet the minimum egress area specified in FMVSS 217/CMVSS 217.

**Cause:**

The egress area was not increased when the increased seating capacity was put into production resulting in noncompliance with FMVSS 217/CMVSS 217 on those units with a 60-passenger seating layout.

**Corrective Action:**

MCI urges owners of the affected coaches to have the following procedure performed as soon as possible.



***Read this entire procedure before beginning work.***

***Use Safe Shop Practices At All Times.***

***To avoid personal injury:***

- a. Turn the main battery disconnect switch to the OFF position.***
- b. Ensure that both the front and the rear wheels are chocked.***
- c. Position the ENGINE RUN and ENGINE START switches on the engine compartment remote control box to the OFF position.***
- d. Allow enough time for components to cool down prior to working in the engine compartment.***



## 1.0 Material Requirements:

Service kit **T03-2985** contains the following parts:

Item	Part number	Quantity	Description
1	03-27-1074	4	TRI/MARK ROTARY LATCH
2	03-27-2028	8	SCR, ¼-20 X 7/8" LG. PAN HD
3	03-27-2037	4	LATCH HOUSING
4	03-27-2036	4	RELEASE BAR HINGE
5	03-27-2034	16	SCR, 8-32 X 9/32" LG. TRUSS HD. TAPETITE
6	03-27-1065	4	HINGE PIN
7	03-27-1066	8	SCR, 10-32 X 3/8" LG. TRUSS HD
8	03-27-1067	4	RELEASE BAR SPRING
9	03-27-1914	8	SCR, 8-32 X 5/16" LG. PAN HD
10	03-27-1068	8	RECESS BUMPER
11	03-27-2033	8	SCR, #8 TYPE B X 5/8" LG. PAN HD
12	03-27-2022	4	BRACKET, RELEASE BAR
13	03-27-2023	4	FORMED ROD
14	03-27-2018	4	ROD CLIP
15	03-27-2027	8	NYLON WASHER
16	03-15-7274	6	NAME PLATE- EMERGENCY EXIT, EN, E/J COACH
17	03-15-7275	4	NAME PLATE- EMERGENCY EXIT, FR, E/J COACH
18	03-15-7276	4	NAME PLATE- EMERGENCY EXIT, SP, E/J COACH
19	19-2-37	8	WASHER-LOCK, SST, 1/4DIA
20	19-1-684	8	SCREW-TAPPING, SELF DRILLING, TYPE BSD, #2
21	03-27-1336	4	GASKET-FRICTION, SASH CAM
22	03-27-1338	4	SHIM-OVERCENTER, SASH, CAM

23	03-27-1380	4	CAM-NYLON, SASH
24	03-27-1381	4	CAM-STRIKER, SASH
25	19-1-603	8	SCREW, PAN HD- #8-32
26	19-3-155	8	NUT-HEX, LOCK, #8-32, STL
27	03-27-1137	4	SIDE SASH STRIKER
28	19-01-1571	8	SCREW-FLANGE WHIZLOCK
29	19-2-69	16	WASHER-FLAT, 1/4"DIA., STEEL ZINC PLATED
30	19-13-24	20	RIVET 1/8 DIA .126-187 GRIP ALUMINUM.
31	19-13-169	8	RIVET-BLIND, SELF PLUGGING, MULTI GRIP
32	19-3-469	8	NUT-RIVNUT, 1/4 - 20

## 2.0 Special Tools

Rivet remover gun, rivet install tool, and Imada push/pull scale.

## 3.0 Rework Instructions

There is one bolted window on each side of the coach that needs to be converted to egress windows. The following steps demonstrate the instructions for one window. Repeat the entire instructions for the other side to finish the procedure.

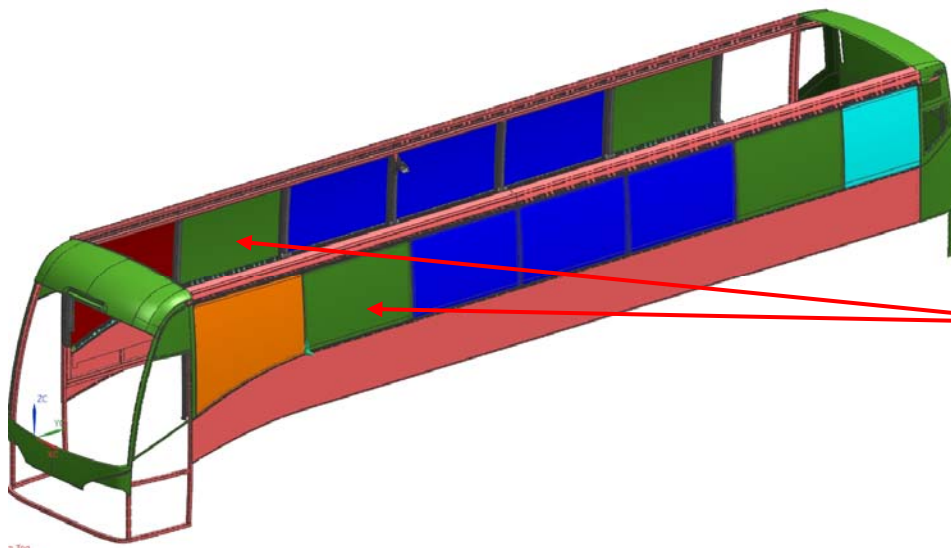

Fixed windows that need to be converted to egress windows

### 3.1 Remove the bolted window components

Remove and discard the 4 screws holding the crash bar to the window.



Remove  
and discard  
the screws

Remove the 4 screws on the window frame and discard the screws



Remove the screws

Using a rivet removal gun, remove the 8 rivets attaching the brackets to the crash bar. Discard the brackets and save the crash bar for later use.



Remove the rivets

Push the window out with the top still hanging from the hinge, and use a wooden 2" x4" between 20-25" long to hold the window open in that location.



Wooden Stopper

Remove the rivets holding the sash retainer to the frame, 03-27-1189, and discard the retainers.

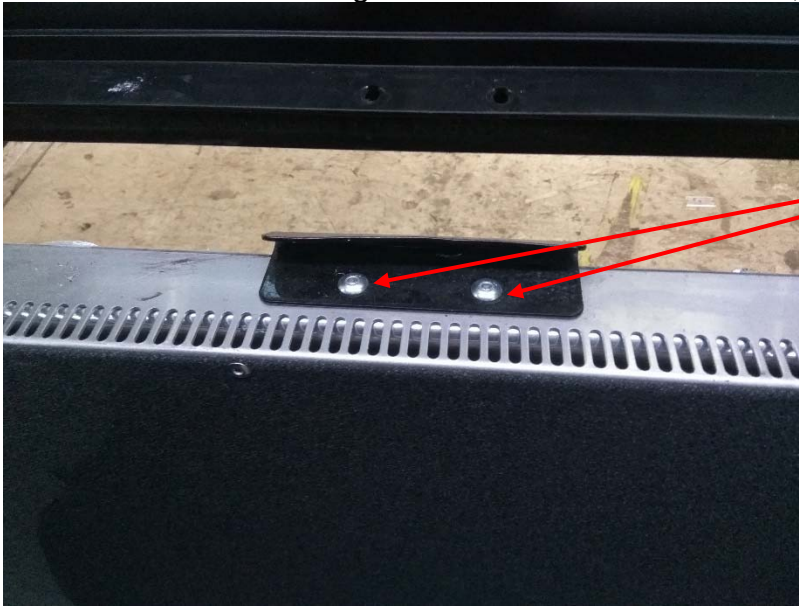

Remove the rivets and  
discard the retainer

## 3.2 Installing components for egress window

### 3.2.1 Install side-sash striker

Install side-sash striker, 03-27-1137, by aligning the slots of the striker to the existing holes previously used for the sash retainer. Be sure to align the slot center with the center of the hole. Fasten with washers, 19-2-69, and monobolt rivets, 19-13-169.



Fasten the striker  
with washers and  
monobolt rivets

### 3.2.2 Install sash cam assembly

Drill 4 new 0.391" diameter holes into the frame through the interior angle, 03-16-1759, at the location indicated below using a 25/64" drill bit.



Interior angle

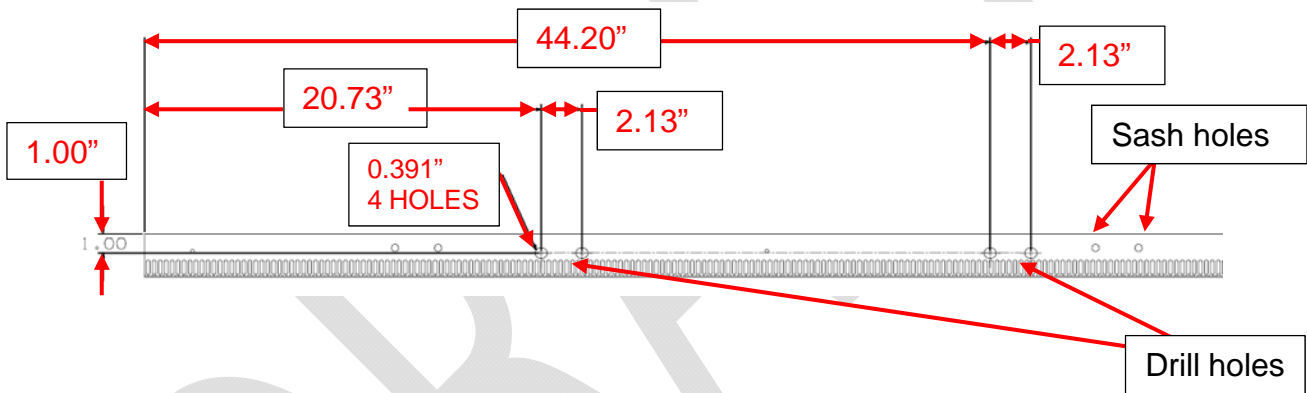

Sash holes

Drill holes

Make the newly drilled holes into 0.547"x0.625" slots into the interior angle only. Be sure not to slot the frame. Install a 19-3-469 rivnut in each slot of the interior angle.



0.547"x0.625"  
4 SLOTS

Assemble the Cam-sash by assembling the cam-nylon sash, 03-27-1380, to the cam-striker sash, 03-27-1381, by using screw, 19-1-603, and hex nut, 19-3-155, as shown below

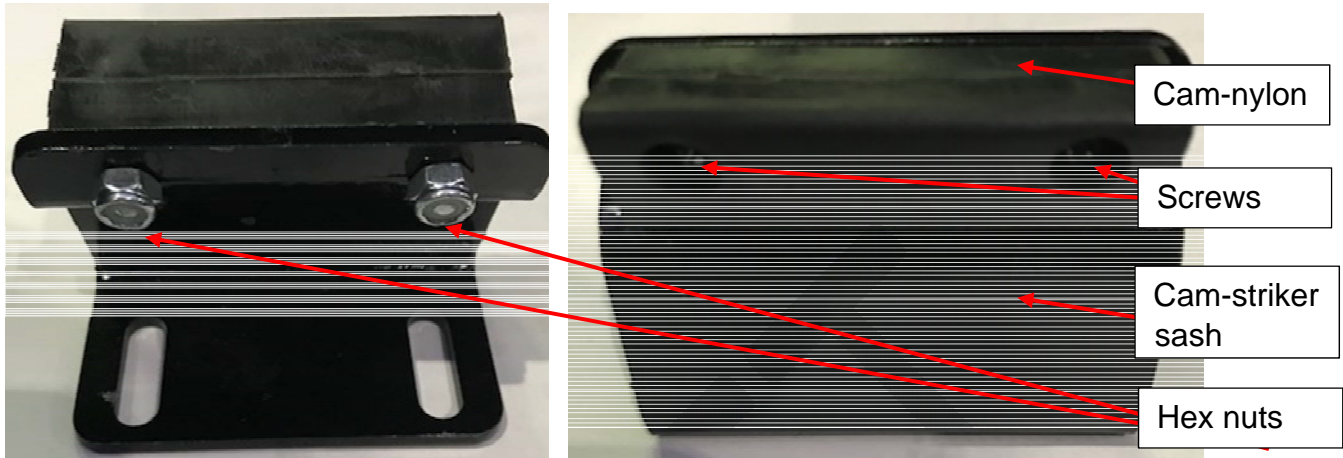

Remove the backing paper of friction gasket, 03-27-1336, and attach onto the interior angle by aligning the slots of the gasket to the just drilled holes on the interior angle.

Position sash cam assembly over the friction gasket and secure the sash tube with washer, 19-2-69, lock washer, 19-2-37, and screw, 19-01-1571, in that order.

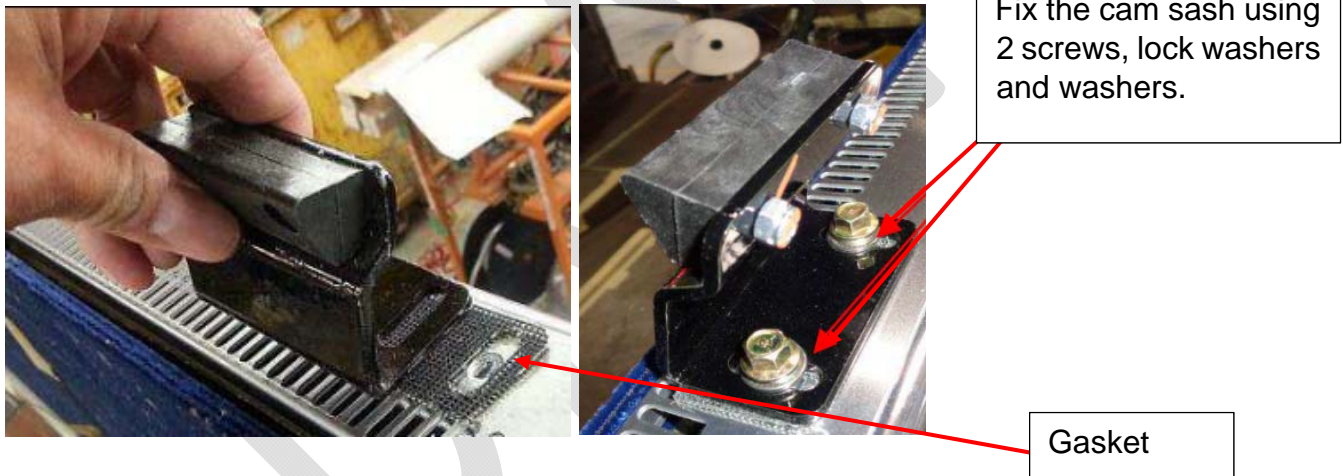



### 3.2.3 Assemble egress latch mechanism to the window

Install the rod clip, 03-27-2018, to the tri mark rotary latch as shown in the pictures below.

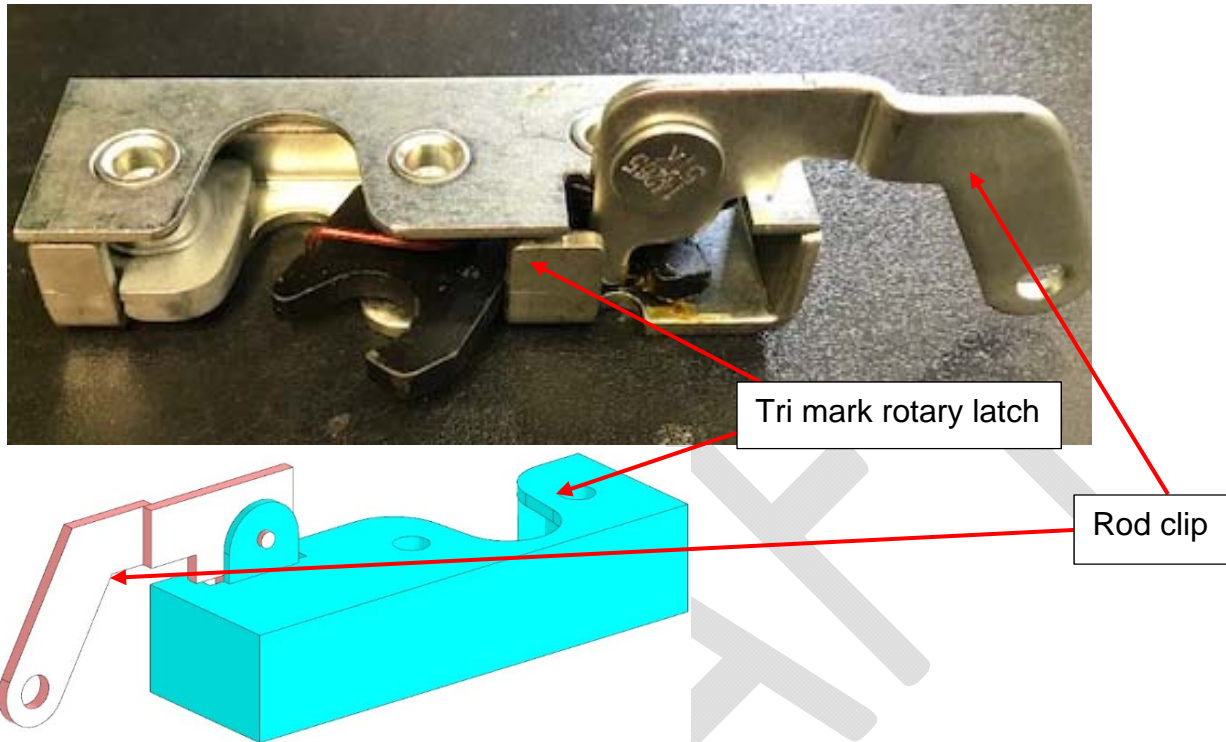

Install formed rod, 03-27-2023, using nylon washers, 03-27-2027, and the release bar bracket, 03-27-2022, as shown in the picture below to the rod clip. Place nylon washers on both sides of the formed rod.

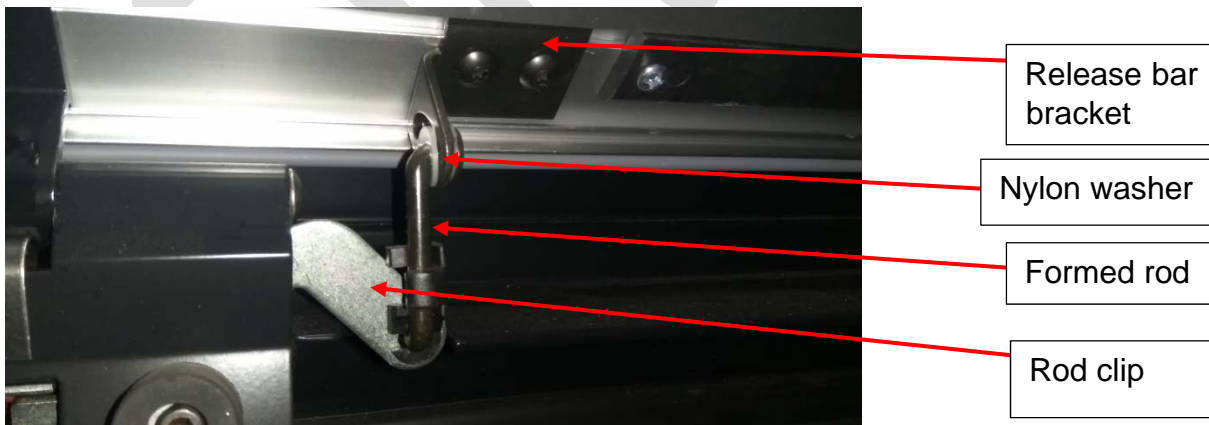

Drill two holes into the latch housing at the locations shown below using a 11/64" drill bit.

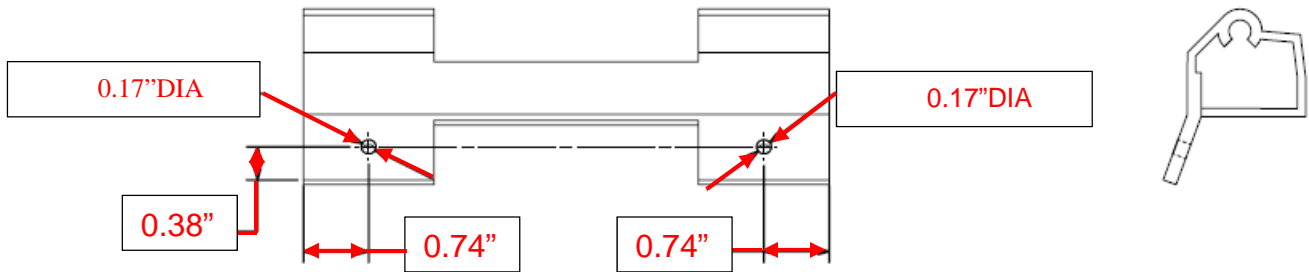

Install a recess bumper, 03-27-1068, at each hole using a screw, 03-27-2033 as shown below.

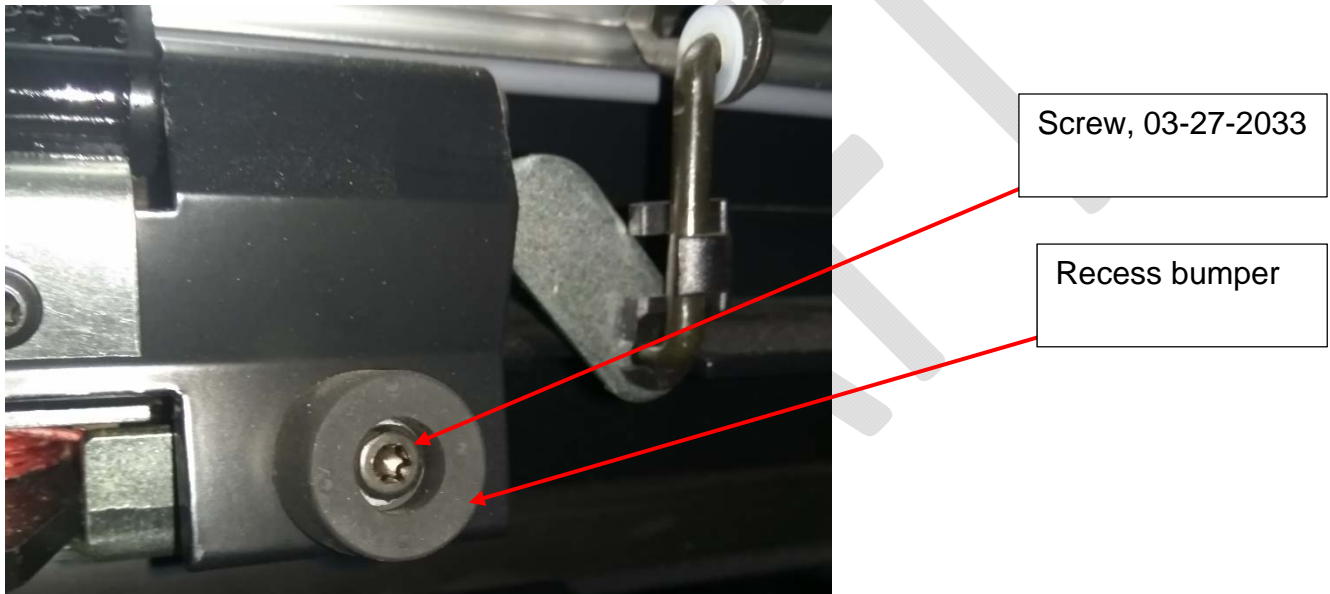

Drill 4 holes on the angle bar of the window frame using 0.3818" drill bit and using an angle grinder cut two squares as shown below.

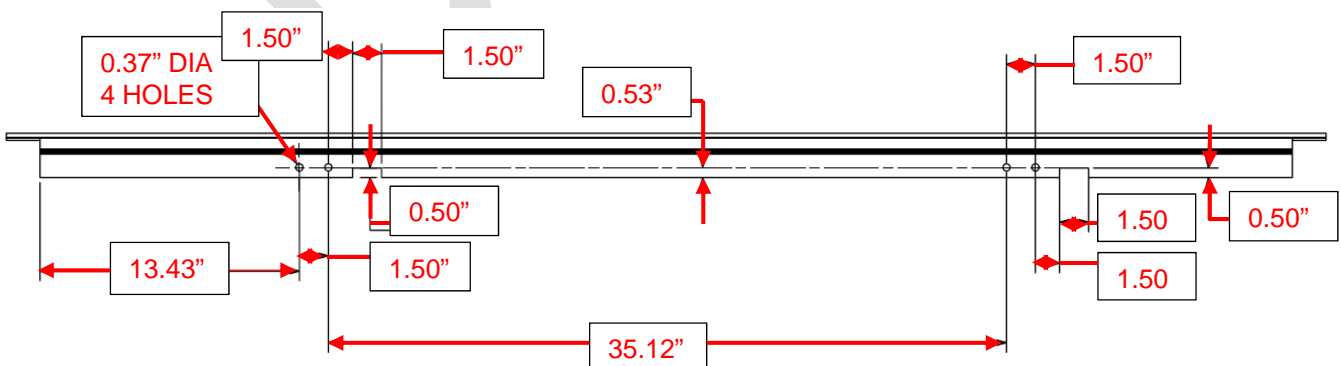

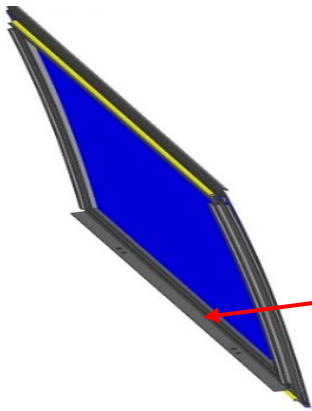

Angle bar of the window on which holes need to be drilled

Install tri/mark rotary latch, 03-27-1074, and latch housing, 03-27-2037, using 2 screws, 03-27-2028, as shown in pictures below.

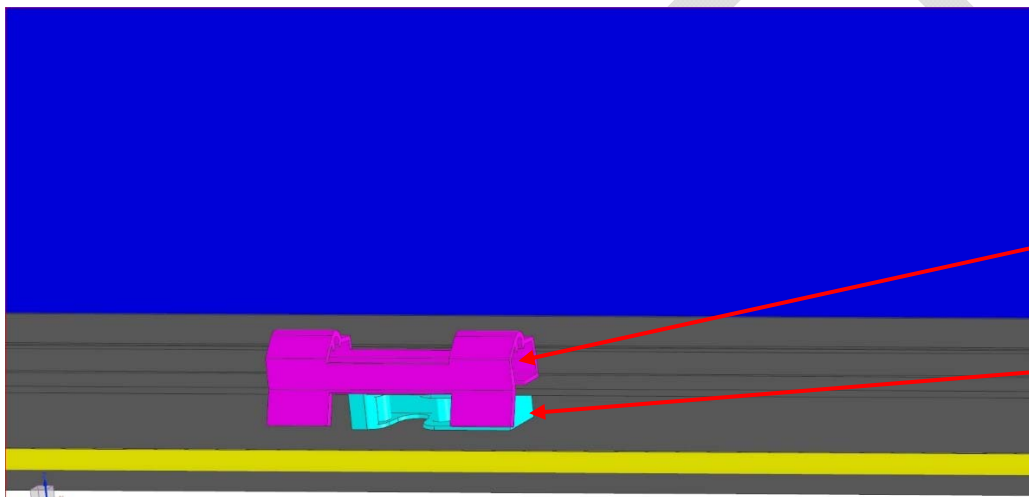

Latch housing

Tri/mark rotary latch

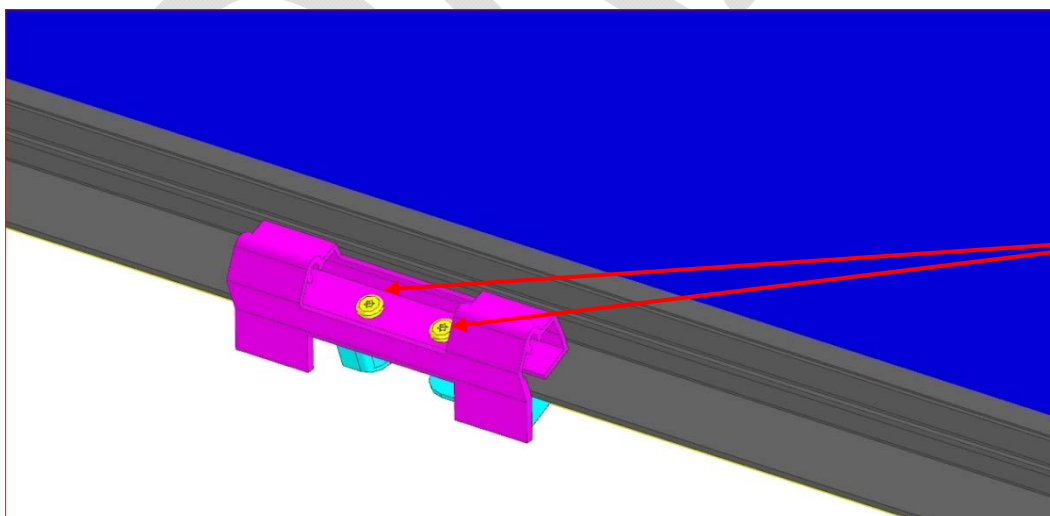

Screws

Install the release bar spring, 03-27-1067, to latch housing using screws, 03-27-1914, such that the profile of the spring sits on the profile of the latch housing.

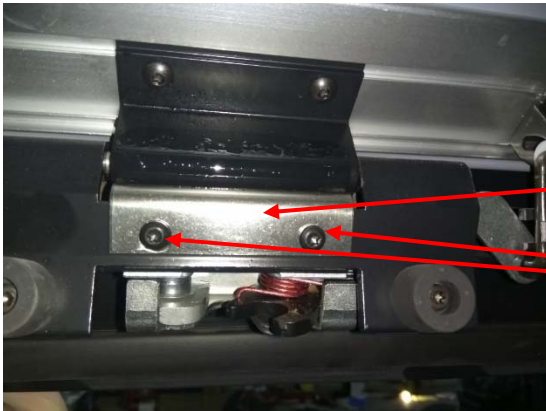

Release bar

Screws

Place the release bar hinge on the release bar spring such that the holes in the latch housing and release bar hinge are horizontal.

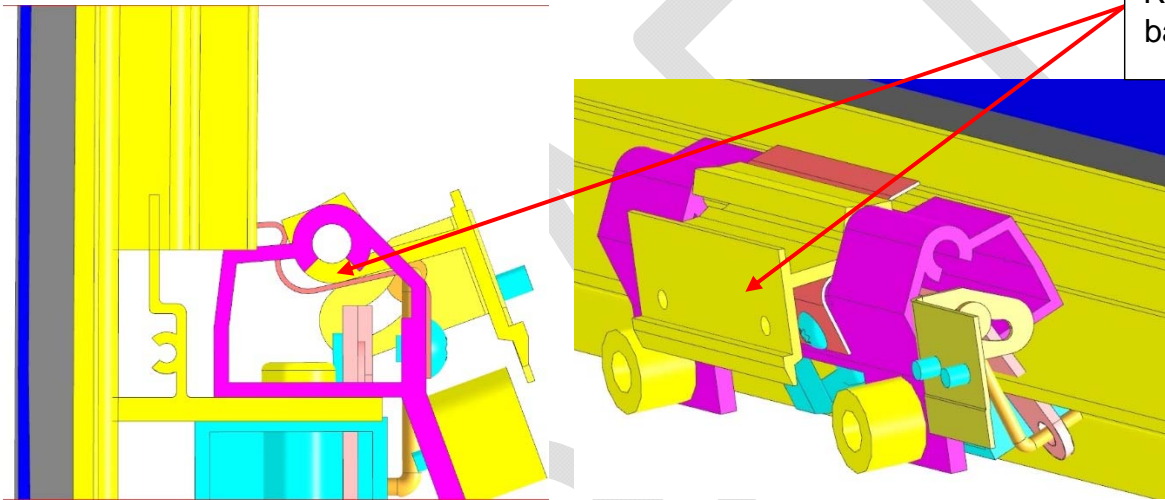

Release bar hinge

Fix the release bar hinge by inserting the hinge pin, 03-27-1065, through the holes of the latch housing and fasten screws, 03-27-1066, on either ends of the housing to lock the position.

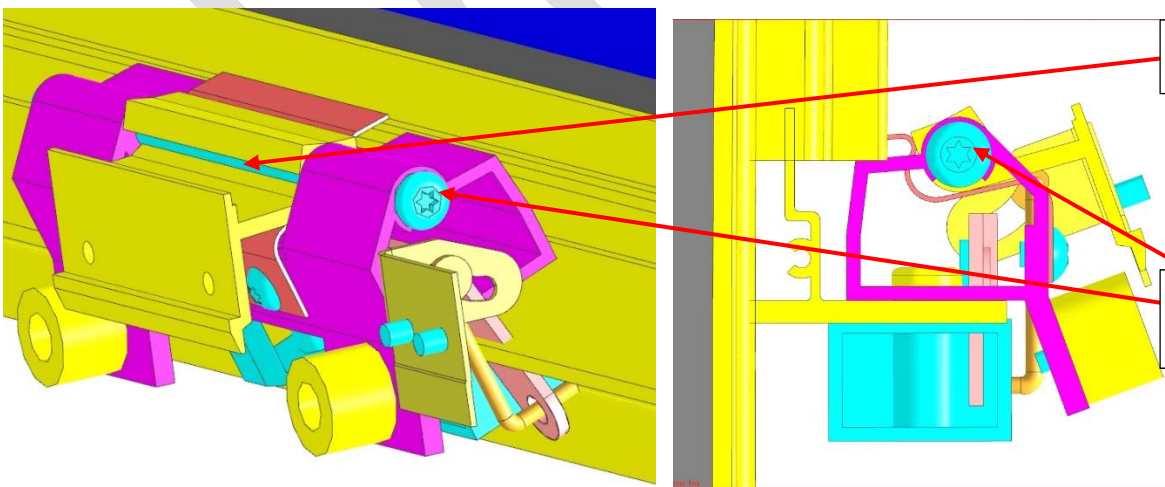

Hinge pin

Fasten screws

Position shim over center sash, 03-27-1336, on back of the crash bar at the locations indicated below. Using the shim as a template drill four 0.109 holes. Be sure to drill the holes only through the one layer of aluminum extrusion of the crash bar.

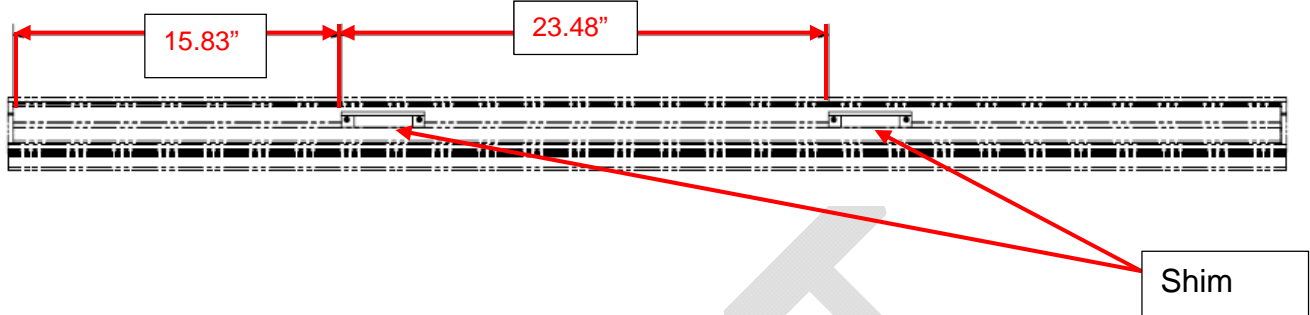

Fix the shim to the crash bar using screws, 19-1-684.

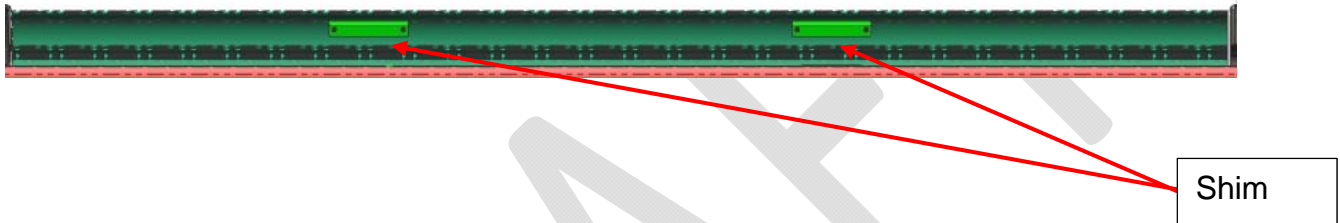

Position the crash bar on the window frame such that there is 0.37" gap between the forward facing edge of the release bar cover and the rear facing edge of the post cover.

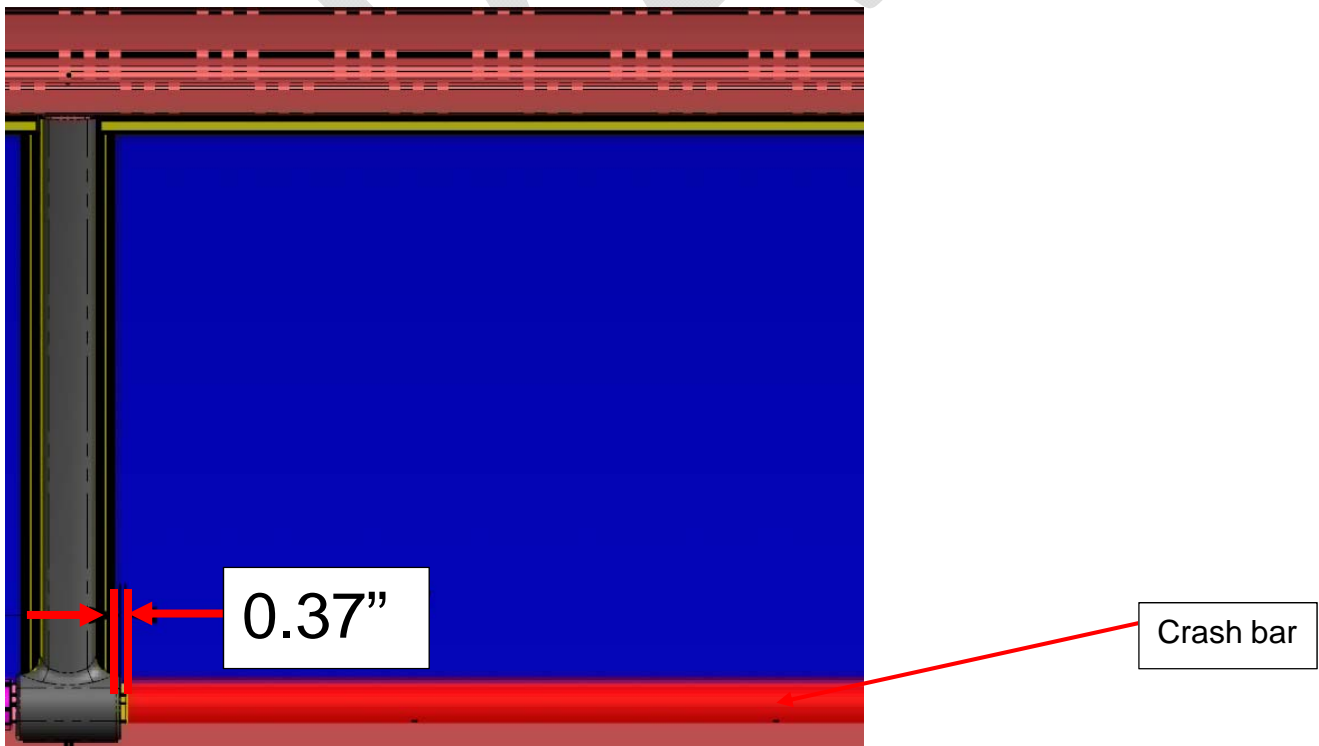

Mark the location of the release bar hinge holes and the release bar bracket holes on the crash bar and drill four 0.17" holes using 9/64 drill bit. Be sure to drill only through one layer of aluminum extrusion of the crash bar.

Fix the release bar hinge and release bar bracket using screws, 03-27-2034.

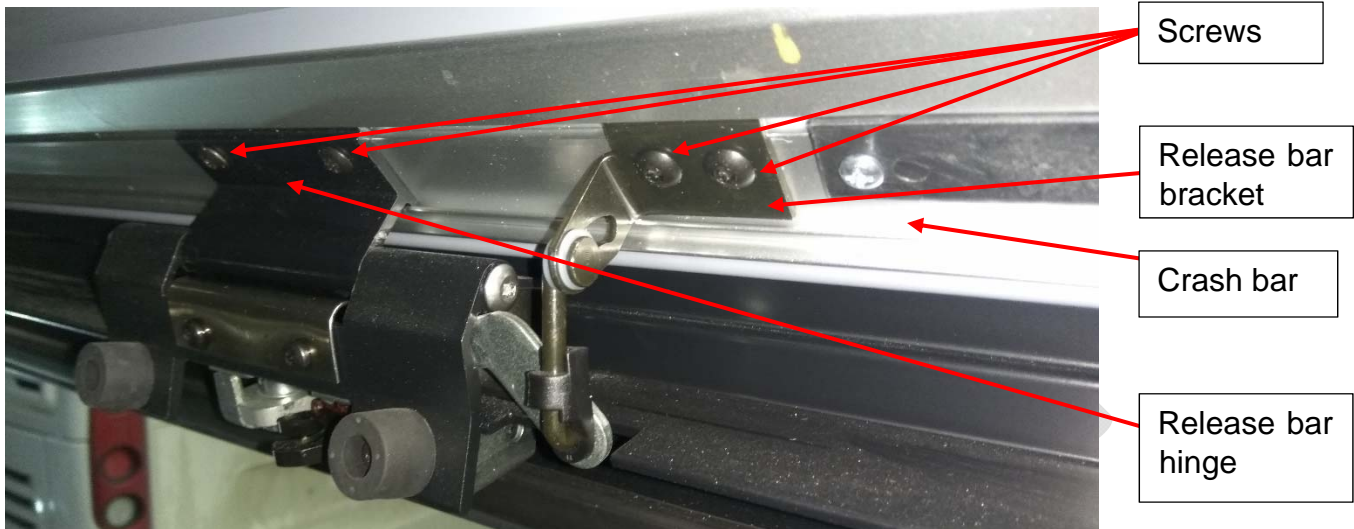

Carefully remove the wooden 2x4 installed earlier to allow the window to close.

### 3.3 Install decals

#### 3.3.1 Install decals on the RH side

Remove the rivets on the existing decals using a rivet removal gun and discard the rivets and the decals.



Clean the crash bar with isopropyl alcohol and allow 5-10 minutes of flash off time.

Position a new English decal, 03-15-7274, such that the left hole in the plate aligns with an already existing hole from the removal of the previous decals.

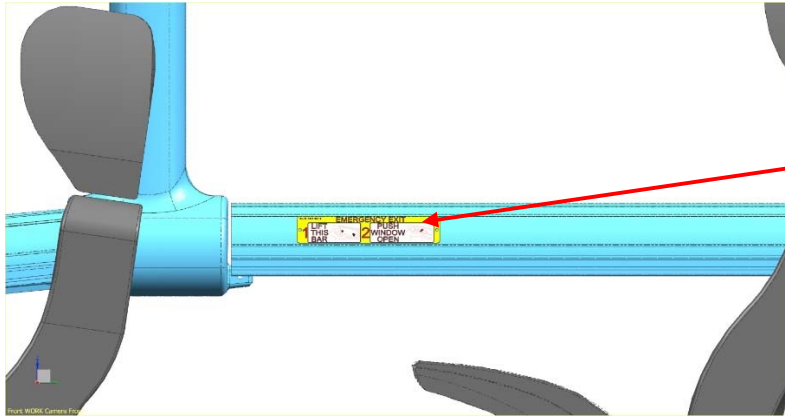

English decal

Mark the right hole of the plate in the crash bar and drill a 0.12” diameter x 0.37” depth hole. Fasten the decal using two aluminum blind rivets, 19-13-24, at the two holes.

Position the Spanish decal, 03-15-7276, if a US coach, or the French decal, 03-15-7275, if a Canadian coach, next to the English decal and mark the holes on the crash bar.

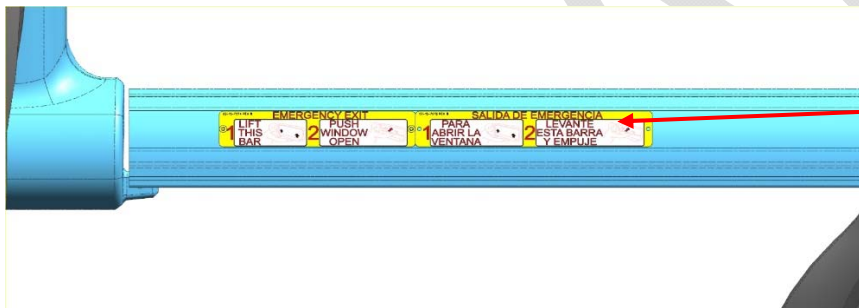

Spanish decal

Drill two 0.12” diameter x 0.37” depth holes and fasten the decal using two aluminum blind rivets, 19-13-24.



Blind rivets

Spanish decal

### 3.4.2 Install decals on the LH side

Remove the rivets on the existing decals using a rivet removal gun and discard the rivets and the decals.

Clean the crash bar with isopropyl alcohol and allow 5-10 minutes of flash off time.

Position a new English decal, 03-15-7274, such that the right hole in the plate aligns with an already existing hole from the removal of the previous decals.

Mark the left hole of the plate in the crash bar and drill a 0.12" diameter x 0.37" depth hole. Fasten the decal using two aluminum blind rivets, 19-13-24, at the two holes.

Position Spanish decal, 03-15-7276, if a US coach, or French decal, 03-15-7275, if a Canadian coach, next to the English decal and mark the holes on the crash bar.

Drill two 0.12" diameter x 0.37" depth holes and fasten the decal using two aluminum blind rivets, 19-13-24.

### 3.4.3 Install decals on the ABS post cover

Locate the ABS post cover between the newly converted egress window and the adjacent egress window.

Clean it with isopropyl alcohol and allow 5-10 minutes of flash off time.

Position and align the Emergency Exit English nameplate, 03-15-7274, as shown in the figure below.

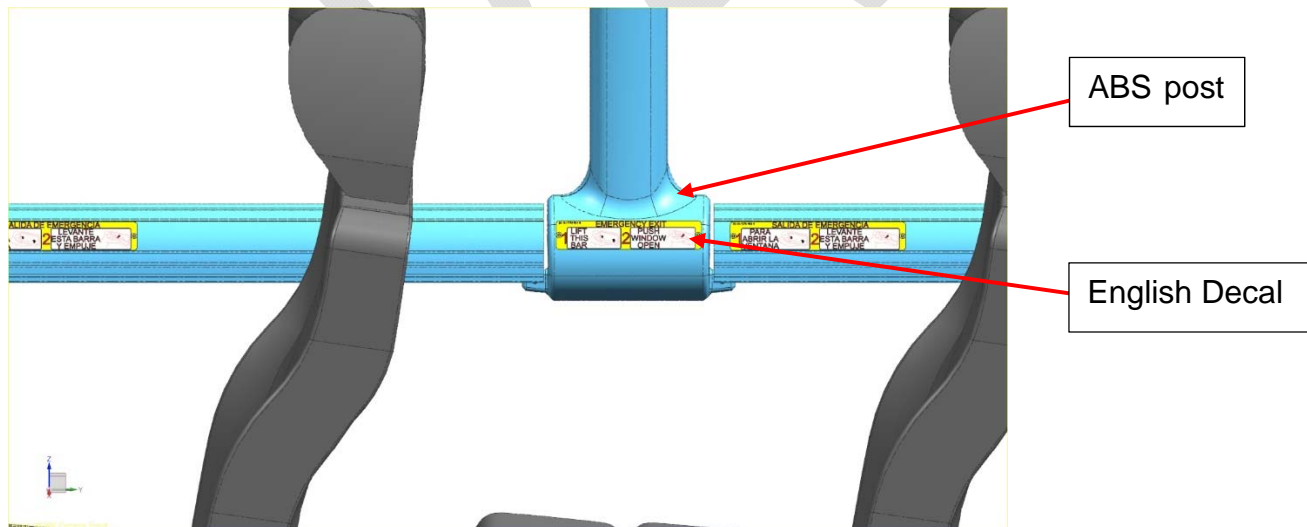

Mark the holes on the post cover and drill 0.12" diameter x 0.37" depth holes.

Secure the nameplate to the ABS post cover using aluminum blind rivets, 19-13-24.



### 4.0 Test the new Egress window

Secure the hook at the top of the Imada push/pull scale. Attach the hook to the center bottom of the crash bar and pull upward.

Verify the reading to push/pull scale. A minimum of 12lbs and no more than 19lbs is required to close sash tight and snug.

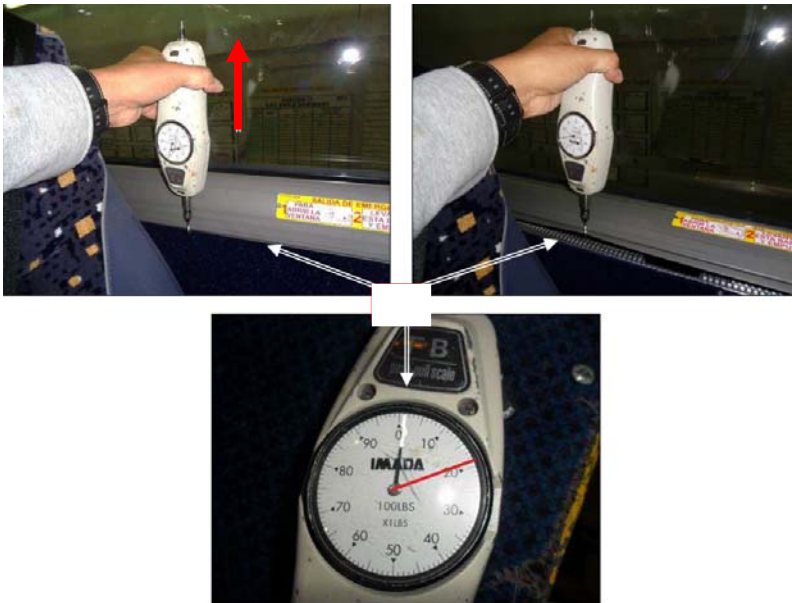

Torque the screws on the sash-cam brackets to 5 Ft-Lbs. until the bracket is solid in position.

- If the reading is above the maximum required 19lbs loosen the 2 screws of sash-cam as illustrated below; push the cam bracket outward and re-tighten the 2 screws.
- If the reading is below minimum 12lbs loosen the 2 screws of sash-cam as illustrated; push the cam bracket inward and re-tighten the 2 screws.

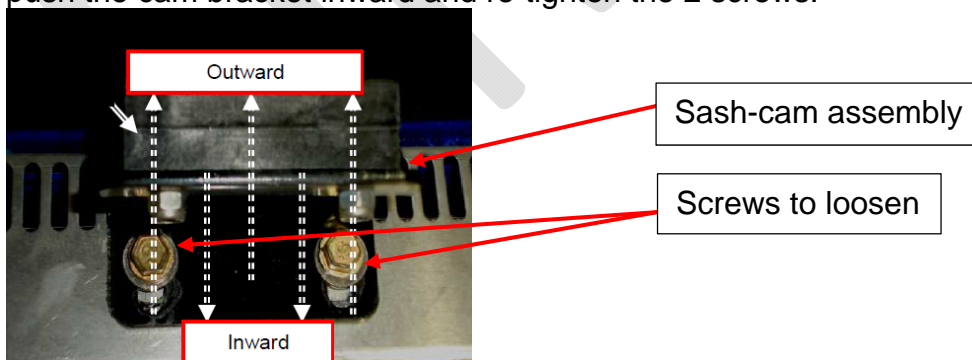

Torque the screws on the sash-cam brackets to 5 Ft-Lbs. until the bracket is solid in position.



## 5.0 Field Change Program Conditions:

The parts required for this change will be supplied without charge.

A labor allowance of 5 hours will be granted for rework of the window on affected J series coaches.

This labor allowance will be credited to your MCI Fleet Support Parts Account on receipt of the attached "MCI Field Change Program Verification Form" and a "Warranty Claim Form" as detailed in your Owner Warranty manual to MCI's Warranty department. An "MCI Field Change Program Verification Form" needs to be submitted for each VIN affected. Photocopy the attached "MCI Field Change Program Verification Form" as required for the number of affected coaches in your fleet.

Motor Coach apologizes for any inconvenience resulting from this campaign but urges you to implement this change as soon as possible.

Sincerely,

Motor Coach Industries

DRAFT



### 5.1 MCI FIELD CHANGE PROGRAM (FCP) VERIFICATION

CONTACT INFORMATION	
<b>CUSTOMER NAME:</b> _____  (PLEASE PRINT)	
FCP INFORMATION – ONE FORM PER UNIT	
<b>FCP#:</b> _____ _____	<b>Coach Model</b> _____ <b>Model Year</b> _____
<b>COACH SERIAL #:</b> (At least the last 5 digits)	<b>DATE COMPLETED</b> __ / __ / __
<b>MILEAGE:</b>	
<b>IMPORTANT: TO RECEIVE CREDIT FOR ANY ALLOWABLE LABOR CHARGES, THIS VERIFICATION FORM MUST BE RETURNED TO MCI UPON COMPLETION OF THE FCP.</b>	
<b>SUBMITTED BY: (Please Print)</b> _____  / __ / __ <span style="float: right;">DATE</span> _____	
<b>TITLE: (Please Print)</b> _____	
<b>SIGNATURE:</b> _____	
<b>COMMENTS:</b>   	



**FAX TO: 800-360-8886**

Mail or fax the completed limited warranty claim form and verification form to MCI's warranty department, or photocopy and mail to:

**MCI Fleet Support**

**Attn: Warranty Department**

**7001 Universal Coach Drive Louisville, KY 40258**

**Fax Number 1-800-360-8886**

To receive credit for the hours used to complete this task. Contact the MCI Fleet Support Technical Center at 1-800-241-2947 for any further information.