

OCT 17 2018

OCT 23 2018

Compliance Dept.

Compliance Dept.

SERVICE PROCEDURE

18512

OCTOBER 2018

SUBJECT: SAFETY RECALL

Spring Brake Chambers on certain International® DuraStar®, HV® Series, HX® Series, LoneStar®, LT® Series, MV™ Series, ProStar®, RH™ Series, and WorkStar® trucks; IC Bus® CE, FBC, and FE chassis and IC Bus® HC, RE and SFC commercial buses built 19 June 2018 through 26 July 2018 with feature code 04NDB or 04NDH (long stroke brake chamber and spring actuated parking brake).

DEFECT DESCRIPTION

The spring actuated parking brake chamber may have been improperly crimped to the service brake chamber section of the brake chamber assembly resulting in an air leak in the service brake and possible separation of the spring brake chamber. An air leak in the service brake and / or separation of the spring brake chamber may result in an inoperative brake on the affected wheel end resulting in an unexpected increase in stopping distance and increase the risk of a vehicle crash.

MODELS INVOLVED

This Safety Recall involves certain International® DuraStar®, HV™ Series, HX® Series, LoneStar®, LT® Series, MV™ Series, ProStar®, RH™ Series, and WorkStar® trucks; IC Bus® CE, FBC and FE chassis and IC Bus® HC, RE, and SFC commercial buses built 19 June 2018 through 26 July 2018 with feature code 04NDB or 04 NDH (long stroke brake chamber and spring actuated parking brake).

ELIGIBILITY

This procedure applies ONLY to vehicles marked in the International® Service Portal™ with Safety Recall 18512. Also complete any other open campaigns listed on the Service Portal at this time.

PARTS INFORMATION

NOTE: Order part number 2520291C91 as Critical Unit Down Order and provide the full 17-digit VIN number.

Part Number	Part Description	Quantity
2520291C91	Chamber; Brake, Spring Brake – T30/30	As Needed
2024771C1	Clip, Spring Type	As Needed

SERVICE PROCEDURE

WARNING! To prevent property damage, personal injury, and / or death, park vehicle on hard flat surface, turn the engine off, set the parking brake and install wheel chocks to prevent the vehicle from moving in either direction.

WARNING! To prevent property damage, personal injury, and / or death, if the vehicle must be raised, do not work under the vehicle supported only by jacks. Jacks can slip or fall over.

WARNING! To prevent personal injury and / or death, always wear safe eye protection when performing vehicle maintenance.

WARNING! To prevent property damage, personal injury, and / or death, keep flames or sparks away from vehicle and do not smoke while servicing the vehicle's batteries. Batteries expel explosive gases.

1. Park vehicle on flat surface with wheels straight ahead.
2. Shift transmission to Park or Neutral and set parking brake.
3. Install wheel chocks.

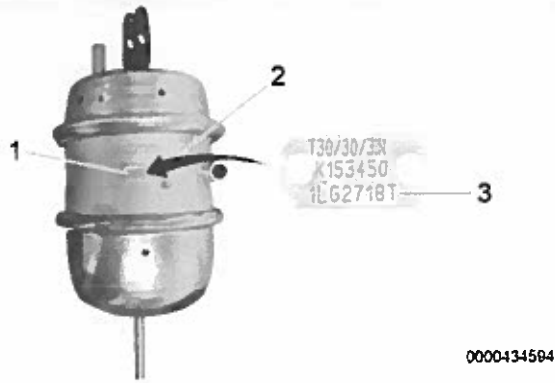

Figure 1. Spring Brake Assembly

1. Identification tag
2. Spring brake assembly
3. Lot number

NOTE: All rear axle(s) spring brake chamber assemblies will require inspection.

NOTE: Paint might be covering the metal tag, carefully remove the paint so the lot number remains intact.

4. Inspect rear axle(s) spring brake assemblies (Figure 1, Item 2) for suspect lot numbers (Figure 1, Item 3) 1LF1818T or 2LF1818T found on identification tag (Figure 1, Item 1).
 - a. If no spring brake assembly is marked with lot number 1LF1818T or 2LF1818T, proceed to Step 27.
 - b. For each spring brake assembly marked with lot number 1LF1818T or 2LF1818T, proceed to Step 5.
5. Verify adequate vehicle air system pressure and move hand valve on dash to release parking brake.
6. Fully cage spring brake chamber requiring replacement on vehicle. Refer to appropriate Bendix Service Bulletin for detailed instructions.
7. Move hand valve on dash to set parking brake.

NOTE: The image below is for representation only, there may only be one clevis pin on some vehicles.

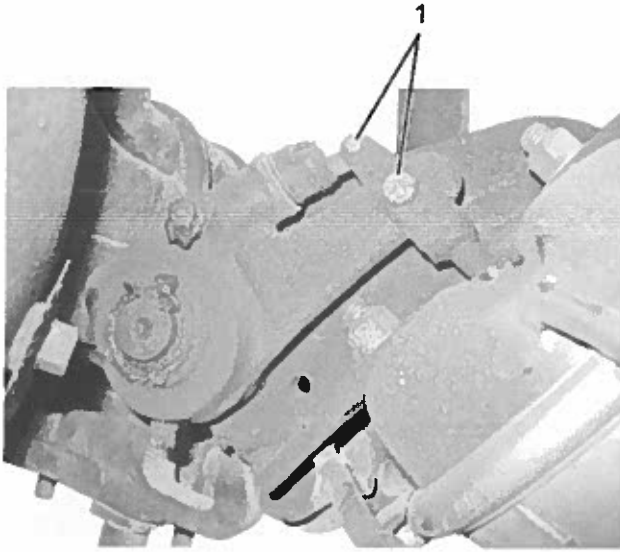

D000374324

Figure 2. Clevis Pins

1. Clevis pin (2)

8. Remove spring clip and clevis pin (Figure 2, Item 1) from yoke. Retain clevis pin for reuse.

NOTE: Be sure to mark air line from air inlet port marked "Spring" for installation reference.

9. Record orientation of air inlet ports on chamber to air system valves.

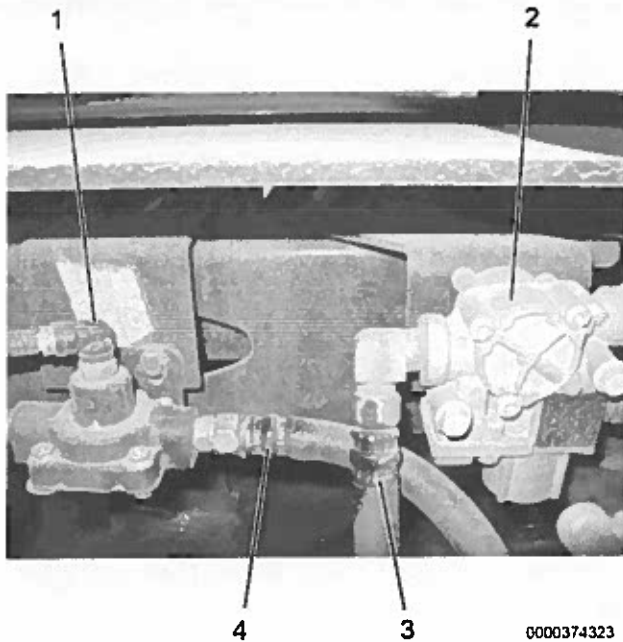

Figure 3. Valve and Hose Removal

1. Quick release valve
 2. ABS modulator valve
 3. Service brake hose
 4. Spring brake hose
10. Disconnect chamber spring brake hose (Figure 3, Item 4) from quick release valve (Figure 3, Item 1).
 11. Disconnect chamber service hose (Figure 3, Item 3) from Antilock Brake System (ABS) modulator valve (Figure 3, Item 2).
 12. Remove two spring brake chamber mounting hex nuts from spring brake assembly and remove spring brake chamber assembly from chassis.
 13. Remove spring brake and service brake hoses from spring brake chamber assembly.
 14. Apply thread sealant to brake hose threads on both hoses.
 15. Install spring brake and service brake hoses to their correct ports.

NOTE: If the replacement chamber is not caged, it must be caged prior to installing the chamber.

CAUTION: To prevent property / component damage, do not use an impact wrench to tighten retaining nuts to the brake chamber.

16. Install spring brake chamber onto chassis and properly align position of chamber to chassis with air inlet ports oriented to brake system valves as noted in Step 6.
17. Install two washers and new hex nuts onto spring brake chamber assembly.
18. Using a torque wrench, tighten nuts to 145 – 175 lb-ft (197 – 237 N•m).

NOTE: The image below is for representation only, there may only be one clevis pin on some vehicles.

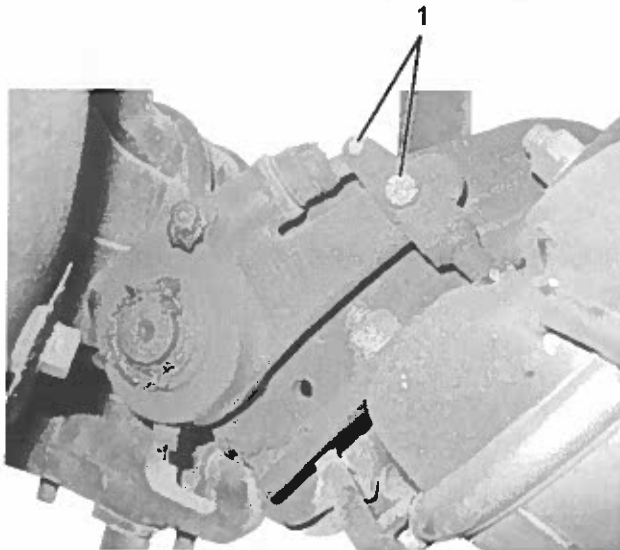

0000374324

Figure 4. Clevis Pin Installation

1. Clevis pin (2)
19. Install previously removed clevis pin (Figure 4, Item 1) and new spring clip.

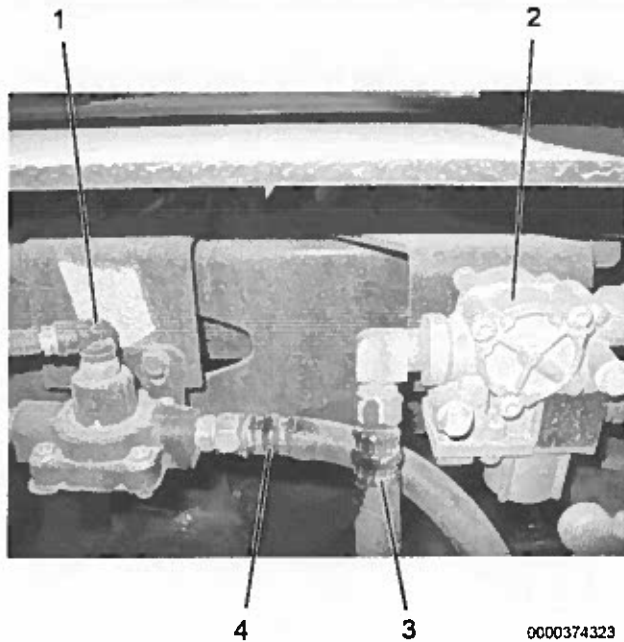

Figure 5. Valve and Hose Installation

1. Quick release valve
 2. ABS modulator valve
 3. Service brake hose
 4. Spring brake hose
20. Install chamber service hose (Figure 5, Item 3) to ABS modulator valve (Figure 5, Item 2).
 21. Install chamber spring brake hose (Figure 5, Item 4) to quick release valve (Figure 5, Item 1).
 22. Repeat Steps 5 through 24 for each additional spring brake assembly with lot number 1LF1818T or 2LF1818T.
 23. Verify adequate vehicle air system pressure and move hand valve on dash to release parking brake.
 24. Uncage all newly installed spring brake chambers according to chamber manufacturer's procedure.
 25. Adjust brake shoe to drum clearance by referring to slack adjuster manufacturer's procedures.
 26. Move hand valve on dash to set parking brake.

27. Remove wheel chocks.
28. Properly tag and store any brake chambers that have been replaced.

END OF SERVICE PROCEDURE

LABOR INFORMATION

Operation Number	Description	Time
A40-18512-1	Inspect Chamber Lot Codes; Single Axle Only	0.3 hrs
A40-18512-2	Inspect Chamber Lot Codes; Two Axles	0.4 hrs
A40-18512-3	Replace Spring Brake Assembly	0.7 hrs

CAMPAIGN IDENTIFICATION LABEL

Each vehicle corrected in accordance with this campaign must be marked with a CTS-1075 Campaign Identification Label.

Complete the label and attach on a clean surface next to the vehicle identification number (VIN) plate.



ADMINISTRATIVE / DEALER RESPONSIBILITIES

WARRANTY CLAIMS

Warranty claim expense is to be charged to Warranty. Claims are to be submitted in the normal manner, making reference to Safety Recall 18512.

Section 7 of the Warranty Policy and Procedures Manual contains further information related to the submission and processing of AFC / Recall claims.

As with all claim submissions, items acquired locally must be submitted in the "Other Charges" tab. The cost of any bulk items (such as a bag of cable tie straps, roll of wire, barrel of oil, or tube of silicone) should be prorated for the cost of the individual pieces / amount used during each repair.

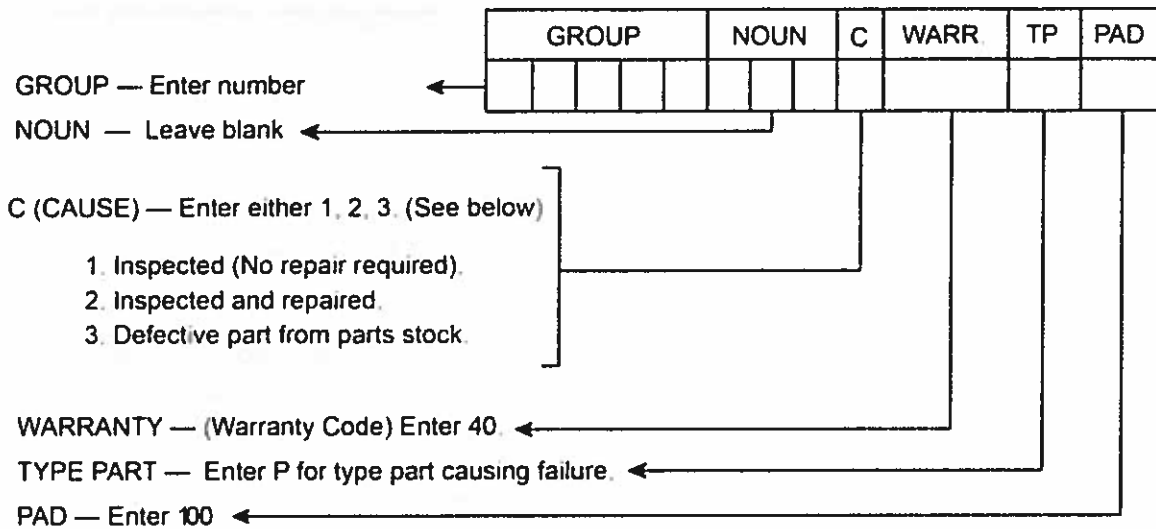

000004191C

UNITED STATES AND POSSESSIONS

The National Traffic and Motor Vehicle Safety Act, as amended, provides that each vehicle that is subject to a vehicle recall campaign must be adequately repaired within a reasonable time after the owner has tendered it for repair. A failure to adequately repair within 60 days after a tender of a vehicle is prima facie evidence of failure to repair within a reasonable time. If the condition is not adequately repaired within 60 days, the owner may be entitled to replacement with an identical or reasonable equivalent vehicle at no charge, or to a refund of the purchase price less a reasonable allowance for depreciation.

Dealers must correct all vehicles subject to this campaign at no charge to the owner, regardless of mileage, age of vehicle, or ownership, from this time forward.

Dealers should proceed immediately to make necessary correction to units in inventory. All inventory vehicles subject to this recall campaign must be corrected prior to sale, transfer or delivery. If vehicles have been sold or transferred and you are in receipt of Customer Notification Letters and Authorization for Recall Service cards for those vehicles, the transfer location or customer must be notified immediately from your dealer location.

Dealers must make every effort to promptly schedule an appointment with each owner to repair his or her vehicle as soon as possible. However, consistent with the customer notification, dealers are expected to complete the repairs on the mutually agreed upon service date.

Dealers involved in the recall process will be furnished a listing of owner names and addresses to enable them to follow up with owners and have the vehicles corrected. Use of this listing must be limited to this campaign because the list may contain information obtained from state motor vehicle registration records,

and the use of such motor vehicle registration data for purposes other than this campaign is a violation of law in several states.

CANADA

Dealers must correct all vehicles subject to this campaign at no charge to the owner, regardless of mileage, age of vehicle, or ownership, from this time forward.

Dealers should proceed immediately to make necessary correction to units in inventory. All inventory vehicles subject to this recall campaign must be corrected prior to sale, transfer or delivery. If vehicles have been sold or transferred and you are in receipt of Customer Notification Letters and Authorization for Recall Service cards for those vehicles, the transfer location or customer must be notified immediately from your dealer location.

Dealers must make every effort to promptly schedule an appointment with each owner to repair his or her vehicle as soon as possible. However, consistent with the customer notification, dealers are expected to complete the repairs on the mutually agreed upon service date.

Dealers involved in the recall process will be furnished a listing of owner names and addresses to enable them to follow up with owners and have the vehicles corrected. Use of this listing must be limited to this campaign because the list may contain information obtained from state motor vehicle registration records, and the use of such motor vehicle registration data for purposes other than this campaign is a violation of law in several states.

EXPORT

Export Distributors should proceed immediately to make necessary correction to units in inventory. All inventory vehicles subject to this recall campaign must be corrected prior to sale, transfer or delivery. If vehicles have been sold or transferred and you are in receipt of Customer Notification Letters and Authorization for Recall Service cards for those vehicles, the transfer location or customer must be notified immediately from your distributor location.

Export Distributors are to submit warranty claims in the usual manner making reference to this recall number.

Export Distributors are expected to provide full cooperation and follow-up with respect to this important subject matter. If you have any questions or need further assistance, please contact the Regional Service Manager at your regional office.

NAVISTAR, INC.