

SAFETY RECALL

Mack Trucks Inc.
Greensboro, NC USA



Date
09.2018

Number
SC0411

Page
1(04)

JOST Fifth Wheel Inspection

AN

SAFETY RECALL INFORMATION

JOST International has concluded the possibility exists of a production unit that was assembled with a prototype fifth wheel and shipped. This single (1) production unit has an incorrectly sized slider bracket that is easily detectable by following the inspection procedure outlined on page two of this document.

It is requested that trucks built between June 9, 2018 to June 29, 2018, and include one of the listed model numbers below be verified prior to use in the field due to construction quality and potential safety hazards.

NOTE: *This bulletin does not apply to MACK Trucks Australia.*

VEHICLES AFFECTED

Certain 2018 MACK AN vehicles manufactured from June 9, 2018 to June 29, 2018, and equipped with a JOST fifth wheel.

VEHICLE QUANTITY

There are 9 vehicles affected by this recall (9 U.S.).

Affected Model Numbers

- 37USA-A-002
- 37USA-A-008
- 37USL-A-002
- 37USL-A-005
- 37USL-A-008

If the inspection does result in finding the prototype fifth wheel, return the prototype fifth wheel to JOST by using the address in the Parts Disposition section of the Reimbursement table on page (4). Use the Vehicle Identification Number (VIN) to order a replacement fifth wheel and install it.

NOTE: Check the model / serial number tag locations for the affected models listed above.

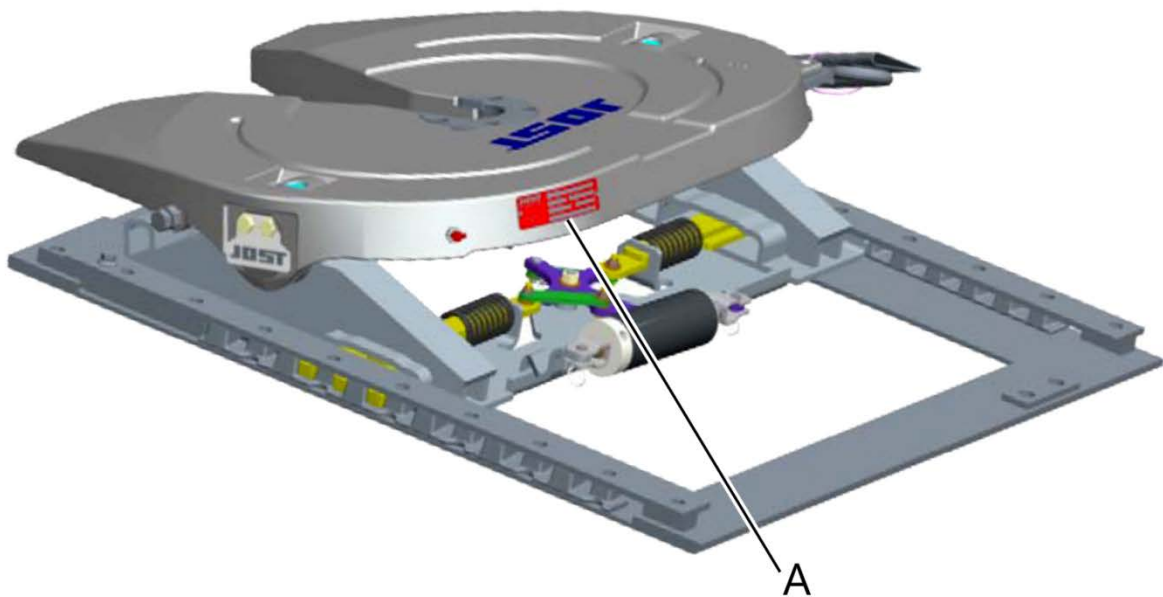

Outboard Slider Side-to-Side Clearance Inspection Procedure

1. Use a pry-bar to force the top plate bracket (B) over to one side.

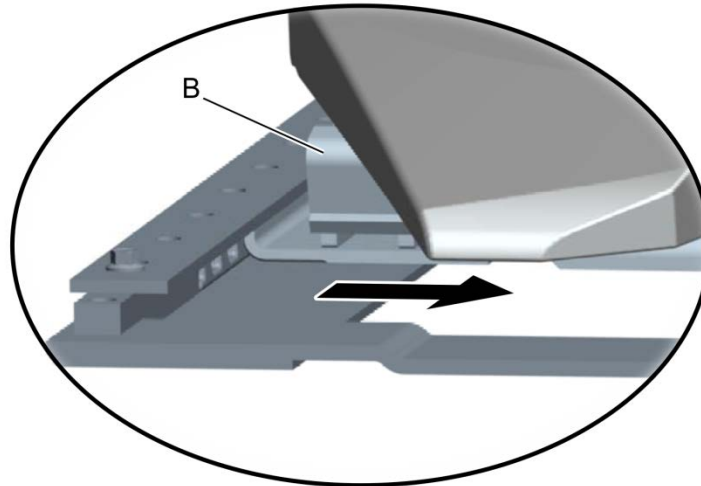

2. Place a ruler or tape measure under the cover (D) to measure the gap between the rack (C) and bracket (E). If there is a gap of 12.7mm (0.5 in) or more, the inspected JOST fifth wheel is the unit in question and should be immediately replaced.

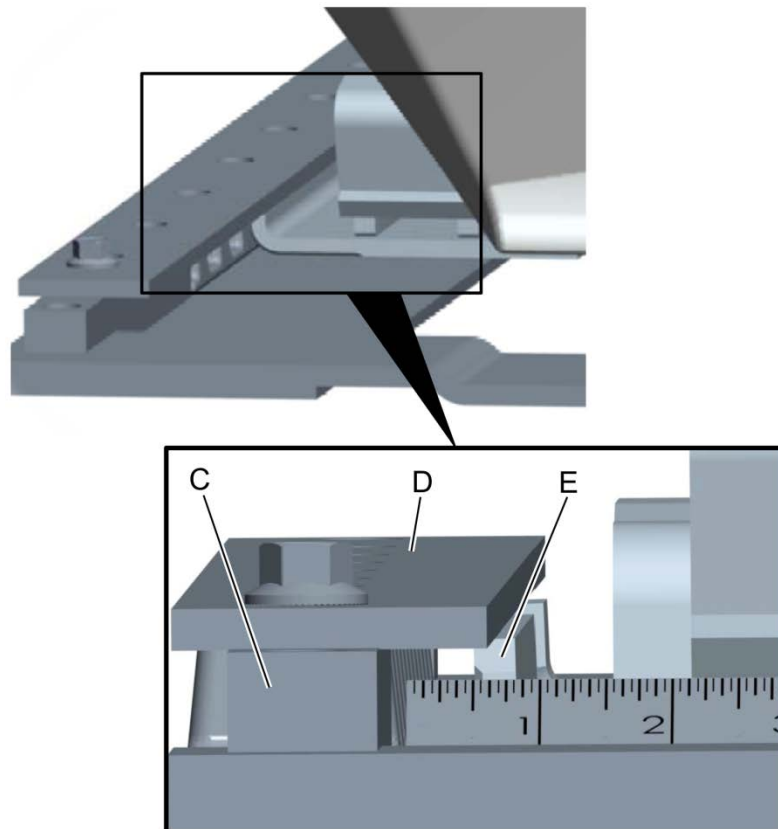

REIMBURSEMENT

This repair is covered by an authorized Safety Recall campaign. Reimbursement is obtained through the normal claim handling process.	
Claim Type (used only when uploading from the Dealer Business System)	40
Recall Status	
Vehicle repaired per instructions	
Labor Code	
Primary Labor Code, Outboard Slider Side-to Side Clearance Inspection Procedure	9222-06-09-02 0.3 hrs
Additional Labor Code, Administrative	9222-16-09-02 0.3 hrs
Additional Labor Code, JOST Fifth Wheel Replacement	9222-03-02-02 1.5 hrs
Parts Disposition	Return to: JOST International Corporation, West Andrew Johnson Hwy, Greenville, TN 37743 Phone: 1-616-846-7700
Causal Part	A8PX-Tab (12-24)
SCC Code	C6593

Note: Take Charge Time is not included in the labor code for this operation. Take charge may be eligible, but can only be used once per vehicle repair visit. If the vehicle is having other warranty repairs performed, take-charge should be charged to the warranty repair, otherwise take-charge can be charged to this Safety Recall campaign.

Note: Dealers are to perform Safety Recall Campaigns on all subject vehicles at no charge to the vehicle owner regardless of mileage, age of vehicle or ownership (original purchaser or subsequent purchasers). Whenever vehicles are subject to a safety recall are brought to your dealership for service, or taken into your dealership vehicle inventory, it is strongly recommended that every effort be made to perform the recall correction before the vehicle is sold or released to the owner.