



Safety Recall

Code: 87F9

Subject	HVAC Drain Tube/Airbag Control Module
Release Date	08/29/2018
Affected Vehicles	U.S.A. & CANADA: Certain 2018 MY Volkswagen Atlas <i>Check Campaigns/Actions screen in Elsa on the day of repair to verify that a VIN qualifies for repair under this action. Elsa is the <u>only</u> valid campaign inquiry & verification source.</i> <ul style="list-style-type: none">✓ Campaign status must show "open."✓ If Elsa shows other open action(s), inform your customer so that the work can also be completed at the same time the vehicle is in the workshop for this campaign.
Problem Description	In certain vehicles, an air conditioning evaporator (HVAC) drain tube may have been twisted during vehicle assembly. If this tube is twisted, it can lead to water draining inside the passenger compartment and also onto the airbag control module. If the airbag control module gets wet, it can malfunction and possibly lead to an unintended airbag deployment. An unintended airbag deployment can cause injuries to vehicle occupants and possibly lead to a crash.
Corrective Action	The HVAC drain tube will be inspected on all affected vehicles. If a twisted tube is found, it as well as the airbag control module will be replaced. A subset of affected vehicles (that our records show have had a twisted drain tube replaced in the past) will have the airbag control module replaced under this recall.
Precautions	A customer may notice wet carpet, a foul odor in the interior of the vehicle or the airbag warning lamp may illuminate. Other warning lights may also illuminate depending on vehicle equipment and conditions. If any of this happens, owners are advised to contact an authorized Volkswagen dealer without delay and arrange to have the vehicle inspected.
Parts Information	Please contact the Parts Specialist via phone (800-767-6552, email VWoAPartsSpecialists@vw.com) or chat/text with the VIN to order.
Code Visibility	On or about 08/29/2018, affected vehicles will be listed on the Inventory Vehicle Open Campaign Action report under My Dealership Reports (found on www.vw.com & OMD Web). A list will not be posted for dealers who do not have any affected vehicles. On or about 08/29/2018, this campaign code will show open on affected vehicles in Elsa. On or about 08/29/2018, affected vehicles will be identified with this campaign code in the VIN Lookup tool at www.vw.com and on the NHTSA VIN lookup tool at www.safercar.gov .
Owner Notification	Owner notification will take place in September, 2018. Owner letter examples are included in this bulletin for your reference.
Additional Information	Please alert everyone in your dealership about this action, including Sales, Service, Parts and Accounting personnel. Contact Warranty if you have any questions. IMPORTANT REMINDER ON VEHICLES AFFECTED BY SAFETY & COMPLIANCE RECALLS <u>New Vehicles in Dealer Inventory:</u> It is a violation of Federal law for a dealer to deliver a new motor vehicle or any new or used item of motor vehicle equipment (including a tire) covered by this notification under a sale or lease until the defect or noncompliance is remedied. By law, dealers must correct, prior to delivery for sale or lease, any vehicle that fails to comply

with an applicable Federal Motor Vehicle Safety Standard or that contains a defect relating to motor vehicle safety.

Pre-Owned Vehicles in Dealer Inventory: Dealers should not deliver any pre-owned vehicles in their inventory which are involved in a safety or compliance recall until the defect has been remedied.

Dealers must ensure that every affected inventory vehicle has this campaign completed before delivery to consumers.

Fill out and affix Campaign Completion Label (CAMP 010 000) after work is complete.

Labels can be ordered at no cost via the Compliance Label Ordering portal at www.vwhub.com.

Claim Entry Instructions

After campaign has been completed, enter claim as soon as possible to help prevent work from being duplicated elsewhere. Attach the Elsa screen print showing action open on the day of repair to the repair order.

If customer refused campaign work:

- ✓ U.S. dealers: Submit request via WISE under the *Campaigns/Update/Recall Closure* option.
- ✓ Canada dealers: Upload the repair order [signed by customer] to Volkswagen WIN/Operations/Campaign Closure.

Service Number	87F9
Damage Code	0099
Parts Vendor Code	WWO
Claim Type	Sold vehicle: 7 10 Unsold vehicle: 7 90
Causal Indicator	Mark labor as causal
Vehicle Wash/Loaner	Do not claim wash/loaner under this action

**Vehicles may have more than one criteria.
Complete and claim all applicable criteria on one claim.**

Criteria I.D.	01									
	<p>Inspect Evaporator Drain Tube, tube found ok, no further work necessary. Labor operation: 0183 00 99 25 T.U. -OR- Inspect and reattach Evaporator Drain Tube. Labor operation: 8791 05 99 25 T.U. -OR- Inspect Evaporator Drain Tube, twisted drain tube found. Replace tube, replace and program airbag control module. Labor operation: 8791 55 99 65 T.U. -AND- Labor operation: 6953 25 99 Time stated on diagnostic protocol (Max 70 T.U.)</p> <table border="1"><thead><tr><th>Quantity</th><th>Part Number</th><th>Description</th></tr></thead><tbody><tr><td>1.00</td><td>3QF820127</td><td>Evaporator Drain Tube</td></tr><tr><td>1.00</td><td>3Q0959655BN</td><td>Airbag Control Module</td></tr></tbody></table>	Quantity	Part Number	Description	1.00	3QF820127	Evaporator Drain Tube	1.00	3Q0959655BN	Airbag Control Module
Quantity	Part Number	Description								
1.00	3QF820127	Evaporator Drain Tube								
1.00	3Q0959655BN	Airbag Control Module								

Continued on next page.

Criteria I.D.	01 and 02															
	<p>Inspect and reattach Evaporator Drain Tube (if necessary) AND replace and program airbag control module.</p> <p>Labor operation: 6953 55 99 65 T.U.</p> <p>-AND-</p> <p>Labor operation: 6953 25 99 Time stated on diagnostic protocol (Max 70 T.U.)</p> <table border="1"> <thead> <tr> <th>Quantity</th> <th>Part Number</th> <th>Description</th> </tr> </thead> <tbody> <tr> <td>1.00</td> <td>3Q0959655BN</td> <td>Airbag Control Module</td> </tr> </tbody> </table> <p>-OR-</p> <p>Inspect Evaporator Drain Tube, twisted drain tube found. Replace tube, replace and program airbag control module.</p> <p>Labor operation: 8791 55 99 65 T.U.</p> <p>-AND-</p> <p>Labor operation: 6953 25 99 Time stated on diagnostic protocol (Max 70 T.U.)</p> <table border="1"> <thead> <tr> <th>Quantity</th> <th>Part Number</th> <th>Description</th> </tr> </thead> <tbody> <tr> <td>1.00</td> <td>3QF820127</td> <td>Evaporator Drain Tube</td> </tr> <tr> <td>1.00</td> <td>3Q0959655BN</td> <td>Airbag Control Module</td> </tr> </tbody> </table>	Quantity	Part Number	Description	1.00	3Q0959655BN	Airbag Control Module	Quantity	Part Number	Description	1.00	3QF820127	Evaporator Drain Tube	1.00	3Q0959655BN	Airbag Control Module
Quantity	Part Number	Description														
1.00	3Q0959655BN	Airbag Control Module														
Quantity	Part Number	Description														
1.00	3QF820127	Evaporator Drain Tube														
1.00	3Q0959655BN	Airbag Control Module														
Criteria I.D.	02															
	<p>Replace and Program Airbag Control Module</p> <p>Labor operation: 6953 55 99 65 T.U.</p> <p>-AND-</p> <p>Labor operation: 6953 25 99 Time stated on diagnostic protocol (Max 70 T.U.)</p> <table border="1"> <thead> <tr> <th>Quantity</th> <th>Part Number</th> <th>Description</th> </tr> </thead> <tbody> <tr> <td>1.00</td> <td>3Q0959655BN</td> <td>Airbag Control Module</td> </tr> </tbody> </table>	Quantity	Part Number	Description	1.00	3Q0959655BN	Airbag Control Module									
Quantity	Part Number	Description														
1.00	3Q0959655BN	Airbag Control Module														

Customer Letter Example (USA)

<MONTH YEAR>

<CUSTOMER NAME>

<CUSTOMER ADDRESS>

<CUSTOMER CITY STATE ZIPCODE>

This notice applies to your vehicle: <VIN>

NHTSA: 18V537

**Subject: Safety Recall 87F9 - HVAC Drain Tube/Airbag Control Module
2018 Model Year Volkswagen Atlas**

Dear Volkswagen Owner,

This notice is sent to you in accordance with the National Traffic and Motor Vehicle Safety Act. Volkswagen has decided that a defect, which relates to motor vehicle safety, exists in certain 2018 model year Volkswagen Atlas vehicles. Our records show that you are the owner of a vehicle affected by this action.

- What is the issue?** The HVAC drain tube will be inspected on all affected vehicles. If a twisted tube is found, the hose as well as the airbag control module will be replaced. A subset of affected vehicles (that our records show have had a twisted drain tube replaced in the past) will have the airbag control module replaced under this recall.
- What will we do?** To correct this defect, the HVAC drain tube will be inspected on all affected vehicles. If a twisted tube is found, the hose as well as the airbag control module will be replaced. A subset of affected vehicles (that our records show have had a twisted drain tube replaced in the past) will have the airbag control module replaced under this recall. This work will take less than two hours to complete and will be performed for you by your authorized Volkswagen dealer free of charge.
- What should you do?** Please contact your authorized Volkswagen dealer without delay to schedule this recall repair. To set up an appointment online, please visit www.vw.com/find-a-dealer.
- Precautions you should take** If this condition is present in your vehicle, you may notice wet carpet, a foul odor in the interior of the vehicle or the airbag warning lamp may illuminate. Other warning lights may also illuminate depending on vehicle equipment and conditions. If any of this happens, contact an authorized Volkswagen dealer without delay and arrange to have the vehicle inspected.
- Lease vehicles and address changes** If you are the lessor and registered owner of the vehicle identified in this action, the law requires you to forward this letter immediately via first-class mail to the lessee within ten (10) days of receipt. If you have changed your address or sold the vehicle, please fill out the enclosed prepaid Owner Reply card and mail it to us so we can update our records.
- Can we assist you further?** If your authorized Volkswagen dealer fails or is unable to complete this work free of charge within a reasonable time, or if you should have any questions about this communication, please reach out to us using your preferred method of communication at www.vw.com/contact or by calling us at 800-893-5298.
- Checking your vehicle for open Recalls and Service Campaigns** To check your vehicle's eligibility for repair under this or any other recall/service campaign, please visit www.vw.com/owners/recalls and enter your Vehicle Identification Number (VIN) into the Recall/Service Campaign Lookup tool.

If you still cannot obtain satisfaction, you may file a complaint with: The Administrator, National Highway Traffic Safety Administration, 1200 New Jersey Avenue, SE., Washington, DC 20590; or call the toll-free Vehicle Safety Hotline at 1-888-327-4236 (TTY: 1-800-424-9153); or go to <http://www.safercar.gov>.

We apologize for any inconvenience this matter may cause; however we are taking this action to help ensure your safety and continued satisfaction with your vehicle.

Sincerely,

Volkswagen Customer Protection

Customer Letter Example (CANADA)

<MONTH YEAR>

<CUSTOMER NAME>

<CUSTOMER ADDRESS>

<CUSTOMER CITY STATE ZIPCODE>

This notice applies to your vehicle: <VIN>

**Subject: Safety Recall 87F9 - HVAC Drain Tube/Airbag Control Module
2018 Model Year Volkswagen Atlas**

Dear Volkswagen Owner,

This notice is sent to you in accordance with the requirements of the Motor Vehicle Safety Act. Volkswagen has decided that a defect, which relates to motor vehicle safety, exists in certain 2018 model year Volkswagen Atlas vehicles. Our records show that you are the owner of a vehicle affected by this action.

What is the issue? The HVAC drain tube will be inspected on all affected vehicles. If a twisted tube is found, the hose as well as the airbag control module will be replaced. A subset of affected vehicles (that our records show have had a twisted drain tube replaced in the past) will have the airbag control module replaced under this recall.

What will we do? To correct this defect, the HVAC drain tube will be inspected on all affected vehicles. If a twisted tube is found, the hose as well as the airbag control module will be replaced. A subset of affected vehicles (that our records show have had a twisted drain tube replaced in the past) will have the airbag control module replaced under this recall. This work will take less than two hours to complete and will be performed for you by your authorized Volkswagen dealer free of charge.

What should you do? Please contact your authorized Volkswagen dealer without delay to schedule this recall repair.

Precautions you should take If this condition is present in your vehicle, you may notice wet carpet, a foul odor in the interior of the vehicle or the airbag warning lamp may illuminate. Other warning lights may also illuminate depending on vehicle equipment and conditions. If any of this happens, contact an authorized Volkswagen dealer without delay and arrange to have the vehicle inspected.

Lease vehicles and address changes If you are the lessor and registered owner of the vehicle identified in this action, the law requires you to forward this letter immediately via first-class mail to the lessee within ten (10) days of receipt. If you have changed your address or sold the vehicle, please fill out the enclosed prepaid Owner Reply card and mail it to us so we can update our records.

Reimbursement of Expenses If you have previously paid for repairs relating to the condition described in this letter, please refer to the enclosed form that explains how to request reimbursement.

Can we assist you further? If your authorized Volkswagen dealer fails or is unable to complete this work free of charge within a reasonable time, please contact Customer Relations, Monday through Friday from 8AM to 8PM EST by phone at 1-800-822-8987 or via our "Contact Us" page at www.vw.ca.

We apologize for any inconvenience this matter may cause; however we are taking this action to help ensure your safety and continued satisfaction with your vehicle.

Sincerely,

Volkswagen Customer Protection

⚠ WARNING

Risk of injury. Refer to “Warning and Safety Precautions”, found in **Appendix A** at the end of this document.

! NOTE

- Damages resulting from improper repair or failure to follow these work instructions are the dealer’s responsibility and are not eligible for reimbursement under this action.
- This procedure must be read in its entirety prior to performing the repair.
- Due to variations in vehicle equipment and options, the steps/illustrations in this work procedure may not identically match all affected vehicles.
- Diagnosis and repair of pre-existing conditions in the vehicle are not covered under this action.
- When working during extreme temperatures, it is recommended that the vehicle be allowed to acclimate inside the shop to avoid temperature-related component damage/breakage.

Repair Overview





- Inspect evaporator housing drain tube and/or replace airbag control module.
 - Criteria 01: Vehicles not included in the 40M3 or unrepaired 40M3 vehicles.
 - Criteria 01 and 02: Vehicles not included in the 40M3 or unrepaired 40M3 vehicles and an evaporator drain tube was replaced under warranty.
 - Criteria 02: Vehicles included in the 40M3 which had an evaporator drain tube replaced, but the airbag control module was not replaced.

Required Parts

<u>Criteria</u>	<u>Quantity</u>	<u>Part Number</u>	<u>Part Description</u>
01	1	3QF.820.127	Evaporator Drain Tube (if necessary)
02	1	3Q0.959.655.BN	Airbag Control Module (if necessary)

Required Tools

 <p>Torque Wrench 1783 2-10Nm -VAG1783- (or equivalent)</p>	 <p>Diagnostic Tester -VAS6150X- (or equivalent)</p>
 <p>Trim Removal Wedge -3409- (or equivalent)</p>	

Repair Instruction

Section A - Check for Previous Repair

TIP

If Campaign Completion label is present, no further work is required.

Applicable criteria ID(s)	Campaign/Action Status
01 ← 2	Open ← 1

EXAMPLE

- Enter the VIN in Elsa and proceed to the “Campaign/Action” screen.

TIP

On the date of repair, print this screen and keep a copy with the repair order.

- Confirm the Campaign/Action is open <arrow 1>. If the status is closed, no further work is required.
- Note the Applicable Criteria ID <arrow 2> for use in determining the correct work to be done and corresponding parts associated.

Vehicles with Criteria 01, or vehicles with both Criteria 01 and 02: Proceed to Section B

Vehicles with only Criteria 02: Proceed to Section C

Section B – HVAC Drain Tube Inspection

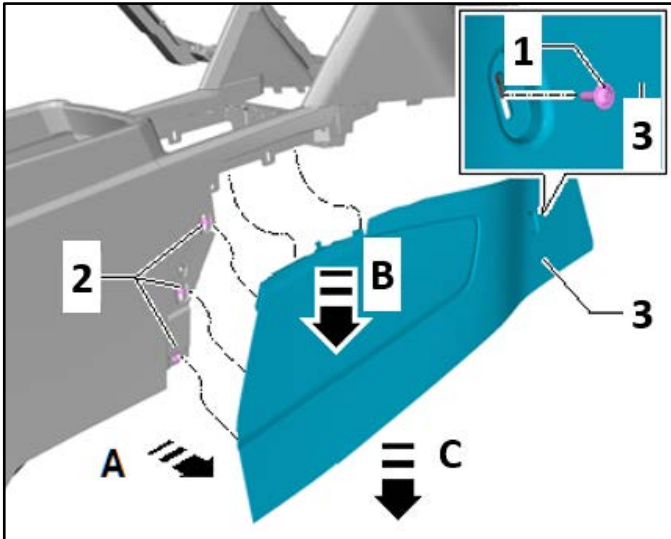

- Remove passenger side center console trim panel.
 - Remove the bolt <1>.
 - Pull down slightly at the front on the console trim.
 - Unclip the center console footwell trim panel <3> from the three center console mounts <2> <arrow A>.
 - Remove the center console footwell trim panel <3> from the center console mounts <arrows B and C>.



- Inspect the HVAC drain tube.
- If the drain tube is twisted:
 - Replace the drain tube.
 - Replace the airbag control module (**See Section C**).

WARNING

If the drain tube was found twisted, the possibility of water intrusion in the airbag control module is high. The vehicle should not be driven until the module is replaced.



- Inspect the evaporator drain tube installation at the body.
- If the tab <circle> is not installed into the body and the drain tube is not twisted, the drain tube must be reinstalled correctly/fully.

TIP

If tube is to be reinstalled, spray water on the body or the drain tube to aid in installation.



- Inspect the evaporator drain tube connection at the evaporator housing.
- If the drain tube is only partially installed on the evaporator housing and the drain tube is not twisted, it must be reinstalled correctly/fully.

- If the drain tube is fully disconnected from the evaporator housing:
 - Reattach the drain tube.
 - Replace the airbag control module (**See Section C**).

⚠ WARNING

If the drain tube was found disconnected, the possibility of water intrusion in the airbag control module is high. The vehicle should not be driven until the module is replaced.



If vehicle also has Criteria 02 open, Proceed to Section C.

If vehicle has only Criteria 01:

- Reinstall the passenger side center console trim panel and torque bolt <1> to 1.5 Nm.
- Proceed to Section D.

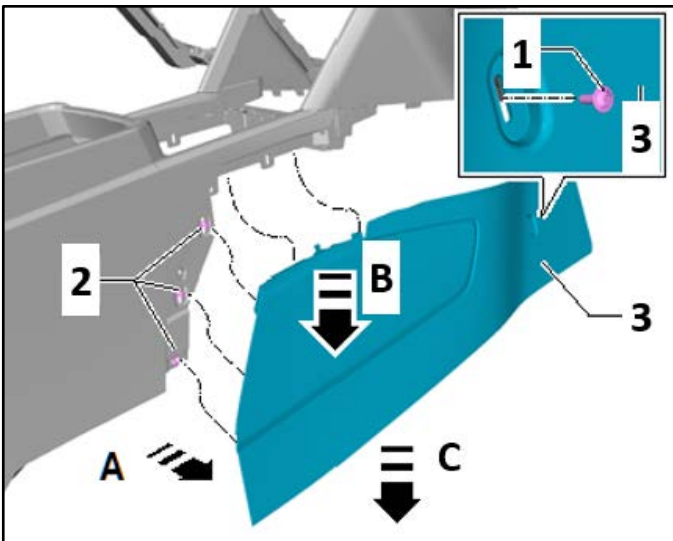

Section C – Airbag Control Module Replacement

WARNING

Accident risk. When working on pyrotechnic components (such as airbags and belt tensioners), the battery must be disconnected with the ignition switched **ON**.

- Turn **ON** the ignition.
- Move the driver and passenger seat to the most rearward position.
- Fully recline driver and passenger seat.

CAUTION

Reclining the seats before disconnecting the battery allows for additional safety in the event Terminal 15 power is not restored when reconnecting the battery at the end of the repair.

- Open the cover <1> over the battery ground terminal post.
- Loosen the nut <3>.
- Remove and isolate the battery ground cable <2> from the battery terminal.

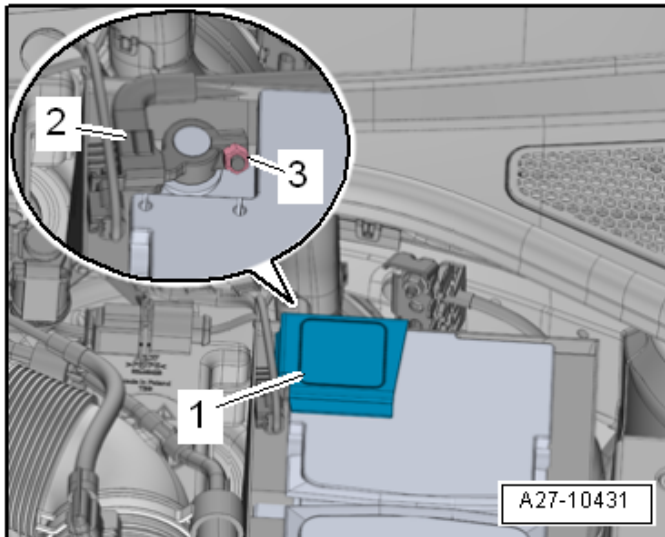

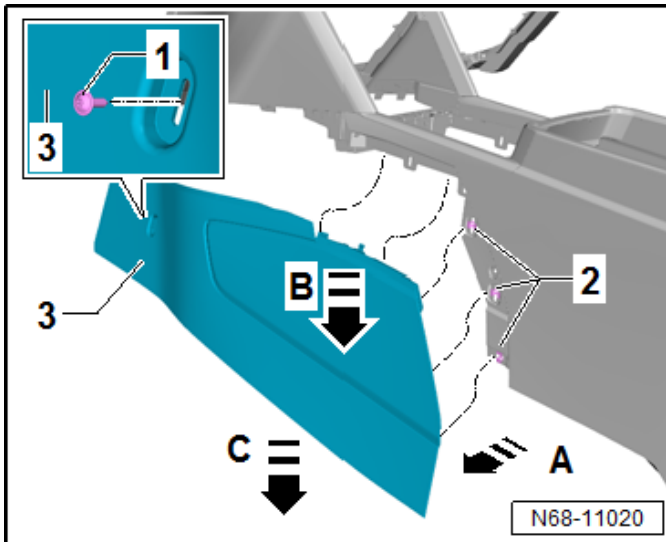

- Remove driver side center console trim panel.
 - Remove the bolt <1>.
 - Pull down slightly at the front on the console trim.
 - Unclip the center console footwell trim panel <3> from the three center console mounts <2> <arrow A>.
- Remove the center console footwell trim panel <3> from the center console mounts <arrows B and C>.

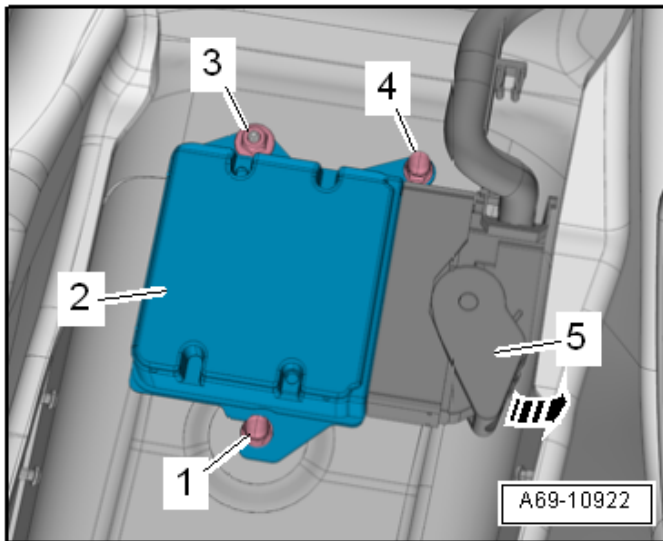

DANGER

The battery must be disconnected before proceeding. Moving the airbag control module with the battery connected could result in unintended airbag deployment.

- Remove the nut <3> in the front of the driver footwell.

WARNING

Before handling pyrotechnic components (for example, disconnecting the connector), the person handling it must “discharge static electricity”. This can be done by touching the door striker, for example.

- Disconnect the connector in the front passenger footwell by releasing the connector safety catch and opening the locking clip <5> on the connector <arrow>.
- Remove the nuts <1 and 4>.
- Carefully lift the airbag control module <2> from the threaded pins and remove it toward the passenger side.

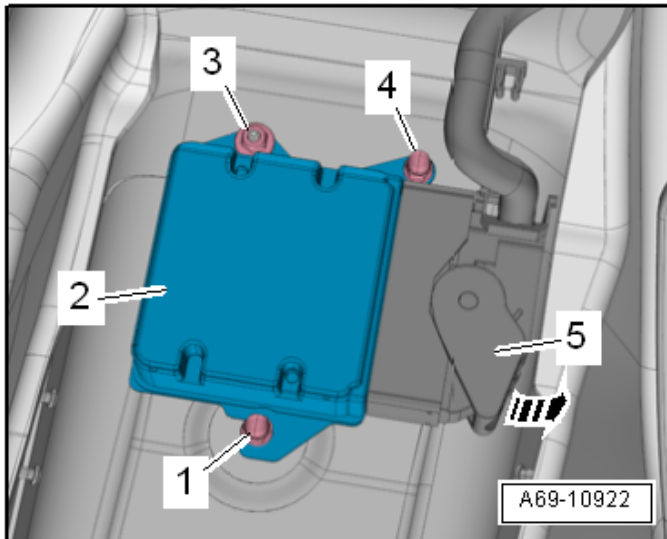

- Ensure the threads on the fasteners and studs are free of paint and dirt.

NOTE

Nut and ground pin serve as a ground connection for the control module.

- Install new airbag control module.

Part Number	Part Description
3Q0.959.655.BN	Airbag Control Module

- Install nuts <1, 3 and 4> and torque to 9 Nm.
- Connect connector <5>.

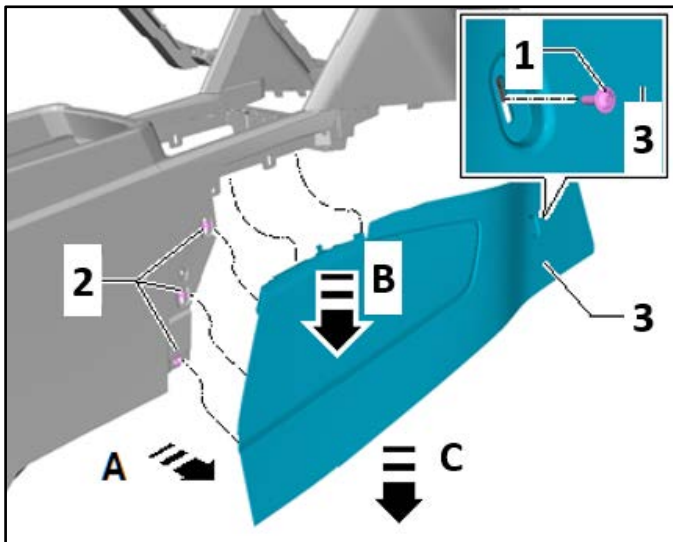

- Install the driver and passenger side center console trim panels and torque bolt <1> to 1.5 Nm.

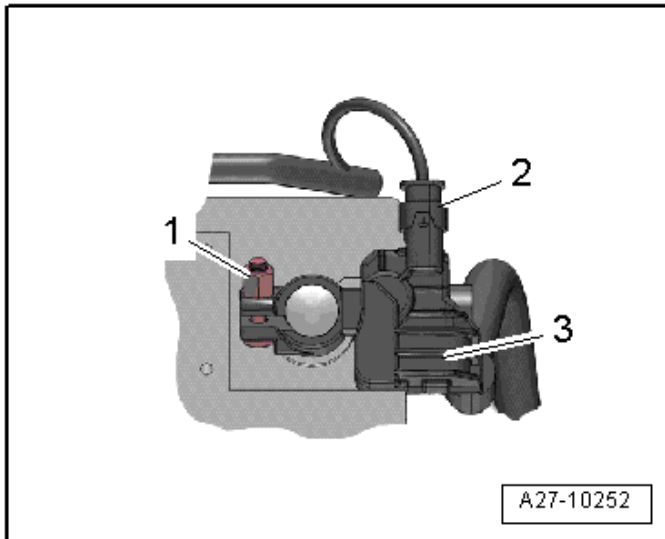

⚠ WARNING

Ignition must be **ON** when connecting battery. If pyrotechnic components (e.g. airbag, belt tensioner) are not repaired correctly, they may deploy unintentionally after connecting battery. There must not be anyone inside the vehicle when connecting the battery.

- Disconnect the connector <2> from the Battery Monitoring Control Module -J367- <3>.
- Attach the battery ground cable clamp by hand to the battery negative terminal and torque the nut <1> to 6 Nm.
- Reconnect the connector to the Battery Monitoring Control Module -J367-.
- Cycle the ignition off and back on.
- Bring driver and passenger seat to an upright position.
- Set clock to local time.
- Activate the convenience open/close functions.
- Connect the ODIS tester and check the DTC memories of all the control units and erase under-voltage faults if necessary.

! NOTE

- After connecting the battery and switching on the ignition, the ASR/ESP Control Lamp -K155- and Electromechanical Power Steering Indicator Lamp light up continuously. The indicator lamps switch off automatically after driving a short distance (less than 100 meters). This activates Steering Angle Sensor -G85-.
- Once -G85- is activated and the ignition is cycled, the Start/Stop function will also start working again and any faults related to the battery being disconnected should be able to be cleared.

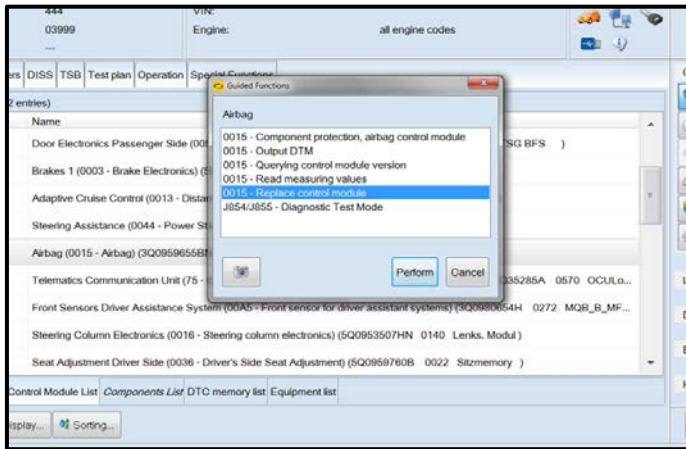

- Perform the Guided Functions test plan “0015 – Replace control module” for the new airbag control module.

NOTE

Some of the test plan operations (i.e. sending the diagnostic protocol) may appear to “stall”. Be patient while the operation completes.

Proceed to Section D.

Section D – Campaign Completion Label

Install Campaign Completion Label

- Fill out and affix Campaign Completion Label, part number CAMP 010 000, next to the vehicle emission control information label.

TIP

Ensure Campaign Completion Label does not cover any existing label(s).

Proceed to Section E.

Section E - Parts Return/Disposal

Properly store (retain), destroy or dispose of removed parts in accordance with all state/province and local requirements, unless otherwise indicated and/or requested through the Warranty Parts Portal (WPP) for U.S. and the Part Destruction and Core Disposition Report for Canada.

WARNING

General Safety Precautions when Working with Pyrotechnic Components:

- Pyrotechnic components always contain propellant that generates a gas during combustion. In some components, there is also a supply of pressurized gas to ensure this gas is generated
- This pressurized gas is stored under high pressure in a compressed gas container. Pyrotechnic components are triggered by electrical/mechanical igniters.
- Only trained personnel should perform testing, assembly and servicing work. Airbags do not have a replacement interval.
- Never check with test lamps, voltmeter or ohmmeters.
- Only check pyrotechnic components when they are installed in the vehicle using vehicle diagnosis, testing and information systems approved by the manufacturer.
- When working on pyrotechnic components and the airbag control module, disconnect the battery ground strap while the ignition is switched on. Then cover the negative terminal.
- Wait 10 seconds after disconnecting the battery.
- The ignition must be SWITCHED ON when connecting the battery. There should not be anyone inside the vehicle when doing this.
- Exception: vehicles with batteries in the passenger compartment. In this case, stay outside the range of the airbags and seat belts.
- Wash your hands after touching ignited pyrotechnic components from the restraint system.
- Do not open or repair pyrotechnic components. Use only new components to reduce the risk of injury.
- Do not install pyrotechnic components that have fallen onto a hard surface or show signs of damage.
- Discharge static electricity before handling pyrotechnic components, for example before disconnecting the electrical connector. This can be done by touching grounded metal objects such as the door striker pin.
- Install pyrotechnic components immediately after removing them from their transport packaging. If you must stop working, store the pyrotechnic component in its original transport packaging.
- Do not leave pyrotechnic components lying in the open unattended.
- Do not treat pyrotechnic components with grease, cleaning solutions or similar products.
- Do not expose pyrotechnic components to temperatures above 100 °C, even for brief periods of time.
- People in the immediate vicinity of the workplace must be protected from possible noise and projectiles.
- Pyrotechnic components can trigger unintentionally.
- In the event of unintentional deployment:
 - Single-stage inflators: allow airbag to cool down completely. Wait at least 10 minutes before handling.
 - Two-stage inflators: wait for second airbag ignition. Allow airbag to cool down completely. Wait at least 10 minutes before handling.