



## Volvo Car Customer Service

QB Instruction VCC-513520-1

<b>Title</b>	Backrest folding lock	<b>Page</b>	1 ( 10 )
<b>Action</b>	Installation	<b>Operation number:</b>	99400-2 97613-2

<b>Issue</b>	<b>Date</b>	<b>Reason</b>
1	2018-08	First issue

### Affected vehicles

<b>Model year</b>	<b>Model</b>
2019	XC40

### Materials

<b>Materials</b>	<b>Qty.</b>	<b>Part No.</b>	<b>Notes</b>
Flange nut	4.0	999127	
Lock brace	2.0	31447982	

**Orientation view**

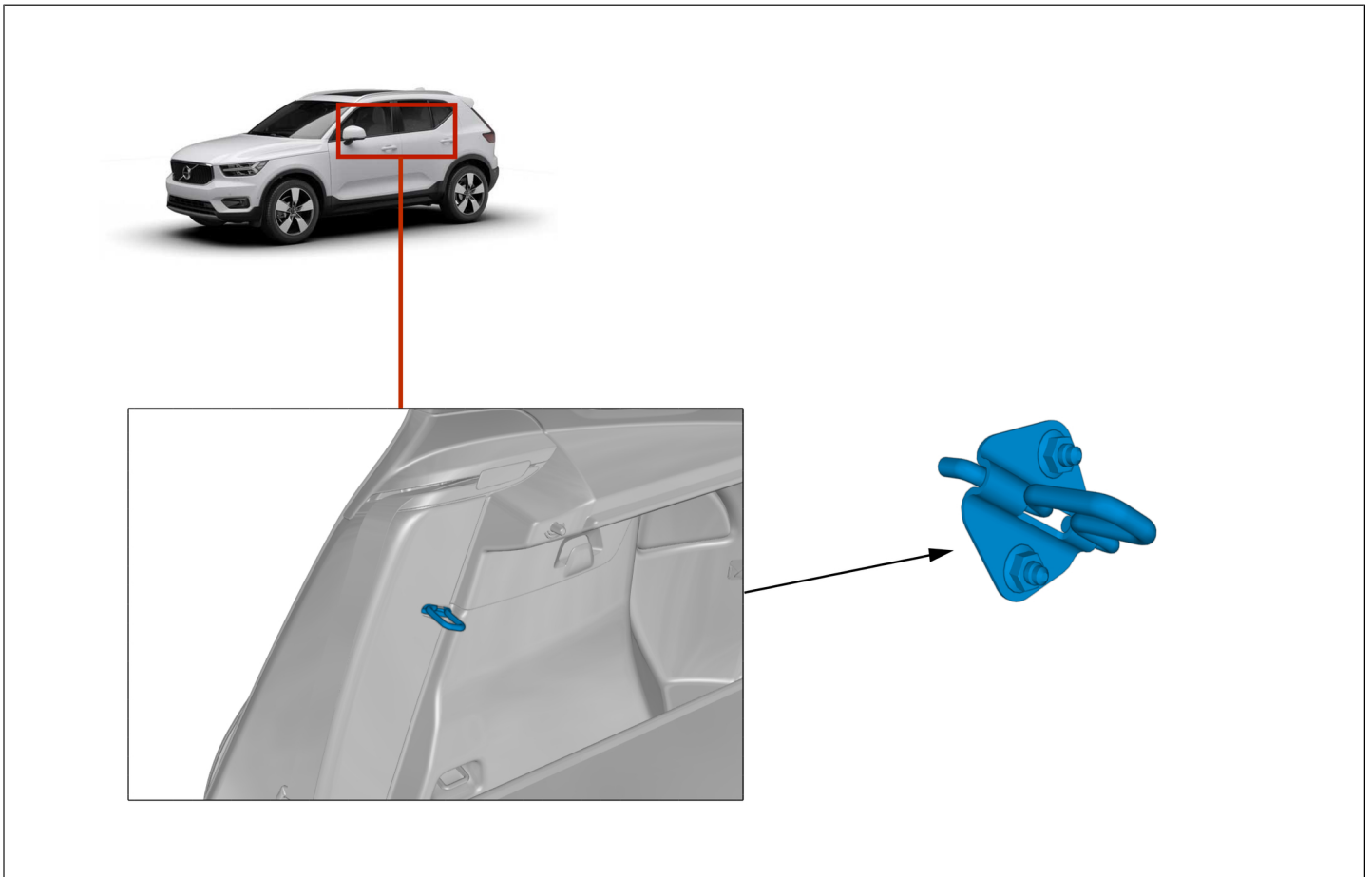

**Color symbols**

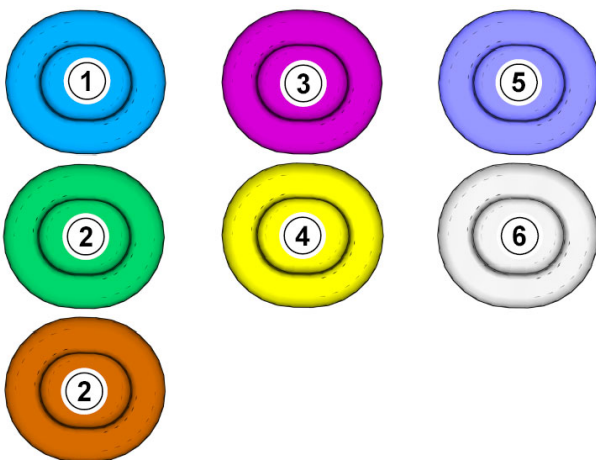

**Note! This colour chart displays (in colour print and electronic version) the importance of the different colours used in the images of the method steps.**

- 1 . Used for focused component, the component with which you will do something.
- 2 . Used as extra colors when you need to show or differentiate additional parts.
- 3 . Used for attachments that are to be removed/installed. May be screws, clips, connectors, etc.
- 4 . Used when the component is not fully removed from the vehicle but only hung to the side.
- 5 . Used for standard tools and special tools.
- 6 . Used as background color for vehicle components.

**Check**

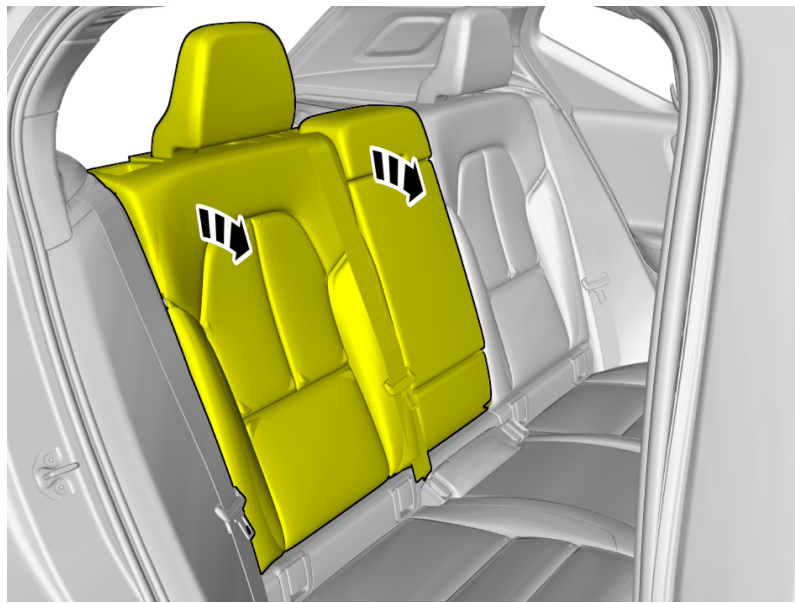

Fold marked part to one side.  
Repeat on the other side.

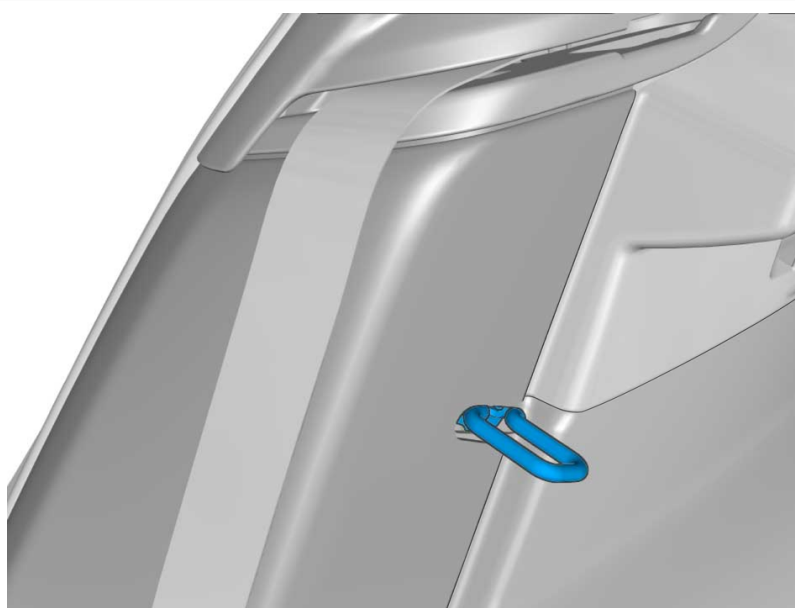

The graphic shows the correct design.  
On both sides.

Removal



Fold marked part to one side.

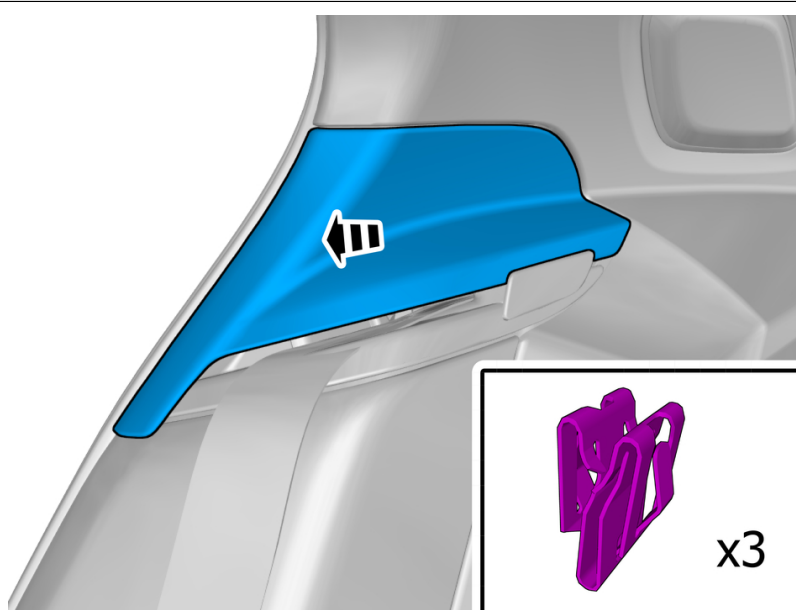

Remove the marked part.  
Use hands only.

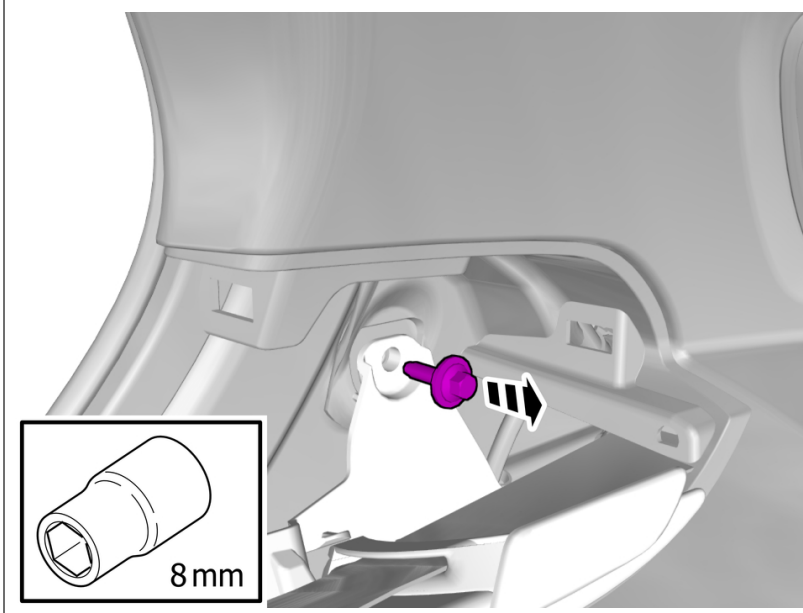

Remove the screw.

**Torque:**

Seat belt guide, to Bracket , 4.5 Nm

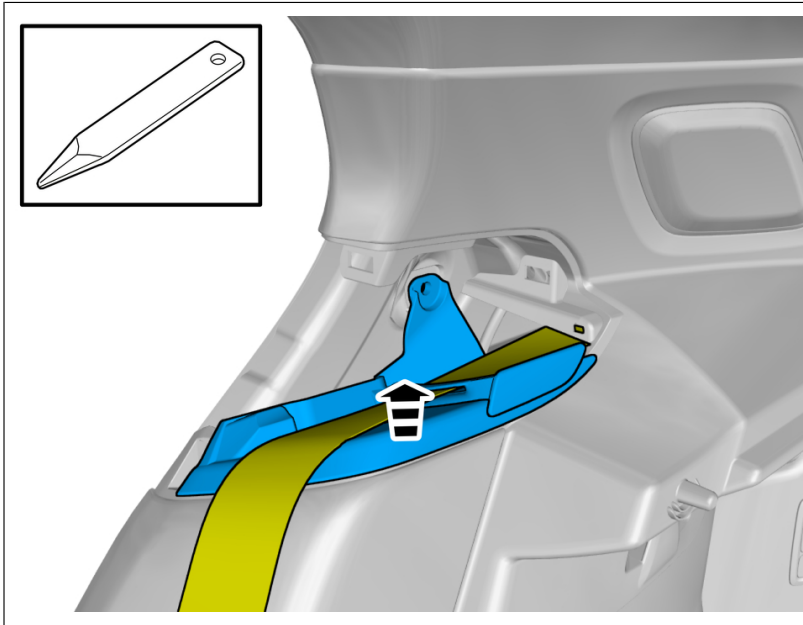

Remove the marked part.

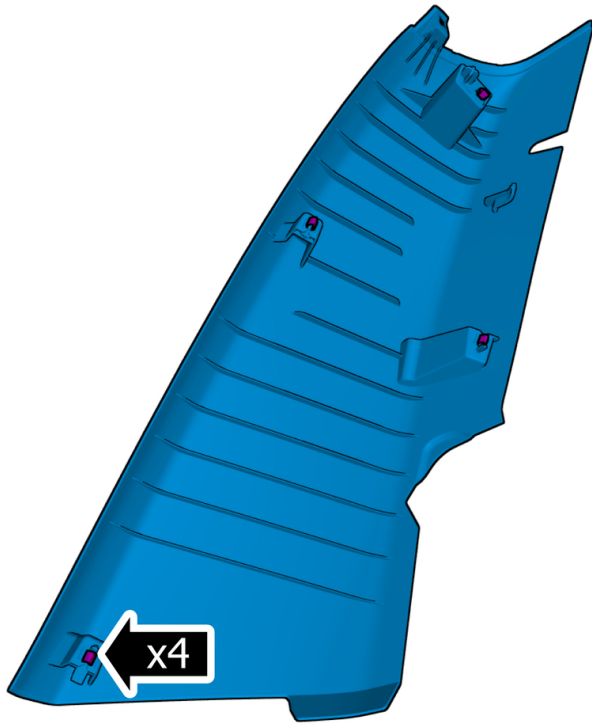

**Note!** The graphic shows the back of the component before removal.

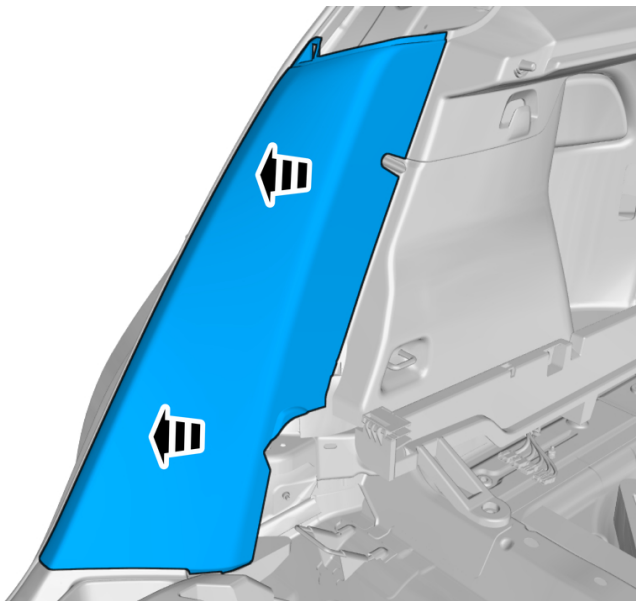

Remove the marked part.  
Use hands only.

Open the tailgate.



Loosen the marked detail.  
Repeat on the other side.

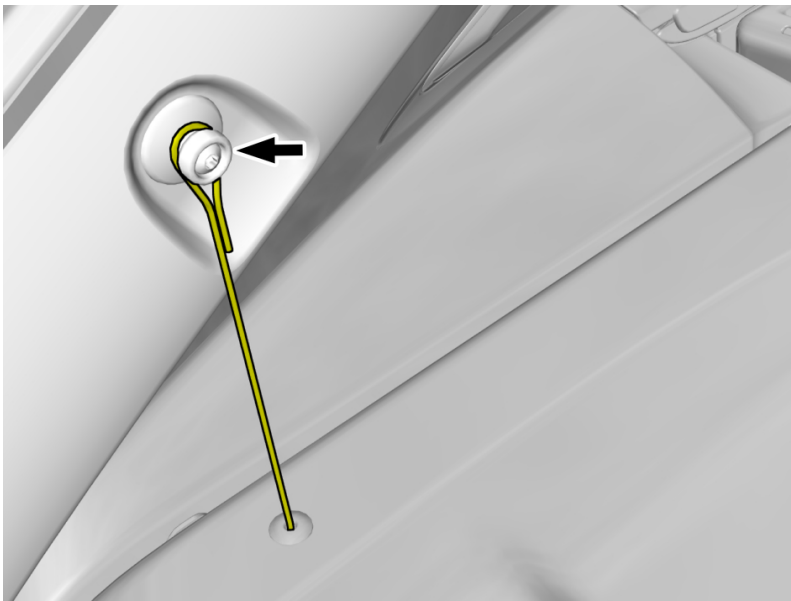

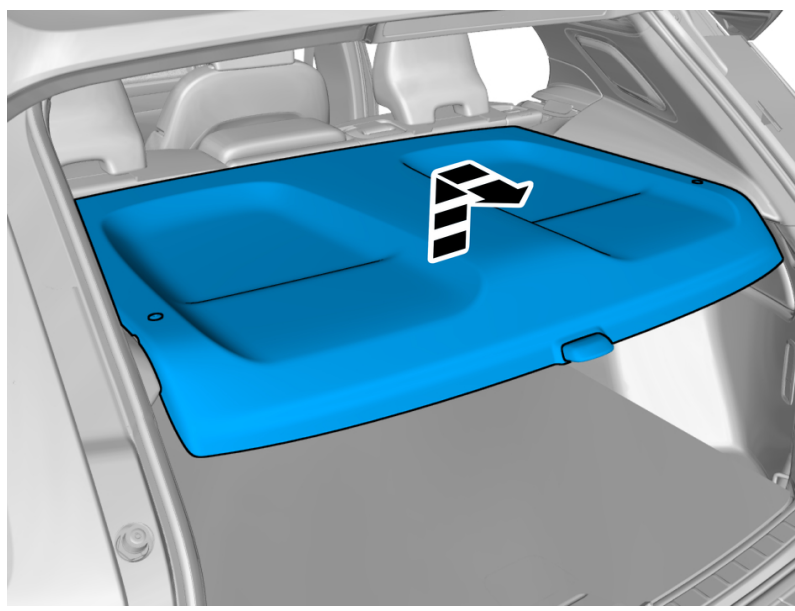

Remove the marked part.

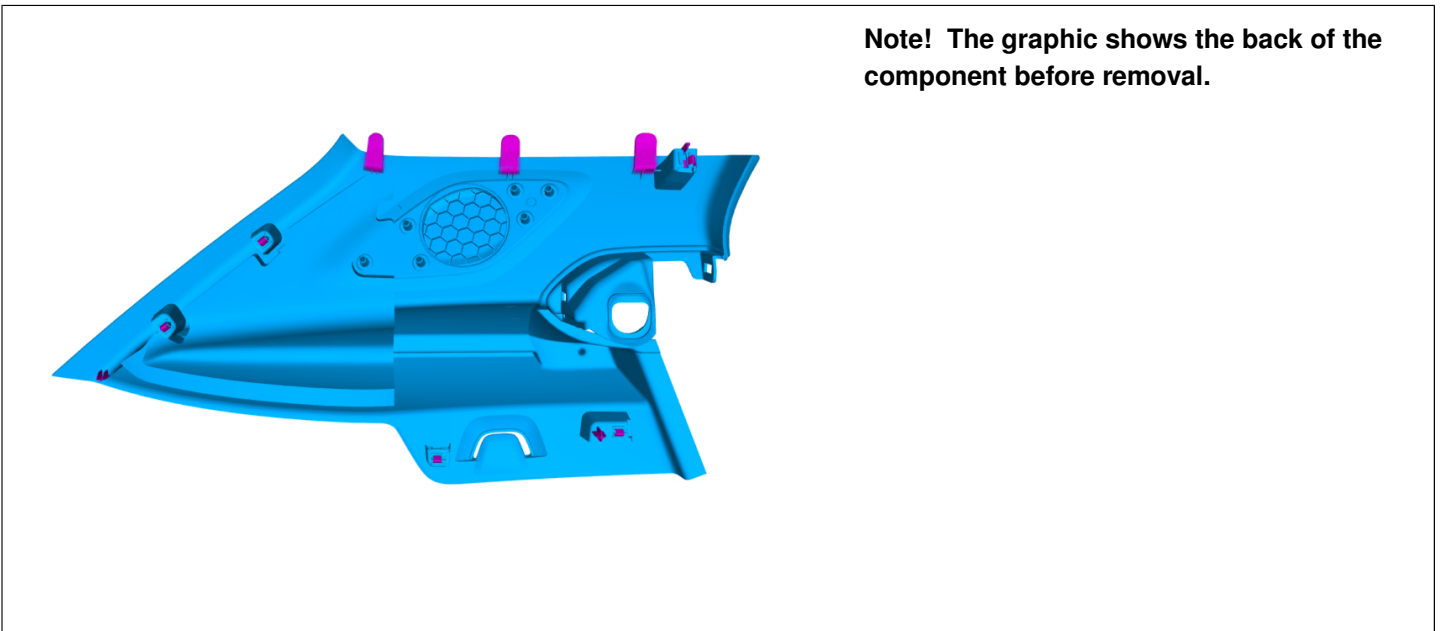

**Note!** The graphic shows the back of the component before removal.



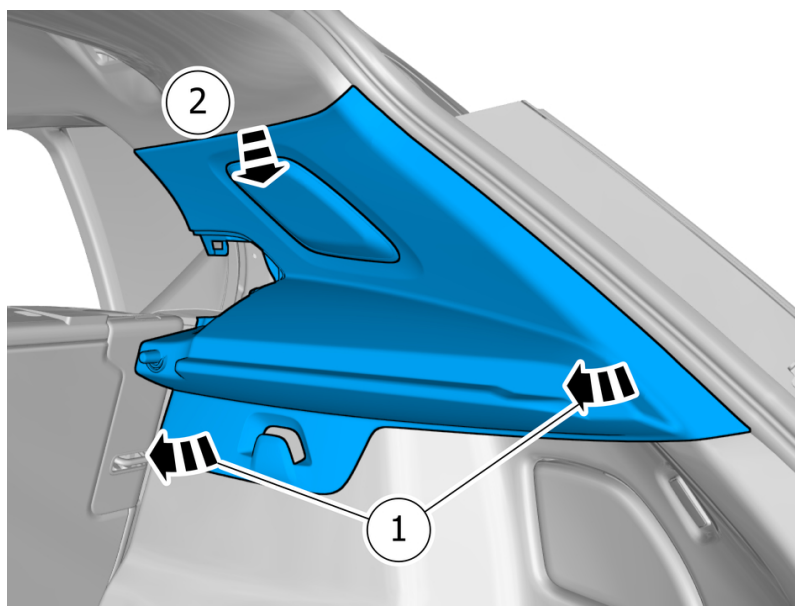

Remove the marked part.  
Use hands only.

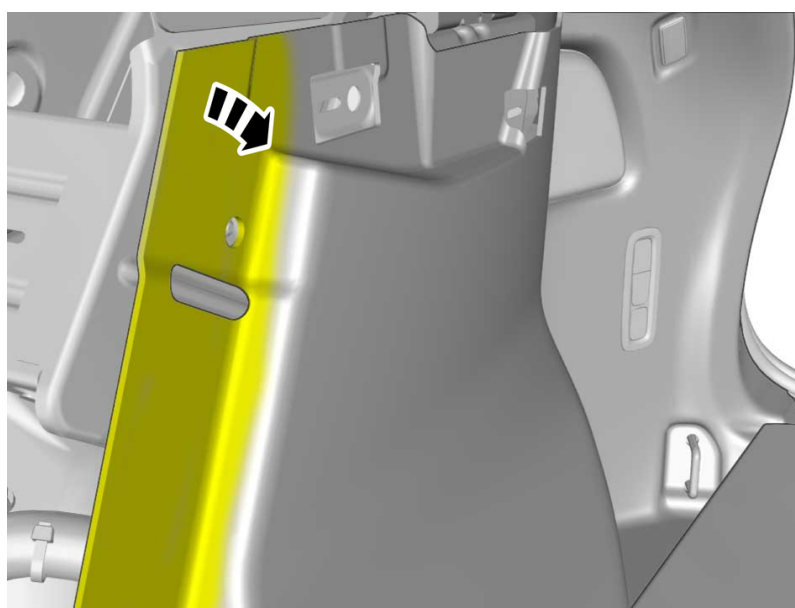

Fold marked part to one side.

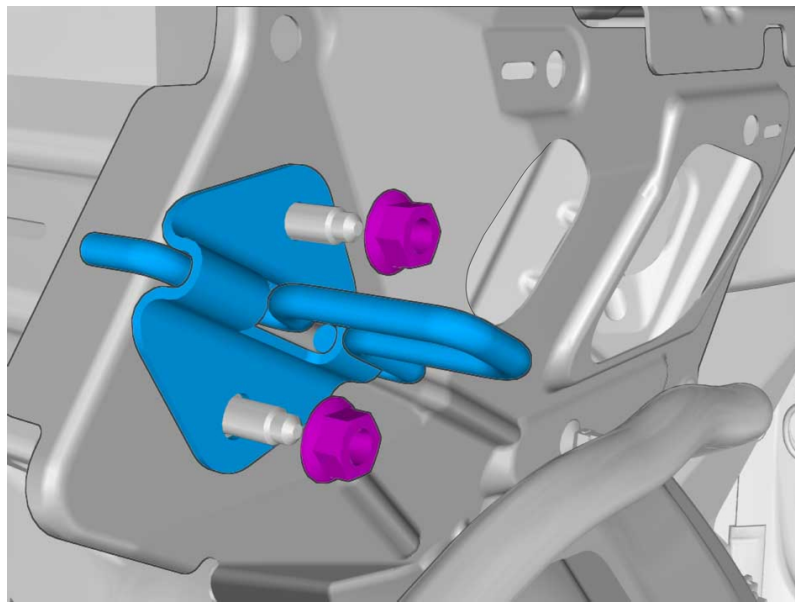
**Installation**

Install the marked component.  
Install the nuts

**Torque:**

M10 , 50 Nm

Repeat all method steps for the other side.

To install, reverse the removal procedure.