

January 2019
FL782A-S
NHTSA #18V-503
Transport Canada #18-395

Subject: Detroit Steer Axle Tie Rods

Models Affected: Specific Freightliner 114SD, Business Class M2, Cascadia, and Coronado vehicles, and Western Star 4900 vehicles manufactured July 1, 2011, through January 30, 2014.

General Information

Daimler Trucks North America LLC (DTNA), on behalf of its Freightliner Trucks Division, and its wholly owned subsidiary, Western Star Truck Sales, Inc., has decided that a defect that relates to motor vehicle safety exists on the vehicles mentioned above.

There are approximately 1,293 vehicles involved in this campaign.

Certain vehicles manufactured with Detroit front axles and Meritor brakes may generate transient brake chatter which could lead to a fatigue failure of the tie rod. Failure of the tie rod could lead to a loss of vehicle control, which could increase the risk of a crash.

For the final repair, the brake and tie rod assemblies will be replaced. **Vehicles that had the tie rod replaced for the interim repair MUST have the tie rod replaced again for the final repair.**

Additional Repairs

Dealers must complete all outstanding Recall and Field Service campaigns prior to the sale or delivery of a vehicle. A Dealer will be liable for any progressive damage that results from its failure to complete campaigns before sale or delivery of a vehicle.

Owners may be liable for any progressive damage that results from failure to complete campaigns within a reasonable time after receiving notification.

Work Instructions

Please refer to the attached work instructions. Prior to performing the campaign, check the vehicle for a completion sticker (Form WAR260).

Replacement Parts

Replacement parts are now available and can be obtained by ordering the kit and/or part number(s) listed below from your facing Parts Distribution Center.

If our records show your dealership has ordered any vehicles involved in campaign number FL782, a list of the customers and vehicle identification numbers will be available in OWL. Please refer to this list when ordering parts for this recall.

January 2019
FL782A-S
NHTSA #18V-503
Transport Canada #18-395

Table 1 - Replacement Parts for FL782

NOTE: Order the parts called out in the first section of Table 1 for all VINs in FL782A-R, plus the appropriate additional parts called out for each letter group. For FL782-S, please submit a WSC ticket to Warranty Campaigns for the parts list.

Campaign Number	Ordering Info	Part Description	Part Number	Qty.
FL782A-R	Order these parts plus those listed below for each specific group.	FL782 - BRAKE ASSY KIT	TDA KIT8342	1 ea
		SCR-CAP,HEX,LOW PF,,75-16X1.75	23-13994-175	12 ea
		SCR-CAP,HEX,LOW PF,,75-16X2.25	23-13994-225	2 ea
		WASHER-HRDN,0.81X1.13X.177,ZN	23-09114-014	16 ea
		NUT-HEX,LKG,3/4-16,GR8,ZN AL	23-13833-212	2 ea
		SEAL-OIL SXL FF .904 1 4.85OD	CHR 35058	2 ea
		PIN-COTTER,1 3/4 X 1/8	23-00800-407	2 ea
		BLANK COMPLETION STICKER	WAR260	1 ea
FL782A 327 VINs	No Dust Shield	TIE ROD ASM	MBA 6803304403	1 ea
		DRUM 1H O65TT 878 937 110 .50	CM 10014756	2 ea
FL782B 9 VINs	No Dust Shield	TIE ROD ASM	MBA 6803304403	1 ea
		DRUM 1H O65CL 878 937 128 .50	CM 10041543	2 ea
FL782C 2 VINs	No Dust Shield	TIE ROD ASM	MBA 6803304403	1 ea
		BRAKE DRUM/X30	TDA 53 123815 002	2 ea
FL782D 736 VINs	No Dust Shield	TIE ROD ASM	MBA 6803304303	1 ea
		DRUM 1H O65TT 878 937 110 .50	CM 10014756	2 ea
FL782E 17 VINs	No Dust Shield	TIE ROD ASM	MBA 6803304303	1 ea
		BRAKE DRUM/X30	CM 10041543	2 ea
FL782F 7 VINs	No Dust Shield	TIE ROD ASM	MBA 6803304303	1 ea
		BRAKE DRUM/X30	TDA 53 123815 002	2 ea
FL782G 112 VINs	No Dust Shield	TIE ROD ASM	MBA 6803303703	1 ea
		DRUM 1H O65TT 878 937 110 .50	CM 10014756	2 ea
FL782H 7 VINs	No Dust Shield	TIE ROD ASM	MBA 6803303703	1 ea
		BRAKE DRUM/X30	CM 10041543	2 ea
FL782I 2 VINs	No Dust Shield	TIE ROD ASM	MBA 6803303703	1 ea
		DRUM-16.5 X 5	HWI 600027	2 ea
FL782J 5 VINs	w/Dust Shield	TIE ROD ASM	MBA 6803304403	1 ea
		DRUM 1H O65TT 878 937 110 .50	CM 10014756	2 ea
		DUST SHIELD	TDA 3264N118	2 ea
FL782K 8 VINs	w/Dust Shield	TIE ROD ASM	MBA 6803304403	1 ea
		BRAKE DRUM/X30	CM 10041543	2 ea
		DUST SHIELD	TDA 3264N118	2 ea
FL782L 1 VIN	w/Dust Shield	TIE ROD ASM	MBA 6803304403	1 ea
		DRUM-16.5 X 5	HWI 600027	2 ea
		DUST SHIELD	TDA 3264N118	2 ea
FL782M 13 VINs	w/Dust Shield	TIE ROD ASM	MBA 6803304303	1 ea
		DRUM 1H O65TT 878 937 110 .50	CM 10014756	2 ea
		DUST SHIELD	TDA 3264N118	2 ea
FL782N 21 VINs	w/Dust Shield	TIE ROD ASM	MBA 6803303703	1 ea
		DRUM 1H O65TT 878 937 110 .50	CM 10014756	2 ea
		DUST SHIELD	TDA 3264N118	2 ea

Table 1, continues on the next page.

January 2019
FL782A-S
NHTSA #18V-503
Transport Canada #18-395

Campaign Number	Ordering Info	Part Description	Part Number	Qty.
FL782O 1 VIN	w/Dust Shield	TIE ROD ASM	MBA 6803303703	1 ea
		BRAKE DRUM/X30	CM 10041543	2 ea
		DUST SHIELD	TDA 3264N118	2 ea
FL782P 1 VIN	w/Dust Shield	TIE ROD ASM	MBA 6803303703	1 ea
		16.5X5 BRAKE DRUM	GUN 3758X	2 ea
		DUST SHIELD	TDA 3264N118	2 ea
FL782Q 1 VIN	w/Dust Shield	TIE ROD ASM	MBA 6803303703	1 ea
		DRUM-16.5 X 5	HWI 600027	2 ea
		DUST SHIELD	TDA 3264N118	2 ea
FL782R 2 VINs	w/Dust Shield Order TDA KIT8342 and these Spider Brake Assys.	TIE ROD ASM	MBA 6803304403	1 ea
		DRUM 1H O65TT 878 937 110 .50	CM 10014756	2 ea
		DUST SHIELD	TDA 3264N118	2 ea
		SPIDER-BRAKE ASY	TDA A3211Z7176	1 ea
		SPIDER-BRAKE ASY	TDA A3211A7177	1 ea
FL782S 1 VIN (Vehicle Serial: FT4889)	No Dust Shield Submit a WSC ticket to Warranty Campaigns for parts list.	—	—	—

Table 1, continued from the previous page.

Removed Parts

U.S. and Canadian Dealers, please follow Warranty Failed Parts Tracking shipping instructions for the disposition of all removed parts. Export distributors, please destroy removed parts unless otherwise advised.

Labor Allowance

Table 2 - Labor Allowance

Campaign Number	Procedure	Time Allowed (hours)	SRT Code	Corrective Action
FL782A-S	Replace tie rod and brake assys	8.8	996-R049A	12-Repair Recall/Campaign

Table 2

IMPORTANT:When the Recall has been completed, locate the base completion label in the appropriate location on the vehicle, and attach the red completion sticker provided in the recall kit (Form WAR260). If the vehicle does not have a base completion label, clean a spot on the appropriate location of the vehicle and first attach the base completion label (Form WAR259). If a recall kit is not required or there is no completion sticker in the kit, write the recall number on a blank sticker and attach it to the base completion label.

Claims for Credit

You will be reimbursed for your parts, labor, and handling (landed cost for Export Distributors) by submitting your claim through the Warranty system within 30 days of completing this campaign. Please reference the following information in OWL:

- Claim type is **Recall Campaign**.
- In the Campaign field, enter the campaign number and appropriate condition code (e.g. **FL782-A, FL782-B, etc.**).
- In the Primary Failed Part Number field, enter **25-FL782-000**.

January 2019
FL782A-S
NHTSA #18V-503
Transport Canada #18-395

- In the Parts field, enter the appropriate kit and/or part number(s) as shown in the Replacement Parts Table.
- In the Labor field, first enter the appropriate SRT from the Labor Allowance Table. Administrative time will be included automatically as SRT 939-6010A for 0.3 hours.
- The VMRS Component Code is **015-004-045** and the Cause Code is **A1 - Campaign**.
- **U.S. and Canada -- Reimbursement for Prior Repairs.** When a customer asks about reimbursement, please do the following:
 - Accept the documentation of the previous repair.
 - Make a brief check of the customer's paperwork to see if the repair may be eligible for reimbursement. (See the "Copy of Owner Letter" section of this bulletin for reimbursement guidelines.)
 - Submit an OWL Recall Pre-Approval Request for a decision.
 - Include the approved amount on your claim in the Other Charges section.
 - Attach the documentation to the pre-approval request.
 - If approved, submit a based on claim for the pre-approval.
 - Reimburse the customer the appropriate amount.

IMPORTANT: OWL must be viewed prior to performing the recall to ensure the vehicle is involved and the campaign has not been previously completed. Also, check for a completion sticker prior to beginning work.

U.S. and Canadian dealers, contact the Warranty Campaigns Department via Web inquiry at DTNACconnect.com / WSC, or the Customer Assistance Center at (800) 385-4357, after normal business hours, if you have any questions or need additional information. Export distributors, submit a Web inquiry or contact your International Service Manager.

U.S. and Canadian Dealers: To return excess kit inventory related to this campaign, U.S. dealers must submit a Parts Authorization Return (PAR) to the Memphis PDC. Canadian dealers must submit a PAR to their facing PDC. All kits must be in resalable condition. PAR requests must include the original purchase invoice number. Export Distributors: Excess inventory is not returnable.

The letter notifying U.S. and Canadian vehicle owners is included for your reference.

Please note that the National Traffic and Motor Vehicle Safety Act, as amended (Title 49, United States Code, Chapter 301), requires the owner's vehicle(s) be corrected within a reasonable time after parts are available to you. The Act states that failure to repair a vehicle within 60 days after tender for repair shall be prima facie evidence of an unreasonable time. However, circumstances of a particular situation may reduce the 60 day period. Failure to repair a vehicle within a reasonable time can result in either the obligation to (a) replace the vehicle with an identical or reasonably equivalent vehicle, without charge, or (b) refund the purchase price in full, less a reasonable allowance for depreciation. The Act further prohibits dealers from selling a vehicle unless all outstanding recalls are performed. Any lessor is required to send a copy of the recall notification to the lessee within 10 days. Any subsequent stage manufacturer is required to forward this notice to its distributors and retail outlets within five working days.

January 2019
FL782A-S
NHTSA #18V-503
Transport Canada #18-395

Copy of Notice to Owners

Subject: Detroit Steer Axle Tie Rods

For the Notice to U.S. Customers: This notice is sent to you in accordance with the National Traffic and Motor Vehicle Safety Act. **For the Notice to Canadian Customers:** This notice is sent to you in accordance with the Canadian Motor Vehicle Safety Act.

Daimler Trucks North America LLC (DTNA), on behalf of its Freightliner Trucks Division, and its wholly owned subsidiary, Western Star Truck Sales, Inc., has decided that a defect that relates to motor vehicle safety exists on specific Freightliner 114SD, Business Class M2, Cascadia, and Coronado vehicles, and Western Star 4900 vehicles manufactured July 1, 2011, through January 30, 2014.

Certain vehicles manufactured with Detroit front axles and Meritor brakes may generate transient brake chatter which could lead to a fatigue failure of the tie rod. Failure of the tie rod could lead to a loss of vehicle control, which could increase the risk of a crash.

This is the second of two notices regarding this recall. The final repair is now available and parts have been secured. The brake and tie rod assemblies will be replaced. **Vehicles that had the tie rod replaced for the interim repair MUST have the tie rod replaced again for the final repair.** Please contact an authorized Daimler Trucks North America dealer to arrange to have the Recall performed and to ensure that parts are available at the dealership. To locate an authorized dealer, go to www.Daimler-TrucksNorthAmerica.com. On the menu tab, select "Contact," scroll down to "Find a Dealer," and select the appropriate brand. The Recall will take approximately nine hours and will be performed at no charge to you.

You may be liable for any progressive damage that results from your failure to complete the Recall within a reasonable time after receiving notification.

If you do not own the vehicle that corresponds to the identification number(s) which appears on the Recall Notification, please return the notification to the Warranty Campaigns Department with any information you can furnish that will assist us in locating the present owner. If you have leased this vehicle, Federal law requires that you forward this notice to the lessee within 10 days. If you are a subsequent stage manufacturer, Federal law requires that you forward this notice to your distributors and retail outlets within five working days. If you have paid to have this recall condition corrected prior to this notice, you may be eligible to receive reimbursement. Please see the reverse side of this notice for details.

For the Notice to U.S. Customers: If you have questions about this Recall, please contact the Warranty Campaigns Department at (800) 547-0712, 7:00 a.m. to 4:00 p.m. Pacific Time, Monday through Friday, e-mail address DTNA.Warranty.Campaigns@Daimler.com, or the Customer Assistance Center at (800) 385-4357 after normal business hours. If you are not able to have the defect remedied without charge and within a reasonable time, you may wish to submit a complaint to the Administrator, National Highway Traffic Safety Administration, 1200 New Jersey Avenue, SE., Washington, DC 20590; or call the Vehicle Safety Hotline at (888) 327-4236 (TTY: 800-424-9153); or to <http://www.safercar.gov>. **For the Notice to Canadian Customers:** If you have questions about this Recall, please contact the Warranty Campaigns Department at (800) 547-0712, 7:00 a.m. to 4:00 p.m. Pacific Time, Monday through Friday, e-mail address DTNA.Warranty.Campaigns@Daimler.com, or the Customer Assistance Center at (800) 385-4357 after normal business hours.

We regret any inconvenience this action may cause but feel certain you understand our interest in motor vehicle safety.

WARRANTY CAMPAIGNS DEPARTMENT

Enclosure

January 2019
FL782A-S
NHTSA #18V-503
Transport Canada #18-395

Reimbursement to Customers for Repairs Performed Prior to Recall

If you have already **paid** to have this recall condition corrected you may be eligible to receive reimbursement.

Requests for reimbursement may include parts and labor. Reimbursement may be limited to the amount the repair would have cost if completed by an authorized Daimler Trucks North America LLC dealer. The following documentation must be presented to your dealer for consideration for reimbursement.

Please provide original or clear copies of all receipts, invoices, and repair orders that show:

- The name and address of the person who paid for the repair
- The Vehicle Identification Number (VIN) of the vehicle that was repaired
- What problem occurred, what repair was done, when the repair was done
- Who repaired the vehicle
- The total cost of the repair expense that is being claimed
- Proof of payment for the repair (such as the front and back of a cancelled check or a credit card receipt)

Reimbursement will be made by check from your Daimler Trucks North America LLC dealer.

Please speak with your Daimler Trucks North America LLC authorized dealer concerning this matter.

January 2019
FL782A-S
NHTSA #18V-503
Transport Canada #18-395

Work Instructions

Subject: Detroit Steer Axle Tie Rods

Models Affected: Specific Freightliner 114SD, Business Class M2, Cascadia, and Coronado vehicles, and Western Star 4900 vehicles manufactured July 1, 2011, through January 30, 2014.

Spider Plate and Tie Rod Replacement

1. Check the base label (Form WAR259) for a completion sticker for FL782 (Form WAR260) indicating this work has been completed. The base label is usually located on the passenger-side door, about 12 inches (30 cm) below the door latch. If a completion sticker is present, no work is needed. If a completion sticker is not present, proceed to the next step.
2. Park the vehicle on a level surface, shut down the engine, and set the parking brake. Chock the tires on the rear axle.
3. Raise the front axle and place safety stands under the frame or axle. Be sure the stands will support the weight of the vehicle.
4. Remove the front wheels. Refer to the applicable vehicle workshop manual:
 - *M2 Business Class Workshop Manual, Section 40.00, Subject 100.*
 - *122SD and Coronado Workshop Manual, Section 40.00, Subject 100.*
 - *108SD and 114SD Workshop Manual, Section 40.00, Subject 100.*
 - *Western Star Workshop Manual, the applicable subject in Section 40.00.*
 - *Cascadia Workshop Manual, Section 40.00, Subject 100.*
5. Remove the front hubs. Refer to **Section 33.01, Subject 100** in the applicable vehicle workshop manual.
6. Remove the brake assembly. Refer to the applicable section in **Group 42** of the vehicle workshop manual.
7. Disconnect the tie rod from the tie rod arms; see [Fig. 1](#). Remove the tie rod from the vehicle and discard it.

January 2019
FL782A-S
NHTSA #18V-503
Transport Canada #18-395

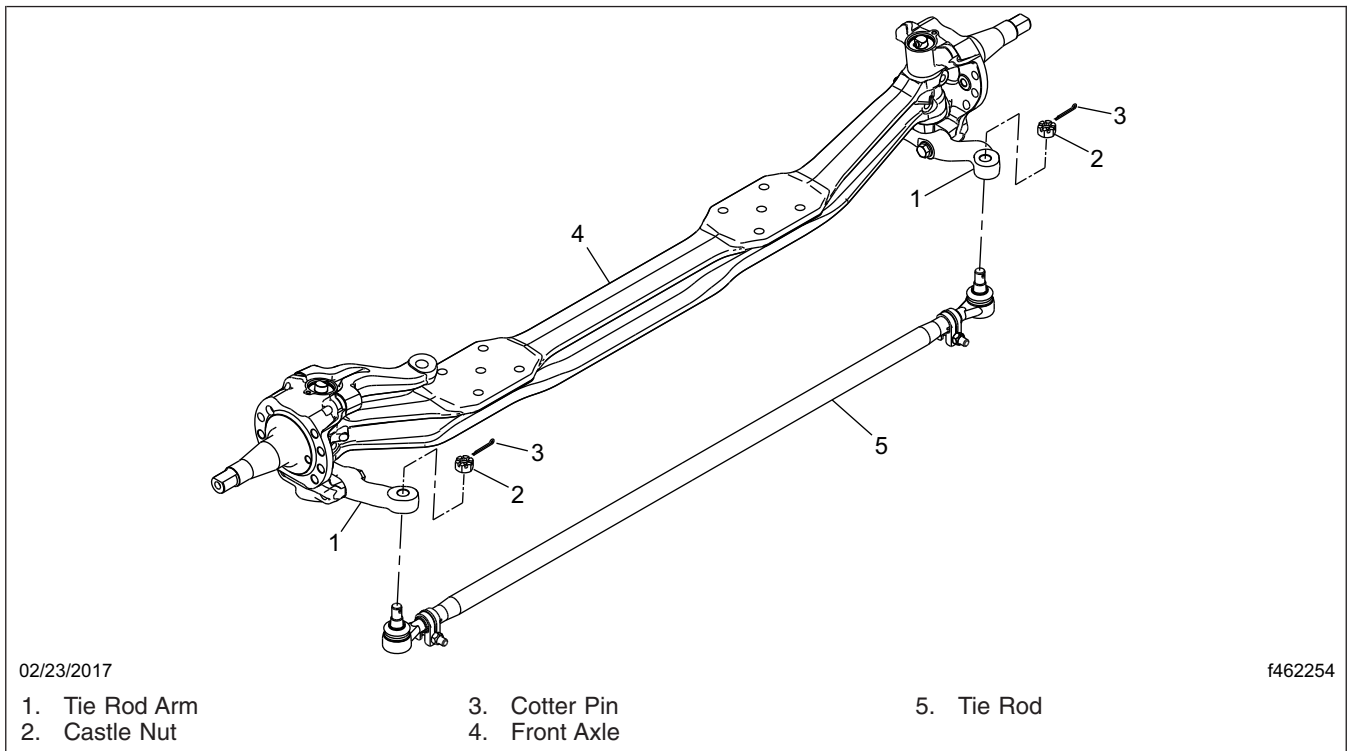

Fig. 1, Tie Rod Assembly

8. Attach a new tie rod to the tie rod arms. Tighten the castle nut 120 to 170 lbf-ft (163 to 230 N·m) plus a maximum of one-sixth of a turn to align a slot in the castle nut with the cotter pin hole in the tie rod stud. Insert the cotter pin and bend the tangs to secure it.
9. Clean and inspect all brake parts that will be reused. Refer to the applicable section in **Group 42** of the vehicle workshop manual.

NOTE: The spider plates, brake shoes, and dust shield (if equipped) will be replaced.

10. Install the brake components using the new spider plates, brake shoes, and dust shield (if equipped). Refer to the applicable section in **Group 42** of the vehicle workshop manual.
11. Install the front hubs. Refer to **Section 33.01, Subject 100** in the applicable vehicle workshop manual.
12. Install the front wheels. Refer to the applicable vehicle workshop manual:
 - *M2 Business Class Workshop Manual, Section 40.00, Subject 100.*
 - *122SD and Coronado Workshop Manual, Section 40.00, Subject 100.*
 - *108SD and 114SD Workshop Manual, Section 40.00, Subject 100.*
 - *Western Star Workshop Manual, the applicable subject in Section 40.00.*
 - *Cascadia Workshop Manual, Section 40.00, Subject 100.*
13. Remove the safety stands and lower the vehicle.
14. Align the front axle of the vehicle. See the vehicle *Workshop Manual, Group 33*.
15. Clean a spot on the base label (Form WAR259), write the recall number, FL782, on a red completion sticker (Form WAR260), and attach it to the base label to show this work has been completed.