

September 2018  
INT FL782-01  
NHTSA #18V-503  
Transport Canada #18-395  
**INTERIM RECALL BULLETIN**

**Subject: Detroit Steer Axle Tie Rods**

**Models Affected: Specific Freightliner 114SD, Business Class M2, Cascadia, and Coronado vehicles, and Western Star 4900 vehicles manufactured July 1, 2011, through January 30, 2014.**

**General Information**

Daimler Trucks North America LLC (DTNA), on behalf of its Freightliner Trucks Division, and its wholly owned subsidiary, Western Star Truck Sales, Inc., has decided that a defect that relates to motor vehicle safety exists on the vehicles mentioned above. Until the final Recall remedy is available, this interim procedure may be performed.

Certain vehicles manufactured with Detroit front axles and Meritor brakes may generate transient brake chatter which could lead to a fatigue failure of the tie-rod. Failure of the tie-rod could lead to a loss of vehicle control, which could increase the risk of a crash.

In the interim, the tie-rod will be replaced. Please note, all vehicles will still require the final remedy.

**Work Instructions**

Please refer to the attached work instructions.

**Replacement Parts**

Obtain parts for this interim Recall repair by ordering from your facing Parts Distribution Center.

**Table 1** - Interim Repair Parts for INT FL782

Campaign Number	Part Description	Part Number	Qty.
INT FL782-01 (Choose appropriate part for vehicle)	TIE ROD ASM	MBA 6803303703	1 ea
	TIE ROD ASM	MBA 6803304303	1 ea
	TIE ROD ASM	MBA 6803304403	1 ea
INT FL782-01	PIN-COTTER,1 3/4 X 1/8	23-00800-407	2 ea

**Table 1**

**Removed Parts**

Please follow Warranty Failed Parts Tracking shipping instructions for the disposition of all removed parts.

**Labor Allowance**

**Table 2** - Labor Allowance

Campaign Number	Procedure	Time Allowed (hours)	SRT Code	Corrective Action
INT FL782-01	Replace tie rod	1.7	996-R049B	12-Repair Recall/Campaign

**Table 2**

September 2018  
INT FL782-01  
NHTSA #18V-503  
Transport Canada #18-395  
**INTERIM RECALL BULLETIN**

## Claims for Credit

You will be reimbursed for your parts, labor, and handling by submitting your claim through the Warranty system within 30 days of completing an interim Recall repair. Please reference the following information in OWL:

NOTE: This is an interim repair procedure, during which the tie rod will be replaced. The full repair procedure will be released with the final recall. All vehicles will require the final remedy.

NOTE: Completion stickers will NOT be applied for the Interim repair; this step will occur in the final recall.

- Claim type is **Recall Campaign**.
- In the Campaign field, enter the campaign number and appropriate group (**INT FL782-01**).
- In the Primary Failed Part field, enter **25-FL782-000**.
- In the Parts section, enter the appropriate kit and/or part number(s) as shown in the Replacement Parts Table.
- In the Labor section, enter the appropriate SRT from the Labor Allowance Table. Administrative time will be included automatically as SRT 939-6010A for 0.3 hours.
- The VMRS Component Code is **015-004-045** and the Cause Code is **A1 - Campaign**.

Contact the Warranty Campaigns Department from 7:00 a.m. to 4:00 p.m. Pacific Time, Monday through Friday, via Web inquiry at [DTNACONNECT.com](http://DTNACONNECT.com) / WSC, or the Customer Assistance Center at (800) 385-4357, after normal business hours, if you have any questions or need additional information.

The interim letter notifying vehicle owners is included for your reference.

September 2018  
INT FL782-01  
NHTSA #18V-503  
Transport Canada #18-395  
**INTERIM RECALL BULLETIN**

## Copy of Notice to Owners

### Subject: Detroit Steer Axle Tie Rods

**For the Notice to U.S. Customers:** This notice is sent to you in accordance with the National Traffic and Motor Vehicle Safety Act.

**For the Notice to Canadian Customers:** This notice is sent to you in accordance with the Canadian Motor Vehicle Safety Act.

Daimler Trucks North America LLC (DTNA), on behalf of its Freightliner Trucks Division and wholly owned subsidiary, Western Star Truck Sales, Inc., has decided that a defect which relates to motor vehicle safety exists on specific Freightliner 114SD, Business Class M2, Cascadia, and Coronado vehicles, and Western Star 4900 vehicles manufactured July 1, 2011, through January 30, 2014

Certain vehicles manufactured with Detroit front axles and Meritor brakes may generate transient brake chatter which could lead to a fatigue failure of the tie-rod. Failure of the tie-rod could lead to a loss of vehicle control, which could increase the risk of a crash.

This is the first of two notices you will receive regarding this subject. This letter is to inform you of an upcoming Recall to correct the issue noted above. DTNA is currently validating the repair and securing replacement parts. In the interim, you may take your vehicle to an authorized Daimler Trucks North America dealer for a tie rod replacement (**your vehicle still requires the final Recall remedy**). To locate an authorized dealer, search online at [www.Daimler-TrucksNorthAmerica.com](http://www.Daimler-TrucksNorthAmerica.com) / Contact Us / Find a Dealer.

The second notice will inform you when the final remedy is available. When you receive the second notice, please contact an authorized DTNA dealer to schedule the final Recall remedy for your vehicle.

If you do not own the vehicle that corresponds to the identification number(s), which appears on the Recall Notice, please return the notification to the Warranty Campaigns Department with any information you can furnish that will assist us in locating the present owner. If you have leased this vehicle, Federal law requires that you forward this notice to the lessee within 10 days. If you are a subsequent stage manufacturer, Federal law requires that you forward this notice to your distributors and retail outlets within five working days.

**For the Notice to U.S. Customers:** If you have questions about this Recall, please contact the Warranty Campaigns Department at (800) 547-0712, 7:00 a.m. to 4:00 p.m. Pacific Time Monday through Friday, e-mail address [DTNA.Warranty.Campaigns@Daimler.com](mailto:DTNA.Warranty.Campaigns@Daimler.com), or the Customer Assistance Center at (800) 385-4357 after normal business hours. If you are not able to have the defect remedied without charge and within a reasonable time, you may wish to submit a complaint to the Administrator, National Highway Traffic Safety Administration, 1200 New Jersey Avenue, SE., Washington, DC 20590; or call the Vehicle Safety Hotline at (888) 327-4236 (TTY: 800-424-9153); or to <http://www.safercar.gov>.

**For the Notice to Canadian Customers:** If you have questions about this Recall, please contact the Warranty Campaigns Department at (800) 547-0712, 7:00 a.m. to 4:00 p.m. Pacific Time Monday through Friday, e-mail address [DTNA.Warranty.Campaigns@Daimler.com](mailto:DTNA.Warranty.Campaigns@Daimler.com), or the Customer Assistance Center at (800) 385-4357 after normal business hours.

We regret any inconvenience this action may cause but feel certain you understand our interest in motor vehicle safety.

WARRANTY CAMPAIGNS DEPARTMENT

Enclosure

September 2018  
INT FL782-01  
NHTSA #18V-503  
Transport Canada #18-395  
**INTERIM RECALL BULLETIN**

## Work Instructions

### Subject: Detroit Steer Axle Tie Rods

**Models Affected:** Specific Freightliner 114SD, Business Class M2, Cascadia, and Coronado vehicles, and Western Star 4900 vehicles manufactured July 1, 2011, through January 30, 2014.

### Tie Rod Replacement

NOTE: This is an interim repair procedure, during which the tie rod will be replaced. The full repair procedure will be released with the final recall. All vehicles will require the final remedy.

NOTE: Completion stickers will NOT be applied for the Interim repair; this step will occur in the final recall.

1. Park the vehicle on a level surface, shut down the engine, and set the parking brake. Chock the tires on the rear axle.
2. Raise the front axle and place safety stands under the frame or axle. Be sure the stands will support the weight of the vehicle.
3. Disconnect the tie rod from the tie rod arms; see [Fig. 1](#). Remove the tie rod from the vehicle and discard it.

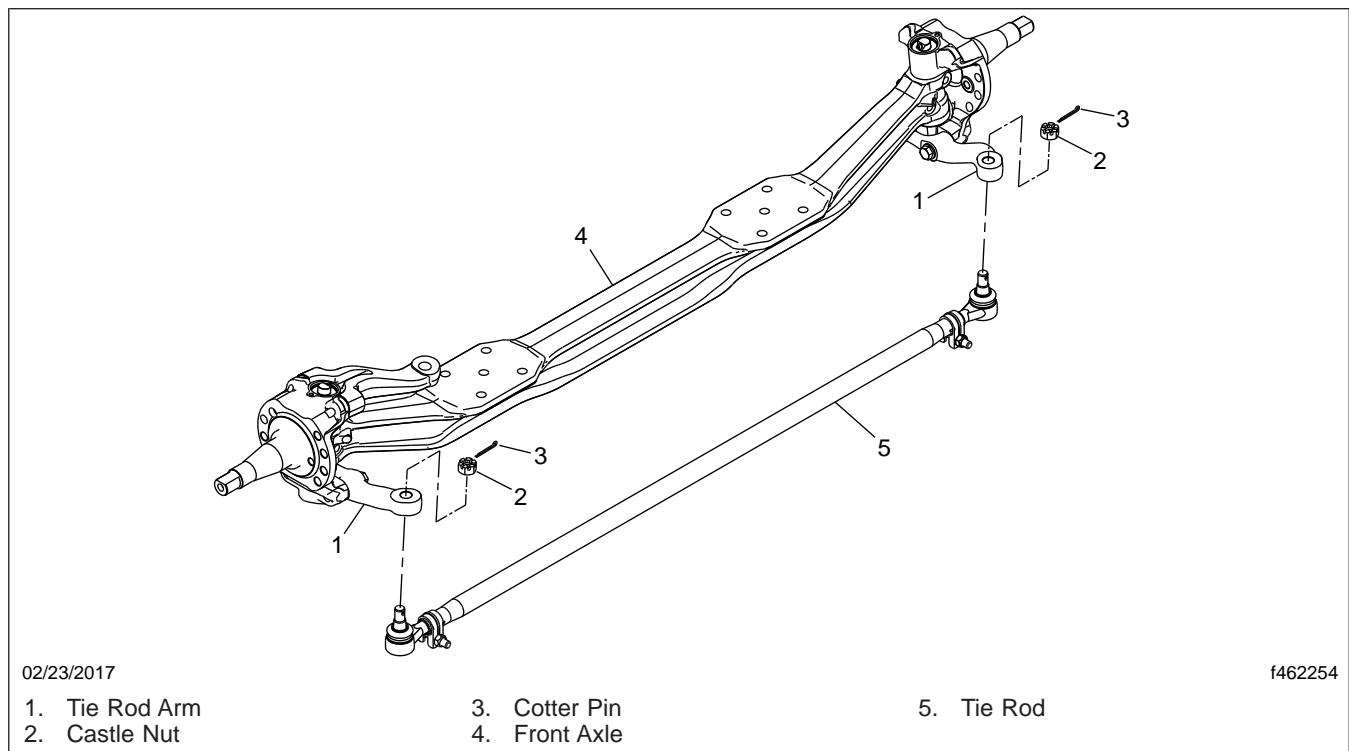

**Fig. 1, Tie Rod Assembly**

4. Attach a new tie rod to the tie rod arms. Tighten the castle nut 120 to 170 lbf-ft (163 to 230 N·m) plus a maximum of one-sixth of a turn to align a slot in the castle nut with the cotter pin hole in the tie rod stud. Insert the cotter pin and bend the tangs to secure it.

September 2018  
INT FL782-01  
NHTSA #18V-503  
Transport Canada #18-395  
**INTERIM RECALL BULLETIN**

5. Remove the safety stands and lower the vehicle.
6. Align the front axle of the vehicle. See the vehicle *Workshop Manual*, **Group 33**.
7. When the repair is complete, **DO NOT** install a completion sticker. This step will take place when the final remedy is performed.