

Keystone RV Company

8/3/18

SAFETY ADVISORY # 18-326

Aerolite Safety Chains

Keystone is conducting a voluntary RECALL notification campaign in accordance with the National Highway Transportation and Safety Act. It has been decided that the vehicles in the recall population were built with safety chains that are underrated for the Gross Vehicle Weight Rating (GVWR). If the vehicle becomes detached from the tow vehicle, the safety chains may not carry the weight of the unit as designed, leading to an increased risk of property damage and or vehicle crash.

Models Included: 2018 – 2019 Aerolite Travel Trailers: 2843BH

Serial Number Ranges: 2018 JP910566 - JP911096
2019 KP910034 - KP910364

Parts Required: 1 – KRV # 243950- Chain - Elbow - .5 x 6 - For Front A Frame
2 – KRV # 243951- Chain - Safety - 11700# - For Front A Frame

Tools Required: - grinder - welder - die grinder with cut off wheel

Note – Check serial number on Key Express to verify the campaign is open. Some vehicles were repaired before they left Keystone.

When performing warranty or recall service, please make certain that appropriate Personal Protective Equipment (PPE) is used.

The remedy is to remove the incorrect safety chains (7,600 pounds) and install the correct safety chains (11,700 pounds).

REPAIR INSTRUCTIONS

Step 1

Locate the trailer on a level, flat, hard surface. Chock the wheels and disconnect 12VDC and 120VAC power to unit.

Step 2

Follow the attached Lippert instructions for replacing safety chains.



LIPPERT
COMPONENTS®

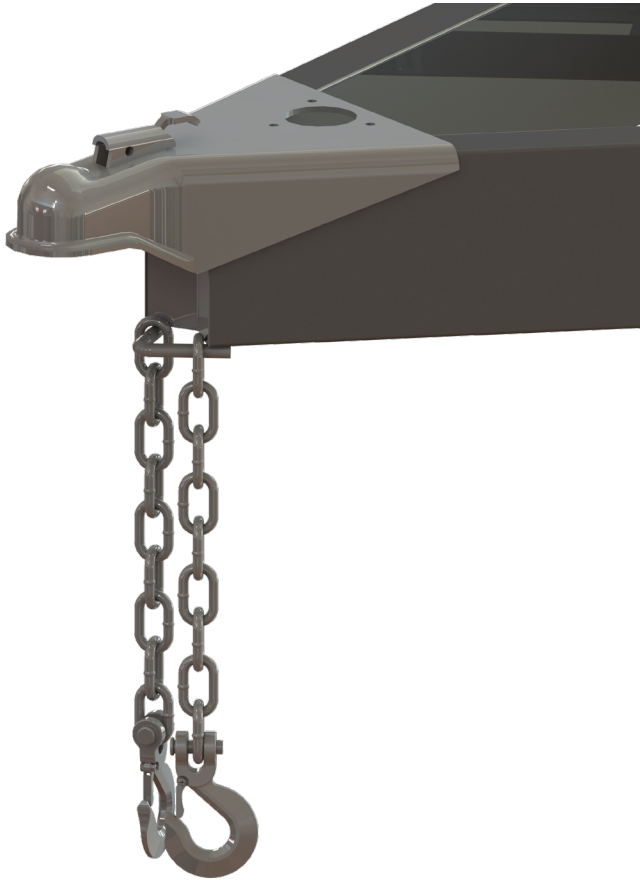

Travel Trailer Safety Chain

Installation and Owner's Manual

(For Aftermarket Applications)

Table of Contents

Introduction	2
Safety	2
Preparation	2
Resources Required	2
Parts List	2
Procedure	3



Travel Trailer Safety Chain

Installation and Owner's Manual

(For Aftermarket Applications)

Introduction

The following instructions outline the procedure to replace an existing travel trailer safety chain.

Additional information about this product can be obtained from lci1.com/support or by downloading the free myLCI app. The app is available on iTunes® for iPhone® and iPad® and also on Google Play™ for Android™ users.

iTunes®, iPhone®, and iPad® are registered trademarks of Apple Inc.

Safety

⚠ WARNING

REMOVE ALL FLAMMABLE MATERIALS FROM THE AREA TO BE WELDED. ANY REMAINING FLAMMABLE MATERIAL THAT CANNOT BE REMOVED MUST BE PROTECTED. PROPER FIRE PROTECTION AND CONTROL MEASURES SHOULD BE KEPT ON HAND.

⚠ WARNING

LIFT TRAILER BY THE FRAME AND NEVER THE AXLE OR SUSPENSION. DO NOT GO UNDER THE TRAILER UNLESS IT IS PROPERLY SUPPORTED BY JACK STANDS. UNSUPPORTED TRAILERS CAN FALL AND MAY RESULT IN DEATH, SERIOUS INJURY OR PROPERTY DAMAGE.

Preparation

This procedure should only be completed by an authorized service technician.

In this manual orange lines indicate using a die grinder to remove components, red lines indicate using a welder to add components per instructions and image references, and green lines indicate area to be ground smooth.

Resources Required

- Die grinder and cut wheel attachments
- Welder
- Welding PPE (helmet, gloves, sleeves, etc.)
- Jack stands
- Black spray paint (if necessary)

Parts List

Part numbers will vary depending on weight ratings required. All parts are sold individually.

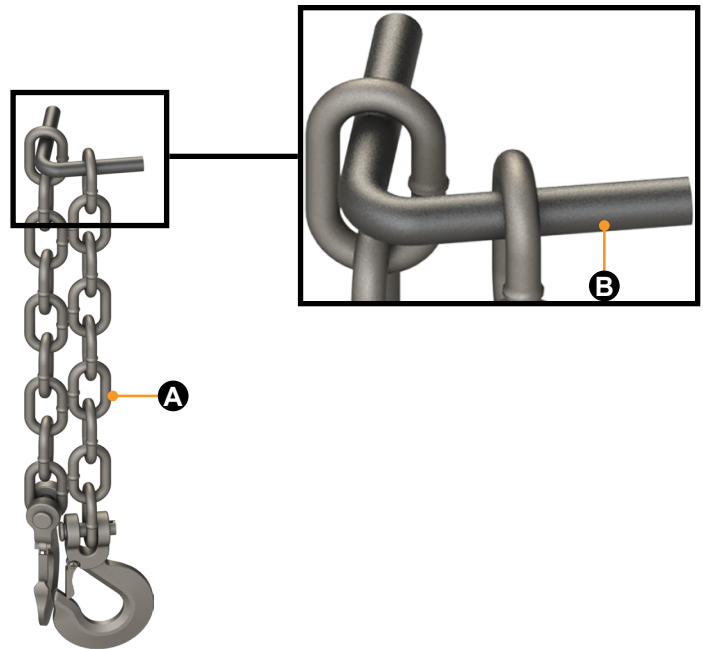

Letter	Part #	Description	Qty
A	133748	27" Safety Chain and Hook (16,200 lbs)	1
A	128657	27" Safety Chain and Hook (7,600 lbs)	1
B	119124	Safety Chain Elbow	1



Travel Trailer Safety Chain Installation and Owner's Manual (For Aftermarket Applications)

Procedure

Remove old chain as follows:

1. Use the die grinder with the cutting wheel attachment to remove the existing chain elbow from the underside of the A-frame coupler (Fig.1).
2. The existing safety chains can be set aside with the chain elbow.

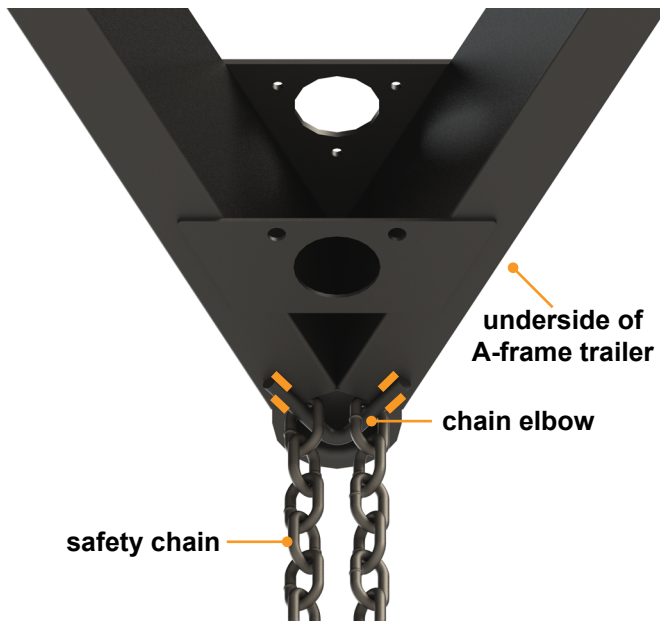

Fig.1

3. Use the die grinder and grinding wheel attachment to grind the cut areas smooth (Fig.2).

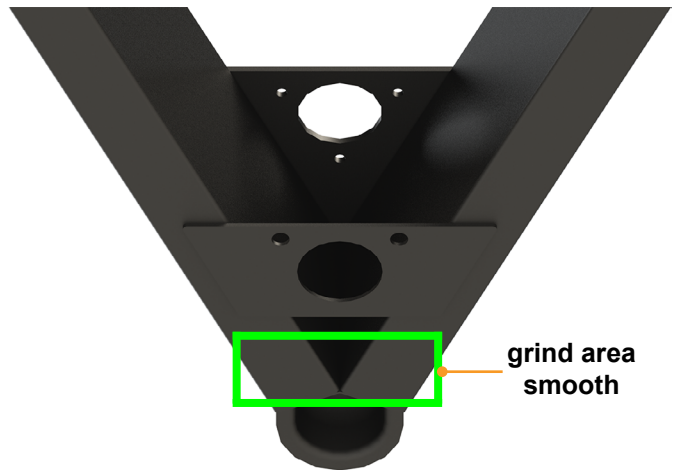

Fig.2

4. Feed the last link of each of the new safety chains onto the new chain elbow (Fig.3)

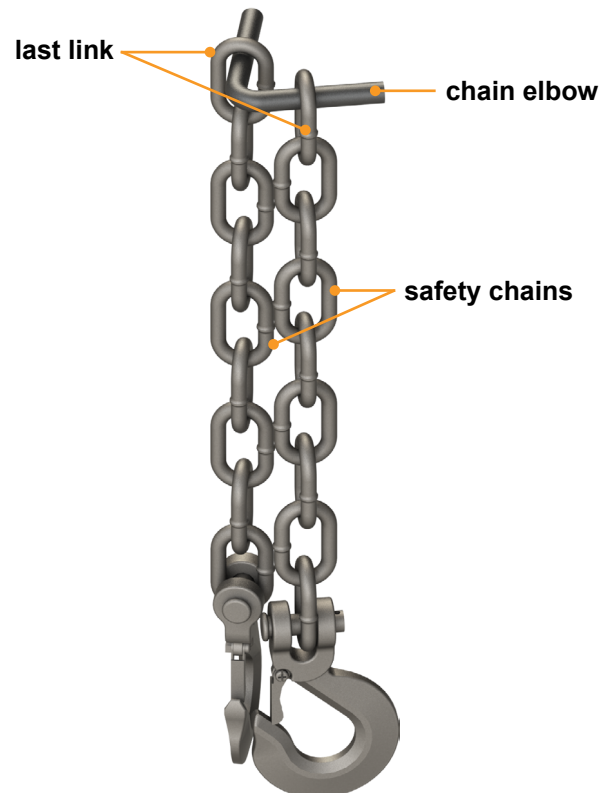

Fig.3



Travel Trailer Safety Chain

Installation and Owner's Manual

(For Aftermarket Applications)

5. Center the chain elbow and safety chain assembly under the A-frame coupler so that the ends of the chain elbow are touching the ends of the two A-frame tubes (Fig.4). The elbow should be pointing away from the trailer.

NOTE: Make sure that the new safety chains are not pinched between the chain elbow and the coupler. The safety chains **MUST** be able to move freely.

NOTE: The outside point of the elbow bend **MUST** measure 1 3/8" maximum to 1 1/8" minimum from the A-frame (Fig.4).

6. Stitch weld each end of the chain elbow to the A-frame tubes (Figs.4 and 5). Make certain to weld both the inside and outside of the chain elbow (Fig.5 and 6).

7. Test the movement ability of the safety chains to make sure they are able to move freely (Fig.5).

8. Spray paint any visible areas of the repair with black spray paint.

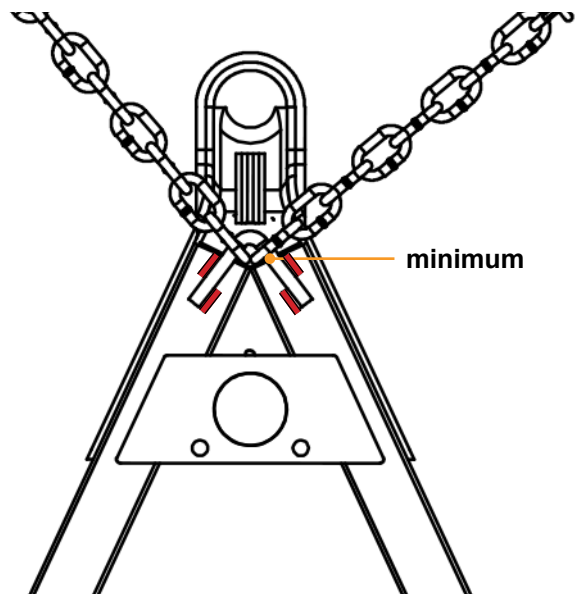
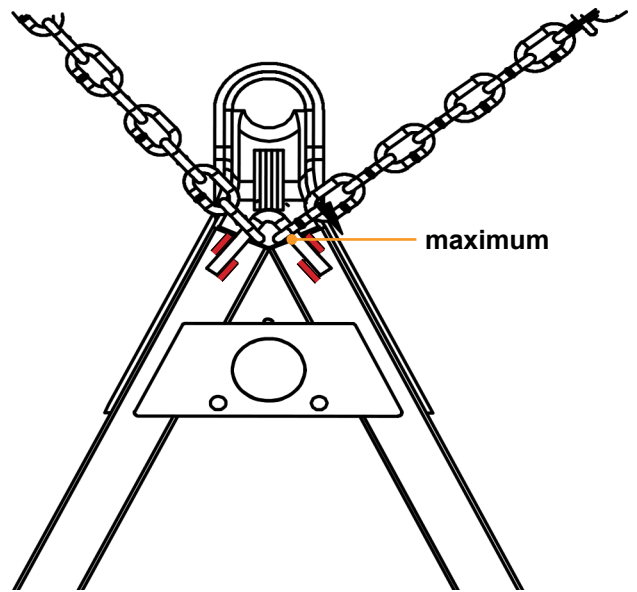

Fig.5

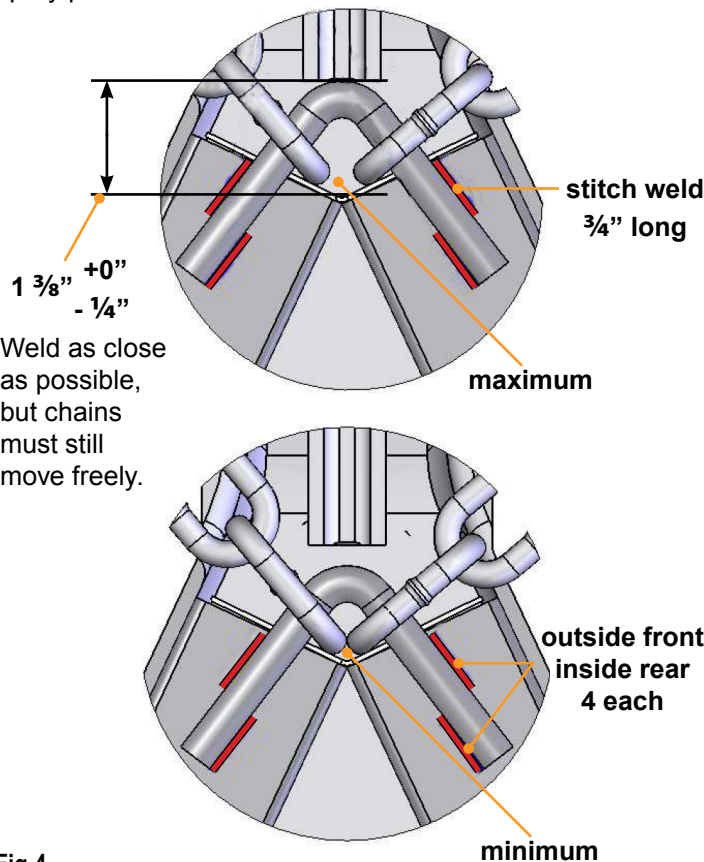

Fig.4



LIPPERT
COMPONENTS®

Travel Trailer Safety Chain

Installation and Owner's Manual
(For Aftermarket Applications)

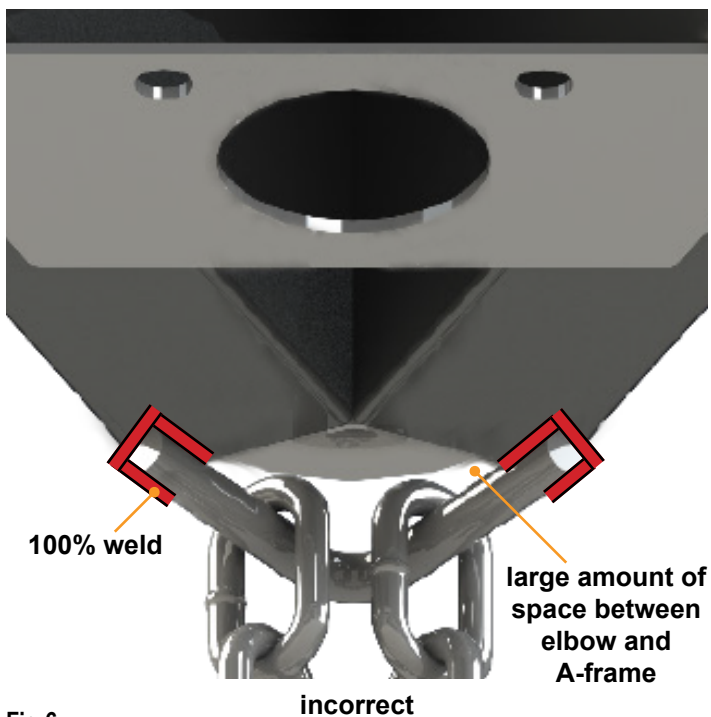
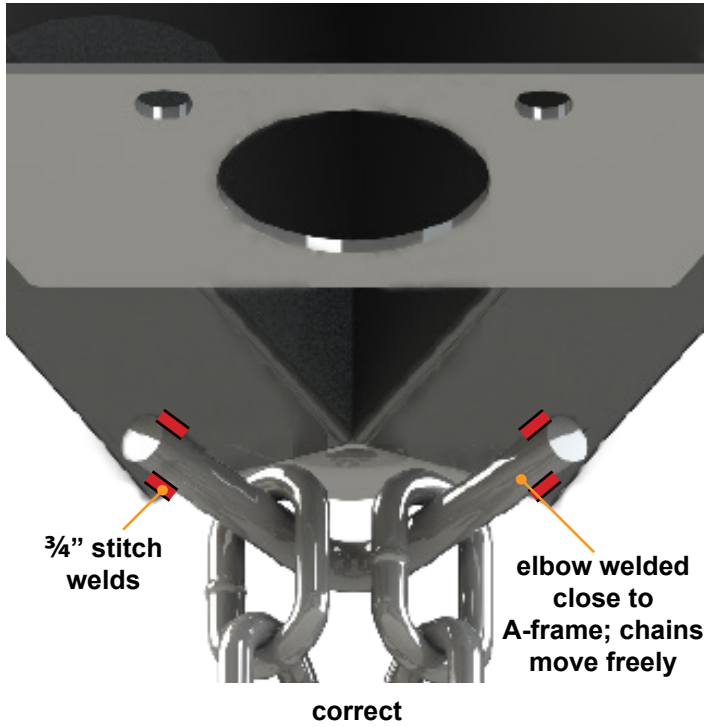

Fig.6

Step 3

Proceed to warranty reimbursement.

WARRANTY REIMBURSEMENT

REPAIR

Submit the claim on Key Express using **Flat Rate Code # 7132642B**

In the Complaint section note: Safety Advisory # 18-326

In the Cause section note: Incorrect chains installed

In the Correction section note: Replaced incorrect safety chains with proper size

The amount of time authorized for this repair is **0.7 hour**.

PARTS DISPOSITION

No part return.

Please call Keystone RV Customer Service at **(855)382-4100** if you have any questions.