

Safety Recall

Code: 69R7



Audi

REVISION

| | |
|-------------------------------|--|
| Subject | Passenger Frontal Airbag (Takata) |
| Revision Summary | Updated instructions for the mandatory Takata parts return process in Appendix B. |
| Release Date | July 21, 2018 |
| Affected Vehicles | U.S.A. & Canada: Certain 2005-2011 MY Audi vehicles <i>Check Campaigns/Actions screen in Elsa on the day of repair to verify that a VIN qualifies for repair under this action. Elsa is the <u>only</u> valid campaign inquiry & verification source.</i> <ul style="list-style-type: none">✓ Campaign status must show "open."✓ If Elsa shows other open action(s), inform your customer so that the work can also be completed at the same time the vehicle is in the workshop for this campaign. |
| Problem Description | The passenger frontal airbag may explode in a crash with airbag deployment. Sharp metal fragments can hit people and cause serious injury or death. |
| Corrective Action | Replace the passenger frontal airbag with a newly manufactured version. This is considered to be the final repair for these vehicles. |
| Precautions | Audi recommends avoiding use of the front passenger seat whenever possible until the recall repair has been performed. |
| Code Visibility | On or about June 29, 2018 affected vehicles were listed on the Inventory Vehicle Open Campaign Action report under My Dealership Reports (found on www.accessaudi.com & OMD Web). A list was not posted for dealers who did not have any affected vehicles. On or about June 29, 2018 this campaign code showed open on affected vehicles in Elsa. On or about June 29, 2018 affected vehicles were identified with this campaign code in the VIN Lookup tool at www.audiusa.com and on the NHTSA VIN lookup tool at www.safercar.gov . |
| Owner Notification | Owner notification took place in June 2018. Owner letter examples are included in this bulletin for your reference. |
| Parts Department | Parts will be allocated weekly. Please email VWoAPartsSpecialists@vw.com with VIN if you do not have the proper part(s) in stock. |
| Additional Information | Please alert everyone in your dealership about this action, including Sales, Service, Parts and Accounting personnel. Contact Warranty if you have any questions. IMPORTANT REMINDER ON VEHICLES AFFECTED BY SAFETY & COMPLIANCE RECALLS <u>New Vehicles in Dealer Inventory:</u> It is a violation of Federal law for a dealer to deliver a new motor vehicle or any new or used item of motor vehicle equipment (including a tire) covered by this notification under a sale or lease until the defect or noncompliance is remedied. By law, dealers must correct, prior to delivery for sale or lease, any vehicle that fails to comply with an applicable Federal Motor Vehicle Safety Standard or that contains a defect relating to motor vehicle safety. <u>Pre-Owned Vehicles in Dealer Inventory:</u> Dealers should not deliver any pre-owned vehicles in their inventory which are involved in a safety or compliance recall until the defect has been remedied. Dealers must ensure that every affected inventory vehicle has this campaign completed <u>before</u> delivery to consumers. |

| Criteria I.D. | 8E and 01 (Audi A4) Enter ALL criteria on ONE claim 8H and 01 (Audi A4 Cabriolet) Enter ALL criteria on ONE claim | | | | | | | | | |
|----------------------|--|---------------------|-------------|-------------|------|------------|-------------------|------|------------|---------------------|
| | <p>VEHICLES WITHOUT CD CHANGER</p> <p>Inspect passenger airbag, no replacement necessary Labor operation: 6815 20 99 20 T.U.</p> <p>-OR-</p> <p>Inspect and replace passenger airbag Labor operation: 6959 56 99 40 T.U.</p> <table border="1"> <thead> <tr> <th>Quantity</th> <th>Part Number</th> <th>Description</th> </tr> </thead> <tbody> <tr> <td>1.00</td> <td>8E1880204F</td> <td>Passenger Airbag*</td> </tr> <tr> <td>4.00</td> <td>N 90887703</td> <td>M6 Self Locking Nut</td> </tr> </tbody> </table> | Quantity | Part Number | Description | 1.00 | 8E1880204F | Passenger Airbag* | 4.00 | N 90887703 | M6 Self Locking Nut |
| Quantity | Part Number | Description | | | | | | | | |
| 1.00 | 8E1880204F | Passenger Airbag* | | | | | | | | |
| 4.00 | N 90887703 | M6 Self Locking Nut | | | | | | | | |
| Criteria I.D. | 8E and 01 (Audi A4) Enter ALL criteria on ONE claim 8H and 01 (Audi A4 Cabriolet) Enter ALL criteria on ONE claim | | | | | | | | | |
| | <p>VEHICLES WITH CD CHANGER</p> <p>Inspect passenger airbag, no replacement necessary Labor operation: 6815 21 99 30 T.U.</p> <p>-OR-</p> <p>Inspect and replace passenger airbag Labor operation: 6959 57 99 50 T.U.</p> <table border="1"> <thead> <tr> <th>Quantity</th> <th>Part Number</th> <th>Description</th> </tr> </thead> <tbody> <tr> <td>1.00</td> <td>8E1880204F</td> <td>Passenger Airbag*</td> </tr> <tr> <td>4.00</td> <td>N 90887703</td> <td>M6 Self Locking Nut</td> </tr> </tbody> </table> | Quantity | Part Number | Description | 1.00 | 8E1880204F | Passenger Airbag* | 4.00 | N 90887703 | M6 Self Locking Nut |
| Quantity | Part Number | Description | | | | | | | | |
| 1.00 | 8E1880204F | Passenger Airbag* | | | | | | | | |
| 4.00 | N 90887703 | M6 Self Locking Nut | | | | | | | | |

The repair information in this document is intended for use only by skilled technicians who have the proper tools, equipment and training to correctly and safely maintain your vehicle. These procedures are not intended to be attempted by "do-it-yourselfers," and you should not assume this document applies to your vehicle, or that your vehicle has the condition described. To determine whether this information applies, contact an authorized Audi dealer. ©2018 Audi of America, Inc. and Audi Canada. All Rights Reserved.

Customer Letter Example (USA)

NHTSA: <INSERT NUMBER>

**Subject: Safety Recall 69R7 – Passenger Frontal Airbag (Takata)
Certain 2005-2011 Model Year Audi Vehicles**

Dear Audi Owner,

This notice is sent to you in accordance with the National Traffic and Motor Vehicle Safety Act. Audi has decided that a defect, which relates to motor vehicle safety, exists in certain 2005-2011 model year Audi vehicles. Our records show that you are the owner of a vehicle affected by this action.

DANGER!

The passenger frontal airbag may explode in a crash with airbag deployment.

Sharp metal fragments can hit people and cause serious injury or death.

What should you do? Please contact your authorized Audi dealer to schedule this **FREE** recall repair immediately, even if an interim repair was recently done.

For your convenience, you can also visit www.audiusa.com and click on the “Find a Dealer” link to locate a dealer near you and schedule this service.

What will we do? To correct this defect, your authorized Audi dealer will replace the passenger frontal airbag in your vehicle. This work will take about an hour to complete and will be performed for you for **FREE**.

Please keep in mind that your dealer may need additional time for the preparation of the repair, as well as to accommodate their daily workshop schedule.

Precautions you should take Audi recommends avoiding use of the front passenger seat whenever possible until the recall repair has been performed.

Lease vehicles and address changes If you are the lessor and registered owner of the vehicle identified in this action, the law requires you to forward this letter immediately via first-class mail to the lessee within ten (10) days of receipt. If you have changed your address or sold the vehicle, please fill out the enclosed prepaid Owner Reply card and mail it to us so we can update our records.

Can we assist you further? If you need help scheduling this repair, or if your authorized Audi dealer fails or is unable to complete this work free of charge within a reasonable time, please contact Audi Customer Experience at 1-800-253-2834 or via our “Contact Us” page at www.audiusa.com.

Checking your vehicle for open Recalls and Service Campaigns To check your vehicle’s eligibility for repair under this or any other recall/service campaign, please visit the **Recall/Service Campaign Lookup** tool at www.audiusa.com and enter your Vehicle Identification Number (VIN).

If you still cannot obtain satisfaction, you may file a complaint with: The Administrator, National Highway Traffic Safety Administration, 1200 New Jersey Avenue, SE., Washington, DC 20590; or call the toll-free Vehicle Safety Hotline at 1-888-327-4236 (TTY: 1-800-424-9153); or go to <http://www.safercar.gov>.

We apologize for any inconvenience this matter may cause; however we are taking this action to help ensure your safety and continued satisfaction with your vehicle.

Sincerely,

Audi Customer Protection

**Subject: Safety Recall 69R7 – Passenger Frontal Airbag (Takata)
Certain 2005-2011 Model Year Audi Vehicles**

Dear Audi Owner,

This notice is sent to you in accordance with the requirements of the Motor Vehicle Safety Act. Audi has decided that a defect, which relates to motor vehicle safety, exists in certain 2005-2011 model year Audi vehicles. Our records show that you are the owner of a vehicle affected by this action.

DANGER!

**The passenger frontal airbag may explode in a crash with airbag deployment.
Sharp metal fragments can hit people and cause serious injury or death.**

What should you do? Please contact your authorized Audi dealer to schedule this FREE recall repair immediately, even if an interim repair was recently done.

What will we do? To correct this defect, your authorized Audi dealer will replace the passenger frontal airbag in your vehicle. This work will take about an hour to complete and will be performed for you for FREE.

Please keep in mind that your dealer may need additional time for the preparation of the repair, as well as to accommodate their daily workshop schedule.

Precautions you should take Audi recommends avoiding use of the front passenger seat whenever possible until the recall repair has been performed.

Lease vehicles and address changes If you are the lessor and registered owner of the vehicle identified in this action, the law requires you to forward this letter immediately via first-class mail to the lessee within ten (10) days of receipt. If you have changed your address or sold the vehicle, please fill out the enclosed prepaid Owner Reply card and mail it to us so we can update our records.

Can we assist you further? If your authorized Audi dealer fails or is unable to complete this work free of charge within a reasonable time, please contact Audi Customer Relations Monday through Friday from 8AM to 8PM EST at 1-800-822-2834 or via our "Contact Audi Canada" page at www.audi.ca.

We apologize for any inconvenience this matter may cause; however we are taking this action to help ensure your safety and continued satisfaction with your vehicle.

Sincerely,

Audi Customer Protection

 DANGER

- The driver frontal airbag inflator could potentially rupture (due to propellant degradation occurring after long-term exposure to absolute high humidity and temperature cycling). In the event of an inflator rupture, in very rare cases metal fragments could pass through the airbag cushion material, which may result in serious injury or death.
- All Takata Recalls should be performed before any other work is performed on the vehicle.

 WARNING

Risk of injury. Refer to “Warning and Safety Precautions”, found in **Appendix A** at the end of this document.

 NOTE

- Damages resulting from improper repair or failure to follow these work instructions are the dealer’s responsibility and are not eligible for reimbursement under this action.
- This procedure must be read in its entirety prior to performing the repair.
- Due to variations in vehicle equipment and options, the steps/illustrations in this work procedure may not identically match all affected vehicles.
- Diagnosis and repair of pre-existing conditions in the vehicle are not covered under this action.

Required Parts

| <u>Criteria</u> | <u>Model</u> | <u>Quantity</u> | <u>Part Number</u> | <u>Part Description</u> |
|-----------------|------------------|-----------------|--------------------|--|
| 4F | A6 | 1 | 4F1880204F | Passenger Airbag |
| | | 4 | N 02300213 | M6 Self Locking Nut |
| | | 4 | N 90654602 | M6 x 18.25 Bolt (airbag bracket to central tube) |
| | | 4 | N 10305302 | M6 x 20 Bolt (airbag bracket to airbag) |
| 8E, 8H | A4, A4 Cabriolet | 1 | 8E1880204F | Passenger Airbag |
| | | 4 | N 90887703 | M6 Self Locking Nut |

The repair information in this document is intended for use only by skilled technicians who have the proper tools, equipment and training to correctly and safely maintain your vehicle. These procedures are not intended to be attempted by “do-it-yourselfers,” and you should not assume this document applies to your vehicle, or that your vehicle has the condition described. To determine whether this information applies, contact an authorized Audi dealer. ©2018 Audi of America, Inc. and Audi Canada. All Rights Reserved.

Required Tools

| | | | |
|--|---|--|---|
|  | <p>Diagnostic Tester -VAS6150X- (or equivalent)</p> |  | <p>Torque Wrench (4 - 20 Nm) -1410- (or equivalent)</p> |
|  | <p>Bar Code Scanner -VAS6161/1- (or equivalent)</p> |  | <p>Radio Removal Tool -T10057-</p> |
|  | <p>Fiber-Optic Repair Set - Connector Protective Caps -VAS6223/9-</p> | | |

Repair Instruction

Section A - Check for Previous Repair

| Applicable criteria ID(s) | Campaign/Action Status |
|---------------------------|------------------------|
| 01 ← 2 | Open ← 1 |

EXAMPLE

- Enter the VIN in Elsa and proceed to the “Campaign/Action” screen.

TIP

On the date of repair, print this screen and keep a copy with the repair order.

- Confirm the Campaign/Action is open <arrow 1>. If the status is closed, no further work is required.
- Note the Applicable Criteria ID <arrow 2> for use in determining the correct work to be done and corresponding parts associated.

Proceed to Section B

Section B – Passenger Airbag Inspection

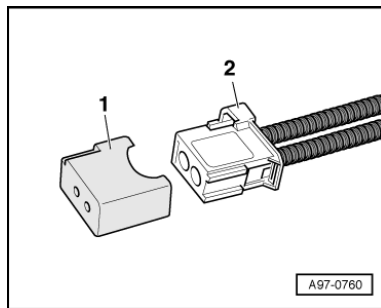
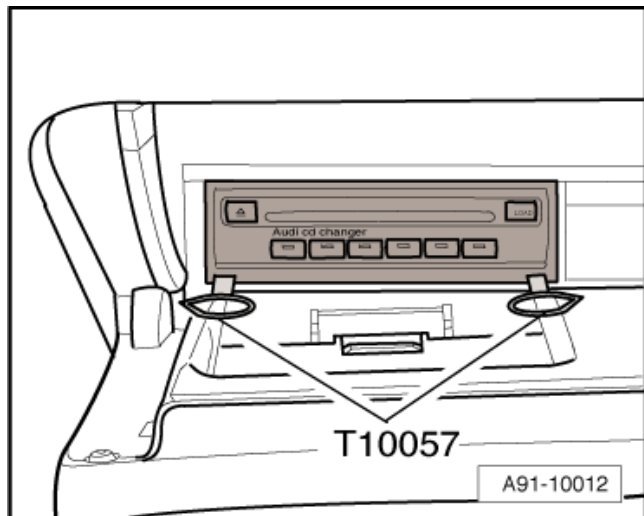

- If applicable, remove CD Changer -R41- as follows:
 - Insert 2 clamps on Radio Removal Tool -T10057- in front side of CD Changer -R41-.
 - Top L = upper left.
 - Top R = upper right.
 - Remove CD Changer -R41- from installation frame.
 - Disconnect electrical connector.
 - Disconnect fiber optic connector <2>.
 - Seal the open wiring set connector <2> for fiber-optic cable using Protective Cap for Cable Connector -VAS 6223/9- <item 1>.
 - Remove release tools by pressing locking tabs on CD Changer -R41-.

! NOTE

The protective cap prevents soiling and damage to fiber optic face, which would impair light transfer.

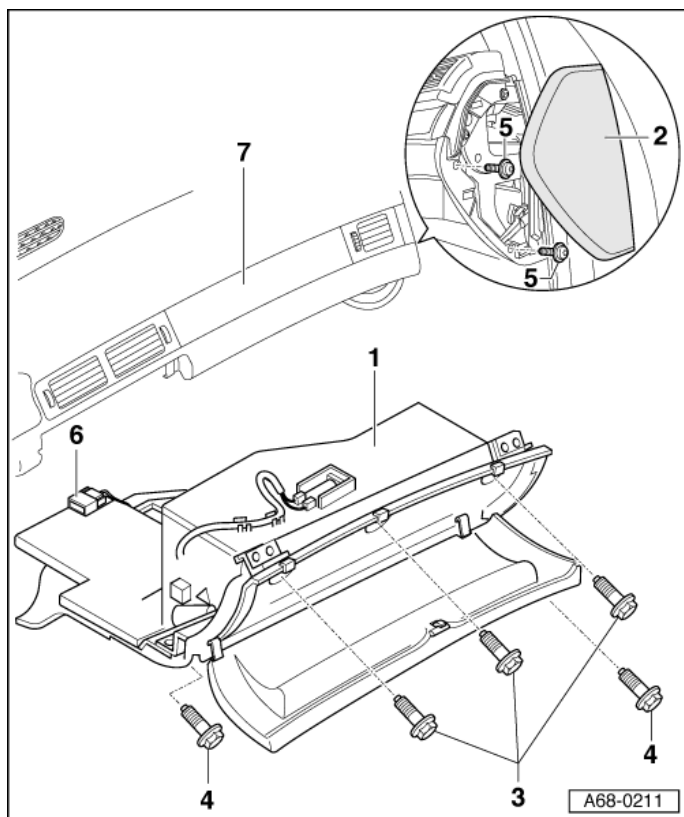

- Disconnect instrument panel cover <2>.
- Open glove compartment cover.
- Remove three bolts <3> at top in depressions of glove compartment <1>.
- Remove outside bolts <5>.
- Remove bolts <4>.
- Remove glove compartment downward.
- Remove connector <6> from glove compartment light.

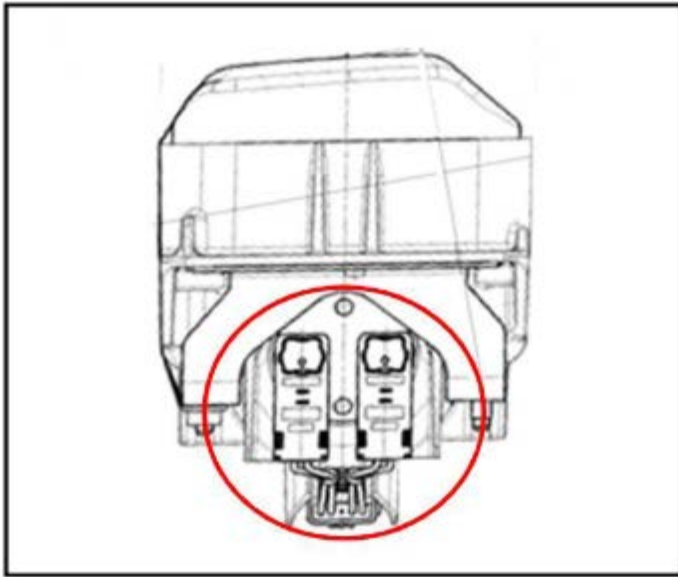

- If the passenger airbag inflator connectors are configured side by side <as shown>, the airbag was not manufactured by Takata and NO further work is required:
 - Reassemble glove box and **Continue to Section E.**



- If the passenger airbag inflator connectors are configured on the ends <as shown>, the airbag was manufactured by Takata and will require replacement.

Continue to Section C.

Section C – Passenger Airbag Identification (all vehicles)

⚠ WARNING

Risk of injury.

- People in the immediate vicinity of the workplace must be protected from possible noise and projectiles.
- Pyrotechnic components can trigger unintentionally.
- In the event of unintentional deployment:
 - Single-stage generators: allow airbag to cool down completely. Wait at least 10 minutes before handling.
 - Two-stage generators: wait for second airbag ignition. Allow airbag to cool down completely. Wait at least 10 minutes before handling.



- Ensure ODIS is updated to the latest version.
- Connect vehicle diagnostic tester to the vehicle using USB cable.
- Select Start Diagnosis function and identify vehicle.
- After identification of control units, Guided Fault Finding is started automatically.
- Follow the instructions on screen.

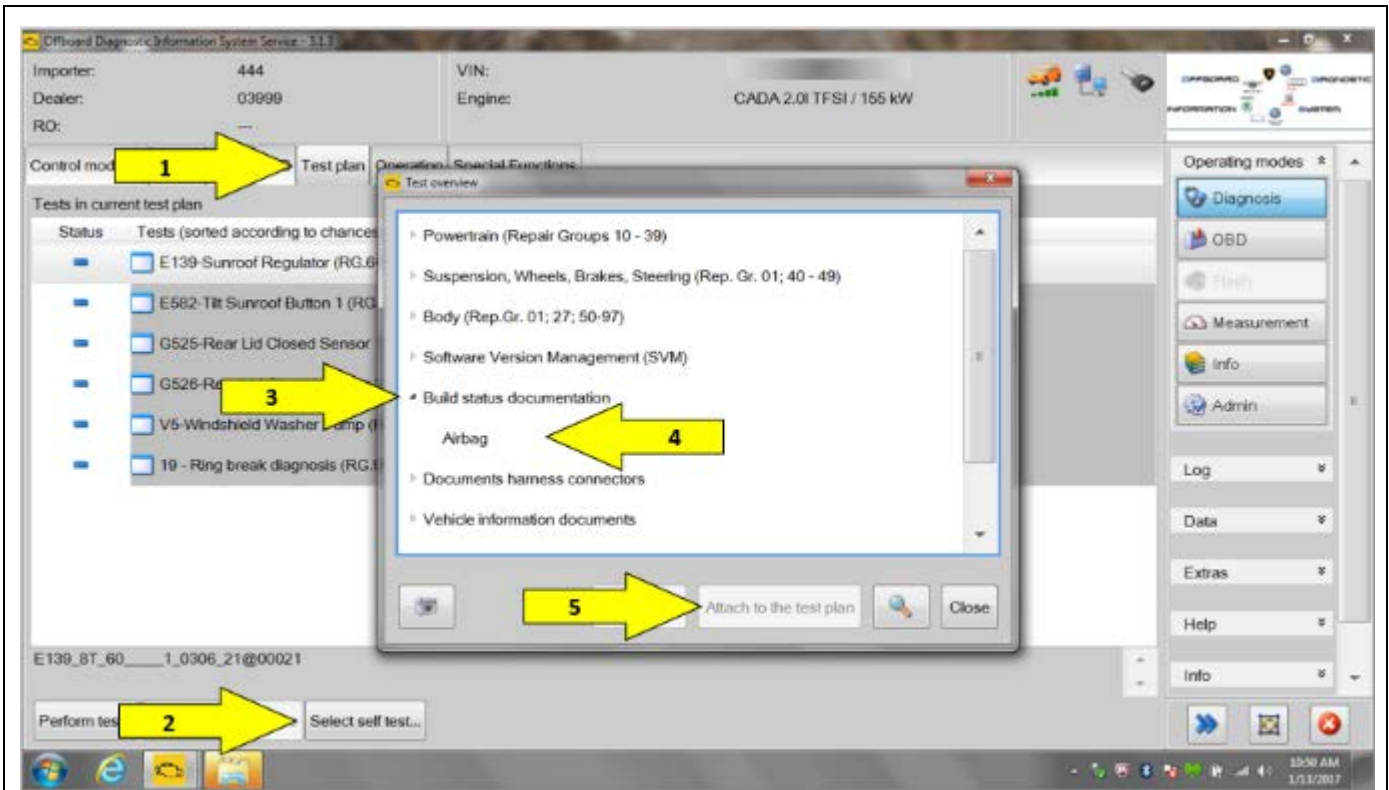

- Select the “Test plan” tab <1>.
- Select “Select self test...” <2>.
- Open the “Build status documentation” dropdown <3>.
- Highlight “Airbag” <4>.
- Select “Attach to the test plan <5>.

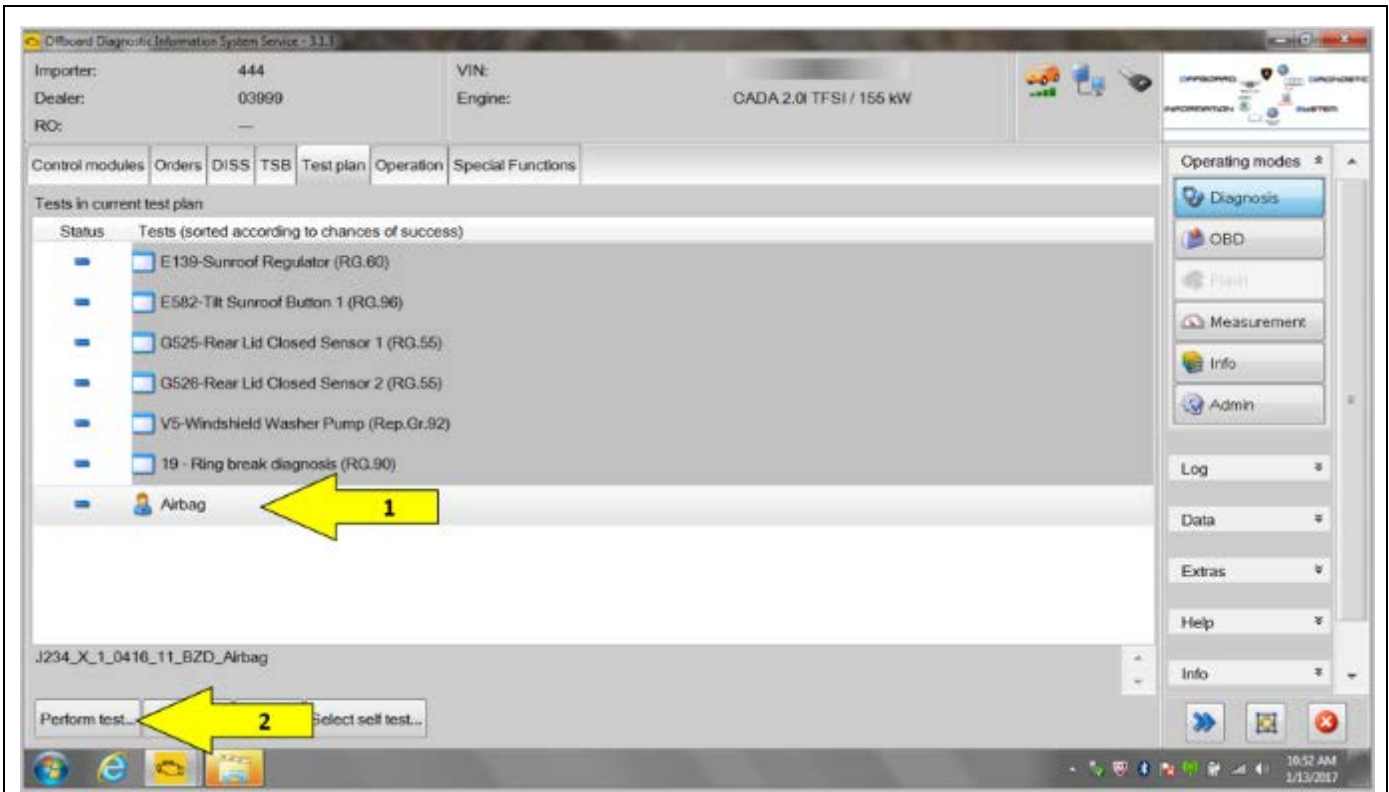

- Highlight the “Airbag” test plan <1>.
- Select “Perform test...” <2>.

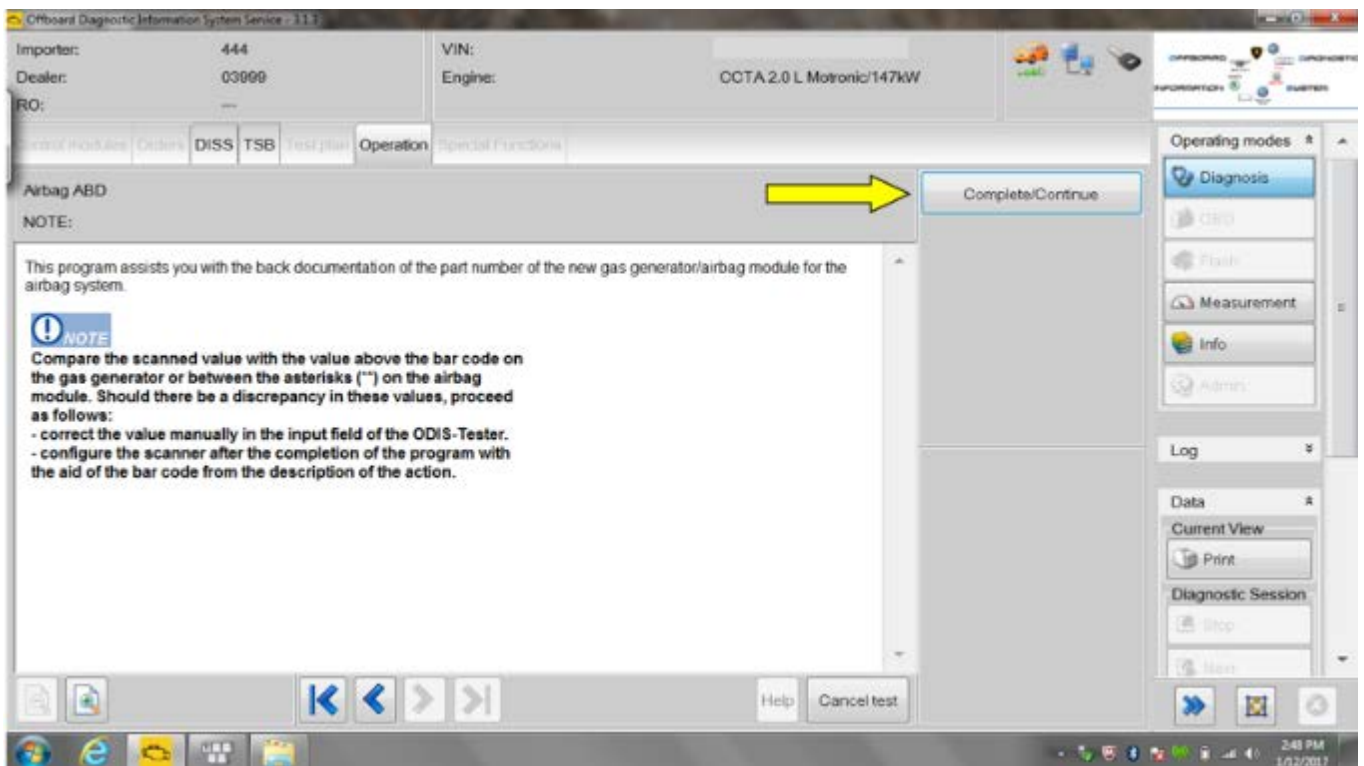

- Scanning the bar code during this test plan step calibrates the scanner to avoid error messages.
- Scanning the calibrating bar code may not have to be done every time. Only when the scanner requires calibration. You will know if the scanner needs calibrating if the scanner does not scan the airbag's bar code.
- If the airbag bar code cannot be scanned, then print out the barcode shown below and scan the printout.

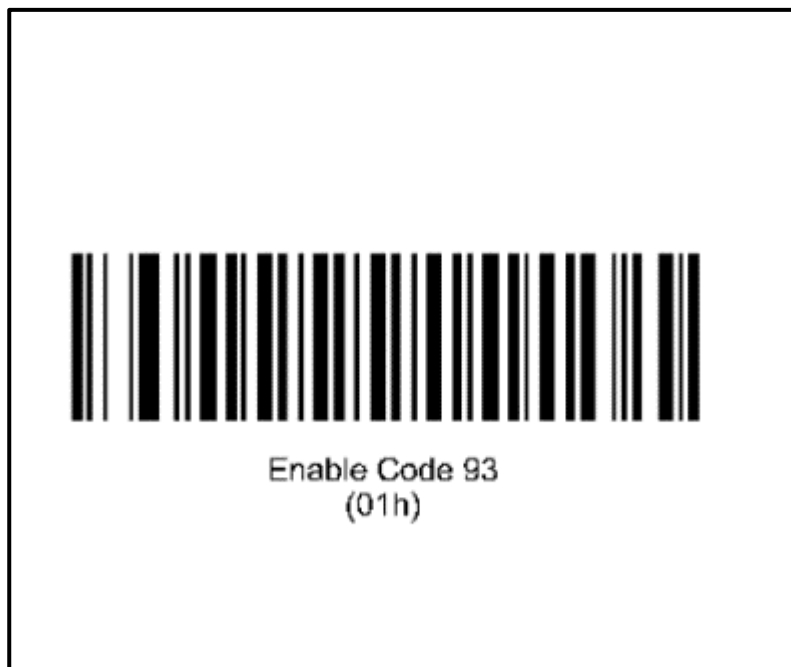

- After calibrating the scanner, select **“Complete/Continue”**



- Scan the data matrix code <arrow> of the new airbag at a distance of about 15 cm, then follow the instructions on screen.

⚠ CAUTION

Ensure the correct airbag data matrix code is scanned at this time.

| <u>Criteria</u> | <u>Model</u> | <u>Part Number</u> |
|-----------------|--------------|--------------------|
| 4F | A6 | 4F1880204F |
| 8E | A4 | 8E1880204F |
| 8F | A4 Cabriolet | |

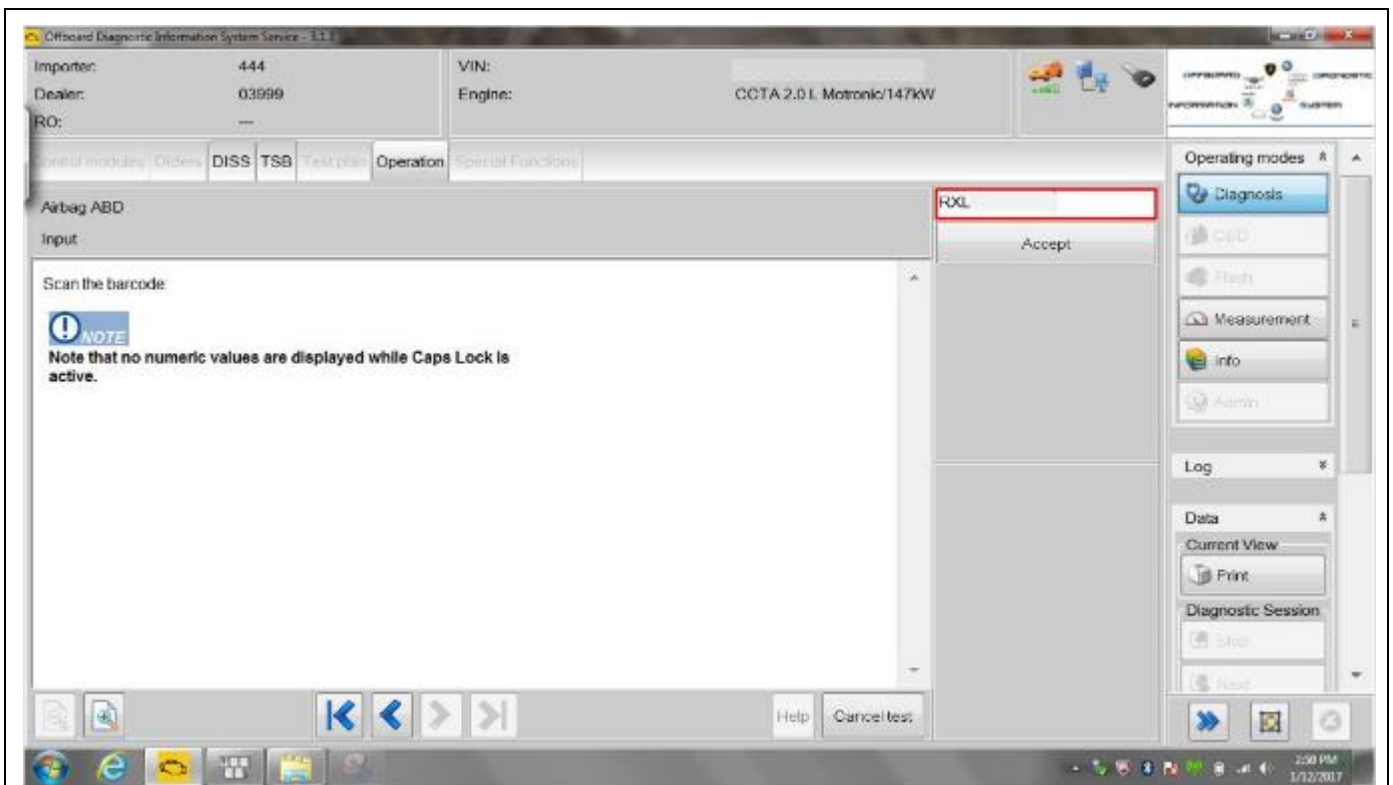

- Once the new passenger airbag has been successfully scanned, press **“Accept”**.
- If no value appears, recalibrate the scanner.
- A valid GeKo ID will need to be entered in order to upload the new airbag identification.

Continue to Section D.

Section D – Passenger Airbag Replacement

NOTE

Before disconnecting the battery, it is recommended to record the customer's radio presets so they can be restored before returning vehicle to the customer.

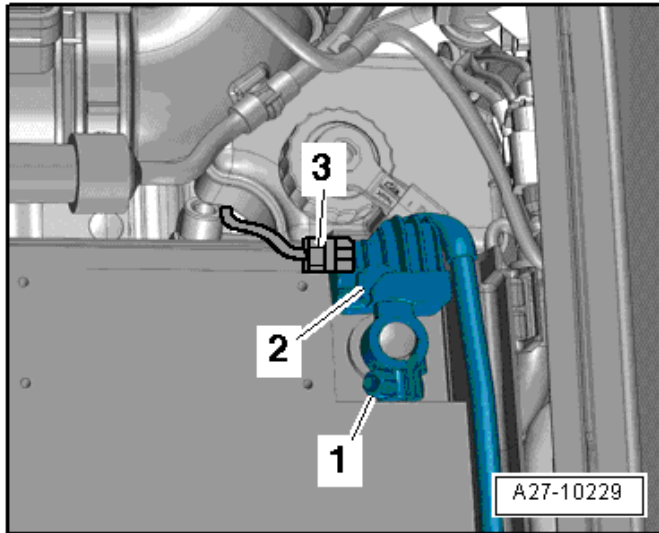

WARNING

Accident risk. When working on pyrotechnic components (such as airbags and belt tensioners), the battery must be disconnected with the ignition switched **ON**.

- Turn **ON** the ignition.
- Move the passenger seat to the most rearward position.
- Fully recline passenger seat.

CAUTION

Reclining the passenger seat before disconnecting the battery allows for additional safety in the event Terminal 15 power is not restored when reconnecting the battery at the end of the repair.

- Access the battery.
- Make sure the ignition is turned **ON**.
- Loosen the nut <1>.
- Remove and isolate the battery ground cable terminal <2> from the battery terminal.

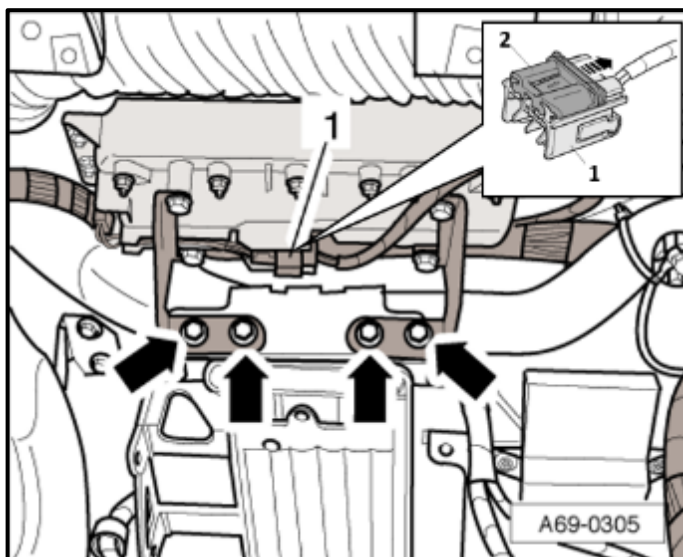

WARNING

Before handling pyrotechnic components (for example, disconnecting the connector), the person handling it must "discharge static electricity". This can be done by touching the door striker, for example.

For A6 Models:

- Remove and discard instrument panel bolts <arrows> on central tube.
- Press securing catch <2> in <direction of arrow> until connection disengages.
- Remove electrical connector <1>.

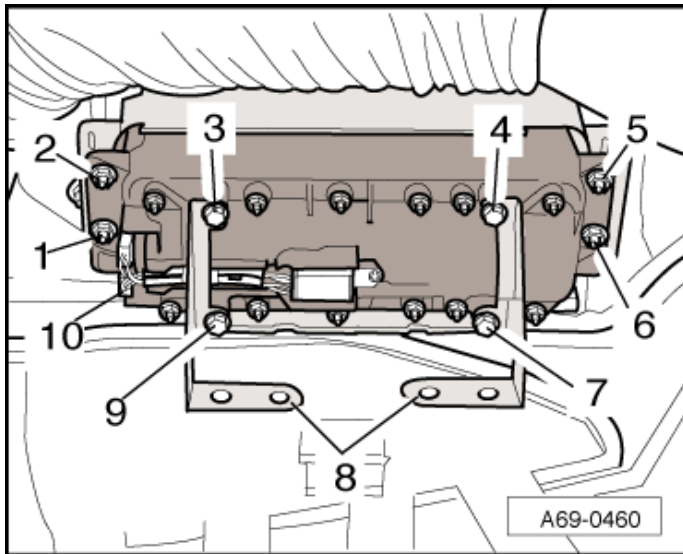

- Remove and discard bolts <3, 4, 7 and 9> and remove airbag unit bracket <8>.
- Remove and discard nuts <1, 2, 5 and 6>.
- Remove passenger airbag.

⚠ WARNING

Set the airbag down so the airbag fabric faces upward.

- Install new passenger airbag, with new nuts <1, 2, 5 and 6> and torque to 9 Nm.
- Install bracket <8>, with new bolts <3, 4, 7 and 9> and torque to 6 Nm.

| Part Number | Part Description |
|-------------|---|
| 4F1880204F | Passenger Airbag |
| N 02300213 | M6 Self Locking Nut <1, 2, 5 and 6> |
| N 10305302 | M6 x 20 Bolt (airbag bracket to airbag) <3, 4, 7 and 9> |

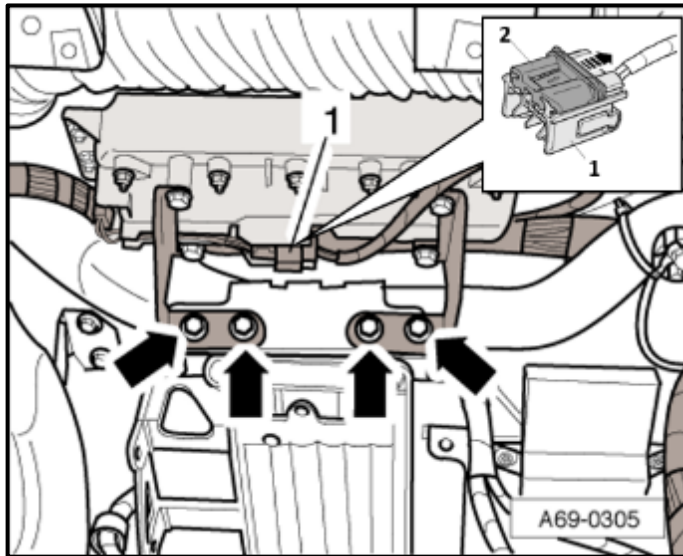

- Install new bolts <arrows> on central tube and torque to 9 Nm.

| Part Number | Part Description |
|-------------|---|
| N 90654602 | M6 x 18.25 Bolt (airbag bracket to central tube) <arrows> |

- Install electrical connector <1>.

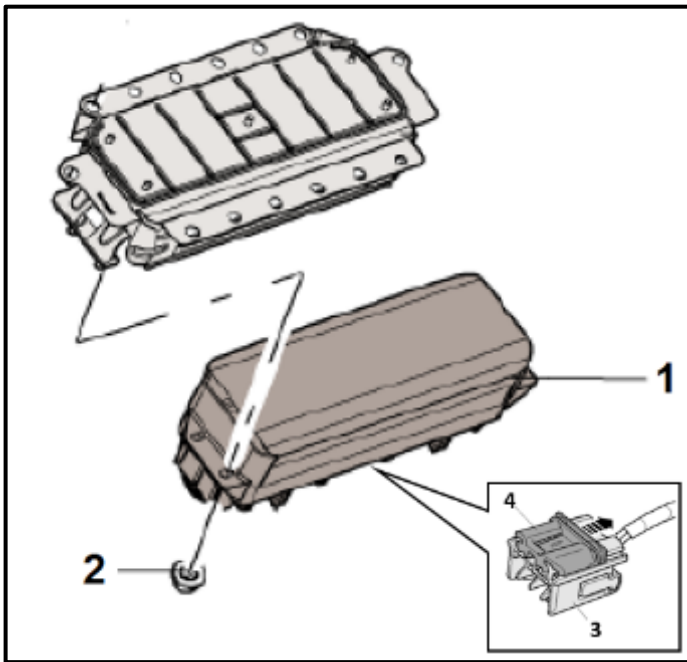

⚠ WARNING

Before handling pyrotechnic components (for example, disconnecting the connector), the person handling it must “discharge static electricity”. This can be done by touching the door striker, for example.

For A4 and A4 Cabriolet Models:

- Press securing catch <4> in <direction of arrow>.
- Remove electrical connector <3>.
- Remove and discard passenger airbag nuts <2> from passenger airbag <1>.
- Remove passenger airbag

⚠ WARNING

Set the airbag down so the airbag fabric faces upward.

- Install new passenger airbag <1>, with new nuts <2> and torque to 9 Nm.

| Part Number | Part Description |
|-------------|---------------------|
| 8E1880204F | Passenger Airbag |
| N 90887703 | M6 Self Locking Nut |

- Install electrical connector <3>.

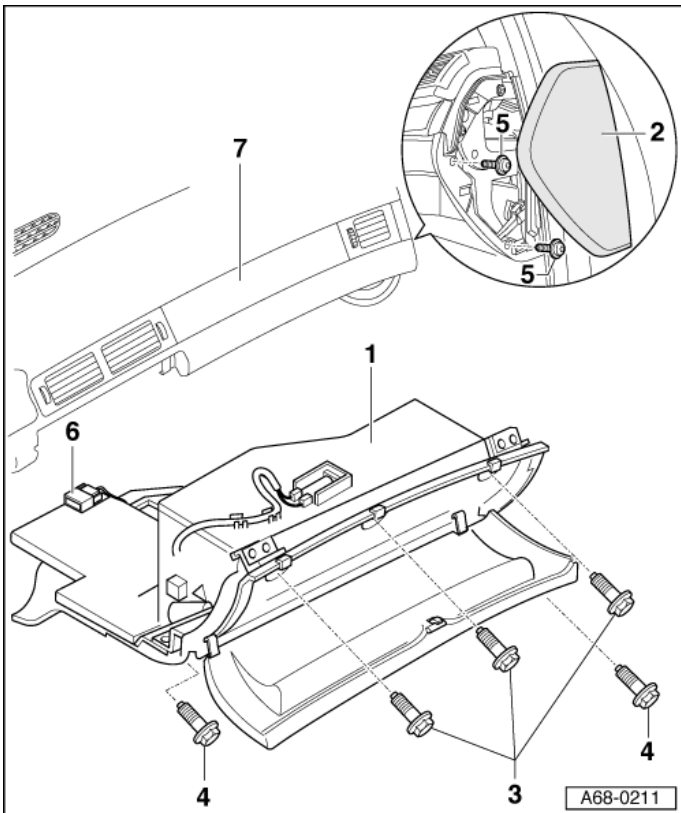

Continued for all models:

- Install connector <6> to glove compartment light.
- Install glove compartment.
- Install bolts <3, 4 and 5> and torque to 5 Nm.
- Install instrument panel cover <2>.

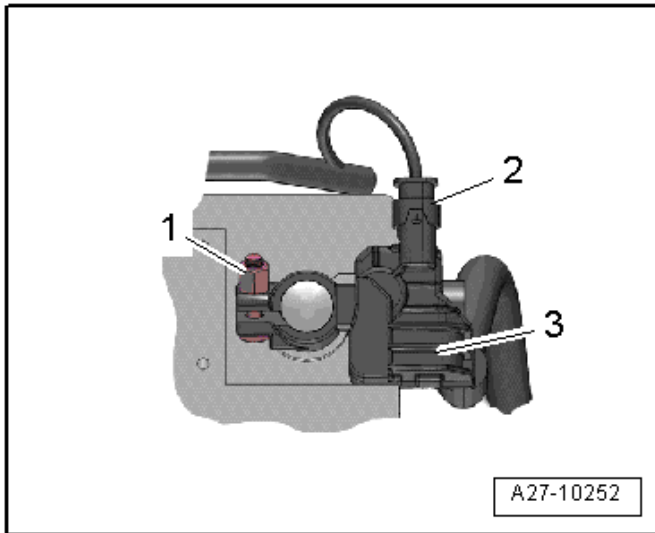

⚠ WARNING

Ignition must be **ON** when connecting battery. If pyrotechnic components (e.g. airbag, belt tensioner) are not repaired correctly, they may deploy unintentionally after connecting battery. There must not be anyone inside the vehicle when connecting the battery.

- If equipped, disconnect the connector <2> from the Battery Monitoring Control Module -J367-.
- Connect the battery ground cable terminal by hand to the battery negative terminal.
- Torque the nut <1>:
 - A6 Models = 6 Nm.
 - A4/A4 Cabriolet Models = 7.5 Nm.
- If equipped, reconnect the connector to the Battery Monitoring Control Module -J367-.
- Install battery covers.
- If equipped, install battery strap.
- If necessary, install luggage compartment storage area floor and if equipped, cover for spare tire.
- Cycle the ignition off and back on.
- Bring passenger seat to an upright position.
- Store previously recorded radio presets (if necessary).
- Set clock to local time.
- Activate the power window regulator one-touch up/down function.
- Check the DTC memories of all the control units and erase under-voltage faults if necessary.

! NOTE

After connecting the power supply, the ABS warning lamp may only go out after the vehicle has been driven a short distance.

Proceed to Section E.

Section E – Campaign Completion Stamp

I certify that this campaign
has been performed in strict
accordance with the applicable
Audi repair procedure.

SAGA Code: _____
Technician: _____
Date: _____

Item#: AUD4927ENG

-OR-

Je certifie que cette
campagne de rappel a été
exécutée suivant les strictes
directives de réparation
d'Audi

Code de SAGA: _____
Technicien: _____
Date: _____

Item # AUD4927FRE

- Once the campaign has been completed, the technician should stamp the repair order.
- Stamps are available for ordering through the Compliance Label Ordering Portal.

Repair is Complete, Proceed to Appendix B
(Mandatory Takata Part Return Process).

Appendix A – Warning and Safety Precautions

WARNING

General Safety Precautions when Working with Pyrotechnic Components:

- Pyrotechnic components always contain propellant that generates a gas during combustion. In some components, there is also a supply of pressurized gas to ensure this gas is generated
- This pressurized gas is stored under high pressure in a compressed gas container. Pyrotechnic components are triggered by electrical/mechanical igniters.
- Only trained personnel should perform testing, assembly and servicing work. Airbags do not have a replacement interval.
- Never check with test lamps, voltmeter or ohmmeters.
- Only check pyrotechnic components when they are installed in the vehicle using vehicle diagnosis, testing and information systems approved by the manufacturer.
- When working on pyrotechnic components and the airbag control module, disconnect the battery ground strap while the ignition is switched on. Then cover the negative terminal.
- Wait 10 seconds after disconnecting the battery.
- The ignition must be SWITCHED ON when connecting the battery. There should not be anyone inside the vehicle when doing this.
- Exception: vehicles with batteries in the passenger compartment. In this case, stay outside the range of the airbags and seat belts.
- Wash your hands after touching ignited pyrotechnic components from the restraint system.
- Do not open or repair pyrotechnic components. Use only new components to reduce the risk of injury.
- Do not install pyrotechnic components that have fallen onto a hard surface or show signs of damage.
- Discharge static electricity before handling pyrotechnic components, for example before disconnecting the electrical connector. This can be done by touching grounded metal objects such as the door striker pin.
- Install pyrotechnic components immediately after removing them from their transport packaging. If you must stop working, store the pyrotechnic component in its original transport packaging.
- Do not leave pyrotechnic components lying in the open unattended.
- Do not treat pyrotechnic components with grease, cleaning solutions or similar products.
- Do not expose pyrotechnic components to temperatures above 100 °C, even for brief periods of time.
- People in the immediate vicinity of the workplace must be protected from possible noise and projectiles.
- Pyrotechnic components can trigger unintentionally.
- In the event of deployment:
 - Single-stage inflators: allow airbag to cool down completely. Wait at least 10 minutes before handling.
- Two-stage inflators: wait for second airbag ignition. Allow airbag to cool down completely. Wait at least 10 minutes before handling.

Appendix B – Mandatory Takata Parts Return Process

NOTE

NOTE: International (including Mexico and Canada), Hawaii, Alaska, Puerto Rico, and US Virgin Islands dealers **CANNOT** follow below shipping instructions. Instead, dealerships in these locations **MUST** contact the following Takata/Menlo USA representative directly for shipping instructions: Miguel Prigadaa – Tel #: 210-250-5078 or Email: MLGTakataRestrains_International@menloworldwide.com. Or they can email the attached form to Menlo/XPO, (email is in the form) & they will make arrangements with Crane Worldwide to arrange pick up. As info, both emails go to the same international people that arrange the freight. MLGTakataRestrains_International@menloworldwide.com; SCTakataRestrains_International@XPO.com

NOTE: For Continental US 48 State dealerships, please follow steps 1-8 below.

1. Shipping Documents

a) Box Label

- Supplied with each Kit
- To be affixed to each box



b) Over-pack Label

- To be supplied by XPO
- To be affixed to the outside of each pallet



c) Bill of Lading

- To be supplied by XPO.
- Print 2 copies: 1 for Dealer Records, 1 for LTL Driver



d) ERG Document

- To be supplied by XPO.
- To be provide by the Dealer to the LTL Driver for each shipment



5. Shipping Instructions – Prepare the Pallet

- Accumulate and palletize Kits
- Arrange Kits on Pallet as pictured here
 - 20 boxes per row/layer (5x4)
 - 10 rows/layers per pallet (200 boxes)
- Shrink-wrap Kits to Pallet
- Affix Over-pack Label on (1) side of Pallet (Not on Top)



6. Shipping Instructions – Schedule LTL Pickup

- Upon Accumulating 200 kits (1 Over-pack/Pallet) Minimum
 - Call XPO at 1-888-708-5712
 - If 200 Kits have not been accumulated in 30 days, please call XPO for direction
- Have the following Information Available
 - Dealer #
 - Quantity of Over-packs/Pallets
 - Quantity of Passenger Inflator Kits on each Pallet
 - Email Address where shipping Documentation can be received

2. Packing Instructions

a) Confirm box is in acceptable condition. If a new box is needed, follow the New Box instructions located In Box 8 of this page.

b) Place the un-deployed air bag inflator in the "cradle" of the box insert.



3. Closure Instructions

a) Close the top box flap, per box closure instructions located on front panel of box.

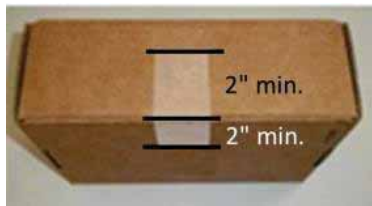

4. Shipping Instructions - Label each Box

a) New Labels will begin shipping in each kit starting mid June, 2015

1. VW/Audi Inflator Kit will contain this two-part label.
2. Peel off 'Ship To' Label.
3. Affix Label to Box. Do not cover up Class 9 Marking.

7. Shipping Instructions – Ship

- Give 1 Copy of BOL and 1 Copy of ERG to Driver
- Retain 1 Copy of BOL for Dealership records and archive for 2 Years

8. Requesting a New Box / Shipping Labels

If a new box or replacement shipping labels are needed, please contact the representative listed below by phone or email to request replacement materials.

Primary Contact: XPO Customer service Rep- Tel #: 210-250-5079

E-Mail: SCFieldAction.14305@xpo.com

To help expedite your request, please be prepared to provide the following information:

- Serial number on the original box
- What Type of shipping material needed
 - Replacement Box
 - Two Part Return Label
 - Bill of Lading
 - ERG Form
- Dealer Shipping Information
 - Contact name
 - Dealer Address
 - Phone Number



U.S. Only

NOTE

Crane Worldwide Logistics will arrange pick-up of all return Takata product. Dealers **MUST** follow directions on attached sign up form and pick-up request instructions.

If you have any issues, questions or require additional information regarding shipping, contact the following Takata/Menlo USA representative directly:

Miguel Prigadaa

Tel number: 210-250-5078

Email: MLGTakataRestrains_International@menlowworldwide.com

NOTE: For reference purposes only, see steps 1-8 below.

Canadian Dealers - Do Not Contact XPO

Gillian Guilbert, Campaign Specialist

Tel number: (905) 428-4601

E-mail: Warranty.campaigns@vw.ca ou Warranty.campaigns@audi.ca

1. Shipping Documents

a) Over-pack Label

- To be supplied by carrier
- To be affixed to the outside of each pallet

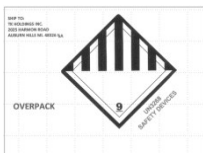

b) Bill of Lading (BOL)

- To be supplied by carrier
- Print 2 copies: 1 for Dealer Records, 1 for truck Driver



c) ERG Document

- To be supplied by carrier
- To be provided by the Dealer to the truck Driver for each shipment



2. Packing Instructions

a) Confirm box is in acceptable condition.

b) Place the un-deployed air bag inflator in the "cradle" of the box insert.



3. Closure Instructions

a) Close the top box flap, per box closure instructions located on front panel of box.



4. Shipping Instructions - Label each Box

a) This step is **only** necessary if label is included in box.

- VW/Audi Inflator Kit will contain this two-part label:
- Peel off 'Ship To' Label.
- Affix Label to Box. Do not cover up Class 9 Marking.

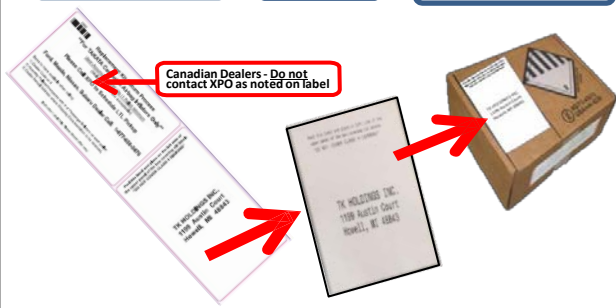

5. Shipping Instructions – Prepare the Pallet

- Accumulate and palletize Kits
- Arrange Kits on Pallet as pictured here
 - 20 boxes per row/layer (5x4)
 - 10 rows/layers per pallet (200 boxes MAX)
- Shrink-wrap Kits to Pallet
- Affix Over-pack Label on (1) side of Pallet (Not on Top)
- Kits **cannot** be shipped in a master carton. If not enough to palletize, kits can be returned in their individual Boxes with dangerous goods markings visible. Select "via small package" when shipping individually



6. Shipping Instructions – Schedule LTL Pickup

a) Upon Accumulating 200 kits (1 Over-pack/Pallet) or **30 days since last shipment**:

- Follow request instructions on pick-up
- Have the following Information Available
 - Dealer Number
 - Quantity of Over-pack Pallets(200) or individual boxes
 - Quantity of Passenger Inflator Kits on each Over-Pack Pallet
 - Email Address where shipping Documentation can be received

7. Shipping Instructions – Ship

- Give 1 Copy of BOL and ERG to driver
- Retain 1 Copy of BOL for Dealership records and archive for 2 Years

8. Requesting a New Box / Shipping Labels

If a new box or replacement shipping labels are needed, please email to request replacement materials.

E-Mail: MLGTakataRestrains_International@menlowworldwide.com

To help expedite your request, provide the following information:

- Serial number on the original box
- What Type of shipping material needed
 - Replacement Box
 - Two Part Return Label - * if included
 - This picture may appear different on the box
- Dealer Shipping Information
 - Contact name
 - Dealer Address
 - Phone Number



CANADIAN DEALER DO NOT CONTACT XPO

Do not ship with label inside the box
Label on the box will vary as per country of origin
Please file all tracking documents
Contact your Campaign Specialist