

**2003 – 2008 Mazda6, 2006-2007 Mazdaspeed6, and 2004-2006 MPV - PASSENGER AIR BAG  
SAFETY RECALL 2618F**

---

August 13, 2024. Added Do Not Drive designation for this campaign. Warranty information guidelines for rentals and towing were also updated.



**ATTENTION ALL MAZDA DEALERS:**

**THIS CAMPAIGN HAS BEEN DESIGNATED AS A DO NOT DRIVE RECALL. IF THE CUSTOMER REQUESTS TO TOW THE VEHICLE TO THE DEALER, PLEASE HONOR THE REQUEST AND REVIEW GUIDELIENS FOR CLAIMING TOWING BELOW. THE VEHICLE CAN ALSO BE TOWED BACK TO THE CUSTOMER HOME/WORK, ETC.. UPON REQUEST. ALL TOWS ABOVE \$1,000 WILL REQUIRE WARRANTY PREAUTH GOODWILL PRIOR TO TOWING.**

**MOBILE REPAIR BY MAZDA DEALER: THIS OPTION IS ENCOURAGED AND CLAIM INFORMATION IS CONTAINED IN EACH TAKATA RECALL. IF ADDITONAL COSTS ARE NEEDED TO COMPLETE A MOBILE REPAIR PLEASE FILL OUT DEALER RECALL HELP ON ONEMAZDA.**

**PLEASE DO NOT DENY A CUSTOMER REQUEST TO TOW WITHOUT SPEAKING WITH YOUR DISTRICT SERVICE MANAGER OR FILL OUT DEALER RECALL HELP ON ONEMAZDA.**

**LOANER VEHICLE: MCVP / RENTALS: A CUSTOMER CAN RECEIVE A MCVP OR RENTAL DURING THE REPAIR PERIOD, BUT MUST PICK UP THE VEHICLE WITHIN 48 HOURS OF THE REPAIR. ALL RENTALS GREATER THAN THE 2 DAY RENTAL POLICY MUST BE PRE-APPROVED UNLESS THE DEALER IS THE DSA TIER DOES NOT REQUIRE AUTHORIZATION.**

**UNREPAIRABLE VEHICLES: FILL OUT DEALER RECALL HELP ON ONEMAZDA WITH CLEAR PHOTOS AND DETAILED EXPLANATION ON WHY YOU CANNOT REPAIR. DO NOT LET THE CUSTOMER LEAVE UNTIL YOU HEAR BACK FROM THE RECALL HELP TEAM.**

**A. VEHICLE INSPECTION PROCEDURE**

1. Verify that the vehicle is within the following ranges:

Zone A

Model	Note
2003-2008 Mazda6, 2006-2007 Mazdaspeed6, 2004-2006 MPV	Originally sold or ever registered in Hawaii, California, Texas, Louisiana, Mississippi, Alabama, Georgia, Florida, South Carolina

Zone B

Model	Note
2003-2008 Mazda6, 2006-2007 Mazdaspeed6, 2004-2006 MPV	Originally sold or ever registered in Arizona, Arkansas, Delaware, District of Columbia, Illinois, Indiana, Kansas, Kentucky, Maryland, Missouri, Nebraska, Nevada, New Jersey, New Mexico, North Carolina, Ohio, Oklahoma, Pennsylvania, Tennessee, Virginia, West Virginia

Zone C

Model	Note
2003-2008 Mazda6, 2006-2007 Mazdaspeed6, 2004-2006 MPV	Originally sold or ever registered in Alaska, Colorado, Connecticut, Idaho, Iowa, Maine, Massachusetts, Michigan, Minnesota, Montana, New Hampshire, New York, North Dakota, Oregon, Rhode Island, South Dakota, Utah, Vermont, Washington, Wisconsin, Wyoming

- If the vehicle is within the above ranges, proceed to Step 2.
  - If the vehicle is not within the above ranges, return vehicle to the customer or inventory.
2. Perform a Warranty Vehicle Inquiry using your eMDCS System and inspect vehicle for Campaign Labels **Recall 2618F** attached to the vehicle's hood or bulkhead. Refer to eMDCS System - Warranty Vehicle Inquiry Results table below.

**NOTE:** Be sure to verify Recall number as the vehicle may have multiple Recall labels.

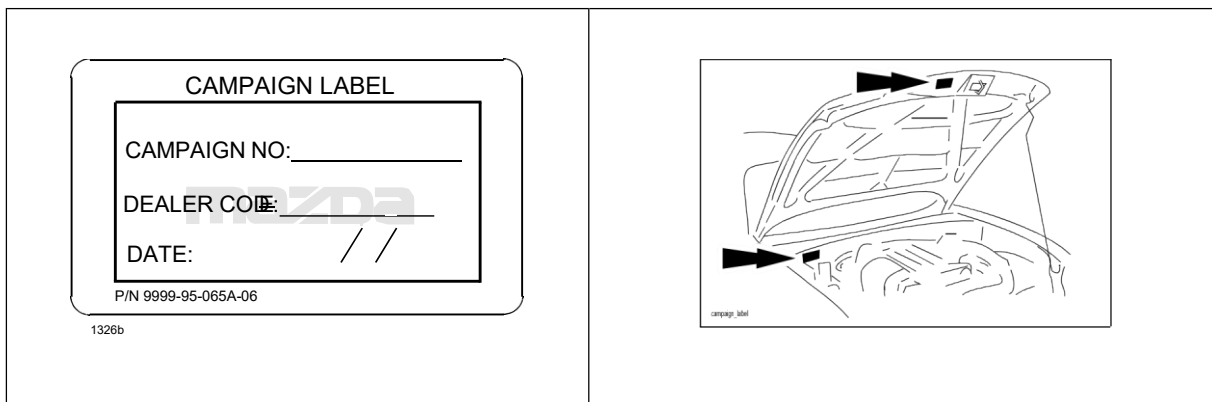

**eMDCS System - Warranty Vehicle Inquiry Results:**

If eMDCS displays:	Campaign Label is:	Action to perform:
RECALL 2618F OPEN	Present	Contact the Warranty Hotline at (877) 727-6626 option 3 to update vehicle history.
	Not present	Proceed to "B. REPAIR PROCEDURE".
RECALL 2618F CLOSED	Present	Return vehicle to inventory or customer.
	Not present	Proceed to "C. CAMPAIGN LABEL INSTALLATION".
RECALL 2618F is not displayed	Does not apply	Recall does not apply to this vehicle. Return vehicle to inventory or customer.

## B. REPAIR PROCEDURE

Year / Model	Page No.
2003-2008 Mazda 6, 2006-2007 Mazdaspeed6	3

2003-2008 Mazda6 2007-2007 Mazdaspeed6: (Part Number: GJYB-57-K80)

### Passenger-Side Air Bag Inflator Replacement Procedure:

Parts Information: The service parts are available in one box



Inflator APPS-7



Nuts(x4)



Collar C

Collar A



Stopper Plate



Felt Tape(x2)



### Outline:

1. Remove the inflator from the passenger-side air bag module (A), then replace it with a modified one (B)

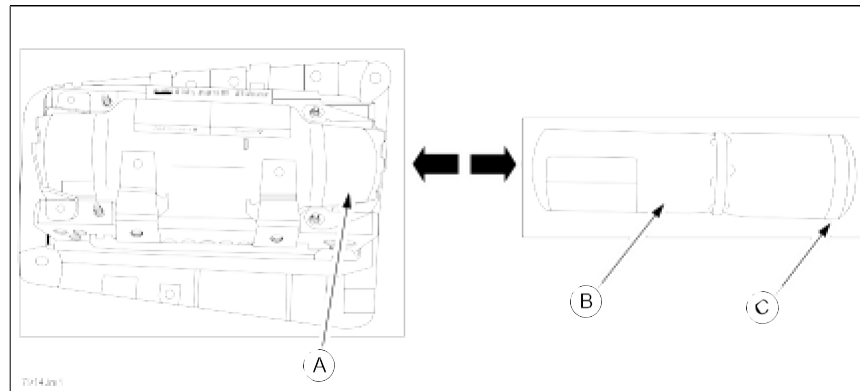

2. Pack and return the removed inflator as follows:

**IMPORTANT:** Be sure to follow the packing and shipping instructions provided in the carton and in Attachment IV, Air Bag Inflator Return Instructions.

**CAUTION:**

- Use the same carton which was used to deliver a new inflator. It is a specialized box that is internationally accepted for shipping an inflator.
- Pack the old inflator in the box exactly in the same manner as the new inflator was packed.

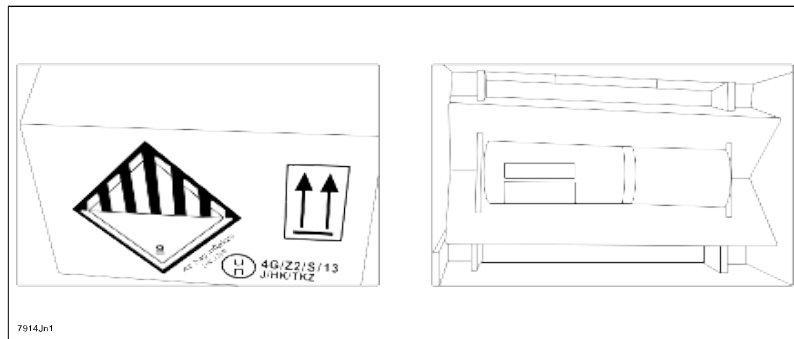

### Air Bag Module Removal:

#### WARNING:

- Perform the replacement in a clean environment. Oil, grease, water, etc. on components may cause the air bag modules to fail to deploy in an accident, which may cause serious injury. Do not allow oil, grease, water, etc., on components.
  - Inserting a screwdriver, etc., into the connector of an air bag module may damage the connector and cause the air bag module to deploy improperly, which may cause serious injury. Do not insert any foreign objects into the connector.
  - Do not disassemble the vehicle, other than instructed here.
  - Do not make an attempt to directly supply electrical power to the module and the inflator.
  - Keep the module facing upwards at all times, except during replacement.
  - Do not use the module and new inflator if they were dropped on the ground.
  - Avoid module and inflator exposure to temperatures of 194 degrees F (90 degrees C) or more.
1. Turn the ignition switch to the LOCK position.
  2. Record the customer's preset radio stations.
  3. Disconnect the negative battery cable and wait for one (1) minute or more.
  4. Remove the glove compartment.
    - a. Detach the string from the glove compartment.

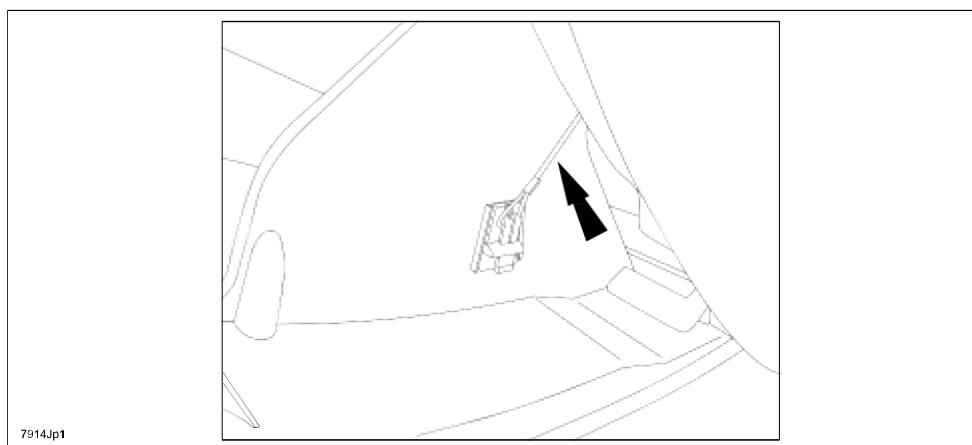

- b. Press the glove compartment stoppers (A) inward.
- c. Lower the glove compartment (B) downward and pull the clips (C) to remove it.

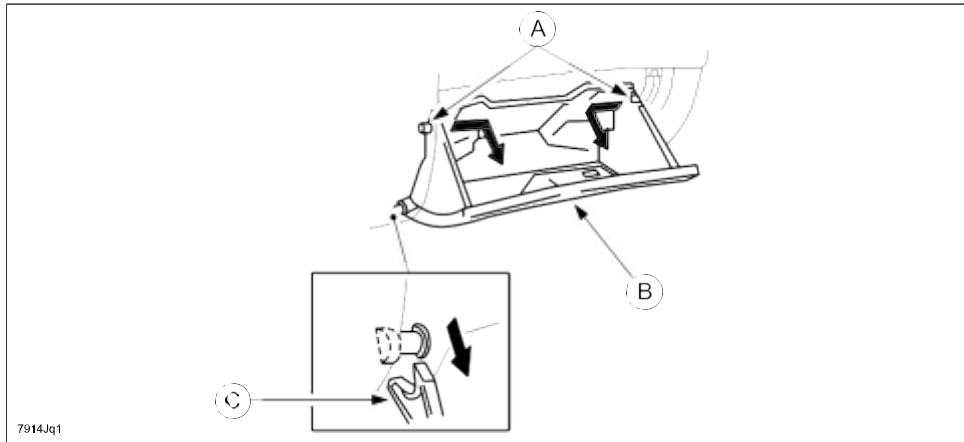

5. Remove the navigation unit (if equipped).
  - a. Remove the bolts.
  - b. Remove the navigation unit.

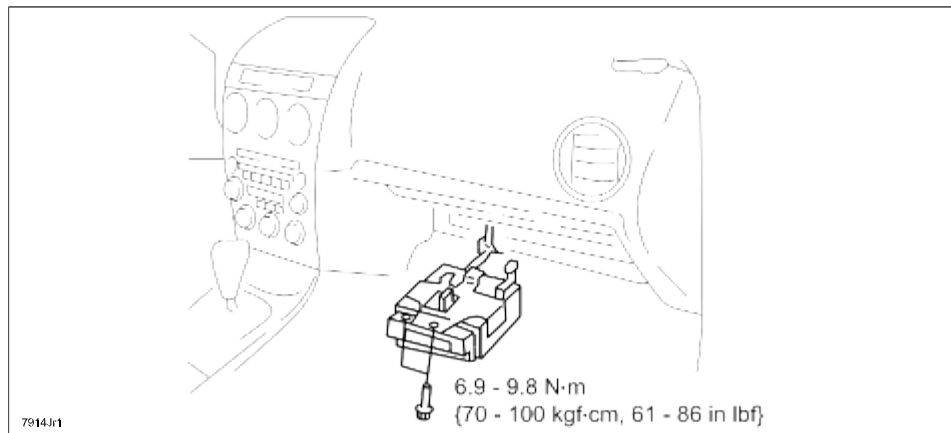

6. Remove the air bag module.

**CAUTION:**

- Be careful when prying out the stopper plate. Otherwise, damage to the stopper plate could occur.
  - The stopper plate must be pried up before disconnecting the connector. Otherwise, the connector could be damaged if trying to disconnect it with the stopper plate engaged.
  - Use extreme care when disconnecting the connector. Otherwise, damage to the connector could occur.
- a. Using a flathead screwdriver, gently pry out the connector stopper plate.
  - b. Disconnect the connectors (A).

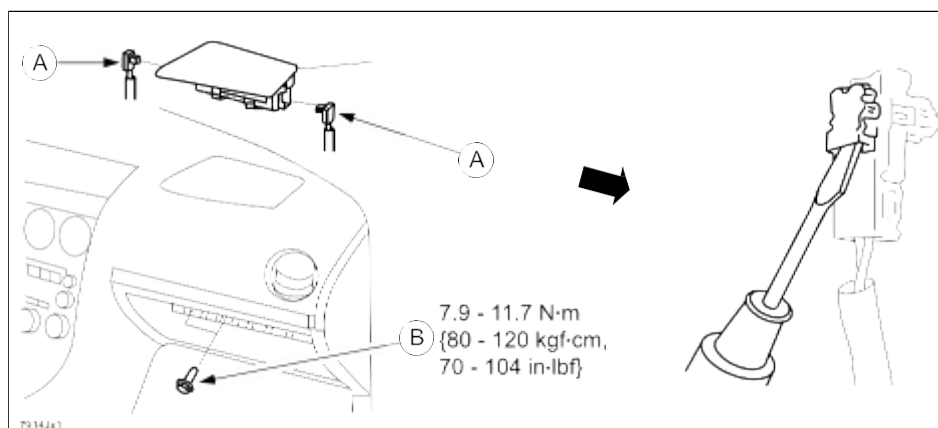

- c. Remove the bolt (B).

**NOTE:** If the connector is broken, replace the following new short code.  
Part number: GAY2-67-SH0

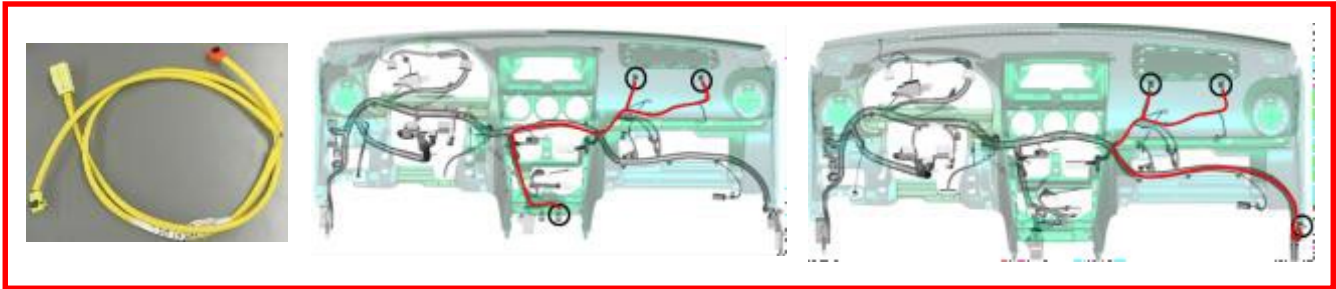

**NOTE:** If a stopper plate (A) is broken, replace the stopper plate with a new one, if applicable. Two types of stopper plates exist - an old type (GAY1-67-022) and a new type (GAY2-67-022). The exact switching date from the old type to the new type is unknown. Confirm the configuration of the stopper plate used on the vehicle in repair, and then use the one with the same configuration.

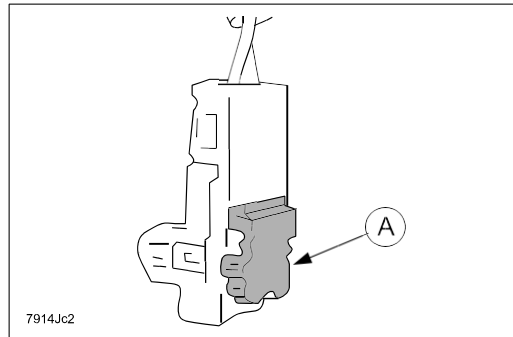

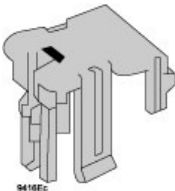
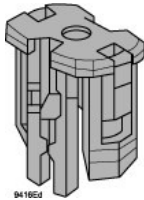
Old Type (GAY1-67-022)	New Type (GAY2-67-022)
	

7. Lay a protective cloth on the work bench, then place the air bag module on it to avoid any damage or scratches to the surface.

**Inflator Replacement:**

1. Loosen four (4) nuts until the upper surface of the nuts are aligned with the top edge of the screw thread.  
For easier inflator removal, depress the four (4) nuts and make a gap between the inflator and air bag module.  
**NOTE:** Do not depress excessively as the module body may detach.

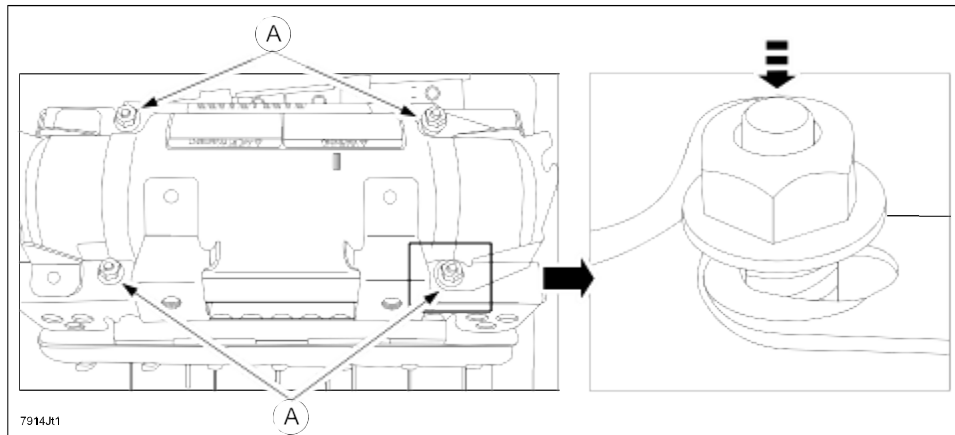

2. Remove the four (4) nuts, then remove the stopper plate from the air bag module.

**NOTE:** Discard all of the nuts and stopper plate.

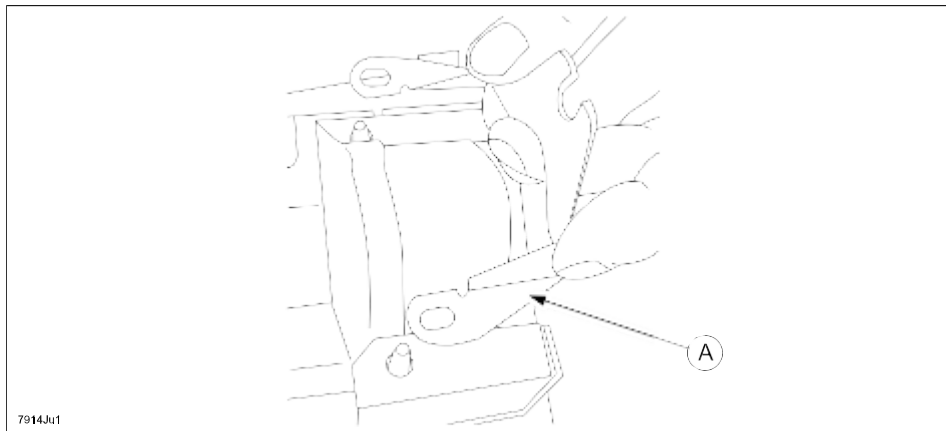

3. Push the inflator end with fingers, then remove it by sliding it in the direction shown below.

**IMPORTANT:** Return the removed inflator in the same carton in which the new part was received. Carefully follow the packing and shipping instructions included in the carton.

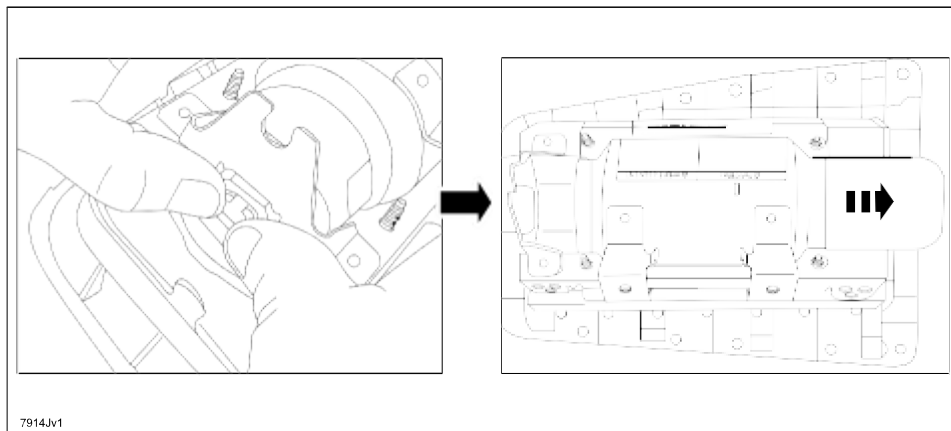



4. Paste the felt tape to Straight area (Orange area) the retainer. (Paste in two places)



Felt tape x 2

Straight area (Orange area)

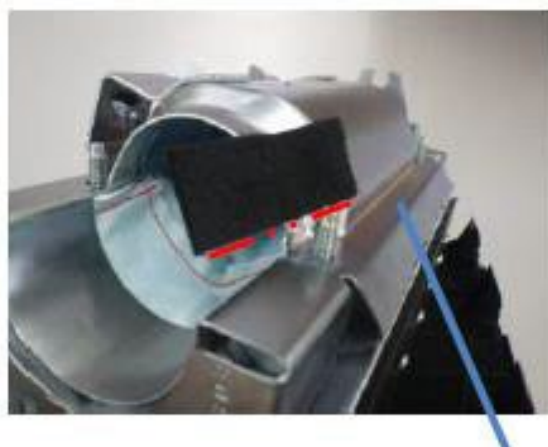
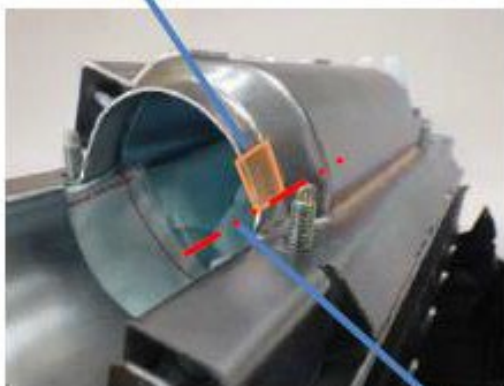

Reference position for pasting Edge of straight area. (Red line)  
※Do not jut out outside the Red line. (bolt side)

5. Fold it in half and paste it inside the retainer. Make it the same on both sides.

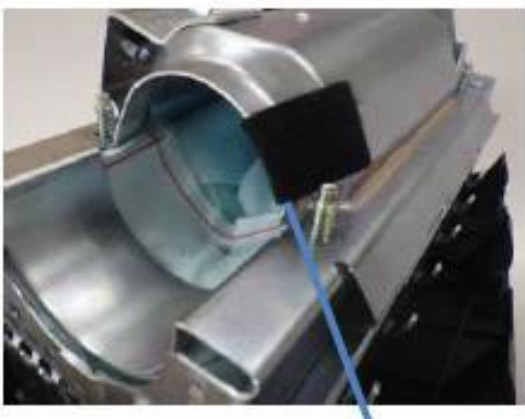

Fold it in half and paste it inside the retainer.



Make it the same on both sides.

6. Attach the collar A and C to replacement inflator.  
(Location of the collar A: The position is the 1st stage side of the inflator.)  
(Location of the collar C: The position is the 2nd stage side of the inflator.)

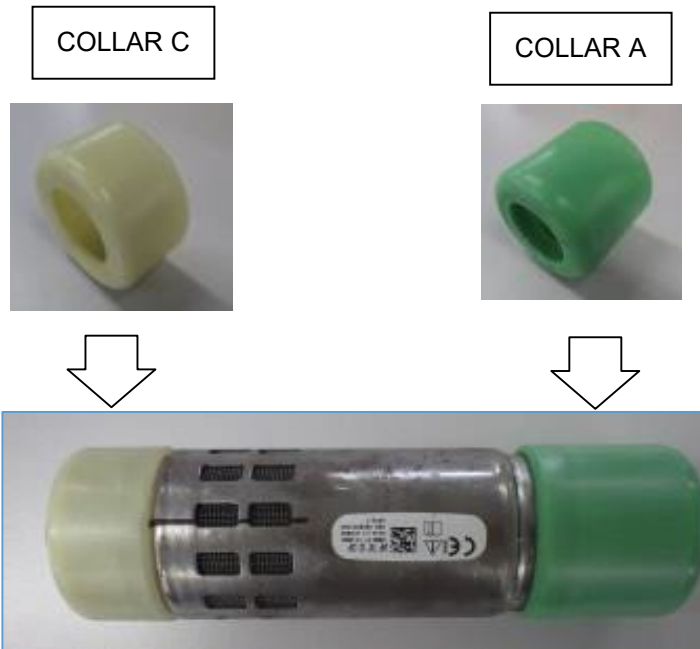

2nd stage  
(Orange connector)



1st stage  
(Yellow connector)

7. Insert to align the side of the retainer and guide line (Black line) of replacement inflator.

Retainer edge



Align guide line (Black line) with retainer edge.

8. Insert the inflator up to the position where it touches the stopper.  
The connector direction is 15 ° from the bottom of the retainer.

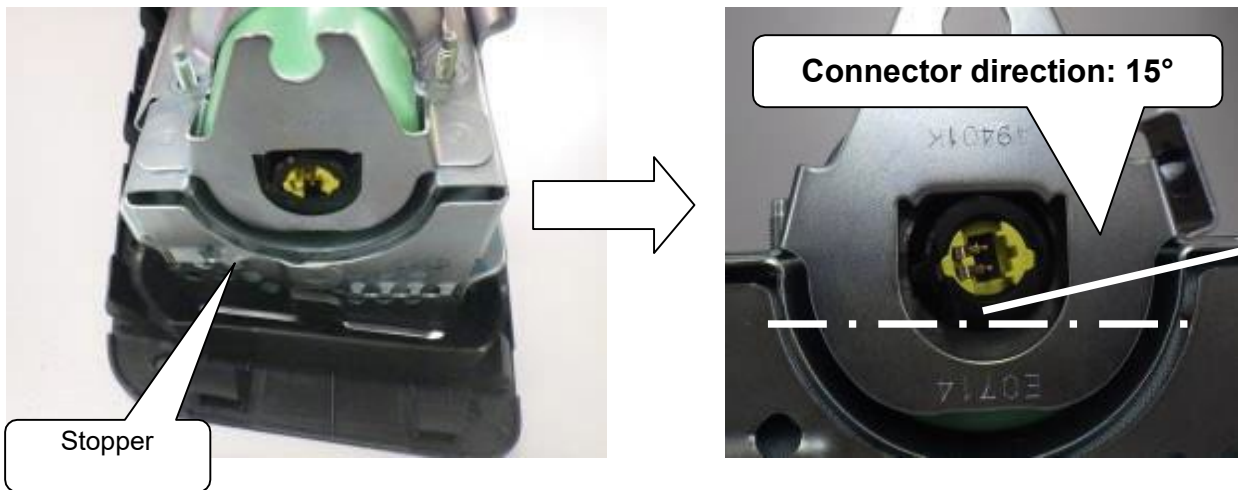

9. Set the new stopper plate (A) by gently pushing until it touches with the inflator side (B).

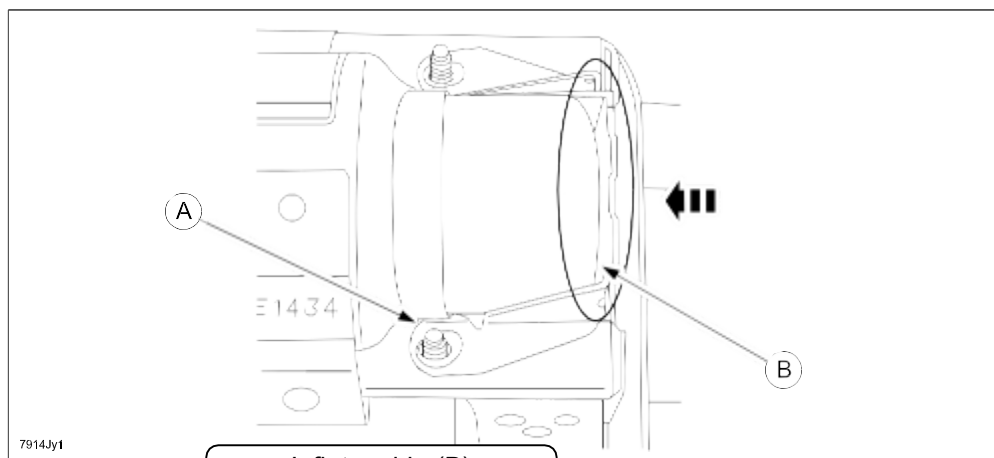

Inflator side (B)



New stopper plate (A)



10. Keeping the position above, hand tighten the four (4) new nuts.

11. Tighten the four (4) new nuts to the specified torque in the order shown below (1, 2, 3, 4).

**Tightening Torque: 35 +/- 1.8 in-lbf. {39.8 +/- 2.0 kgf-cm, 3.9 +/- 0.4 Nm} DO NOT USE ANY AIR TOOLS**

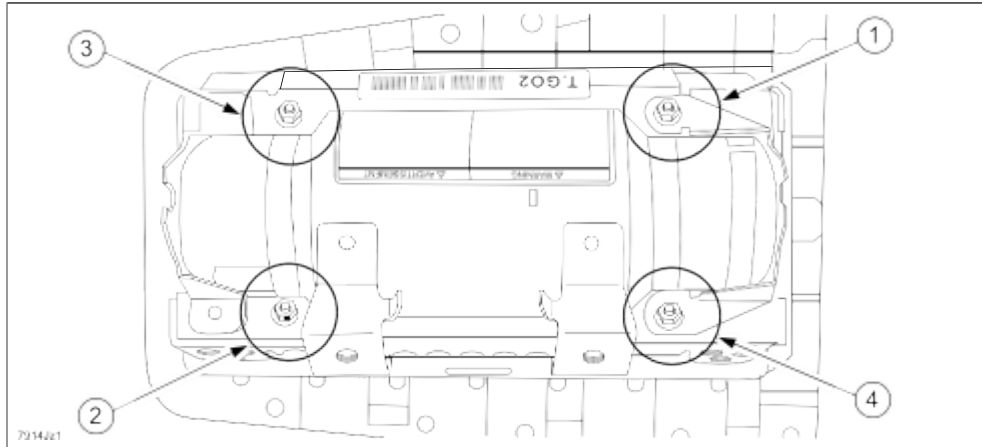

**Air Bag Module Reinstallation:**

1. Install the air bag module assembly.

2. Tighten the bolt (A) to the specified torque.

**Tightening Torque: 70 - 104 in-lbf. {80 - 120 kgf-cm, 7.9 - 11.7 Nm}**

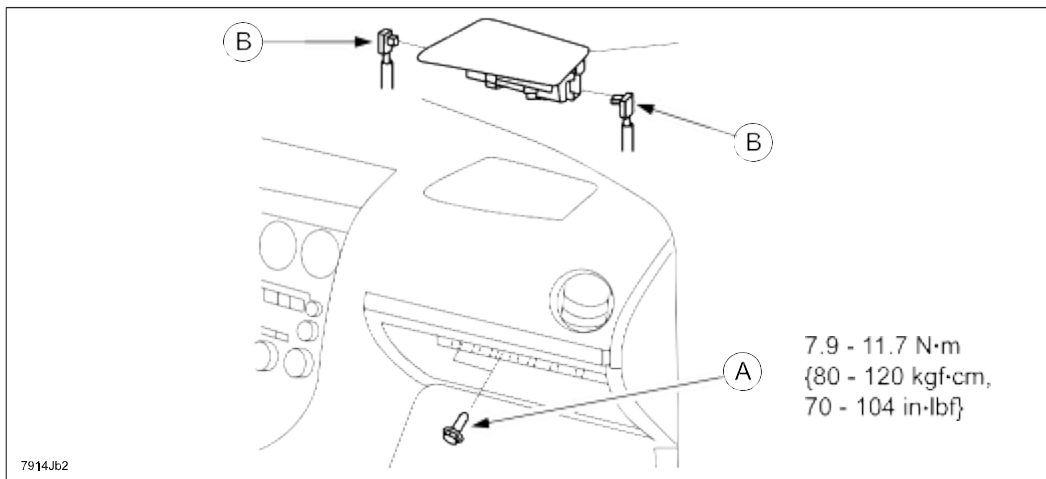

3. Re-connect the connectors (B) to air bag module.

4. Securely lock the connectors by depressing the stoppers (A) on the back of the connector.

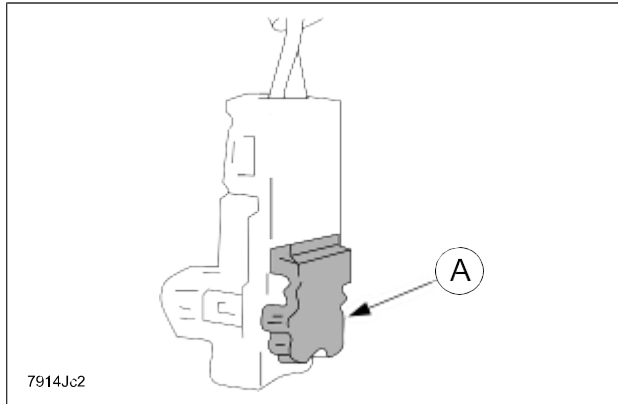

5. Reconnect the negative battery cable.
6. Turn the ignition switch to the ON position.
7. Verify that the air bag system warning light illuminates for approx. 6 sec., then goes out.

**NOTE:** If the air bag system warning light does not operate in the manner described above, there is a malfunction in the system. Inspect the system following the on-board diagnostic system procedure according to MS3 online or the Workshop Manual (section 08 Restraints).

8. Reinstall the navigation unit (if equipped).
9. Reinstall the glove box.
10. Re-enter the customer's preset radio stations.
11. Proceed to "C. CAMPAIGN LABEL INSTALLATION".

Year / Model	Page No.
2004 – 2006 MPV	14

2004 - 2006 MPV: (Part Number: GJYB-57-K80)

**Passenger-Side Air Bag Inflator Replacement Procedure:**

Parts Information: The service parts are available in one box.



**Inflator APPS-7**



**Nuts(x4)**



**Collar C**

**Collar A**



**Stopper Plate**



**Felt Tape(x2)**



**Outline:**

1. Remove the inflator from the passenger-side air bag module (A), then replace it with a modified one (B).

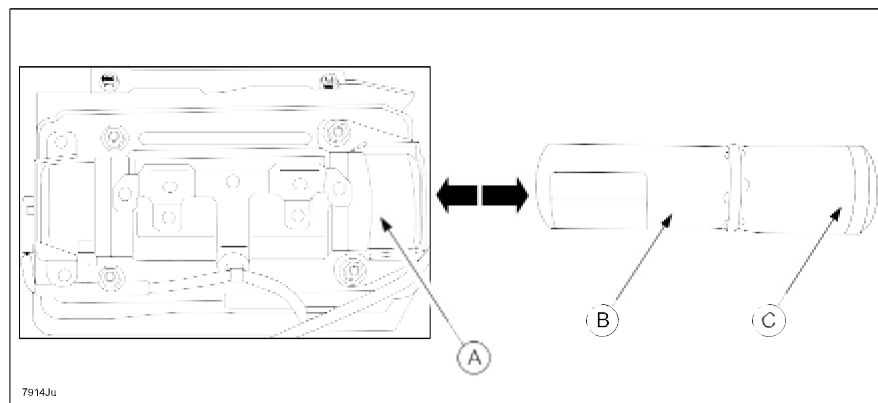

2. Pack and return the removed inflator as follows:

**IMPORTANT: Be sure to follow the packing and shipping instructions provided in the carton and in Attachment IV, Air Bag Inflator Return Instructions.**

**CAUTION:**

- Use the same carton which was used to deliver a new inflator. It is a specialized box that is internationally accepted for shipping an inflator.
- Pack the old inflator in the box exactly in the same manner as the new inflator was packed.

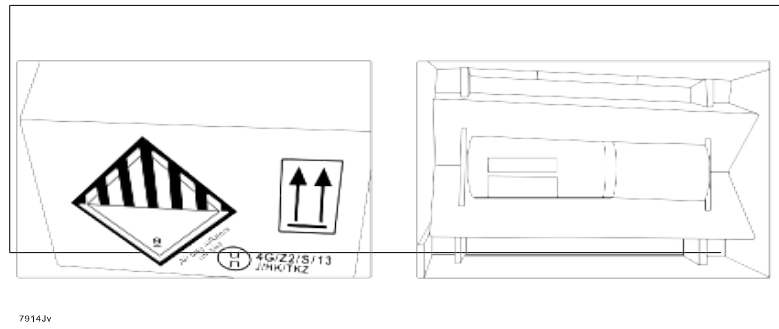

### Air Bag Module Removal:

#### WARNING:

- Perform the replacement in a clean environmental. Oil, grease, water, etc. on components may cause the air bag modules to fail to deploy in an accident, which may cause serious injury. Do not allow oil, grease, water, etc., on components.
- Inserting a screwdriver, etc., into the connector of an air bag module may damage the connector and cause the air bag module to deploy improperly, which may cause serious injury. Do not insert any foreign objects into the connector.
- Do not disassemble the vehicle, other than instructed here.
- Do not make an attempt to directly supply electrical power to the module and the inflator.
- Keep the module facing upwards at all times, except during replacement.
- Do not use the module and new inflator if they were dropped on the ground.
- Avoid module and inflator exposure to temperatures of 194 degrees F (90 degrees C) or more.

1. Turn the ignition switch to the LOCK position.
2. Record the customer's preset radio stations.
3. Disconnect the negative battery cable and wait for one (1) minute or more.
4. Remove the glove compartment.
  - a. Bend the stoppers inward (A), then remove.

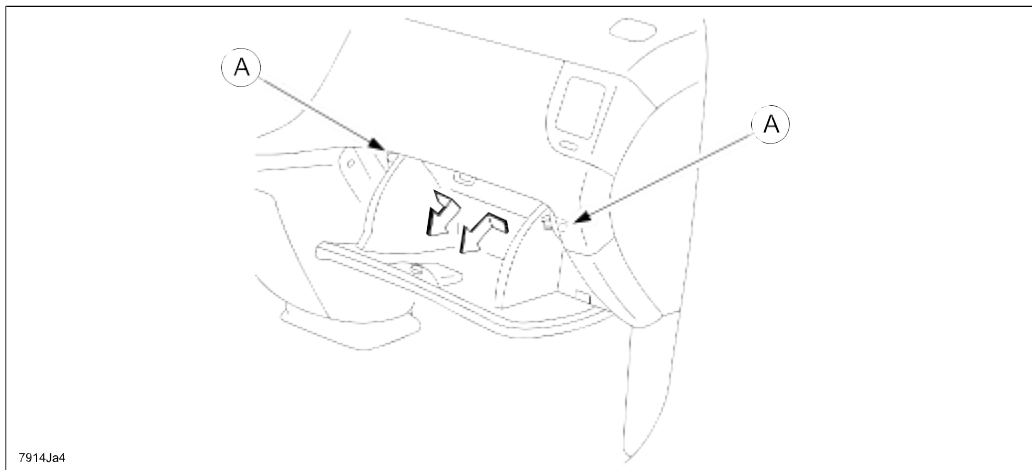

- b. Pull the glove compartment toward you while pushing it downward (1), then remove clip (A).
- c. Slide the glove compartment toward driver's side door (2).

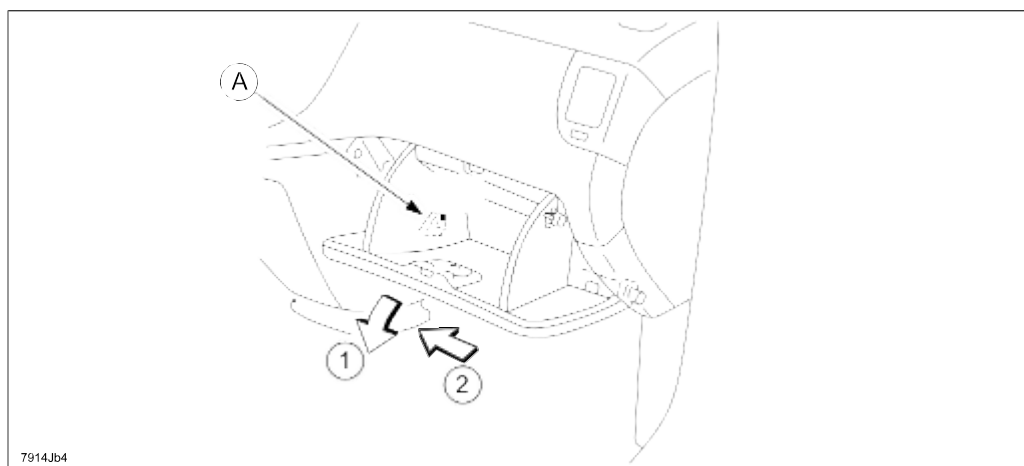



5. Remove the air bag module (A).
  - a. Disconnect the connector (B).
  - b. Remove the bolts (C).

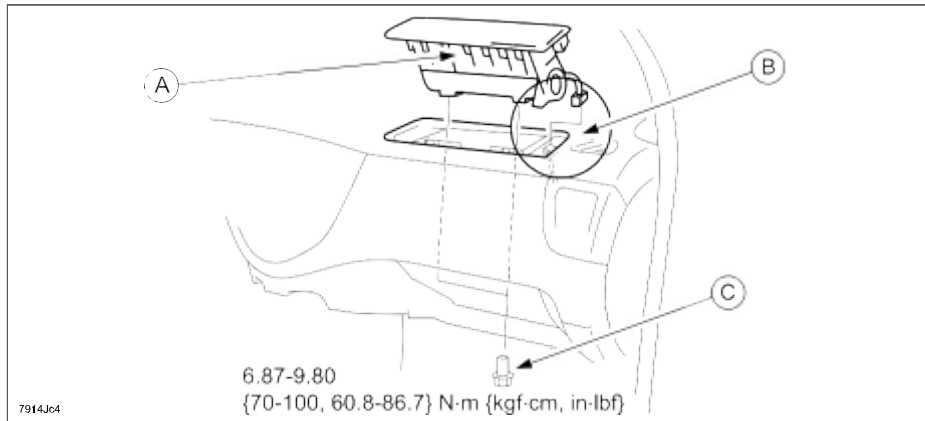

6. Lay a protective cloth on the work bench, then place the air bag module on it to avoid any damage or scratches to the surface.

#### Inflator Replacement:

1. Using a flathead screwdriver, pry out the connector stopper plate (A), then disconnect the connector.

#### CAUTION:

- Be careful when prying out the stopper plate. Otherwise, damage to the stopper plate could occur. The stopper plate must be pried up before disconnecting the connector. Otherwise, the connector could be damaged if trying to disconnect it with the stopper plate engaged.
- Use extreme care when disconnecting the connector. Otherwise, damage to the connector could occur.

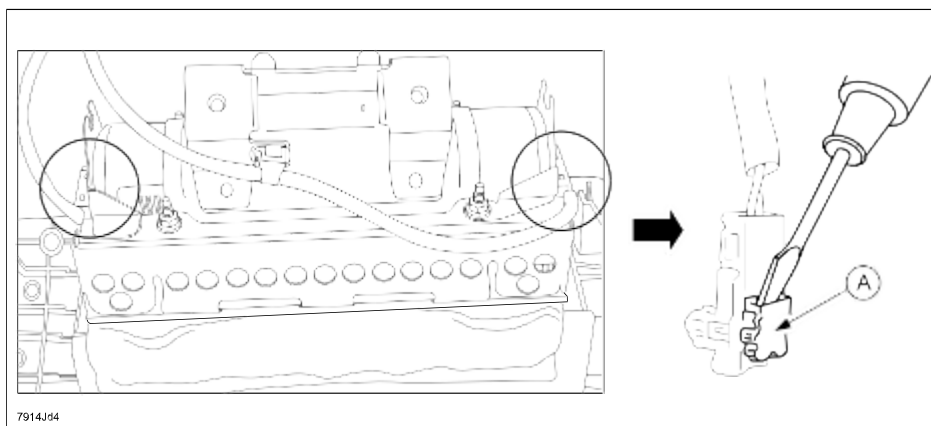

**NOTE:** If a stopper plate (A) is broken, replace the stopper plate with a new one, if applicable. Two types of stopper plates exist - an old type (GAY1-67-022) and a new type (GAY2-67-022). The exact switching date from the old type to the new type is unknown. Confirm the configuration of the stopper plate used on the vehicle in repair, and then use the one with the same configuration.

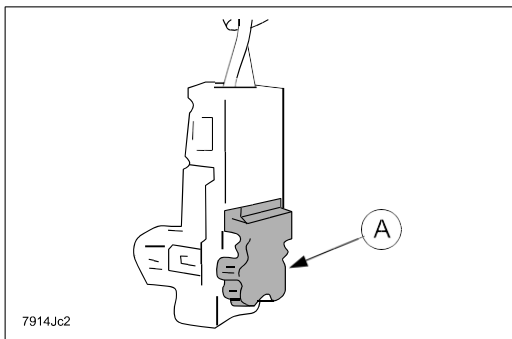

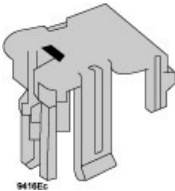
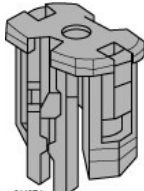
Old Type (GAY1-67-022)	New Type (GAY2-67-022)
 <p>9418Ec</p>	 <p>9418Ed</p>

2. Loosen four (4) nuts until the upper surface of the nuts are aligned with the top edge of the screw thread.
3. For easier inflator removal, depress the four (4) nuts and make a gap between the inflator and air bag module.  
**NOTE:** Do not depress excessively as the module body may detach.

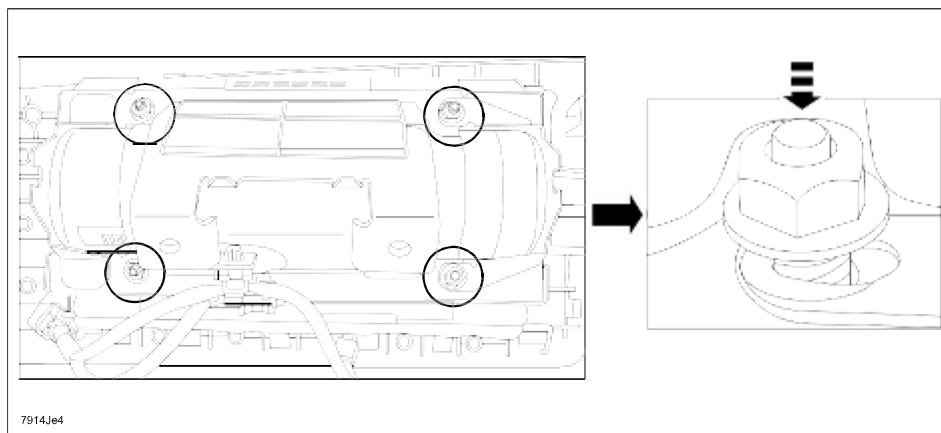

4. Remove the four (4) nuts, then remove the stopper plate from the air bag module.

**NOTE:** Discard all of the nuts and stopper plate.

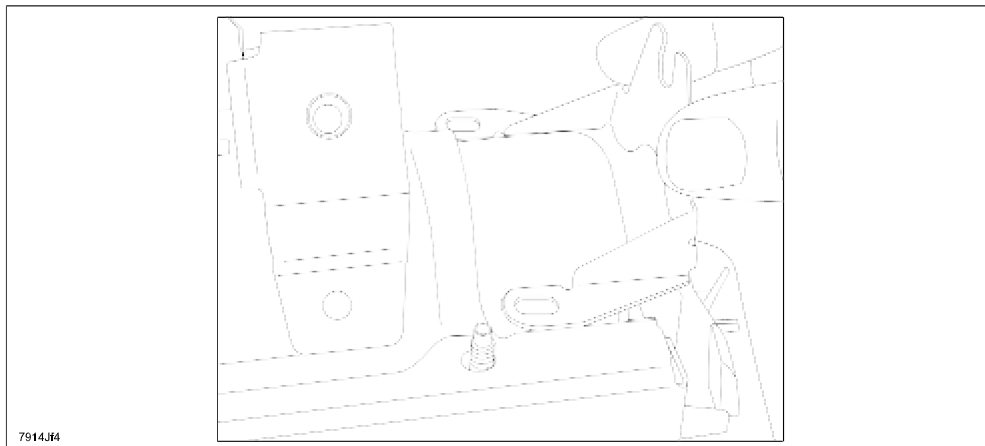

5. Push the inflator end with fingers, then remove it by sliding it in the direction shown.

**IMPORTANT:** Return the removed inflator in the same carton in which the new part was received. Carefully follow the packing and shipping instructions included in the carton.

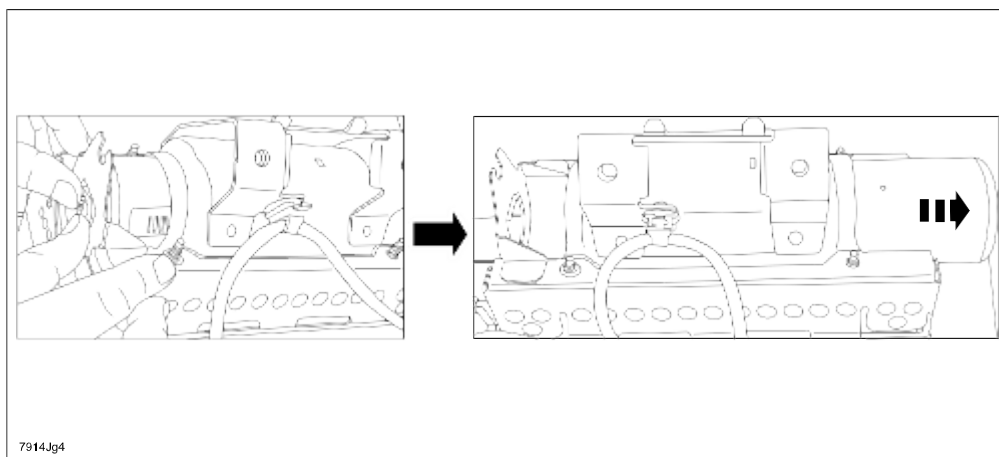

6. Paste the felt tape to Straight area (Orange area) the retainer. (Paste in two places)



Felt tape × 2

Straight area (Orange area)

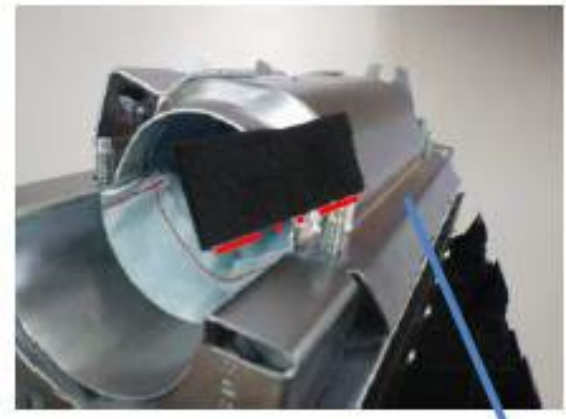
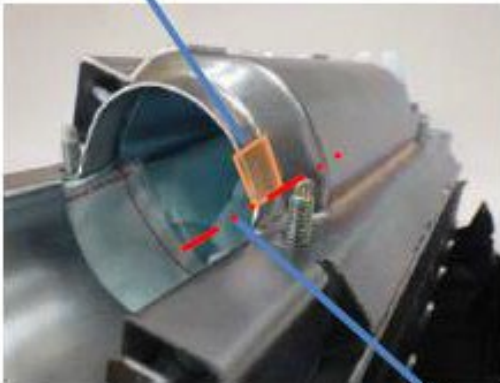

Reference position for pasting Edge of straight area. (Red line)  
※Do not jut out outside the Red line. (bolt side)

7. Fold it in half and paste it inside the retainer. Make it the same on both sides.

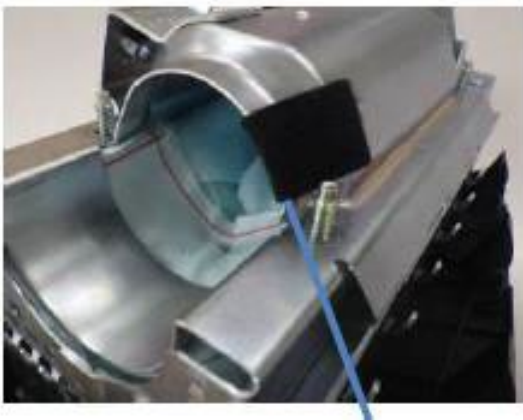

Fold it in half and paste it inside the retainer.



Make it the same on both sides.

8. Attach the collar A and C to replacement inflator.  
(Location of the collar A: The position is the 1st stage side of the inflator.)  
(Location of the collar C: The position is the 2nd stage side of the inflator.)

COLLAR C



COLLAR A



2nd stage  
(Orange connector)



1st stage  
(Yellow connector)

9. Insert to align the side of the retainer and guide line (Black line) of replacement inflator.

Retainer edge



Align guide line (Black line) with retainer edge.

10. Insert the inflator up to the position where it touches the stopper.  
The connector direction is 15 ° from the bottom of the retainer.

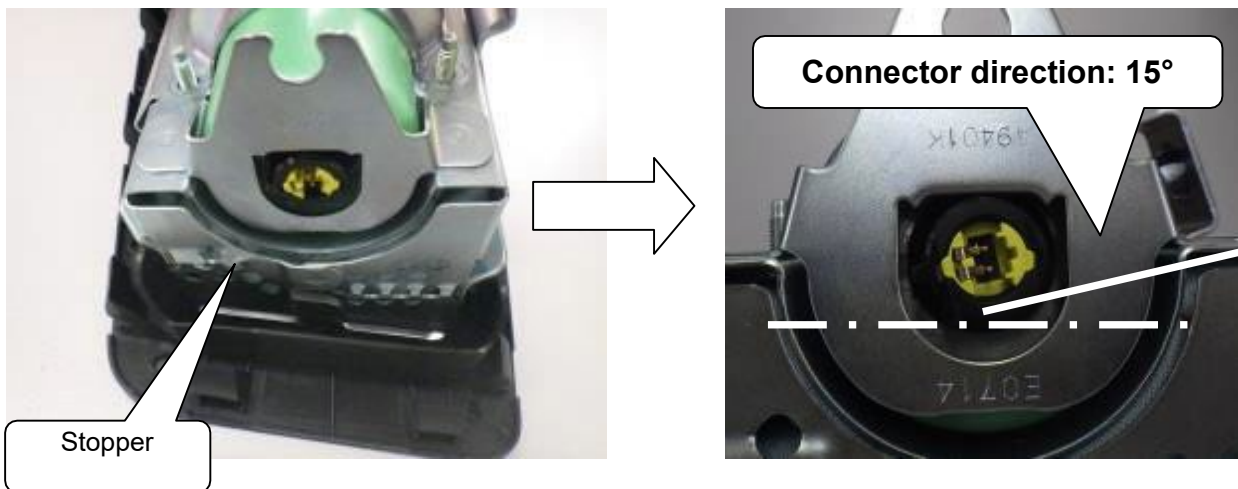

11. Set the new stopper plate (A) by gently pushing until it touches with the inflator side (B).

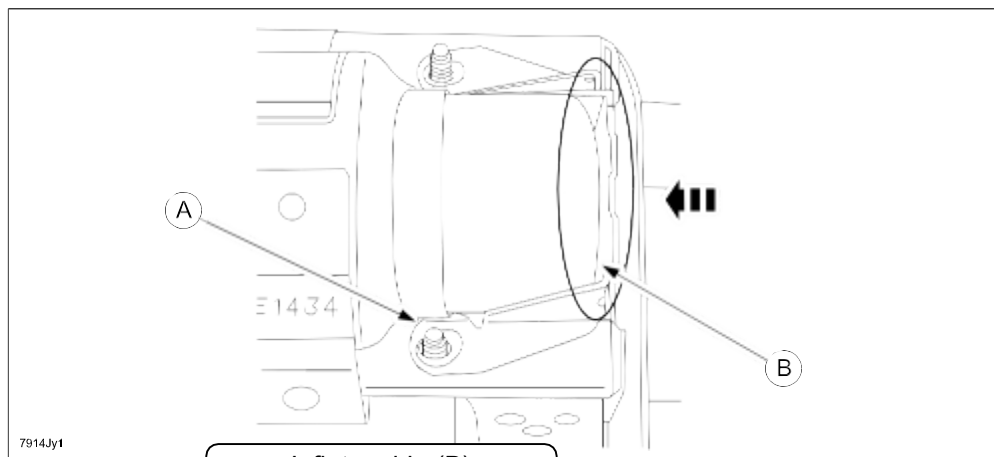

Inflator side (B)

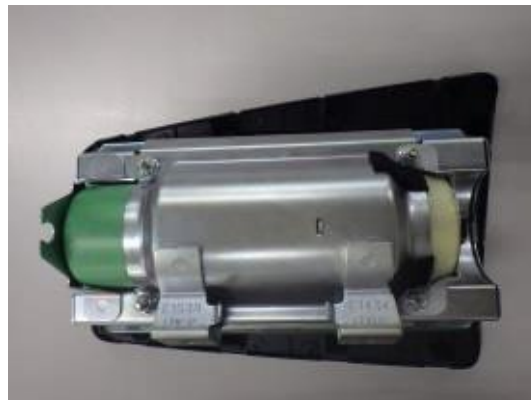
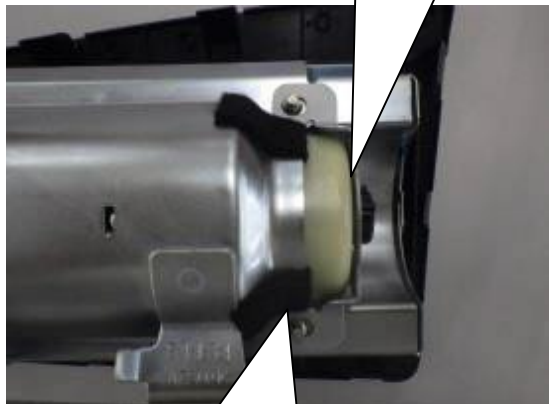

12. Keeping the position above, hand tighten the four (4) new nuts.

13. Tighten the four (4) new nuts to the specified torque in the order shown below (1, 2, 3, 4).

**Tightening Torque: 35 +/- 1.8 in-lbf. {39.8 +/- 2.0 kgf-cm, 3.9 +/- 0.4 Nm} DO NOT USE AIR TOOLS**

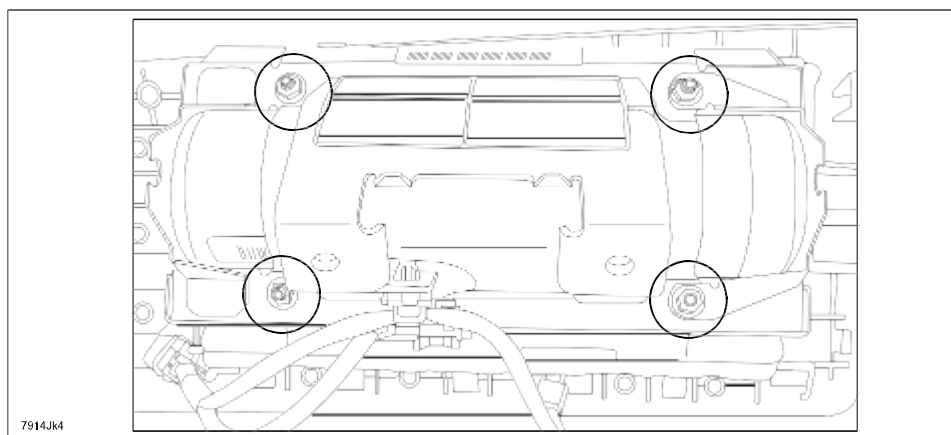

14. Securely lock the connectors by depressing the stoppers on the back of the connector (A).

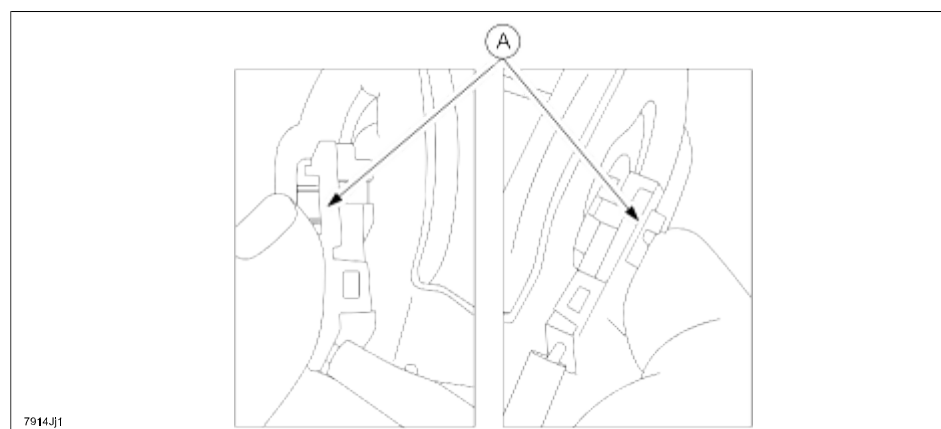

**Air Bag Module Reinstallation:**

1. Re-connect the connector (B), then install the air bag module (A) and the bolt (C).  
**Tightening Torque: 60.8 - 86.7in-lbf. {70 - 100 kgf-cm, 6.8 - 9.8 Nm}**

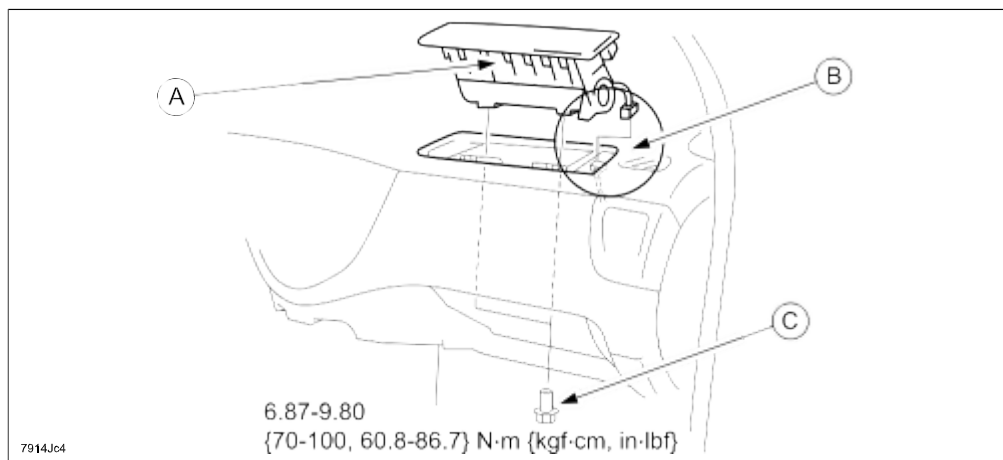

2. Install the connector as shown.

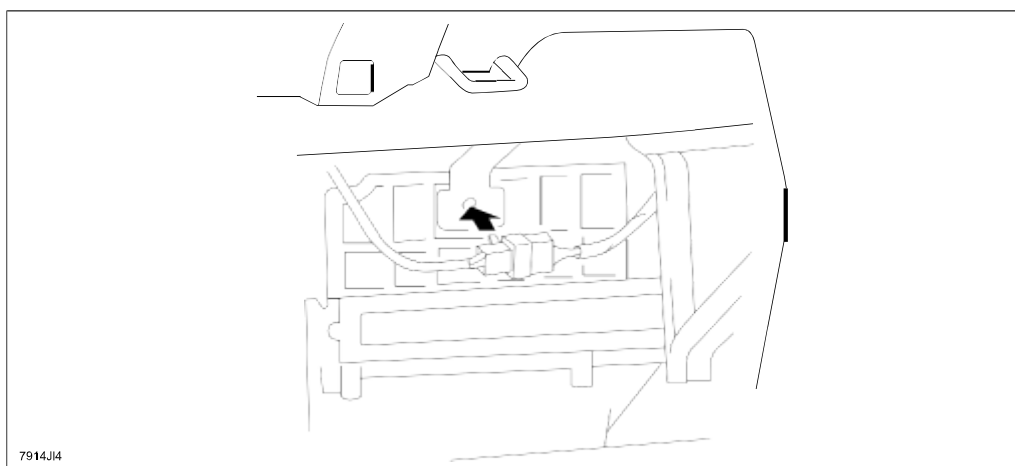

3. Reconnect the negative battery cable.
4. Turn the ignition switch to the ON position.
5. Verify that the air bag system warning light illuminates for approx. 6 sec., then goes out.



**NOTE:** If the air bag system warning light does not operate in the manner described above, there is a malfunction in the system. Inspect the system following the on-board diagnostic system procedure according to MS3 online or the Workshop Manual (section 08 Restraints).

6. Reinstall the glove box.
7. Re-enter the customer's preset radio stations.
8. Proceed to "C. CAMPAIGN LABEL INSTALLATION".

### C. CAMPAIGN LABEL INSTALLATION

1. Fill out a blue "Campaign Label" (9999-95-065A-06) with Campaign No: "2618F", your dealer code, today's date.

CAMPAIGN LABEL	
CAMPAIGN NO:	_____
DEALER CODE:	_____
DATE:	/  /

P/N 9999-95-065A-06

1326b

2. Affix it to the hood or bulkhead as shown:

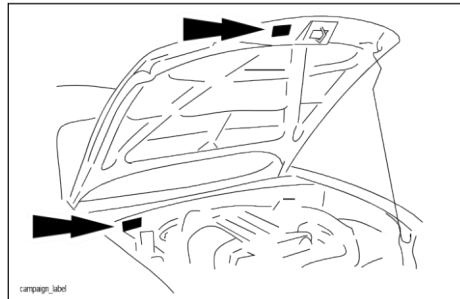

campaign\_label

3. Return the vehicle to customer.