

Compliance Recall

Code: 69W6



Subject	Front Passenger Seat-Mounted Side Airbag (USA ONLY)
Release Date	July 13, 2018
Affected Vehicles	U.S.A.: Certain 2018 MY Audi S5 Cabriolet with Super Sport seats <i>Check Campaigns/Actions screen in Elsa on the day of repair to verify that a VIN qualifies for repair under this action. Elsa is the <u>only</u> valid campaign inquiry & verification source.</i> <ul style="list-style-type: none">✓ Campaign status must show "open."✓ If Elsa shows other open action(s), inform your customer so that the work can also be completed at the same time the vehicle is in the workshop for this campaign.
Problem Description	<p>The seat-mounted head/thorax airbag installed in the front passenger seat may not have been folded according to Audi manufacturing specifications. Because of this, the Out of Position test requirements of the voluntary "Recommended Procedures for Evaluating Occupant Injury Risk from Deploying Side Airbags" may not be met.</p> <p>Affected vehicles still comply with all FMVSS and U.S. NCAP requirements, and all other parts of the "Recommended Procedures for Evaluating Occupant Injury Risk from Deploying Side Airbags" are fulfilled.</p>
Corrective Action	Replace the front passenger seat-mounted side airbag.
Parts Information	Parts will be allocated prior to owner notification. If allocated parts have been used and your dealership is at the weekly Upper Order Limit, please submit the backordered sales document number to upperorderlimits@audi.com to have additional parts released.
Code Visibility	<p>On or about July 13, 2018, affected vehicles will be listed on the Inventory Vehicle Open Campaign Action report under My Dealership Reports (found on www.accessaudi.com & OMD Web). A list will not be posted for dealers who do not have any affected vehicles.</p> <p>On or about July 13, 2018, this campaign code will show open on affected vehicles in Elsa.</p> <p>On or about July 13, 2018, affected vehicles will be identified with this campaign code in the VIN Lookup tool at www.audiusa.com and on the NHTSA VIN lookup tool at www.safercar.gov.</p>
Owner Notification	Owner notification will take place in July 2018. Owner letter examples are included in this bulletin for your reference.
Additional Information	<p>Please alert everyone in your dealership about this action, including Sales, Service, Parts and Accounting personnel. Contact Warranty if you have any questions.</p> <p>IMPORTANT REMINDER ON VEHICLES AFFECTED BY SAFETY & COMPLIANCE RECALLS</p> <p><u>New Vehicles in Dealer Inventory:</u> It is a violation of Federal law for a dealer to deliver a new motor vehicle or any new or used item of motor vehicle equipment (including a tire) covered by this notification under a sale or lease until the defect or noncompliance is remedied. By law, dealers must correct, prior to delivery for sale or lease, any vehicle that fails to comply with an applicable Federal Motor Vehicle Safety Standard or that contains a defect relating to motor vehicle safety.</p> <p><u>Pre-Owned Vehicles in Dealer Inventory:</u> Dealers should not deliver any pre-owned vehicles in their inventory which are involved in a safety or compliance recall until the defect has been remedied.</p> <p>Dealers must ensure that every affected inventory vehicle has this campaign completed <u>before</u> delivery to consumers.</p>

Claim Entry Instructions

After campaign has been completed, enter claim as soon as possible to help prevent work from being duplicated elsewhere. Attach the Elsa screen print showing action open on the day of repair to the repair order.

If customer refused campaign work:

- ✓ U.S. dealers: Submit the request through Audi Warranty Online under the Campaigns/Update option.

Service Number	69W6	
Damage Code	0099	
Parts Vendor Code	002	
Claim Type	Sold vehicle: 7 10 Unsold vehicle: 7 90	
Causal Indicator	Mark Passenger Front Thorax Airbag as causal part*	
Vehicle Wash/Loaner	Do not claim wash/loaner under this action	
Criteria I.D.	F5	
	Replace passenger thorax airbag Labor operation: 6964 19 99 60 T.U.	
	Quantity	Part Number
	1.00	8W7880242E
	1.00	8S0898284
	1.00	N 91191401
		Description
		Passenger Front Thorax Airbag*
		Guide Plate Repair Kit
		Bolt - Airbag to Seat Frame

Customer Letter Example (USA)

<MONTH YEAR>

<CUSTOMER NAME>

<CUSTOMER ADDRESS>

<CUSTOMER CITY STATE ZIPCODE>

This notice applies to your vehicle: <VIN>

NHTSA: 18V325

**Subject: Compliance Recall 69W6 - Front Passenger Seat-Mounted Side Airbag
Certain 2018 Model Year Audi S5 Cabriolet with Super Sport Seats**

Dear Audi Owner,

This notice is sent to you in accordance with the National Traffic and Motor Vehicle Safety Act. Audi has decided that certain 2018 model year Audi S5 Cabriolet vehicles equipped with Super Sport seats vehicles fail to conform to Section 3.3.3.1 in the voluntary commitment to "Recommended procedures for evaluating occupant injury risk from deploying side airbags." Our records show that you are the owner of a vehicle affected by this action.

What is the issue? The seat-mounted head/thorax airbag installed in the front passenger seat may not have been folded according to Audi manufacturing specifications. This may increase the risk of injury to an out of position occupant in a crash with airbag deployment.

What will we do? To correct this noncompliance, your authorized Audi dealer will replace the front passenger seat-mounted side airbag. This work will take about an hour to complete and will be performed for you free of charge. Please keep in mind that your dealer may need additional time for the preparation of the repair, as well as to accommodate their daily workshop schedule.

What should you do? Please contact your authorized Audi dealer without delay to schedule this recall repair. For your convenience, you can also visit www.audiusa.com and click on the "Find a Dealer" link to locate a dealer near you and schedule this service.

Lease vehicles and address changes If you are the lessor and registered owner of the vehicle identified in this action, the law requires you to forward this letter immediately via first-class mail to the lessee within ten (10) days of receipt. If you have changed your address or sold the vehicle, please fill out the enclosed prepaid Owner Reply card and mail it to us so we can update our records.

Can we assist you further? If your authorized Audi dealer fails or is unable to complete this work free of charge within a reasonable time, please contact Audi Customer Experience at 1-800-253-2834 or via our "Contact Us" page at www.audiusa.com.

Checking your vehicle for open Recalls and Service Campaigns To check your vehicle's eligibility for repair under this or any other recall/service campaign, please visit the **Recall/Service Campaign Lookup** tool at www.audiusa.com and enter your Vehicle Identification Number (VIN).

If you still cannot obtain satisfaction, you may file a complaint with: The Administrator, National Highway Traffic Safety Administration, 1200 New Jersey Avenue, SE., Washington, DC 20590; or call the toll-free Vehicle Safety Hotline at 1-888-327-4236 (TTY: 1-800-424-9153); or go to <http://www.safercar.gov>.

We apologize for any inconvenience this matter may cause; however we are taking this action to help ensure your safety and continued satisfaction with your vehicle.

Sincerely,

Audi Customer Protection

NOTE



Damages resulting from improper repair or failure to follow these work instructions are the dealer's responsibility and are not eligible for reimbursement under this action.

Required Parts

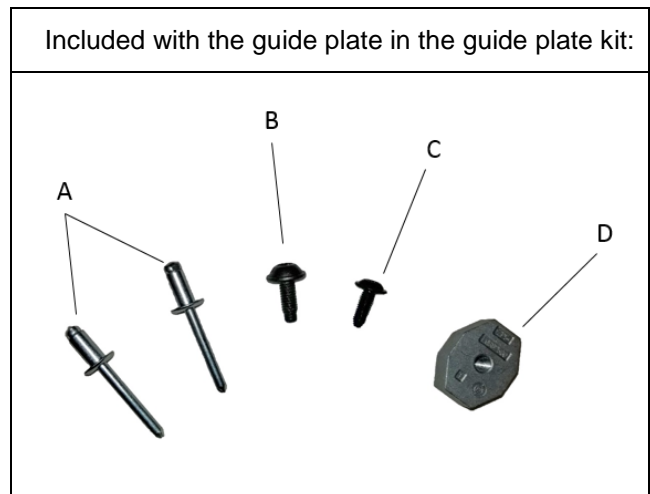
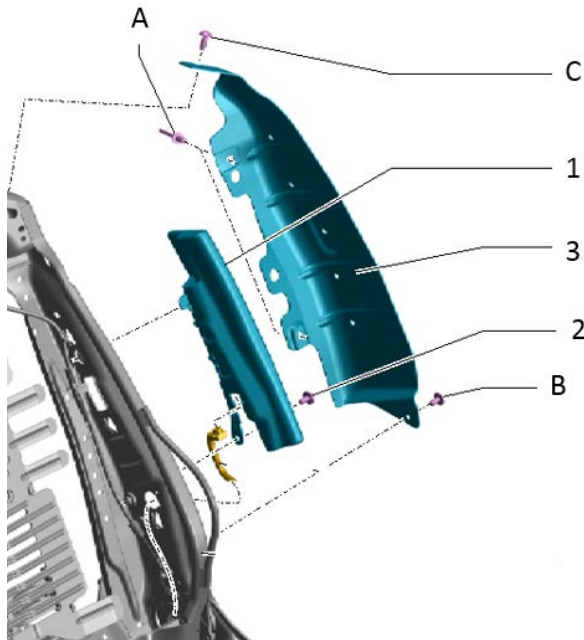
<u>Criteria</u>	<u>Quantity</u>	<u>Part Number</u>	<u>Part Description</u>	<u>Position</u>
F5	1	8W7880242E	Passenger Front Thorax Airbag	1
	1	N 91191401	Bolt - Airbag to Seat Frame	2
	1	8S0898284	Guide Plate Repair Kit:	
			o Guide Plate	3
			o Rivet	A
			o M6 Bolt	B
			o M5 Bolt	C
		o Nut (D)	Not Used	



Required Tools

 <p>Pop Rivet Pliers -VAG1753B- (or equivalent)</p>	 <p>Wedge Set -T10383- (or equivalent)</p>
--	--

Repair Instruction

Section A - Check for Previous Repair

Applicable criteria ID(s)	Campaign/Action Status
01 ← 2	Open ← 1
EXAMPLE	

- Enter the VIN in Elsa and proceed to the "Campaign/Action" screen.

i TIP

On the date of repair, print this screen and keep a copy with the repair order.

- Confirm the Campaign/Action is open <arrow 1>. If the status is closed, no further work is required.
- Note the Applicable Criteria ID <arrow 2> for use in determining the correct work to be done and corresponding parts associated.

Proceed to Section B

Section B – Repair Procedure

⚠ WARNING

Risk of injury. Refer to “Warning and Safety Precautions”, found in **Appendix A** at the end of this document.

! NOTE

- Damages resulting from improper repair or failure to follow these work instructions are the dealer's responsibility and are not eligible for reimbursement under this action.
- This procedure must be read in its entirety prior to performing the repair.
- Due to variations in vehicle equipment and options, the steps/illustrations in this work procedure may not identically match all affected vehicles.
- Diagnosis and repair of pre-existing conditions in the vehicle are not covered under this action.
- When working during extreme temperatures, it is recommended that the vehicle be allowed to acclimate inside the shop to avoid temperature-related component damage/breakage.

- Position the passenger front seat all the way forward.

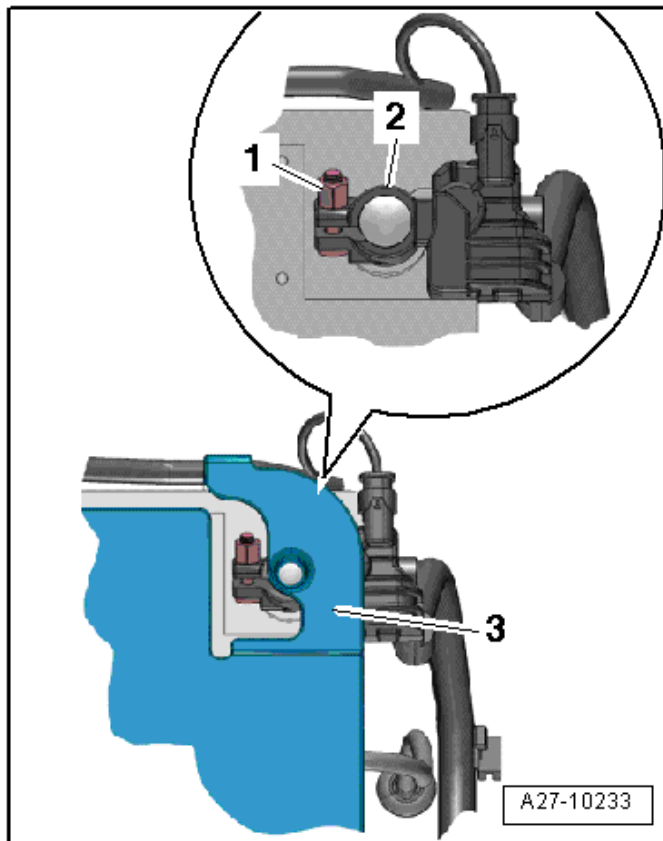

⚠ WARNING

Accident risk. When working on pyrotechnic components (such as airbags and belt tensioners), the battery must be disconnected with the ignition switched **ON**.

- Turn the ignition **ON**.
- If equipped, reposition or remove the vehicle tool kit.
- Open the cover <3> over the battery negative terminal.
- Loosen the nut <1>.
- Remove and isolate the battery ground cable terminal from the battery pole.

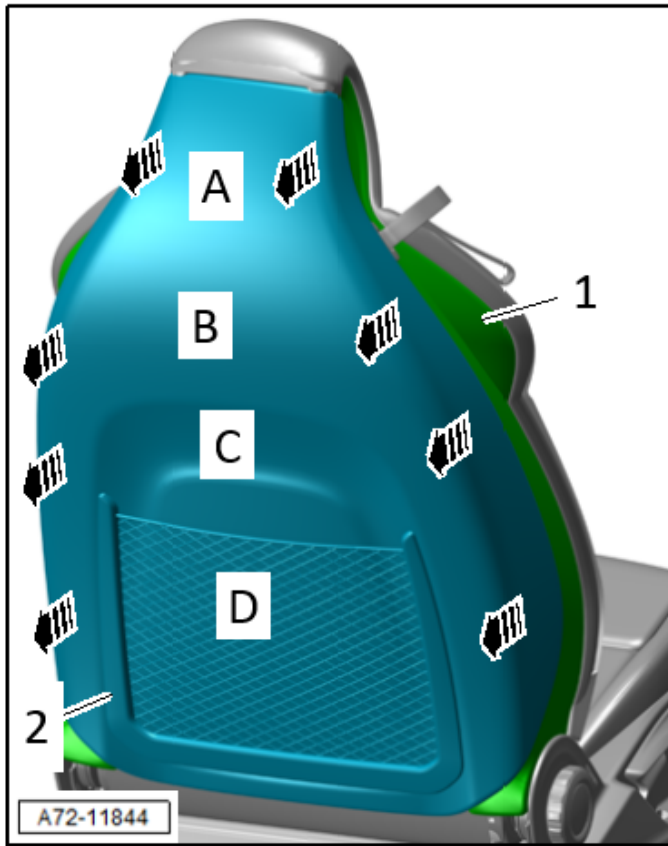

- Remove the backrest cover <2>:
 - Hold the side trim <1> in place while removing backrest cover in direction of <arrows>.
 - Start at the top <arrow A> and work down to <arrow D>.
 - If necessary, use the Wedge Set -T10383- to aid in loosening the catches.

CAUTION

The side trim can be damaged relatively easily. Counterhold side trim <1> when removing and installing the backrest cover <2>.

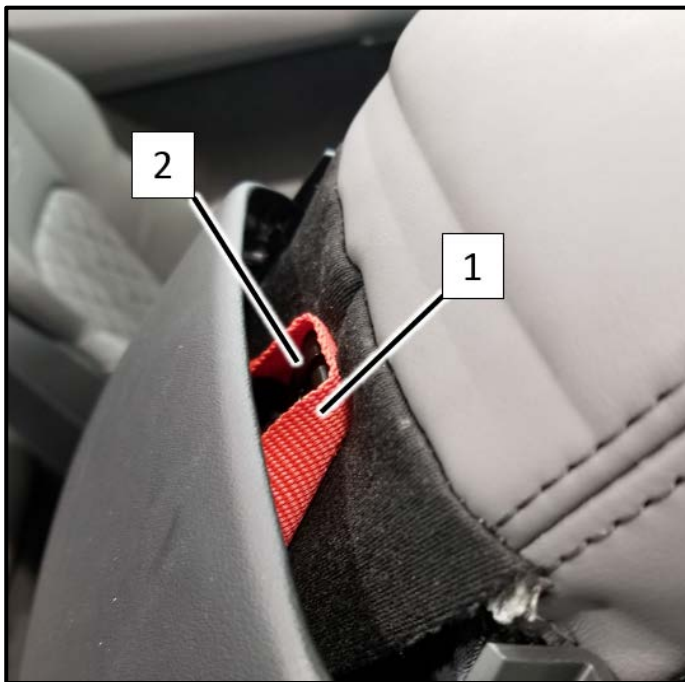

- Guide the backrest safety strap <1> up and out of bracket <2>.

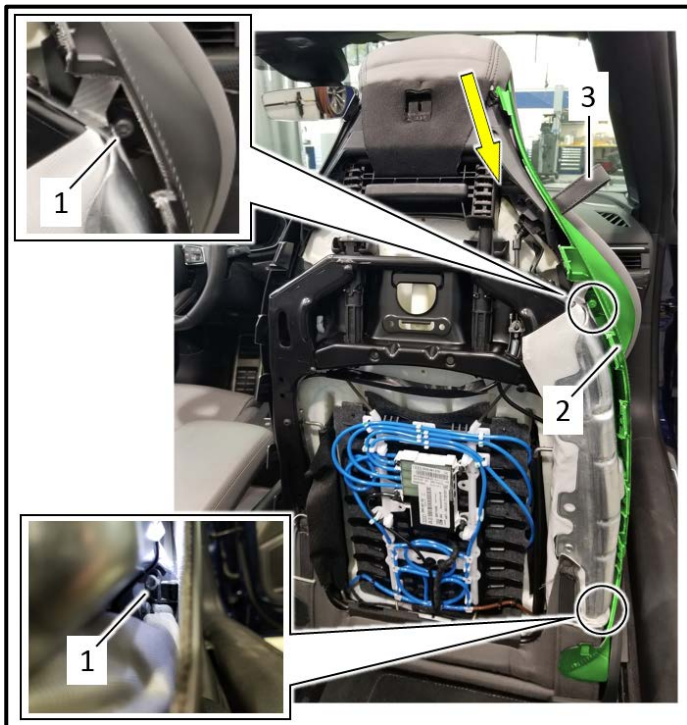

- Remove the side trim:
 - Remove bolts <1>.
 - Remove the side trim <2> downward from the side bolster in direction of <arrow> and remove.
 - Disconnect connector.
 - Guide seat release strap <3> out of the opening in the side trim.

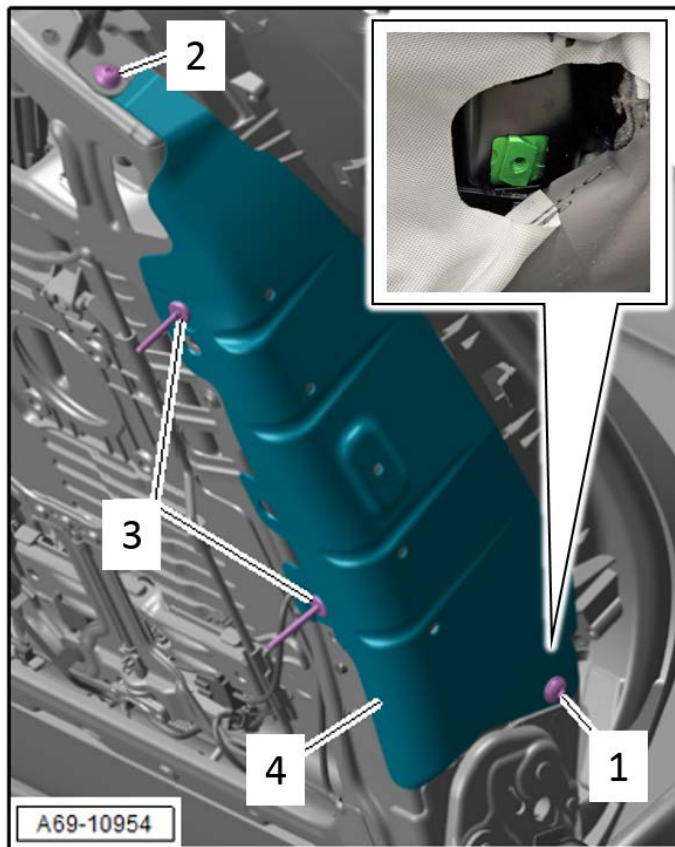

- Remove guide plate <4>:
 - Remove and discard bolts <1 and 2>.
 - Drill out rivets <3>.

NOTE

When drilling out rivets, note the following:

- Place shop rags over the floor and rear seat to catch any metal shavings.
- Max diameter drill bit = 6mm.
- Any large pieces that fall into the seat should be removed with a magnet.
- Any metal shavings remaining should be vacuumed.

TIP

The threaded bushing <inset> for bolt <1> is loose in the seat frame. Avoid pushing the threaded bushing into the seat frame as it will be difficult to reposition.

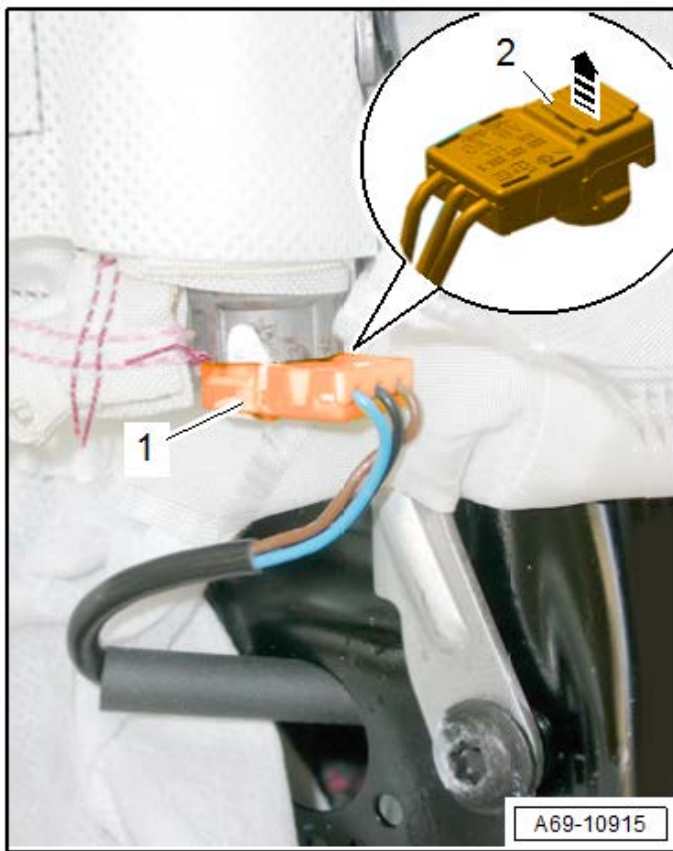

⚠ WARNING

Before handling pyrotechnic components (for example, disconnecting the connector), the person handling it must “discharge static electricity”. This can be done by touching the door striker, for example.

- Release the connector lock <2> with a small screwdriver <arrow>.
- Disconnect the connector <1> on the thorax airbag igniter.

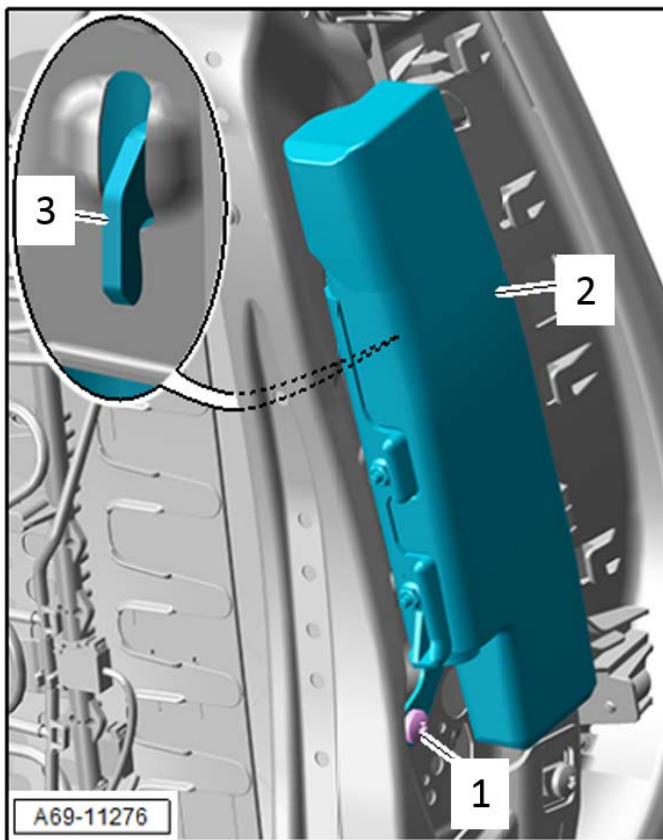

- Remove and discard bolt <1>.
- Lift the thorax airbag <2> so hook <3> disengages from the seat frame.

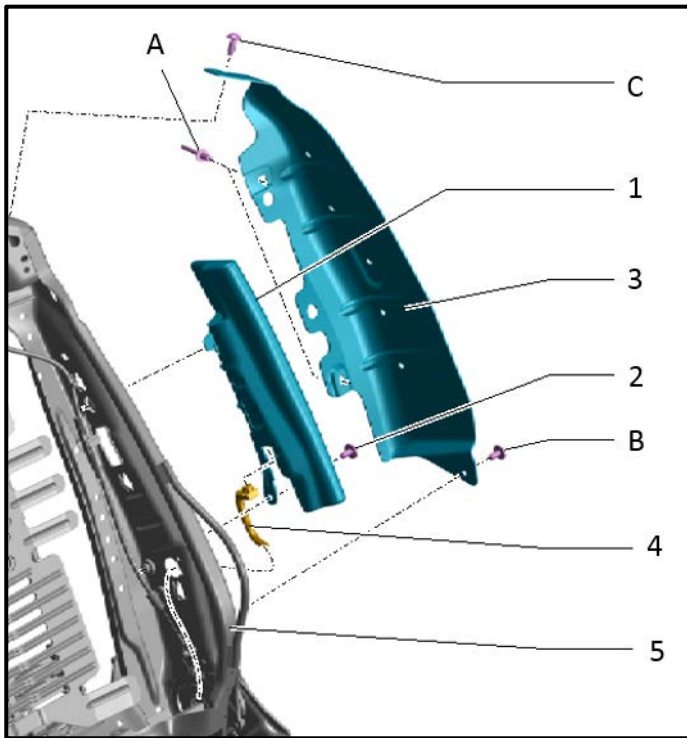

- Install new thorax airbag <1> and torque new bolt <2> to 8 Nm.
 - Ensure the hook on the airbag engages on the seat frame.
- Reconnect connector <4> and engage connector lock.
- Install guide plate <3> with new hardware from the guide plate kit:
 - Torque M6 bolt to 6.5 Nm.
 - Torque M5 bolt <C> to 5 Nm.
 - Install rivets <A> using Pop Rivet Pliers -VAG1753B-.

Part Number	Part Description
8W7880242E	Passenger Front Thorax Airbag
N 91191401	Bolt - Airbag to Seat Frame
8S0898284	Guide Plate Repair Kit

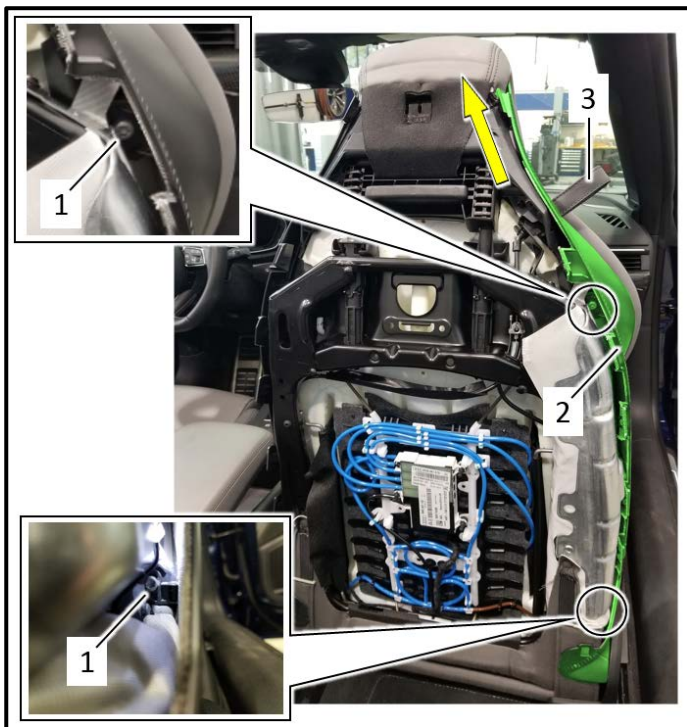

- Install side trim <2>:
 - Guide the seat release strap <3> through the side trim.
 - Connect the connector.
 - Slide the top of the side trim into the seat in direction of <arrow>.
 - Install bolts <1> and torque to 6.5 Nm.

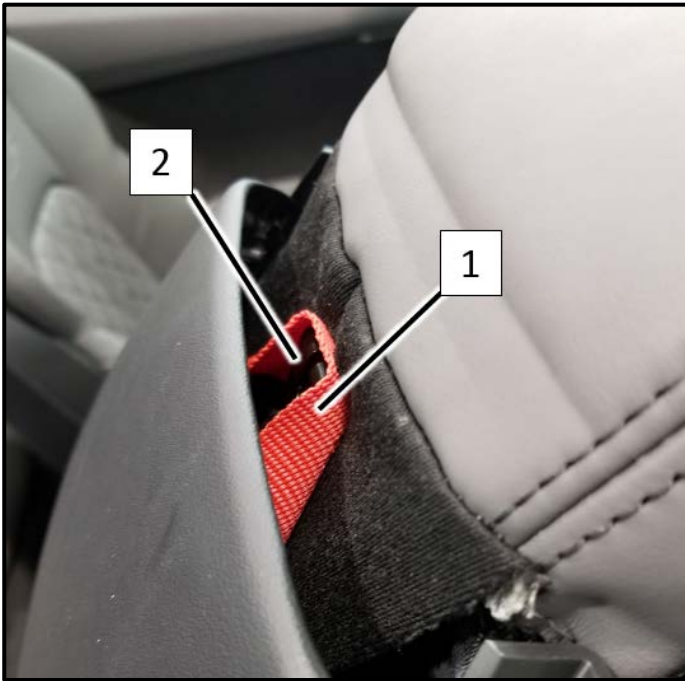

- Guide the backrest safety strap <1> into bracket <2>.

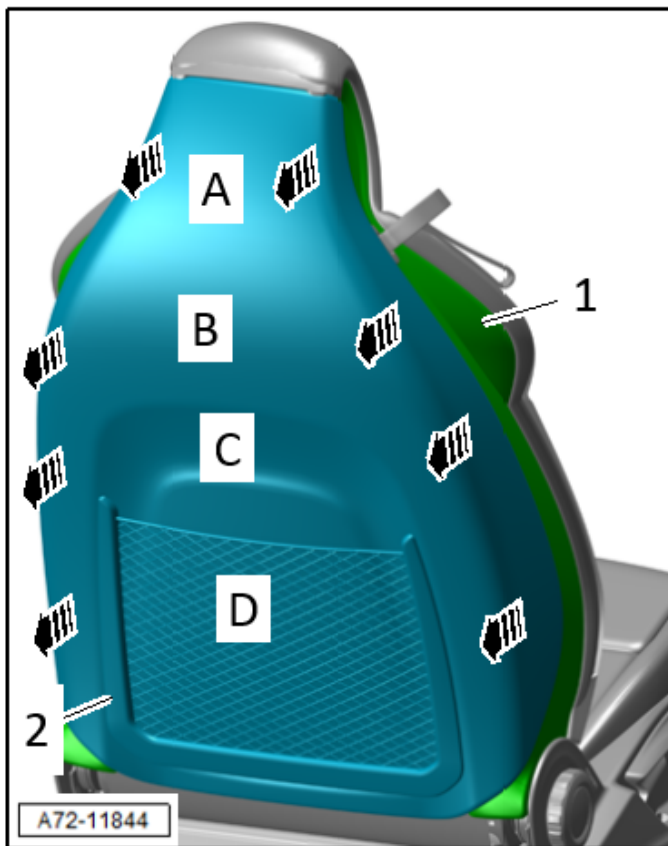

- Install the backrest cover <2> in opposite direction of <arrows D through A>:
 - Install the bottom hooks over the backrest frame.
 - Starting from the bottom <arrow D>, engage the locking tabs on either side of the backrest cover into the side trim <1> on both sides of the seat.
 - Continue engaging locking tabs from <arrow C> to <arrow A>.

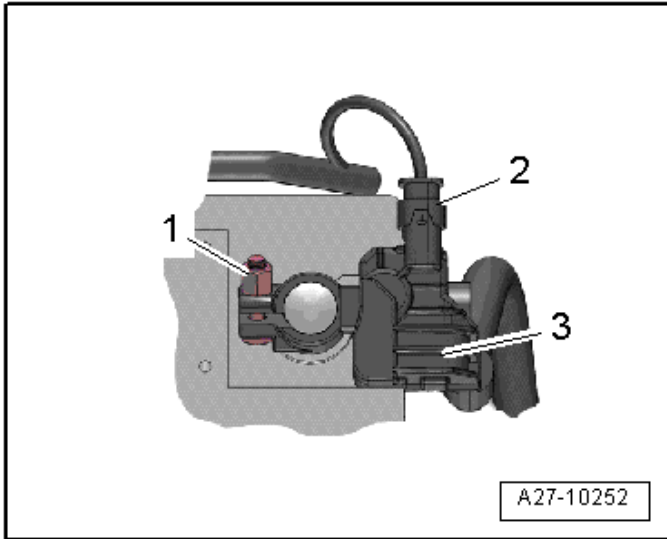

⚠ WARNING

Ignition must be **ON** when connecting battery. If pyrotechnic components (e.g. airbag, belt tensioner) are not repaired correctly, they may deploy unintentionally after connecting the battery. There must not be anyone inside the vehicle when connecting the battery.

- Disconnect the connector <2> from the Battery Monitoring Control Module -J367- <3>.
- Attach the battery ground cable clamp by hand to the battery negative terminal and torque the nut <1> to 6 Nm.
- Reconnect the connector to the Battery Monitoring Control Module -J367-.
- If equipped, install the vehicle tool kit.
- Cycle the ignition off and back on.
- Set clock to local time (if necessary).
- Activate the convenience one-touch open/close functions.
- Check the DTC memories of all the control units and erase under-voltage faults if necessary.

Proceed to Section C.

Section C – Campaign Completion Stamp

I certify that this campaign
has been performed in strict
accordance with the applicable
Audi repair procedure.

SAGA Code: _____
Technician: _____
Date: _____

Item#: AUD4927ENG

-OR-

Je certifie que cette
campagne de rappel a été
exécutée suivant les strictes
directives de réparation
d'Audi

Code de SAGA: _____
Technicien: _____
Date: _____

Item # AUD4927FRE

- Once the campaign has been completed, the technician should stamp the repair order.
- Stamps are available for ordering through the Compliance Label Ordering Portal.
- **Proceed to Section D.**

Section D - Parts Return/Disposal

Properly store (retain), destroy or dispose of removed parts in accordance with all state/province and local requirements, unless otherwise indicated and/or requested through the Warranty Parts Portal (WPP) for U.S. and the Part Destruction and Core Disposition Report for Canada.

Appendix A – Warning and Safety Precautions

WARNING

General Safety Precautions when Working with Pyrotechnic Components:

- Pyrotechnic components always contain propellant that generates a gas during combustion. In some components, there is also a supply of pressurized gas to ensure this gas is generated
- This pressurized gas is stored under high pressure in a compressed gas container. Pyrotechnic components are triggered by electrical/mechanical igniters.
- Only trained personnel should perform testing, assembly and servicing work. Airbags do not have a replacement interval.
- Never check with test lamps, voltmeter or ohmmeters.
- Only check pyrotechnic components when they are installed in the vehicle using vehicle diagnosis, testing and information systems approved by the manufacturer.
- When working on pyrotechnic components and the airbag control module, disconnect the battery ground strap while the ignition is switched on. Then cover the negative terminal.
- Wait 10 seconds after disconnecting the battery.
- The ignition must be SWITCHED ON when connecting the battery. There should not be anyone inside the vehicle when doing this.
- Exception: vehicles with batteries in the passenger compartment. In this case, stay outside the range of the airbags and seat belts.
- Wash your hands after touching ignited pyrotechnic components from the restraint system.
- Do not open or repair pyrotechnic components. Use only new components to reduce the risk of injury.
- Do not install pyrotechnic components that have fallen onto a hard surface or show signs of damage.
- Discharge static electricity before handling pyrotechnic components, for example before disconnecting the electrical connector. This can be done by touching grounded metal objects such as the door striker pin.
- Install pyrotechnic components immediately after removing them from their transport packaging. If you must stop working, store the pyrotechnic component in its original transport packaging.
- Do not leave pyrotechnic components lying in the open unattended.
- Do not treat pyrotechnic components with grease, cleaning solutions or similar products.
- Do not expose pyrotechnic components to temperatures above 100 °C, even for brief periods of time.
- People in the immediate vicinity of the workplace must be protected from possible noise and projectiles.
- Pyrotechnic components can trigger unintentionally.
- In the event of deployment:
 - Single-stage inflators: allow airbag to cool down completely. Wait at least 10 minutes before handling.
- Two-stage inflators: wait for second airbag ignition. Allow airbag to cool down completely. Wait at least 10 minutes before handling.