

REFERENCE:	Nova Bus Manuals
SECTION:	05: Axle, central and rear
RS N°:	MQR 7621-1248
EFFECTIVE IN PROD.:	LA34-001 (2017MR)
TC RECALL N°:	TC 2018-257
NHTSA RECALL N°:	NHTSA 18V299

APPLICATION DEADLINE: NA
CLAIM REFERENCE NUMBER: SR-4420

SUBJECT:	Brake caliper recall campaign
JUSTIFICATION:	Increased friction on caliper guide pins due to surface roughness

LEVEL	DESCRIPTION	DIRECT CHARGES		TIME
		LABOUR	MATERIAL	
1	Install a brake caliper rebushing kit or a swing unit	Nova Bus	Nova Bus	3h20min/5h40min *
2	–	–	–	–

* When installing a swing unit (fully built caliper, left N8908326, right N8908325), order two actuator nuts (N8908945) per caliper, use 3h20min
* When removing, rebushing and installing a caliper use 5h40min

MATERIAL

QTY	PART N°	REV.	DESCRIPTION	REPLACES PART N°
LEVEL 1				
1	19513083	–	Pad kit	–
2	N8908324		Bushing kit	
LEVEL 2				
–	–	–	–	–

Materials will be available within 70 days once your order has been placed. To order, please contact Prevost Parts by phone at 1-800-771-6682, by fax at 1-888-668-2555 or by email at prevostparts.commandes@volvo.com. Specify document number, quantity of parts required and shipping address.

DISPOSAL OF PARTS

REMOVED PARTS ARE:	DISCARDED	RETAINED *	* To be reimbursed, the parts must be retained and returned in accordance with the usual warranty procedure.
	–	Yes	

REVISION HISTORY

REV.	DATE	CHANGE DESCRIPTION	WRITTEN BY
NR	2018-07-20	Initial release	Marc Rougeau
R1	2018AU23	Added instructions to steps 1.7, 1.13, 1.15 and 1.19 Added times to the description	Marc Rougeau

CLIENT	ORDER	ROAD NUMBER		VIN (2NVY/4RKY...)		QTY
		FROM	TO	FROM	TO	
Austin - CMTA - Texas	LA18	5151	5158	L82J0H9775770	L82J3H9775777	8
Chicago Transit Authority - CTA - Illinois	L848	8090	8099	L82J0F4500863	L82J1F4500872	11
Chicago Transit Authority - CTA - Illinois	L849	8100	8107	L82J5F4500874	L82J2F4500881	8
Chicago Transit Authority - CTA - Illinois	L849	8109	8110	L82J6F4500883	L82J8F4500884	2
Chicago Transit Authority - CTA - Illinois	L849	8134	8149	L82JXF4500908	L82J1F4500923	16
Chicago Transit Authority - CTA - Illinois	L850	8150	8155	L82J5F4500924	L82J5F4500929	6
Chicago Transit Authority - CTA - Illinois	L850	8157	8176	L82J5F4500931	L82J5F4500950	20
Chicago Transit Authority - CTA - Illinois	L850	8178	8179	L82J1F4501262	L82J1F4501263	2
Chicago Transit Authority - CTA - Illinois	L850	8180	8181	L82J1F4501265	L82J1F4501266	2
Chicago Transit Authority - CTA - Illinois	L850	8182	8183	L82J1F4501268	L82J1F4501269	2
Chicago Transit Authority - CTA - Illinois	L850	8184	8185	L82J1F4501271	L82J1F4501272	2
Chicago Transit Authority - CTA - Illinois	L850	8186	8187	L82J1F4501274	L82J1F4501275	2
Chicago Transit Authority - CTA - Illinois	L850	8188	8189	L82J1F4501277	L82J1F4501278	2
Chicago Transit Authority - CTA - Illinois	L850	8190	8191	L82J1F4501280	L82J1F4501281	2
Chicago Transit Authority - CTA - Illinois	L850	8192	8193	L82J1F4501283	L82J1F4501284	2
Chicago Transit Authority - CTA - Illinois	L850	8194	8194	L82J0G9775007	L82J0G9775007	1
Chicago Transit Authority - CTA - Illinois	L850	8195	8199	L82J4G9775009	L82J6G9775013	5
Chicago Transit Authority - CTA - Illinois	L943	8200	8324	L82JXG9775225	L82J3G9775406	125
Démo US	LA13	—	—	L82J4G9775611	L82J5G9775620	10
Houston - Texas	L951	1915	1915	L82J0G9775203	L82J0G9775203	1
Houston - Texas	L981	1916	1994	L82J8G9775434	L82J4G9775513	79
New York City Transit - New York	L841	8094	8134	L82J2F4500959	L82JXF4501034	41
New York City Transit - New York	L841	8184	8206	L82J1F4501035	L82J0F4501057	23
New York City Transit - New York	L841	8252	8269	L82J2F4501058	L82J2F4501075	18
New York City Transit - New York	L842	8090	8093	L82J4F4501076	L82JXF4501079	4
New York City Transit - New York	L842	8207	8213	L82J6F4501161	L82J7F4501170	7
New York City Transit - New York	L842	8399	8408	L82J6F4501080	L82J2F4501089	10
New York City Transit - New York	L842	8318	8332	L82J9F4501090	L82J7F4501105	15
New York City Transit - New York	L842	8359	8373	L82J9F4501106	L82J3F4501120	15
New York City Transit - New York	L842	8409	8432	L82J5F4501121	L82JXF4501146	24
New York City Transit - New York	L842	8481	8491	L82J1F4501147	L82J8F4501159	11
New York City Transit - New York	L843	8135	8153	L82J5F4501197	L82J9F4501221	19
New York City Transit - New York	L843	8214	8230	L82J9F4501171	L82J1F4501195	17
New York City Transit - New York	L843	8270	8293	L82J0F4501222	L82J7F4501251	24
New York City Transit - New York	L843	8333	8347	L82J9F4501252	L82J1G9775016	15
New York City Transit - New York	L843	8374	8380	L82J3G9775017	L82J9G9775023	7
New York City Transit - New York	L844	8381	8170	L82J0G9775024	L82J0G9775105	82
New York City Transit - New York	L845	8171	8480	L82J2G9775106	L82J6G9775187	82
NFTA - Buffalo, New York	L877	1501	1501	L82K0F4500984	L82K0F4500984	1
NFTA - Buffalo, New York	L897	1502	1520	L82K1F4501223	L82K1G9775008	19
NFTA - Buffalo, New York	L947	1601	1624	L82KXG9775248	L82K3G9775320	24
NFTA - Buffalo, New York	LA24	1701	1716	L82K3H9775822	L82K5H9775837	16
NFTA - Buffalo, New York	LA30	1717	1724	L82J8H9775838	L82J5H9775845	8

CLIENT	ORDER	ROAD NUMBER		VIN (2NVY/4RKY...)		QTY
		FROM	TO	FROM	TO	
San Antonio Texas	L990	-	-	L82K5G9775464	L82K5G9775464	1
San Antonio Texas	LA10	422	446	L82K9G9775628	L82K8G9775653	25
San Antonio Texas	LA22	447	555	L82K8H9775654	L82K0H9775762	109
University of Alabama - Alabama	L902	7030	7030	L82J2F4500993	L82J4F4500994	2
University of Alabama - Alabama	L961	7032	7033	L82J7G9775294	L82J9G9775295	2
University of Alabama - Alabama	LA02	7034	7037	L82J8G9775546	L82JXG9775550	4

**WARNING**

Follow your internal safety procedures.

PROCEDURE

- 1.1. Park the vehicle on level ground and place the transmission in neutral (N).
- 1.2. Place the master control switch and the battery disconnect switch in the off position. Follow your local lock-out procedure (see Figure 1).

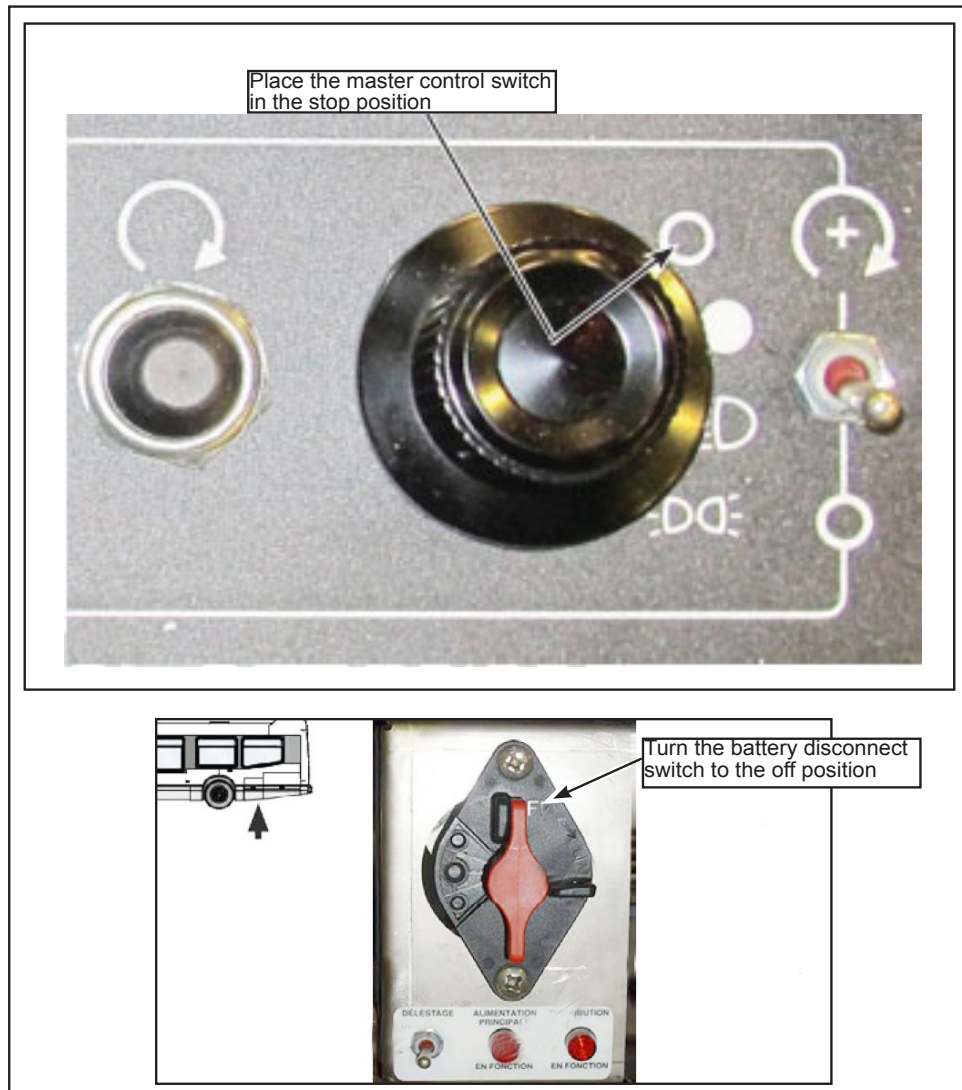

Figure 1 - Place the Master Control Switch and the Battery Disconnect Switch in the Stop Position

**NOTE**

The following procedure is provided by ZF Group and Knorr-Bremse. Nova Bus cannot be held responsible for its content. Contact your service rep for replacement part plan. For caliper replacement omit the rebushing process.

1.3. Knorr brake caliper version SB7 identification (see Figure 2). Documentation of completed service must be logged on affected axle spreadsheet, see annex 1.

- ✓ Caliper identification:
- SB7 (ScheibenBremse)
- ✓ The Knorr type plate includes brake type, Knorr-Bremse part number, axle or vehicle manufacturer's identification number and Knorr-Bremse date of manufacture
- ✓ Radial disc brake SB7 caliper are installed on rear axles (center/drive) with radial mounted service/parking brake chamber

Identification Plate variations

Radial disc brake SB7

Figure 2 - Brake Caliper Identification

1.4. Raise the vehicle according to your maintenance facilities procedures. Secure the vehicle with additional supports at the correct supporting points, see section 18 (Hoisting and Towing) of the maintenance manual (see Figure 3).

T-DRIVE CONFIGURATION

H - HOISTING (REFERS TO RAISING THE BUS USING EQUIPMENT SUCH AS KONI TOWER HOISTS UNDER THE WHEELS/TIRES OF THE BUS)

J - JACKING (REFERS TO LOCATIONS ON THE BUS WHERE A FLOOR OR BOTTLE JACK IS USED TO RAISE THE BUS)

M - MANDATORY SUPPORT POINT FOR SAFETY STANDS

S - SUPPORT POINT FOR SAFETY STANDS

A - ADDITIONAL SUPPORT POINTS FOR SAFETY STANDS

WARNING

Although it is recommended to follow internal, local, state/provincial, and federal regulations when hoisting, Nova Bus advises to use a minimum of four safety stands to support the vehicle. Two stands should be placed behind the rear axle, and two at the front axle.

Figure 3 - Hoisting Points

1.5. Verify and record (see Annex 1) the affected axle serial no. on the type plate (see Figure 4).

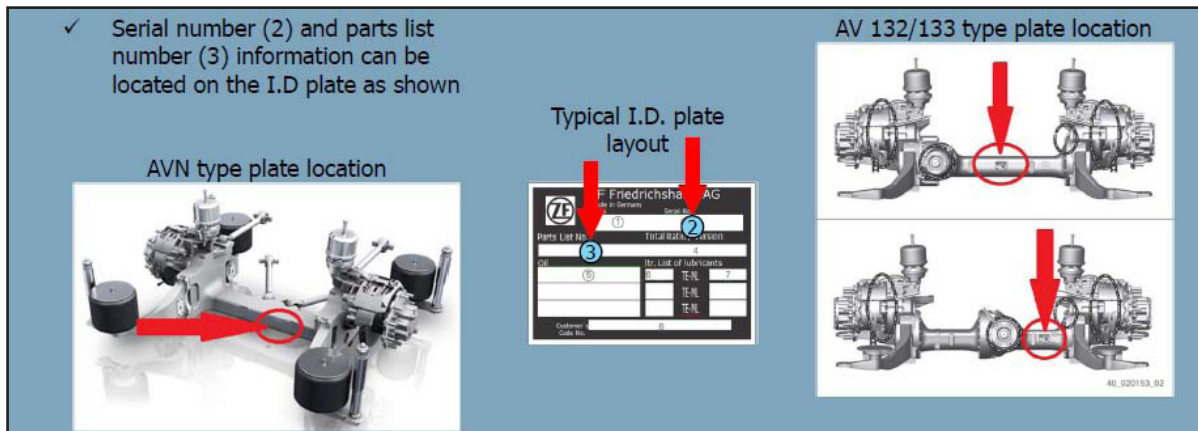

Figure 4 - Axle Serial no.

1.6. Remove the left and right wheels (see Figure 5).

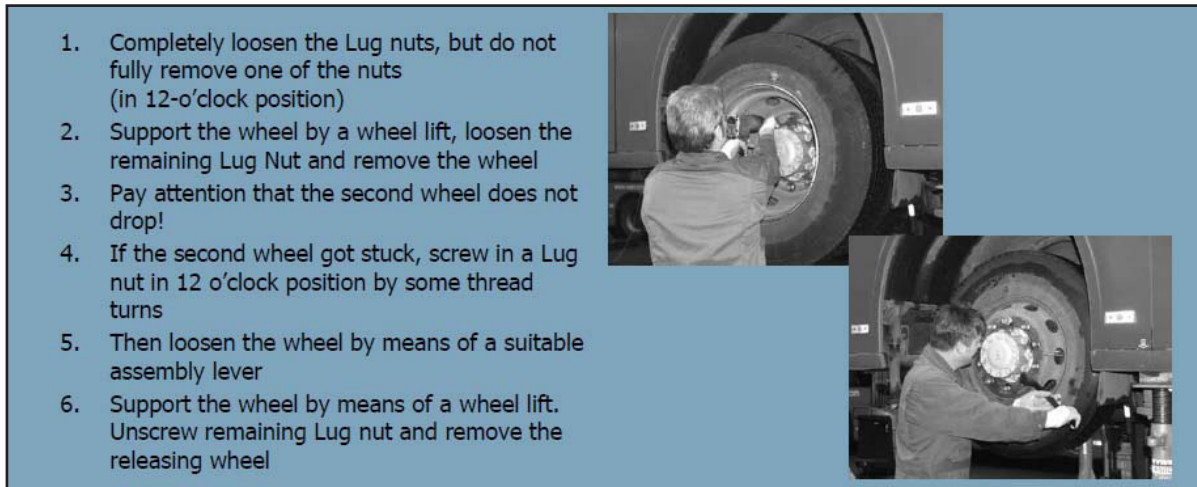

Figure 5 - Wheel Removal

1.7. Verify and record (see Annex 1) the Knorr brake caliper production no.. If the production date code is out of range or if the caliper type plate is already punched, no further action is required (see Figure 6). Indicate labor time to submit a claim.

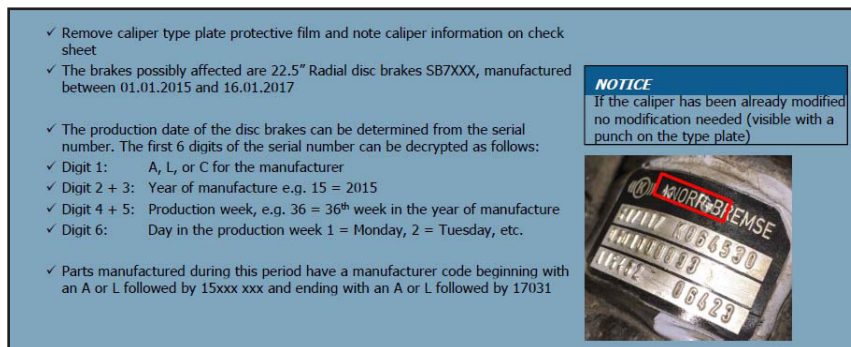



Figure 6 - Brake Caliper Production no.

1.8. Collect all relevant data (see Annex 1) (see Figure 7).

- ✓ Please collect all relevant information
- ✓ Requirement is to submit 1 claim per caliper (2 claims per axle)
- ✓ Must provide Knorr caliper type plate information including removed and replacement caliper information (where applicable)
- ✓ Please provide information listed below as well:
 1. Vehicle in service date (provided by depot)
 2. Vehicle fleet number
 3. Chassis no. (VIN number)
 4. Vehicle mileage
 5. Axle part list number
 6. Axle serial number
 7. Date of re-bushing

Typical VIN location



Dash Mileage readout



Figure 7 - Collect Relevant Data

1.9. Removal of the brake chambers left and right side (see Figure 8).

1. Cage the parking brake

Caution!

Ensure that the park brake is engaged and the spring chamber is released by compressed air

Note: Without air-released spring brake, the caging bolt would be highly stressed when backed out
2. Do not use "power tools"!
3. Clean the surrounding of the attachment areas in order to avoid ingress of dirt into the interior of the brake
4. Loosen the locknuts and remove brake chamber
5. Fix brake chamber with suitable aids (e.g. wire, rope) in the wheel house and cover the openings
6. Inspect mounting face on the brake caliper for any signs of moisture (rust) or contamination
7. Protect the mounting face on the brake caliper by an adequate protective cover or cloth

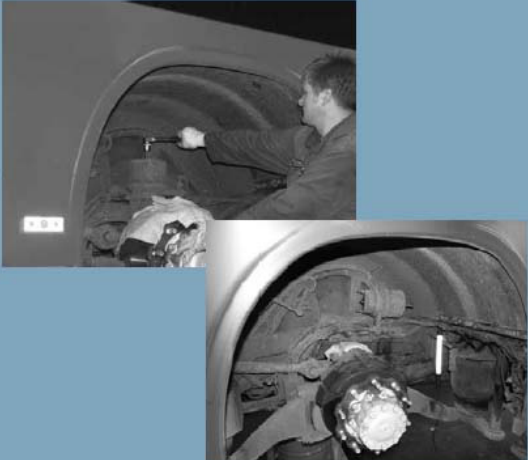



Figure 8 - Removal of Brake Chambers

1.10. Removal of electrical wear sensor connections or potentiometer connections (see Figure 9).

1. Loosen the screws at the potentiometer (wear indicator) and pull off the releasing plug
2. Inspect for any bent pins or corrosion at the plug

Removal of potentiometer screws



Potentiometer location

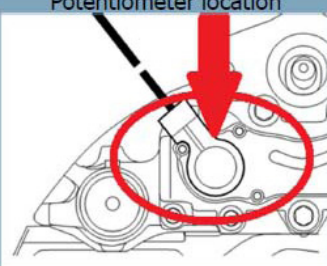

NOTICE

Pad wear may be monitored on certain busses through the dash. If reading is N/A in any position, potentiometer must be tested for correct function

Figure 9 - Removal of Wear Sensor

1.11. Remove the brake pads (see Figure 10).

- ✓ To remove brake pads proceed as follows:
 1. Remove adjuster rubber cap
 2. Turn adjuster (10mm) in counterclockwise direction manually until contact is obtained
 3. Remove spring split pin.
 4. Remove washer and pin
 5. Remove pad retainer bar
 6. Remove brake pads

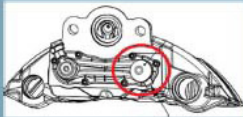

Slack adjuster location



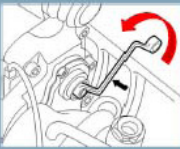

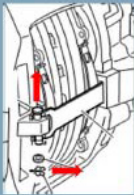

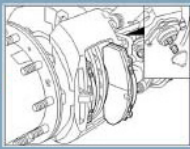

Back off slack adjuster and remove the pad retainer bar in order to remove pads

Figure 10 - Remove the Brake Pads

1.12. Remove the 6 carrier bolts at the center or drive axle (see Figure 11).

- ✓ To remove the caliper and carrier together proceed as follows:
 1. Loosen 6 hexagon bolts and fit bolt on the brake caliper carrier (4 bolts for the front axle)
 2. If the threads of the bolts or the bore is not damaged or corroded, the bolts can be reused (front with Loctite)
 3. Remove brake caliper and carrier from axle

CAUTION

Hold Caliper only at its outer side. Never get your fingers between Caliper and Carrier!

NOTICE

Pay close attention to the position of the fit bolt. Carrier bracket has small recess only in one location for position of the fit bolt

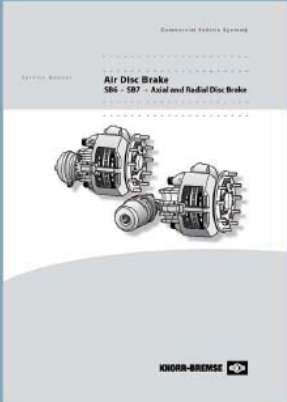

Figure 11 - Remove the 6 Carrier Bolts

1.13. Follow the re-bushing instructions (see Annex A and Figure 12).

- ✓ Follow the re-bushing instructions (Knorr/Bendix repair manual for SB7radial disc brake, mark the type plate accordingly)
- ✓ Paint mark the rebushed caliper with a green visible dot that it has been modified
- ✓ Option: follow the instruction how to change the tappet boots

SB7 Radial Disc Brake Manual



Commercial Vehicle Systems

Air Disc Brake
SB6 - SB7 - Axial and Radial Disc Brake

KNORR-BREMSE

Figure 12 - Rebushing Instructions

1.14. Install the re-bushed or new Knorr brake caliper (see Figure 13).

<ul style="list-style-type: none"> ✓ Place complete re-bushed Knorr caliper/carrier assembly onto the hub carrier ✓ To install SB7 mounting bolts (Qty. 6): 1. Verify the condition of the bolts and thread holes, if not corded or damaged, they can be reused 2. Screw in fit bolt at the front in driving direction and tighten. Torque to 270 Nm 3. Screw in remaining hexagon screws and tighten. Torque to 270 Nm 	<div style="border: 1px solid black; padding: 5px; background-color: #e0e0e0;"> <p>NOTICE</p> <p>Do not torque fit bolt in incorrect position. Damage to bolt and caliper carrier may result.</p> </div>
	

Figure 13 - Install Re-bushed or New Brake Caliper

1.15. Refit the brake chamber, use the new actuator nuts provided in rebushing kits or (N8908945) provided (see Figure 14).

<ul style="list-style-type: none"> ✓ To install brake chamber proceed as follows: 1. Ensure that the spring brake is still released by compressed air 2. Mount brake chamber with the connections in direction as removed 3. Fix brake chamber on brake caliper by means of new locknuts 4. Tightening torque (M16x1.5) MA = 195 ± 15 Nm 5. Release the caging bolt to the brake release position with the tightening torque specified by the manufacturer Note: Different manufacturers may call for different torques and the actuator is not always included in ZF's delivery scope 6. Install the potentiometer (wear indicator) electrical connector and tighten the two screws 	<p style="text-align: center;">Install new locknuts and torque</p> 
---	--

Figure 14 - Install Brake Chamber

1.16. Install brake pads, installing new brake pads (see Figure 15).

<ul style="list-style-type: none"> ✓ To refit brake pads proceed as follows: 1. Install brake pads 2. Install pad retainer bar 3. Install washer and pin 4. Install the shear adapter 5. Turn adjuster (10mm) in clockwise direction manually until contact is obtained. Then back off three clicks to set pad clearance 6. Install protective cap and shear nut 	<p style="text-align: center;">Install brake pads and</p>  <p style="text-align: center;">Adjust pad clearance (back 3 clicks) and install new cap.</p>
---	---

Figure 15 - Install Brake Pads

1.17. Install the wheels (see Figure 16).

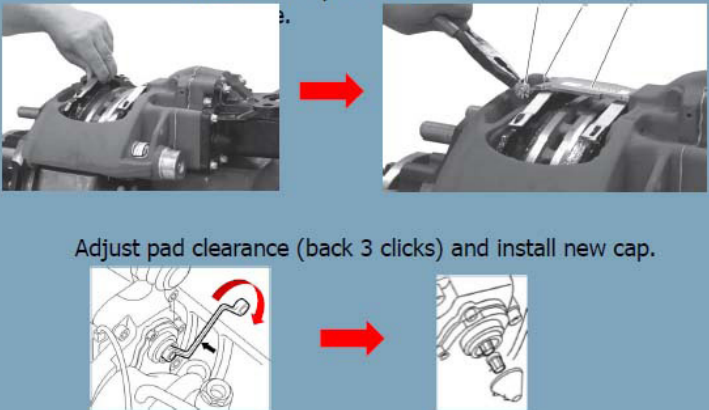
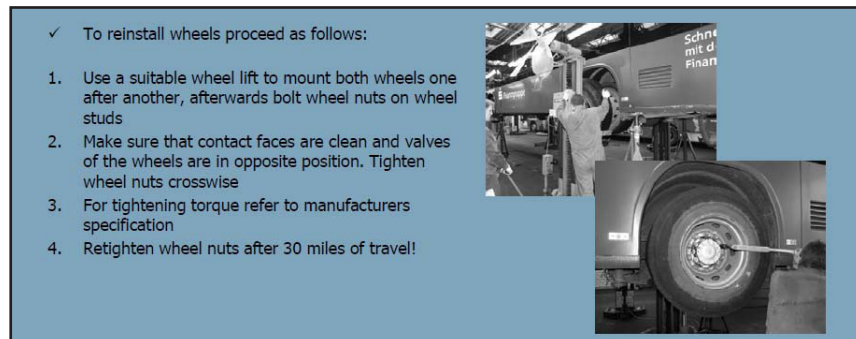

Figure 16 - Install the Wheels

1.18. Deceleration test (see Figure 17).

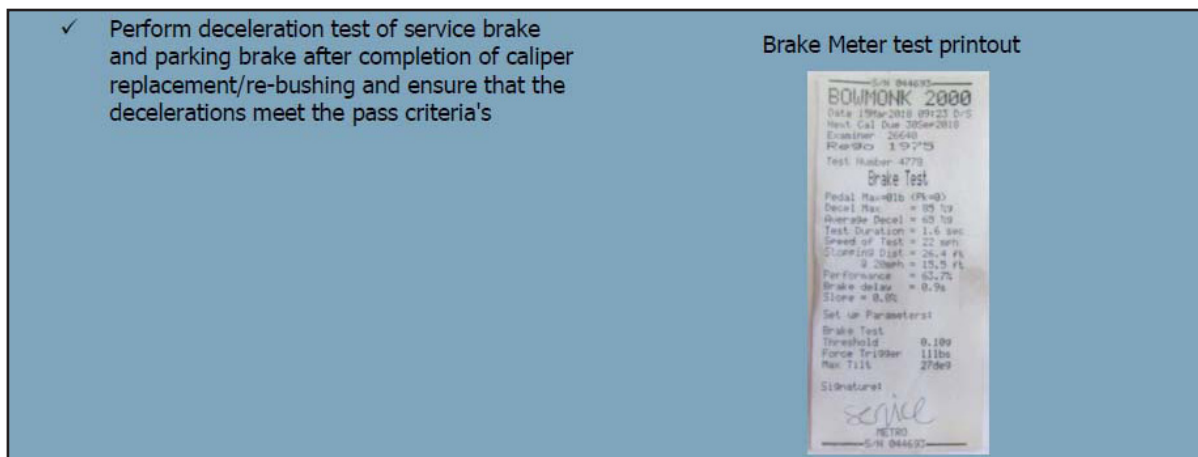

Figure 17 - Deceleration Test

1.19. Send relevant data to ZF via the OEM (see Figure 18). ❖



Figure 18 - Send Relevant Data to ZF

Annex A

Commercial Vehicle Systems

Service Manual

Air Disc Brake
SB6 - SB7 - Axial and Radial Disc Brake

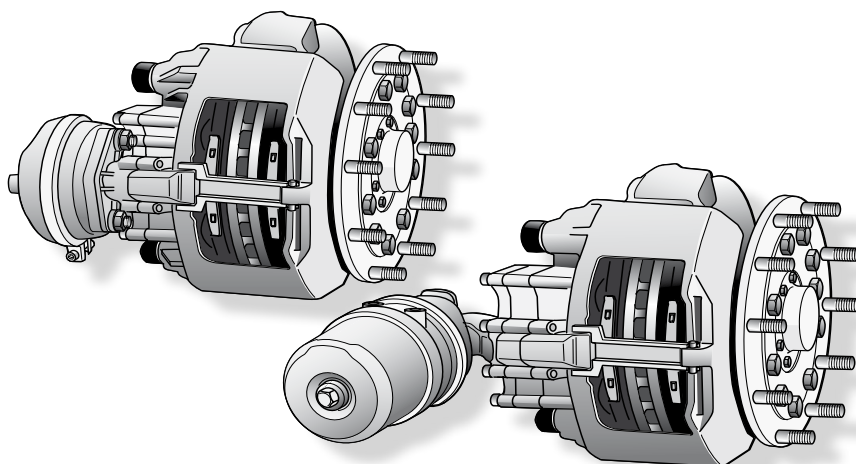

KNORR-BREMSE



10 Guide Pin Bush Replacement
(for Axial and Radial Disc Brakes)

In order to remove and fit Brass Bush (7) use the Pull-in/Pull-out Tool (D) (Part No. II19254).

To groove Brass Bush (7), Grooving Tool (F) (Part No. II36797) must be used.

Remove Caliper (see Section 8.1).

Remove Guide Pin (5 or 5a) and Inner Boot (9) (see Section 9).

10.1 Brass Bush (7) Replacement

Pull out Brass Bush (7) with Tool (D) (Part No. II19254) - see Sketch 1.

If Caliper has a groove (see arrow A):

- Pull in new Brass Bush (7) with Tool (D) - see Sketch 2.
- Remove Tool (D).
- To prevent longitudinal displacement of the new Brass Bush (7) it must be grooved (see arrow B).
- Before insertion of the Grooving Tool (F) (Part No. II36797), its hexagon screw must be wound out so that the head of the screw is approximately 20mm from the tool face.
- Insert the Grooving Tool (F) fully into the Brass Bush (7).
- Wind in the hexagon screw of the Grooving Tool (F) to its stop.
- Slacken the screw and rotate the Grooving Tool (F) in the Brass Bush (7) by approximately 60 degrees.
- Again wind in the hexagon screw of the Grooving Tool (F) to its stop.
- The new Brass Bush (7) is now firmly retained in the Caliper (see arrow B).
- Before removing the Grooving Tool (F), its hexagon screw should be wound out approximately 20 mm.

If Caliper has no groove:

(Note: Groove is always located on the inboard side).

Pull in new Brass Bush (7) with Tool (D) - see Sketch 2.

Check contact area of Brass Bush (7) for burrs and remove any burrs.

Grease Bush with **white** Grease (Part No. II14525 or II32868).

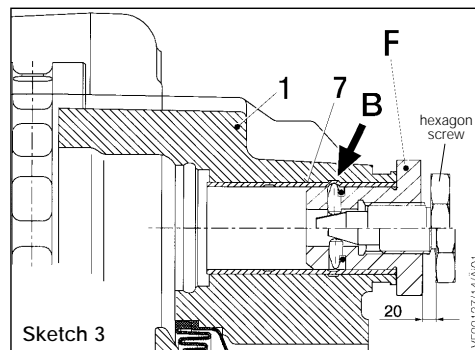
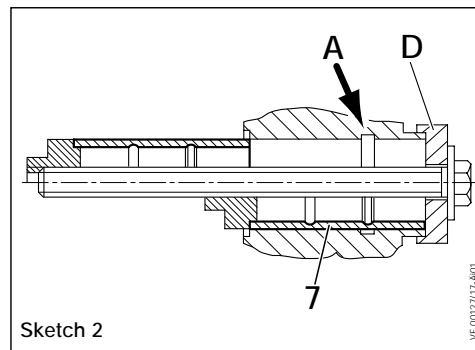
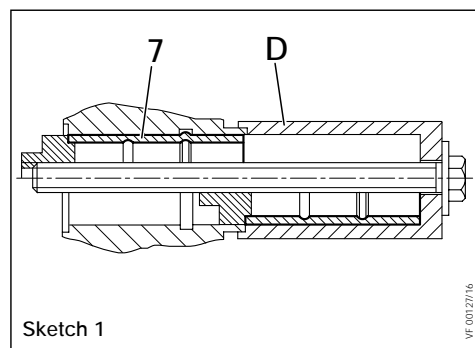
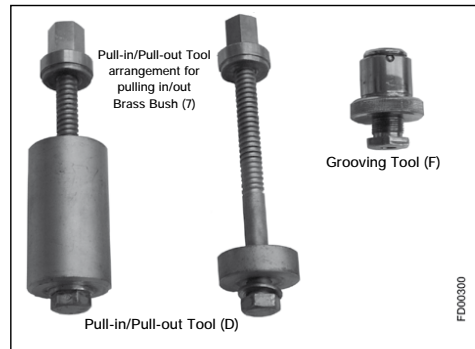

10.2 Rubber Bush (6a or 6b) Replacement

Note:

A short or long version of the Rubber Bush (6a or 6b) is possible. The two versions are not interchangeable - see Sketch 4.

If necessary remove the Caliper (see Section 8.1).

Remove Guide Pin (4a or 4b).

Pull Rubber Bush (6a or 6b) out of bore.
Check bore for corrosion, clean and if necessary use a corrosion protection paint (e.g. Zinc spray).

Note:

Grease new Rubber Bush (6a or 6b) inside and outside with **green** Grease (Part No. I132793 or Z000046).

ATTENTION!
Under no circumstances must the **white** Grease (containing mineral oil) be used for lubricating the Rubber Bush (6a or 6b) and Guide Pin (4a or 4b). Use only synthetic based **green** Grease (Part Number I132793 or Z000046).

Deform new Rubber Bush (6a or 6b) and push from the inside of the Caliper into the bore.

Push Rubber Bush (6a or 6b) so that the external positioning ring(s) locate in the groove(s) (see arrows).

ATTENTION!
The Guide Pins (4 and 5) as well as the Caliper Bolts (39 and 40) are highly stressed items. They must be replaced whenever the Caliper (1) is removed from the Carrier (2).

Assemble Guide Pin (4a or 4b).

Re-fit Caliper (see Section 8.2).

Note:

Torque Caliper Bolts (39a) and (39b) to 180 Nm plus 90°. Check that the Caliper slides easily.

ATTENTION!
Screw threads and tapped holes must be clean and dry (free of lubrication).

10.3 Rubber Bush (6c or 6d) Replacement

If necessary remove Caliper (see Section 8.1).

Use tool (H) (Part No. Z004198) for the assembly of the Rubber Bush (6c or 6d), (see adjacent picture).

Note:

Depending upon shape of the Rubber Bush (6c or 6d) the appropriate disc must be selected, for pressing out (see also Section 10.3.2).

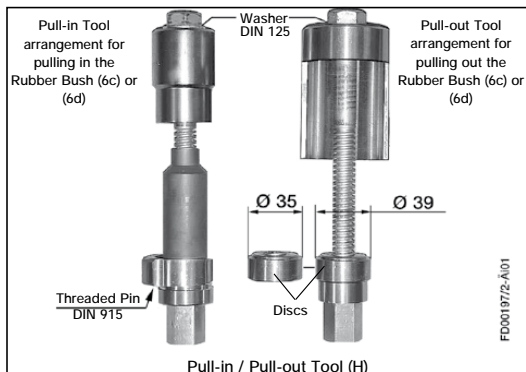
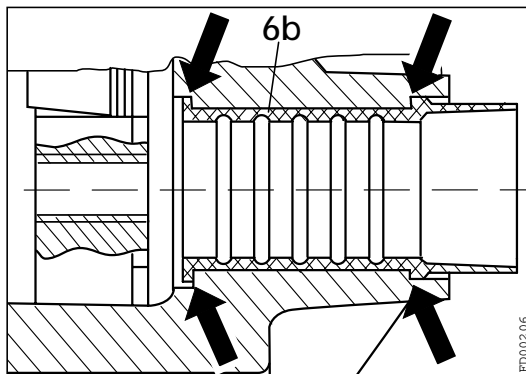
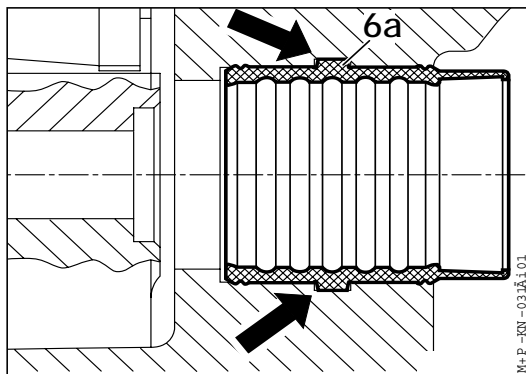
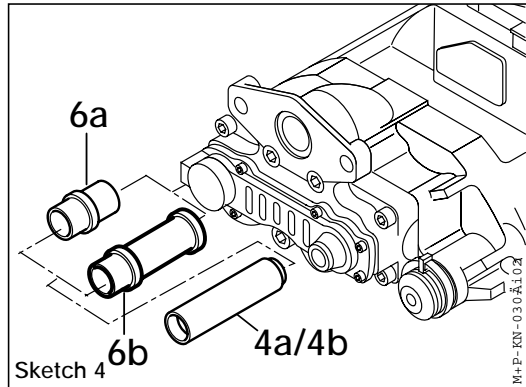

10.3.1 Removal of Rubber Bush (6c or 6d)

Remove Guide Pin (4c or 4d) .

Clean Caliper in the area of the Rubber Bush.

Select appropriate disc for pressing out the Rubber Bush (6c or 6d). The disc locks into the Rubber Bush.

Position the Tool (H) (Part No. Z004198) as shown in the adjacent picture. Lightly screw on the nut by hand.

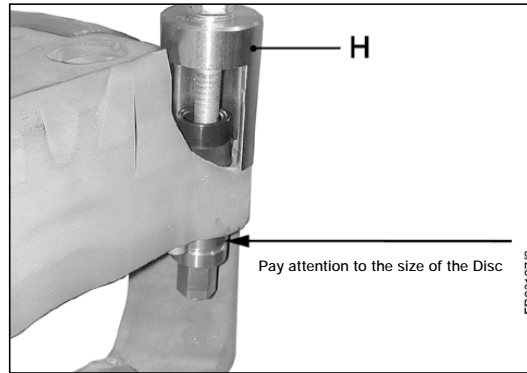

Hold the nut with a ring spanner and with a suitable socket or ring spanner tighten to remove the Rubber Bush.

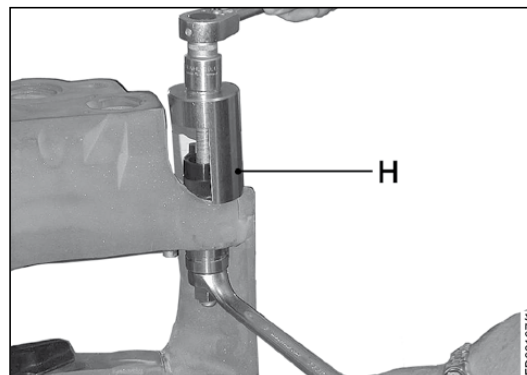

10.3.2 Fitting of Rubber Bush (6c or 6d)

Check bore for corrosion and clean.

Rubber Bush (6c) is existing in two different versions.

Make sure, that the diameter (ϕ) of the Metal Ring is the same as the diameter (ϕ) of the Rubber Bush Stopper.

ATTENTION!
If the wrong Rubber Bush (6c) is fitted, it can become loose, affect the Caliper Movement along the Guide Pins and reduce the braking force.

Insert Metal Ring of the Rubber Bush (6c or 6d) into the caliper bore.

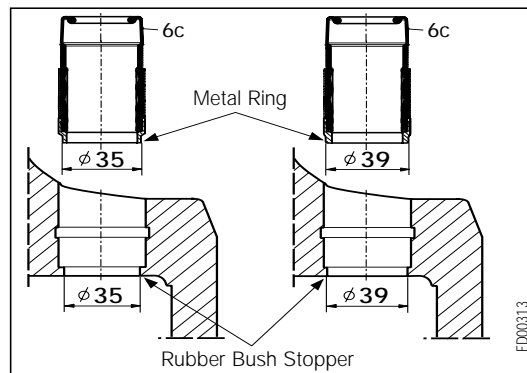

ATTENTION!
*The Metallic Sleeve of the Rubber Bush (6c or 6d) must not enter the caliper bore by more than 4 mm.
If the Metallic Sleeve of the Rubber Bush (6c or 6d) enters the caliper bore by more than 4 mm then the caliper bore is worn and the Caliper must be replaced.*

Unscrew Threaded Pin in the Tool (H), so that there is no projection at the contact surface - see sketch 2 on page 46.

Push Rubber Bush (6c or 6d) into the Tool (H) - see sketch 1 on page 46.

Position Tool (H) with Rubber Bush (6c or 6d) as shown in adjacent picture - see sketch 1 on page 46.

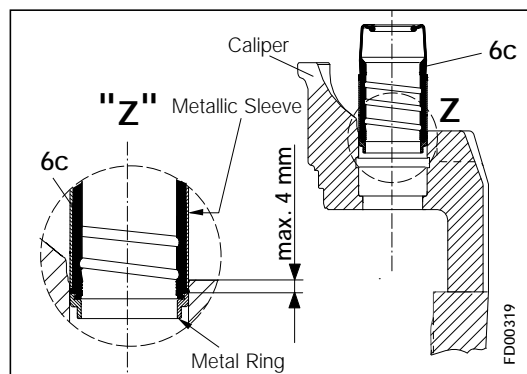

Lightly screw on the nut by hand.

Screw in Threaded Pin until it contacts the Caliper in order to adjust possible unevenness at the contact surface - see sketch 2.

Using Torque Wrench pull in Rubber Bush (6c or 6d) (min. 8 Nm up to max. 45 Nm).

Note:

Do not tilt the Rubber Bush (6c) or (6d) when pulling-in.

Remove the Tool.

ATTENTION!
If the torque is < 8 Nm or > 45 Nm, then the Caliper must be replaced. Failure to replace the Caliper could lead to a guidance failure.

ATTENTION!
The Metal Ring (see arrows in sketch 3) must not move. When checking for movement, then the Sealing Elements of the Rubber Bush (6c or 6d) must not be damaged.

Grease the interior of the Rubber Bush (6c or 6d) with **white** Grease (Part No. II14525 or II32868).

ATTENTION!
The Guide Pins (4 and 5) as well as the Caliper Bolts (39 and 40) are highly stressed items. They must be replaced whenever the Caliper (1) is removed from the Carrier (2).

Push Guide Pin (4c or 4d) from the inside of the Caliper into the Rubber Bush (6c or 6d).

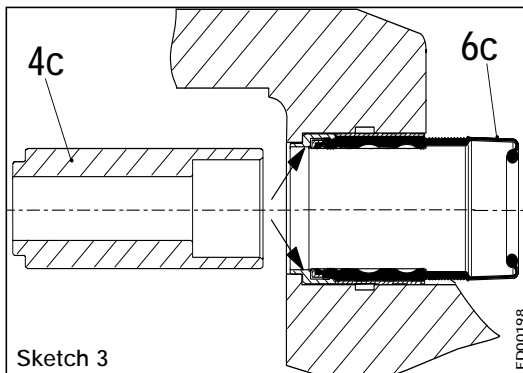
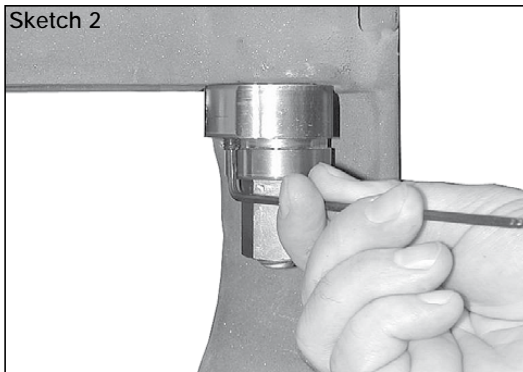
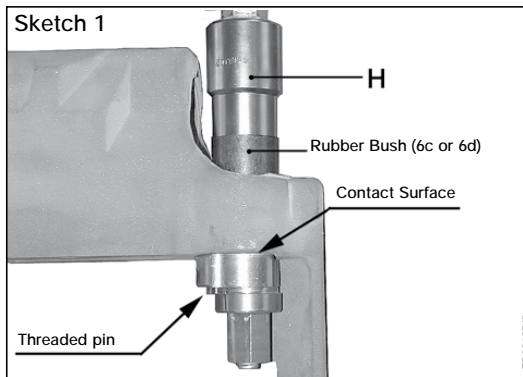

FD00197/5

FD00198

ANNEX 1

Road Number:		
Fleet/Location/Depot:		
VIN:		
Vehicle type:		
Order:		
Vehicle mileage	In miles	
	In KM	
In Service date		
Repair date (same date per vehicle or add new line)		
Drive axle brake caliper (SN)	Drive axle AVN132	serial no.
		Part no.
	Removed (Knorr-Bremse serial no.)	Left
		Right
	Installed (Knorr-Bremse serial no.)	Left
		Right
	Kind of work done (specify which side)	TRR
		CRR
		CRB
	First add the kind of work. For TRR (Tire Removal Reinstallation), CRR (Caliper Removal and Reinstallation) add your respective work time into row "Labor for R&R", for CRB (Caliper Rebushing) add your work time into row "Labor for rebushing"	Reference no.
		Claimant
		Labor for R&R (removal and reinstallation) (in hours)
Labor for rebushing (in hours)		
Comments regarding the work done and if travel costs or miscellaneous cost are required please comment / *receipts needed		