



Safety Recall

Code: 42i7

REVISION

Subject	Rear Shock Absorbers															
Release Date	June 19, 2018															
Revision Summary	Updated claiming instructions to include additional criteria															
Affected Vehicles	<p>U.S.A. & CANADA: 2018 MY Volkswagen Tiguan</p> <p><i>Check Campaigns/Actions screen in Elsa on the day of repair to verify that a VIN qualifies for repair under this action. Elsa is the <u>only</u> valid campaign inquiry & verification source.</i></p> <ul style="list-style-type: none"> ✓ Campaign status must show "open." ✓ If Elsa shows other open action(s), inform your customer so that the work can also be completed at the same time the vehicle is in the workshop for this campaign. 															
Problem Description	In affected vehicles, a lower loop of a rear shock absorber may separate from its base due to an incorrect supplier welding process. If a failure occurs, the lower loop of a rear shock absorber may detach from the base cup and destabilize the vehicle, potentially resulting in a crash without warning.															
Corrective Action	<p>Inspect, and if necessary replace one or both rear shock absorbers:</p> <ul style="list-style-type: none"> ✓ If no replacement necessary, enter recall claim and release vehicle. <p><u>Vehicle Repair Availability:</u></p> <table border="1"> <thead> <tr> <th>Criteria</th> <th>Part Number</th> <th>Repair Status</th> </tr> </thead> <tbody> <tr> <td>AM or M2</td> <td>5QN513049AM</td> <td>Repair Available</td> </tr> <tr> <td>AN or N2</td> <td>5QN513049AN</td> <td>Repair Available</td> </tr> <tr> <td>AQ</td> <td>5QN513049AQ</td> <td>Repair Available</td> </tr> <tr> <td>AR or R2</td> <td>5QN513049AR</td> <td>Repair Available</td> </tr> </tbody> </table>	Criteria	Part Number	Repair Status	AM or M2	5QN513049AM	Repair Available	AN or N2	5QN513049AN	Repair Available	AQ	5QN513049AQ	Repair Available	AR or R2	5QN513049AR	Repair Available
Criteria	Part Number	Repair Status														
AM or M2	5QN513049AM	Repair Available														
AN or N2	5QN513049AN	Repair Available														
AQ	5QN513049AQ	Repair Available														
AR or R2	5QN513049AR	Repair Available														
Precautions	Owners who hear a banging noise coming from the rear of the vehicle are advised to stop driving as soon as it is safe to do so and contact a Volkswagen dealer to make arrangements to have the vehicle towed to the dealer for inspection without delay.															

Parts Information	Parts are on Upper Order Limit. Please submit the backordered sales document number to upperorderlimits@vw.com to have additional parts released.
Code Visibility	<p>On or about May 21, 2018, affected vehicles were listed on the Inventory Vehicle Open Campaign Action report under My Dealership Reports (found on www.vw.com & OMD Web). A list was not posted for dealers who did not have any affected vehicles.</p> <p>On or about May 21, 2018, this campaign code showed open on affected vehicles in Elsa.</p> <p>On or about May 21, 2018, affected vehicles were identified with this campaign code in the VIN Lookup tool at www.vw.com and on the NHTSA VIN lookup tool at www.safercar.gov.</p>
Owner Notification	Owner notification took place in May 2018.
Additional Information	<p>Please alert everyone in your dealership about this action, including Sales, Service, Parts and Accounting personnel. Contact Warranty if you have any questions.</p> <p>IMPORTANT REMINDER ON VEHICLES AFFECTED BY SAFETY & COMPLIANCE RECALLS</p> <p><u>New Vehicles in Dealer Inventory:</u> It is a violation of Federal law for a dealer to deliver a new motor vehicle or any new or used item of motor vehicle equipment (including a tire) covered by this notification under a sale or lease until the defect or noncompliance is remedied. By law, dealers must correct, prior to delivery for sale or lease, any vehicle that fails to comply with an applicable Federal Motor Vehicle Safety Standard or that contains a defect relating to motor vehicle safety.</p> <p><u>Pre-Owned Vehicles in Dealer Inventory:</u> Dealers should not deliver any pre-owned vehicles in their inventory which are involved in a safety or compliance recall until the defect has been remedied.</p> <p>Dealers must ensure that every affected inventory vehicle has this campaign completed <u>before delivery to consumers</u>.</p> <p>Fill out and affix Campaign Completion Label (CAMP 010 000) after work is complete. Labels can be ordered at no cost via the Compliance Label Ordering portal at www.vw.com.</p>

Claim Entry Instructions

After campaign has been completed, enter claim as soon as possible to help prevent work from being duplicated elsewhere. Attach the Elsa screen print showing action open on the day of repair to the repair order.

If customer refused campaign work:

- ✓ U.S. dealers: Submit request via WISE under the *Campaigns/Update/Recall Closure* option.
- ✓ Canada dealers: Upload the repair order [signed by customer] to Volkswagen WIN/Operations/Campaign Closure.

Service Number	42i7
Damage Code	0099
Parts Vendor Code	WWO
Claim Type	Sold vehicle: 7 10 Unsold vehicle: 7 90
Causal Indicator	Mark labor as causal
Vehicle Wash/Loaner	Do not claim wash/loaner under this action

Vehicles have more than one criteria. Complete and claim all applicable criteria on one claim.

REQUIRED CLAIM COMMENT	Record the production date of both rear shocks in the comments field of the claim.
Criteria I.D.	AM and US -OR- M2

Check rear shocks. Updated part(s) present, no further work required

Labor operation: 0183 00 99 20 T.U.

-OR-

Check rear shocks; Replace ONE shock

Labor operation: 4293 55 99 60 T.U.

Quantity	Part Number	Description
1.00	5QN513049AM	Rear Shock Absorber*
1.00	N 10106402	Nut – Shock to Lower Control Arm
1.00	N 10628301	Bolt – Shock to Lower Control Arm
2.00	N 90648402	Bolt – Shock Mount to Body
1.00	WHT007127	Nut – Shock to Shock Mount

-OR-

Check rear shocks; Replace TWO shocks

Labor operation: 4293 56 99 110 T.U.

Quantity	Part Number	Description
2.00	5QN513049AM	Rear Shock Absorber*
2.00	N 10106402	Nut – Shock to Lower Control Arm
2.00	N 10628301	Bolt – Shock to Lower Control Arm
4.00	N 90648402	Bolt – Shock Mount to Body
2.00	WHT007127	Nut – Shock to Shock Mount

Continued on next page

The repair information in this document is intended for use only by skilled technicians who have the proper tools, equipment and training to correctly and safely maintain your vehicle. These procedures are not intended to be attempted by "do-it-yourselfers," and you should not assume this document applies to your vehicle, or that your vehicle has the condition described. To determine whether this information applies, contact an authorized Volkswagen dealer. ©2018 Volkswagen Group of America, Inc. and Volkswagen Canada. All Rights Reserved.

Criteria I.D.	AN and US -OR- N2																																				
	<p>Check rear shocks. Updated part(s) present, no further work required</p> <p>Labor operation: 0183 00 99 20 T.U.</p> <p>-OR-</p> <p>Check rear shocks; Replace ONE shock</p> <p>Labor operation: 4293 55 99 60 T.U.</p> <table border="1"> <thead> <tr> <th>Quantity</th> <th>Part Number</th> <th>Description</th> </tr> </thead> <tbody> <tr> <td>1.00</td> <td>5QN513049AN</td> <td>Rear Shock Absorber*</td> </tr> <tr> <td>1.00</td> <td>N 10106402</td> <td>Nut – Shock to Lower Control Arm</td> </tr> <tr> <td>1.00</td> <td>N 10628301</td> <td>Bolt – Shock to Lower Control Arm</td> </tr> <tr> <td>2.00</td> <td>N 90648402</td> <td>Bolt – Shock Mount to Body</td> </tr> <tr> <td>1.00</td> <td>WHT007127</td> <td>Nut – Shock to Shock Mount</td> </tr> </tbody> </table> <p>-OR-</p> <p>Check rear shocks; Replace TWO shocks</p> <p>Labor operation: 4293 56 99 110 T.U.</p> <table border="1"> <thead> <tr> <th>Quantity</th> <th>Part Number</th> <th>Description</th> </tr> </thead> <tbody> <tr> <td>2.00</td> <td>5QN513049AN</td> <td>Rear Shock Absorber*</td> </tr> <tr> <td>2.00</td> <td>N 10106402</td> <td>Nut – Shock to Lower Control Arm</td> </tr> <tr> <td>2.00</td> <td>N 10628301</td> <td>Bolt – Shock to Lower Control Arm</td> </tr> <tr> <td>4.00</td> <td>N 90648402</td> <td>Bolt – Shock Mount to Body</td> </tr> <tr> <td>2.00</td> <td>WHT007127</td> <td>Nut – Shock to Shock Mount</td> </tr> </tbody> </table>	Quantity	Part Number	Description	1.00	5QN513049AN	Rear Shock Absorber*	1.00	N 10106402	Nut – Shock to Lower Control Arm	1.00	N 10628301	Bolt – Shock to Lower Control Arm	2.00	N 90648402	Bolt – Shock Mount to Body	1.00	WHT007127	Nut – Shock to Shock Mount	Quantity	Part Number	Description	2.00	5QN513049AN	Rear Shock Absorber*	2.00	N 10106402	Nut – Shock to Lower Control Arm	2.00	N 10628301	Bolt – Shock to Lower Control Arm	4.00	N 90648402	Bolt – Shock Mount to Body	2.00	WHT007127	Nut – Shock to Shock Mount
Quantity	Part Number	Description																																			
1.00	5QN513049AN	Rear Shock Absorber*																																			
1.00	N 10106402	Nut – Shock to Lower Control Arm																																			
1.00	N 10628301	Bolt – Shock to Lower Control Arm																																			
2.00	N 90648402	Bolt – Shock Mount to Body																																			
1.00	WHT007127	Nut – Shock to Shock Mount																																			
Quantity	Part Number	Description																																			
2.00	5QN513049AN	Rear Shock Absorber*																																			
2.00	N 10106402	Nut – Shock to Lower Control Arm																																			
2.00	N 10628301	Bolt – Shock to Lower Control Arm																																			
4.00	N 90648402	Bolt – Shock Mount to Body																																			
2.00	WHT007127	Nut – Shock to Shock Mount																																			

Continued on next page

Criteria I.D.	AQ and US																																				
	<p>Check rear shocks. Updated part(s) present, no further work required</p> <p>Labor operation: 0183 00 99 20 T.U.</p> <p>-OR-</p> <p>Check rear shocks; Replace ONE shock</p> <p>Labor operation: 4293 55 99 60 T.U.</p> <table border="1"> <thead> <tr> <th>Quantity</th> <th>Part Number</th> <th>Description</th> </tr> </thead> <tbody> <tr> <td>1.00</td> <td>5QN513049AQ</td> <td>Rear Shock Absorber*</td> </tr> <tr> <td>1.00</td> <td>N 10106402</td> <td>Nut – Shock to Lower Control Arm</td> </tr> <tr> <td>1.00</td> <td>N 10628301</td> <td>Bolt – Shock to Lower Control Arm</td> </tr> <tr> <td>2.00</td> <td>N 90648402</td> <td>Bolt – Shock Mount to Body</td> </tr> <tr> <td>1.00</td> <td>WHT007127</td> <td>Nut – Shock to Shock Mount</td> </tr> </tbody> </table> <p>-OR-</p> <p>Check rear shocks; Replace TWO shocks</p> <p>Labor operation: 4293 56 99 110 T.U.</p> <table border="1"> <thead> <tr> <th>Quantity</th> <th>Part Number</th> <th>Description</th> </tr> </thead> <tbody> <tr> <td>2.00</td> <td>5QN513049AQ</td> <td>Rear Shock Absorber*</td> </tr> <tr> <td>2.00</td> <td>N 10106402</td> <td>Nut – Shock to Lower Control Arm</td> </tr> <tr> <td>2.00</td> <td>N 10628301</td> <td>Bolt – Shock to Lower Control Arm</td> </tr> <tr> <td>4.00</td> <td>N 90648402</td> <td>Bolt – Shock Mount to Body</td> </tr> <tr> <td>2.00</td> <td>WHT007127</td> <td>Nut – Shock to Shock Mount</td> </tr> </tbody> </table>	Quantity	Part Number	Description	1.00	5QN513049AQ	Rear Shock Absorber*	1.00	N 10106402	Nut – Shock to Lower Control Arm	1.00	N 10628301	Bolt – Shock to Lower Control Arm	2.00	N 90648402	Bolt – Shock Mount to Body	1.00	WHT007127	Nut – Shock to Shock Mount	Quantity	Part Number	Description	2.00	5QN513049AQ	Rear Shock Absorber*	2.00	N 10106402	Nut – Shock to Lower Control Arm	2.00	N 10628301	Bolt – Shock to Lower Control Arm	4.00	N 90648402	Bolt – Shock Mount to Body	2.00	WHT007127	Nut – Shock to Shock Mount
Quantity	Part Number	Description																																			
1.00	5QN513049AQ	Rear Shock Absorber*																																			
1.00	N 10106402	Nut – Shock to Lower Control Arm																																			
1.00	N 10628301	Bolt – Shock to Lower Control Arm																																			
2.00	N 90648402	Bolt – Shock Mount to Body																																			
1.00	WHT007127	Nut – Shock to Shock Mount																																			
Quantity	Part Number	Description																																			
2.00	5QN513049AQ	Rear Shock Absorber*																																			
2.00	N 10106402	Nut – Shock to Lower Control Arm																																			
2.00	N 10628301	Bolt – Shock to Lower Control Arm																																			
4.00	N 90648402	Bolt – Shock Mount to Body																																			
2.00	WHT007127	Nut – Shock to Shock Mount																																			

Continued on next page

Criteria I.D.	AR and US -OR- R2																			
	Check rear shocks. Updated part(s) present, no further work required Labor operation: 0183 00 99 20 T.U. -OR- Check rear shocks; Replace ONE shock Labor operation: 4293 55 99 60 T.U.																			
	<table border="1"> <thead> <tr> <th>Quantity</th> <th>Part Number</th> <th>Description</th> </tr> </thead> <tbody> <tr> <td>1.00</td> <td>5QN513049AR</td> <td>Rear Shock Absorber*</td> </tr> <tr> <td>1.00</td> <td>N 10106402</td> <td>Nut – Shock to Lower Control Arm</td> </tr> <tr> <td>1.00</td> <td>N 10628301</td> <td>Bolt – Shock to Lower Control Arm</td> </tr> <tr> <td>2.00</td> <td>N 90648402</td> <td>Bolt – Shock Mount to Body</td> </tr> <tr> <td>1.00</td> <td>WHT007127</td> <td>Nut – Shock to Shock Mount</td> </tr> </tbody> </table>		Quantity	Part Number	Description	1.00	5QN513049AR	Rear Shock Absorber*	1.00	N 10106402	Nut – Shock to Lower Control Arm	1.00	N 10628301	Bolt – Shock to Lower Control Arm	2.00	N 90648402	Bolt – Shock Mount to Body	1.00	WHT007127	Nut – Shock to Shock Mount
Quantity	Part Number	Description																		
1.00	5QN513049AR	Rear Shock Absorber*																		
1.00	N 10106402	Nut – Shock to Lower Control Arm																		
1.00	N 10628301	Bolt – Shock to Lower Control Arm																		
2.00	N 90648402	Bolt – Shock Mount to Body																		
1.00	WHT007127	Nut – Shock to Shock Mount																		
	-OR- Check rear shocks; Replace TWO shocks Labor operation: 4293 56 99 110 T.U.																			
	<table border="1"> <thead> <tr> <th>Quantity</th> <th>Part Number</th> <th>Description</th> </tr> </thead> <tbody> <tr> <td>2.00</td> <td>5QN513049AR</td> <td>Rear Shock Absorber*</td> </tr> <tr> <td>2.00</td> <td>N 10106402</td> <td>Nut – Shock to Lower Control Arm</td> </tr> <tr> <td>2.00</td> <td>N 10628301</td> <td>Bolt – Shock to Lower Control Arm</td> </tr> <tr> <td>4.00</td> <td>N 90648402</td> <td>Bolt – Shock Mount to Body</td> </tr> <tr> <td>2.00</td> <td>WHT007127</td> <td>Nut – Shock to Shock Mount</td> </tr> </tbody> </table>		Quantity	Part Number	Description	2.00	5QN513049AR	Rear Shock Absorber*	2.00	N 10106402	Nut – Shock to Lower Control Arm	2.00	N 10628301	Bolt – Shock to Lower Control Arm	4.00	N 90648402	Bolt – Shock Mount to Body	2.00	WHT007127	Nut – Shock to Shock Mount
Quantity	Part Number	Description																		
2.00	5QN513049AR	Rear Shock Absorber*																		
2.00	N 10106402	Nut – Shock to Lower Control Arm																		
2.00	N 10628301	Bolt – Shock to Lower Control Arm																		
4.00	N 90648402	Bolt – Shock Mount to Body																		
2.00	WHT007127	Nut – Shock to Shock Mount																		

The repair information in this document is intended for use only by skilled technicians who have the proper tools, equipment and training to correctly and safely maintain your vehicle. These procedures are not intended to be attempted by "do-it-yourselfers," and you should not assume this document applies to your vehicle, or that your vehicle has the condition described. To determine whether this information applies, contact an authorized Volkswagen dealer. ©2018 Volkswagen Group of America, Inc. and Volkswagen Canada. All Rights Reserved.

NOTE

- Damages resulting from improper repair or failure to follow these work instructions are the dealer's responsibility and are not eligible for reimbursement under this action.
- This procedure must be read in its entirety prior to performing the repair.
- Due to variations in vehicle equipment and options, the steps/illustrations in this work procedure may not identically match all affected vehicles.
- Diagnosis and repair of pre-existing conditions in the vehicle are not covered under this action.
- When working during extreme temperatures, it is recommended that the vehicle be allowed to acclimate inside the shop to avoid temperature-related component damage/breakage.

Required Parts (if necessary)

<u>Criteria</u>	<u>Quantity</u>	<u>Part Number</u>	<u>Part Description</u>	<u>Position</u>
AM or M2	Up to 2	5QN513049AM	Rear Shock Absorber	1
AN or N2	Up to 2	5QN513049AN		
AQ	Up to 2	5QN513049AQ		
AR or R2	Up to 2	5QN513049AR		
ALL	Up to 2	N 10106402	Nut – Shock to Lower Control Arm	2
	Up to 2	N 10628301	Bolt – Shock to Lower Control Arm	3
	Up to 4	N 90648402	Bolt – Shock Mount to Body	4
	Up to 2	WHT007127	Nut – Shock to Shock Mount	5

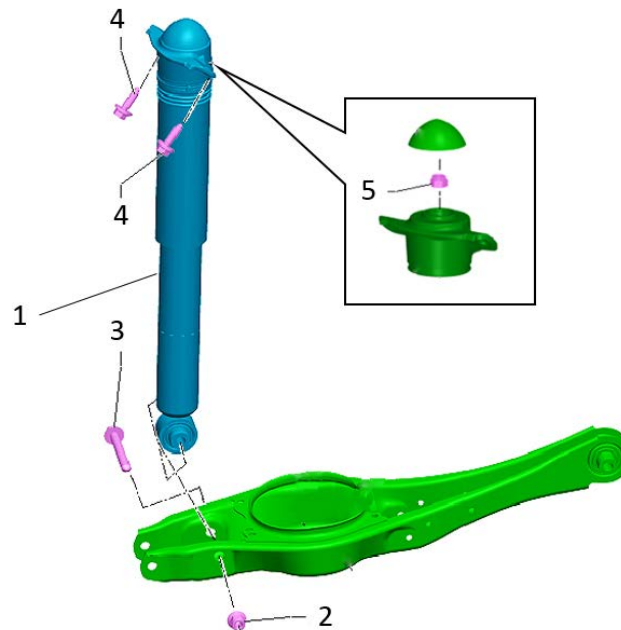

The repair information in this document is intended for use only by skilled technicians who have the proper tools, equipment and training to correctly and safely maintain your vehicle. These procedures are not intended to be attempted by "do-it-yourselfers," and you should not assume this document applies to your vehicle, or that your vehicle has the condition described. To determine whether this information applies, contact an authorized Volkswagen dealer. ©2018 Volkswagen Group of America, Inc. and Volkswagen Canada. All Rights Reserved.

Required Tools



 <p>Torque Wrench 5-50 Nm -VAG1331- (or equivalent)</p>	 <p>Shock Absorber Set -T10001- (or equivalent)</p>
 <p>Tensioning Strap -T10038- (or equivalent)</p>	 <p>Engine and Gearbox Jack -VAS6931- (or equivalent)</p>
 <p>Torque Wrench 40 - 200 Nm -VAG1332- (or equivalent)</p>	 <p>Engine/Gearbox Jack Adapter - Wheel Hub Support -T10149-</p>
 <p>Engine/Gearbox Jack - Gearbox Support -T10337- (or equivalent)</p>	

Repair Instruction

Section A - Check for Previous Repair

TIP

If Campaign Completion label is present, no further work is required.

Applicable criteria ID(s)	Campaign/Action Status
01 	Open 

EXAMPLE

- Enter the VIN in Elsa and proceed to the “Campaign/Action” screen.

TIP

On the date of repair, print this screen and keep a copy with the repair order.

- Confirm the Campaign/Action is open <arrow 1>. If the status is closed, no further work is required.
- Note the Applicable Criteria ID <arrow 2> for use in determining the correct work to be done and corresponding parts associated.

Proceed to Section B

Section B – Rear Shock Absorber Inspection

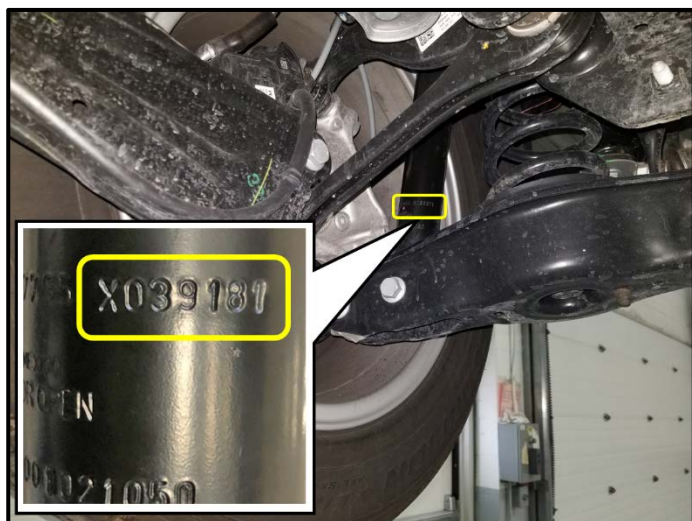

Production Number

X039181

Day

Production Days Requiring Replacement

010	011	012	013	014	015	016	017	018	019
020	021	022	023	024	025	026	027	028	029
030	031	032	033	034	035	036	037	038	039
040	041	042	043	044	045	046	047	048	049
050	051	052	053	054					

NOTE

- Both rear shock absorbers must be inspected.
 - It is possible that only one shock may require replacement.
 - An inspection mirror may be required depending on the orientation of the shock.
- Raise the vehicle.
 - Inspect the production day on both rear shock absorbers **and record production number for both shocks on the repair order.**

All Criteria:

X **Proceed to Section C and replace affected shock if production day on one or both shock(s) is:**

- 010
- 054
- Any day *between* 010 and 054

✓ **If production day on BOTH shocks is NOT any of above, Proceed to Section D.**

Section C – Rear Shock Absorber Replacement

NOTE

- The following steps illustrate the replacement of one shock absorber. If both shock absorbers require replacement, the replacement procedure is identical.
- The rear fender liners do NOT require removal.

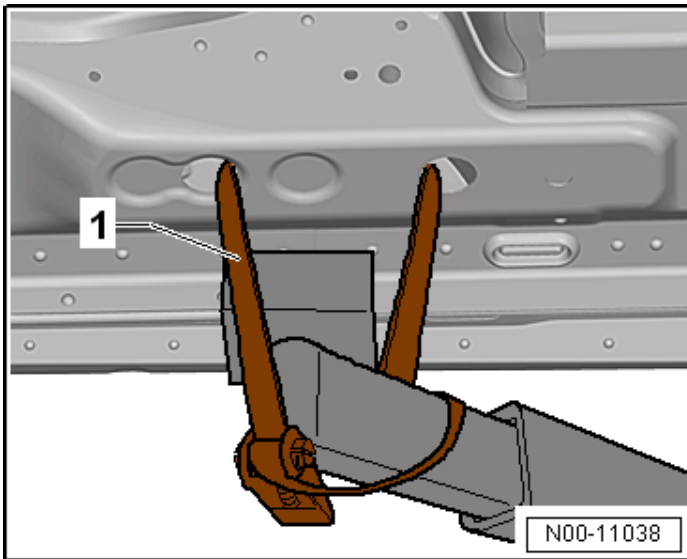

⚠ WARNING

The vehicle could slide off the hoist if it is not secured.

- Secure both rear sides of the vehicle on the hoist lifting arms using the -T10038- <1>.

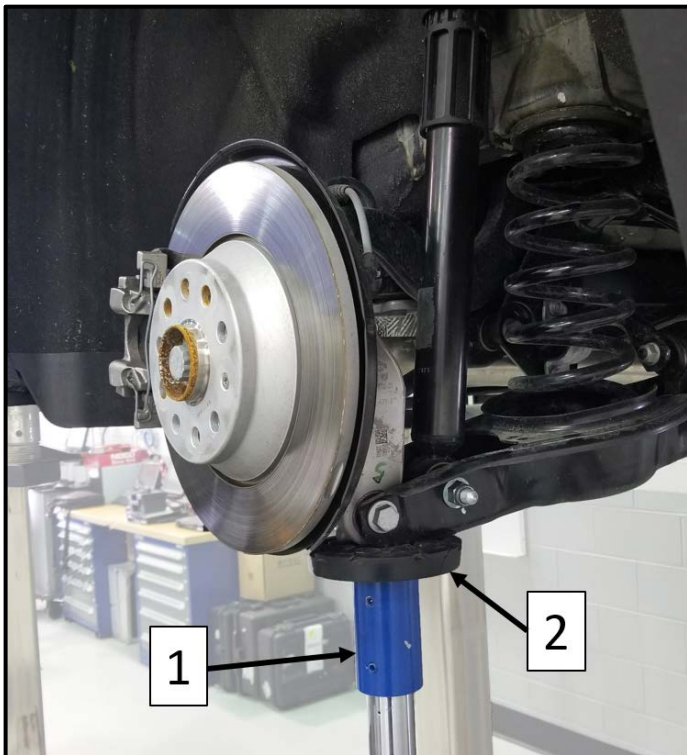

- Remove rear wheel.
- Position the -VAS6931- <1> with Engine/Gearbox Jack - Gearbox Support -T10337- <2> under the transverse link and apply slight upward pressure.

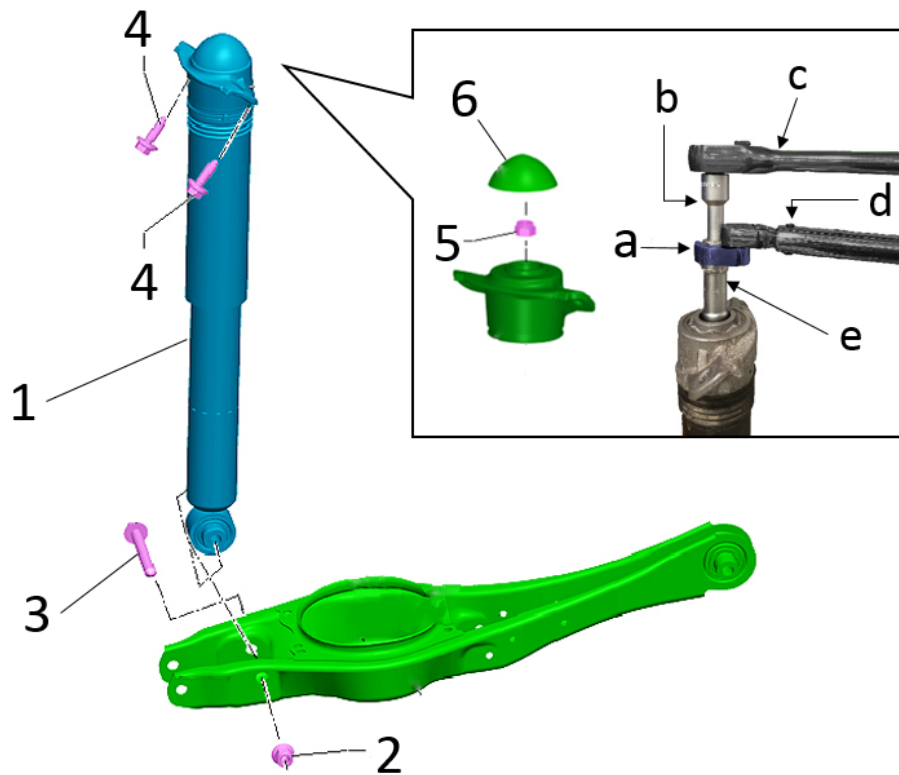

- Remove bolts <4>.
- Remove nut <2> and bolt <3>.
- Remove shock <1>.
- Remove cap <6>.
- Remove nut <5> using the following tools:
 - a) Commercially available 21mm Crowsfoot
 - b) Shock Absorber Set - Extension with Counter Holder 1 -T10001/9-
 - c) Commercially Available Ratchet
 - d) Torque Wrench 1331 5-50 Nm -VAG1331- (or equivalent)
 - e) Shock Absorber Set - Socket -T10001/1-

CAUTION

Do not use a torque wrench on Extension with Counter Holder 1 -T10001/9- . Trying to torque nut <5> this way could damage the new shock.

- Transfer shock mount with bumper and sleeve to new shock using new nut <5> and torque to 25 Nm using tools <a through e>.
- Install cap <6>.
- Install shock into vehicle and torque bolts <4> to 50 Nm + 45°.
- Install bolt <3> and nut <2>. While counterholding bolt <3>, torque nut <2> to 70 Nm + 180° in curb weight position (see next step for curb weight torquing instructions).

CAUTION

Axle components with bonded rubber bushings must be brought into the position they will be in when driving before they are tightened (curb weight position). Otherwise, the bonded rubber bushing will have tension, which will reduce the service life.

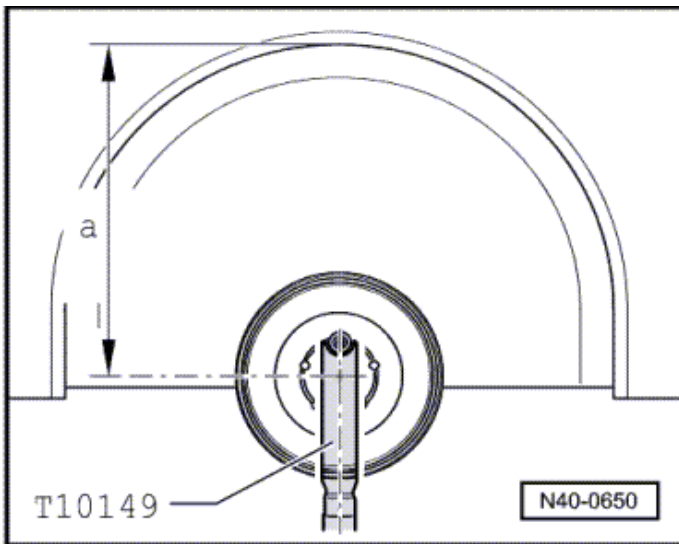

- Turn the wheel hub until one of the holes for the wheel bolts is on top.
- Install the -T10149- with a wheel bolt.
- Raise the suspension with the -VAS6931- until dimension <a> is achieved.
- Dimension <a> is dependent on the type of installed suspension.
 - FWD = 445 ± 10 mm.
 - AWD = 455 ± 10 mm.

⚠ CAUTION

Axle components with bonded rubber bushings must be brought into the position they will be in when driving before they are tightened (curb weight position). Otherwise, the bonded rubber bushing will have tension, which will reduce the service life.

- Remove tensioning straps.
- Remove -T10149-.
- Install wheel and torque to 120 Nm.

Proceed to Section D.

Section D – Campaign Completion Label

Install Campaign Completion Label

- Fill out and affix Campaign Completion Label, part number CAMP 010 000, next to the vehicle emission control information label.

TIP

Ensure Campaign Completion Label does not cover any existing label(s).

Proceed to Section E.

Section E - Parts Return/Disposal

Properly store (retain), destroy or dispose of removed parts in accordance with all state/province and local requirements, unless otherwise indicated and/or requested through the Warranty Parts Portal (WPP) for U.S. and the Part Destruction and Core Disposition Report for Canada.