



Safety Recall

Code: 69Q8

REVISION

Subject	TAKATA Driver Frontal Airbag Inflator
Revision Summary	Updated instructions for the mandatory Takata parts return process in Appendix B.
Release Date	July 21, 2018
Affected Vehicles	U.S.A. & CANADA: Certain 2006-2007 MY Volkswagen Passat Sedan & Passat Wagon vehicles equipped with a Takata driver frontal airbag <i>Check Campaigns/Actions screen in Elsa on the day of repair to verify that a VIN qualifies for repair under this action. Elsa is the <u>only</u> valid campaign inquiry & verification source.</i> <ul style="list-style-type: none">✓ Campaign status must show "open."✓ If Elsa shows other open action(s), inform your customer so that the work can also be completed at the same time the vehicle is in the workshop for this campaign.
Problem Description	The driver airbag may explode in a crash with airbag deployment. Sharp metal fragments can hit people and cause serious injury or death.
Corrective Action	Replace the driver frontal airbag inflator with a newly manufactured version. This repair is the <u>final</u> remedy.
Parts Information	Parts will be allocated weekly. Please email VWoAPartsSpecialists@vw.com with VIN if you do not have the proper part(s) in stock.
Code Visibility	On or about April 19, 2018, affected vehicles were listed on the Inventory Vehicle Open Campaign Action report under My Dealership Reports (found on www.vwhub.com & OMD Web). A list was not posted for dealers who did not have any affected vehicles. On or about April 19, 2018, this campaign code showed open on affected vehicles in Elsa. On or about April 19, 2018, affected vehicles were identified with this campaign code in the VIN Lookup tool at www.vw.com and on the NHTSA VIN lookup tool at www.safercar.gov .
Owner Notification	Owner notification took place in April 2018. Owner letter examples are included in this bulletin for your reference.

Additional Information

Please alert everyone in your dealership about this action, including Sales, Service, Parts and Accounting personnel. Contact Warranty if you have any questions.

IMPORTANT REMINDER ON VEHICLES AFFECTED BY SAFETY & COMPLIANCE RECALLS

New Vehicles in Dealer Inventory: It is a violation of Federal law for a dealer to deliver a new motor vehicle or any new or used item of motor vehicle equipment (including a tire) covered by this notification under a sale or lease until the defect or noncompliance is remedied. By law, dealers must correct, prior to delivery for sale or lease, any vehicle that fails to comply with an applicable Federal Motor Vehicle Safety Standard or that contains a defect relating to motor vehicle safety.

Pre-Owned Vehicles in Dealer Inventory: Dealers should not deliver any pre-owned vehicles in their inventory which are involved in a safety or compliance recall until the defect has been remedied.

Dealers must ensure that every affected inventory vehicle has this campaign completed before delivery to consumers.

Fill out and affix Campaign Completion Label (CAMP 010 000) after work is complete. Labels can be ordered at no cost via the Compliance Label Ordering portal at www.vwhub.com.

Claim Entry Instructions

After campaign has been completed, enter claim as soon as possible to help prevent work from being duplicated elsewhere. Attach the Elsa screen print showing action open on the day of repair to the repair order.

If customer refused campaign work:

- ✓ U.S. dealers: Submit request via WISE under the *Campaigns/Update/Recall Closure* option.
- ✓ Canada dealers: Fax repair order to Warranty at (905) 428-4811.

Service Number	69Q8							
Damage Code	0099							
Parts Vendor Code	WWO							
Claim Type	Sold vehicle: 7 10 Unsold vehicle: 7 90							
Causal Indicator	Mark airbag inflator kit* as causal part							
Vehicle Wash/Loaner	Do not claim wash/loaner under this action							
Criteria I.D.	N1							
	Install new airbag inflator kit. Labor operation: 6958 56 99 105 T.U.							
	<table border="1"> <thead> <tr> <th>Quantity</th> <th>Part Number</th> <th>Description</th> </tr> </thead> <tbody> <tr> <td>1.00</td> <td>3C0898201F*</td> <td>Airbag Inflator Kit Without Vibration Damper</td> </tr> </tbody> </table>		Quantity	Part Number	Description	1.00	3C0898201F*	Airbag Inflator Kit Without Vibration Damper
Quantity	Part Number	Description						
1.00	3C0898201F*	Airbag Inflator Kit Without Vibration Damper						
Criteria I.D.	T1							
	Install new airbag inflator kit. Labor operation: 6958 56 99 105 T.U.							
	<table border="1"> <thead> <tr> <th>Quantity</th> <th>Part Number</th> <th>Description</th> </tr> </thead> <tbody> <tr> <td>1.00</td> <td>3C0898201G*</td> <td>Airbag Inflator Kit With Vibration Damper</td> </tr> </tbody> </table>		Quantity	Part Number	Description	1.00	3C0898201G*	Airbag Inflator Kit With Vibration Damper
Quantity	Part Number	Description						
1.00	3C0898201G*	Airbag Inflator Kit With Vibration Damper						

Customer Letter Example (USA)

This notice applies to your vehicle: <VIN>

NHTSA: NEED

**Subject: Safety Recall 69Q8 - Takata Driver Frontal Airbag Inflator
Certain 2006-2007 Model Year Volkswagen Passat Sedan & Passat Wagon Vehicles Equipped with a Takata Driver Frontal Airbag**

Dear Volkswagen Owner,

This notice is sent to you in accordance with the National Traffic and Motor Vehicle Safety Act. Volkswagen has decided that a defect, which relates to motor vehicle safety, exists in certain 2006-2007 model year Volkswagen vehicles equipped with a Takata driver frontal airbag. Our records show that you are the owner of a vehicle affected by this action.

DANGER!

**The driver airbag may explode in a crash with airbag deployment.
Sharp metal fragments can hit people and cause serious injury or death.**

What should you do?	Schedule this recall repair immediately. Volkswagen dealers are the only locations authorized to complete the recall work. Please contact your local Volkswagen dealer directly to schedule this recall repair without delay. For your convenience, you can also visit www.vw.com/find-a-dealer to locate a dealer near you and schedule this service online.
What will we do?	To correct this defect, your Volkswagen dealer will replace the driver airbag inflator in your vehicle. This work will take about two hours to complete and will be performed for you free of charge. Please keep in mind that your dealer may need additional time for the preparation of the repair, as well as to accommodate their daily workshop schedule.
Lease vehicles and address changes	If you are the lessor and registered owner of the vehicle identified in this action, the law requires you to forward this letter immediately via first-class mail to the lessee within ten (10) days of receipt. If you have changed your address or sold the vehicle, please fill out the enclosed prepaid Owner Reply card and mail it to us so we can update our records.
Can we assist you further?	If your authorized Volkswagen dealer fails or is unable to complete this work free of charge within a reasonable time, or if you should have any questions about this communication, please don't hesitate to contact Customer CARE, Monday through Friday by phone at 800-893-5298. You are also welcome to chat through the "Contact Us" page http://www.vw.com/contact .
Checking your vehicle for open Recalls and Service Campaigns	To check your vehicle's eligibility for repair under this or any other recall/service campaign, please click on the Look Up Recalls link at www.vw.com and enter your Vehicle Identification Number (VIN) into the Recall/Service Campaign Lookup tool.

If you still cannot obtain satisfaction, you may file a complaint with: The Administrator, National Highway Traffic Safety Administration, 1200 New Jersey Avenue, SE., Washington, DC 20590; or call the toll-free Vehicle Safety Hotline at 1-888-327-4236 (TTY: 1-800-424-9153); or go to <http://www.safercar.gov>.

We apologize for any inconvenience this matter may cause; however we are taking this action to help ensure your safety and continued satisfaction with your vehicle.

Sincerely,

Volkswagen Customer Protection

Customer Letter Example (CANADA)

This notice applies to your vehicle: <VIN>

**Subject: Safety Recall 69Q8 - Takata Driver Frontal Airbag Inflator
Certain 2006-2007 Model Year Volkswagen Passat Sedan & Passat Wagon Vehicles Equipped with a
Takata Driver Frontal Airbag**

Dear Volkswagen Owner,

This notice is sent to you in accordance with the requirements of the Motor Vehicle Safety Act. Volkswagen has decided that a defect, which relates to motor vehicle safety, exists in certain 2006-2007 model year Volkswagen vehicles equipped with a Takata driver frontal airbag. Our records show that you are the owner of a vehicle affected by this action.

DANGER!

**The driver airbag may explode in a crash with airbag deployment.
Sharp metal fragments can hit people and cause serious injury or death.**

What should you do? Schedule this recall repair immediately.

Please contact your authorized Volkswagen dealer without delay to schedule this recall repair.

What will we do? To correct this defect, your authorized Volkswagen dealer will replace the driver airbag inflator in your vehicle. This work will take about two hours to complete and will be performed for you free of charge.

Please keep in mind that your dealer may need additional time for the preparation of the repair, as well as to accommodate their daily workshop schedule.

Lease vehicles and address changes If you are the lessor and registered owner of the vehicle identified in this action, the law requires you to forward this letter immediately via first-class mail to the lessee within ten (10) days of receipt. If you have changed your address or sold the vehicle, please fill out the enclosed prepaid Owner Reply card and mail it to us so we can update our records.

Can we assist you further? If your authorized Volkswagen dealer fails or is unable to complete this work free of charge within a reasonable time, please contact Customer Relations, Monday through Friday from 8AM to 8PM EST by phone at 1-800-822-8987 or via our "Contact Us" page at www.vw.ca.

We apologize for any inconvenience this matter may cause; however we are taking this action to help ensure your safety and continued satisfaction with your vehicle.

Sincerely,

Volkswagen Customer Protection

 DANGER

- The driver frontal airbag inflator could potentially rupture (due to propellant degradation occurring after long-term exposure to absolute high humidity and temperature cycling). In the event of an inflator rupture, in very rare cases metal fragments could pass through the airbag cushion material, which may result in serious injury or death.
- This Recall should be performed before any other work is performed on the vehicle.

 WARNING

Risk of injury. Refer to “Warning and Safety Precautions”, found in **Appendix A** at the end of this document.

 NOTE

- Damages resulting from improper repair or failure to follow these work instructions are the dealer’s responsibility and are not eligible for reimbursement under this action.
- This procedure must be read in its entirety prior to performing the repair.
- Due to variations in vehicle equipment and options, the steps/illustrations in this work procedure may not identically match all affected vehicles.
- Diagnosis and repair of pre-existing conditions in the vehicle are not covered under this action.

Required Parts

<u>Criteria</u>	<u>Quantity</u>	<u>Part Number</u>	<u>Part Description</u>
N1	1	3C0898201F	Airbag Inflator Kit Without Vibration Damper
T1	1	3C0898201G	Airbag Inflator Kit With Vibration Damper

 NOTE

All inflator kits include inflator, inflator nuts, horn ring bolts and one replacement horn ring spring.

Required Safety Equipment



- Ear Protection (locally sourced)



- Face Shield (locally sourced)

Required Tools

3409

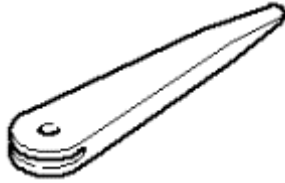

W00-0016

- Trim Removal Wedge – 3409 (or equivalent)



- ESD Work surface - VAS 6613



- Bar Code Scanner – VAS6161/1



- Airbag Support - T10568



- VAS6150D - Diagnostic Tester (or equivalent)



- VAG1410 – Torque Wrench (or equivalent)

Required Work Environment

⚠ WARNING

Risk of injury.

It is critical that a clean, uncongested work environment is utilized during the inflator replacement procedure. Extra tools, debris, etc... in the blast area of an airbag impose a danger in the event an airbag were to deploy. Ensure there are no loose components in the blast area of the airbag.

ⓘ NOTE

The work area must be in the vicinity of the scan tool and the vehicle in order to properly complete this procedure.



- Workbench that will support a vice.
- Work surface free of unnecessary tools, equipment and debris.

Repair Instruction

Section A - Check for Previous Repair

TIP

If Campaign Completion label is present, no further work is required.

Applicable criteria ID(s)	Campaign/Action Status
01 	Open 

EXAMPLE

- Enter the VIN in Elsa and proceed to the “Campaign/Action” screen.

TIP

On the date of repair, print this screen and keep a copy with the repair order.

- Confirm the Campaign/Action is open <arrow 1>. If the status is closed, no further work is required.
- Note the Applicable Criteria ID <arrow 2> for use in determining the correct work to be done and corresponding parts associated.

Proceed to Section B

Section B – Inflator Identification (all vehicles)

⚠ WARNING

Risk of injury.

- People in the immediate vicinity of the workplace must be protected from possible noise and projectiles.
- Pyrotechnic components can trigger unintentionally.
- In the event of unintentional deployment:
 - Single-stage inflators: allow airbag to cool down completely. Wait at least 10 minutes before handling.
 - Two-stage inflators: wait for second airbag ignition. Allow airbag to cool down completely. Wait at least 10 minutes before handling.



- Prior to beginning repairs, verify the horn is operational.

ⓘ NOTE

Diagnosis and repair of an inoperable horn, before or after inflator replacement, will not be covered under this campaign.



- Use the QR code or the link to view a video detailing the repair process prior to performing the repair.

<https://vwcup.track360.com/?p=vwiqCertification&id=11288>

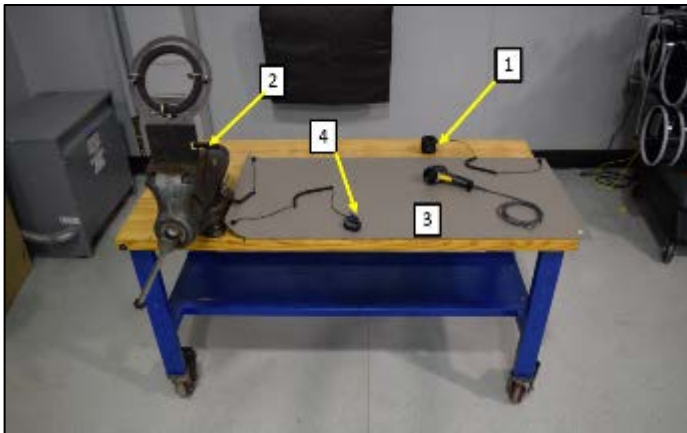

! NOTE	
•	Prior to beginning work, all parts and tools are to be placed on the ESD table mat.
•	The workstation must be in the vicinity of the vehicle.

- Assemble ESD workplace -VAS 6613- <1, 2, 3, and 4>.
- Plug ESD workplace into a wall socket using plug <1>.

! NOTE	
The wall socket or extension cord must have a sufficient ground.	

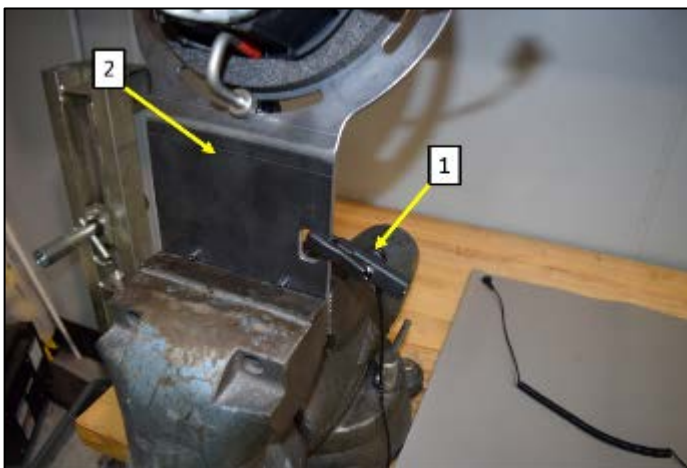

- Clamp Airbag Support T10568 <2> into the vice.
- Connect crocodile clip <1> to airbag support <2> and ESD workplace -VAS 6613-.



- Ensure ODIS is updated to the latest version.
- Connect vehicle diagnostic tester.
- Select Start Diagnosis function and identify vehicle.
- After identification of control units, Guided Fault Finding is started automatically.
- Follow the instructions on screen.

Offboard Diagnostic Information System Service - 3.1.1

Importer: 444 VIN: CCTA 2.0 l. Motronic/147kW
 Dealer: 03999 Engine:
 RO: --

Control modules | Orders | DISS | TSB | Test plan | Operation | **Special Functions**

Tests for the entire vehicle

Status	Tests
[-]	Showroom mode
	Special actions
[-]	Adapt Mechatronics software
[-]	Adapt SW for pwr. supply sys. ctrl. mod. (BCM)
[-]	Adapt airbag software
[-]	Adapt software steering wheel electronics
[-]	Adapt software, diesel, exhaust EA189 action Z3Q3
[-]	Production status documentation part number on the replacement airbag module/gas generator <arrow>
[-]	Reset the assembly site test/DTC memory
	Software version management

Perform test... Display documents

Your device is ready to use
 Device driver software installed successfully.

10:41 AM 1/13/2017

- In operating mode Special Functions, Select **“Production status documentation part number on the replacement airbag module/gas generator”** <arrow>.

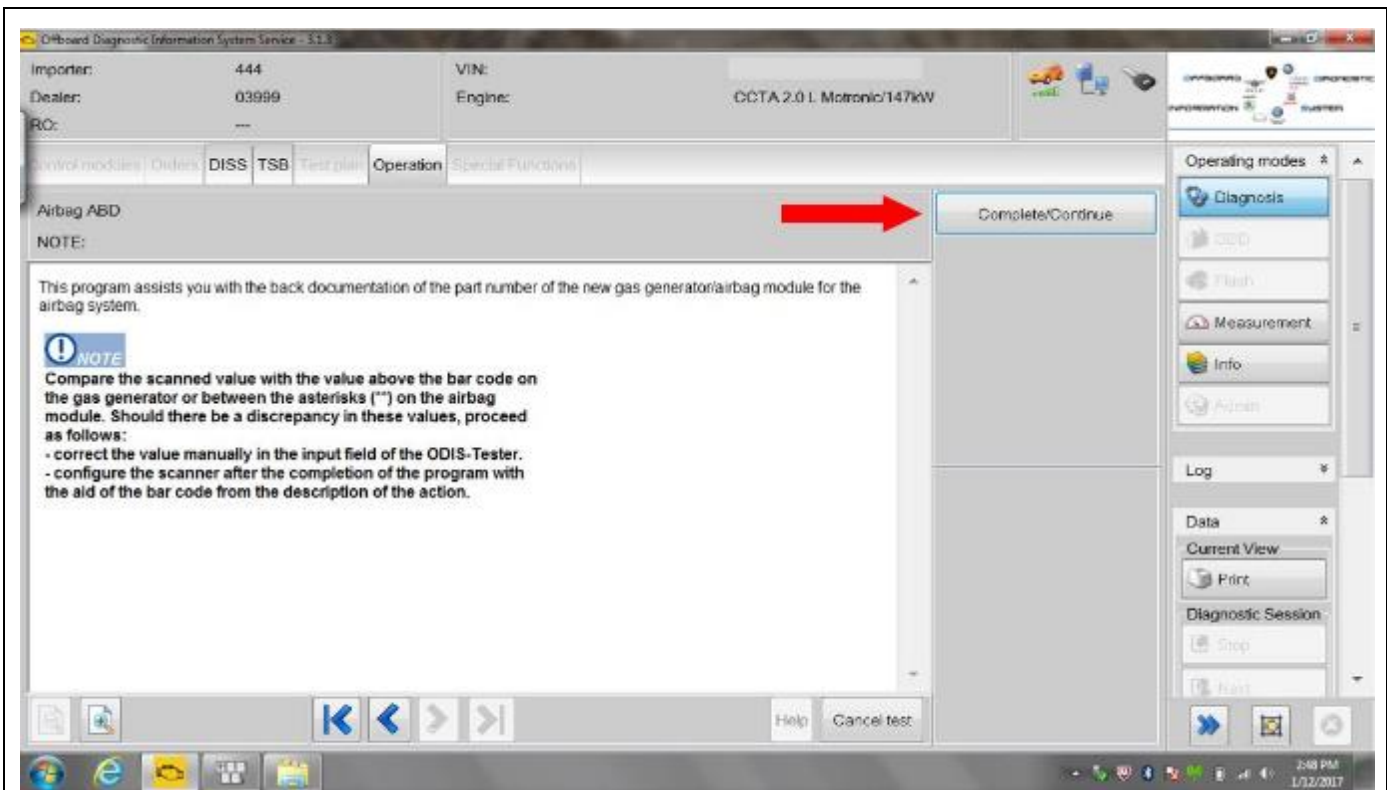

- Scanning the data matrix code during this test plan step calibrates the scanner to avoid error messages.
- Scanning the calibrating data matrix code may not have to be done every time (only when the scanner requires calibration). You will know if the scanner needs calibrating if the scanner does not scan the inflator's data matrix code.
- If the inflator data matrix code cannot be scanned, then print out this matrix shown below and scan the printout.



- After calibrating the scanner, select **“Complete/Continue”**

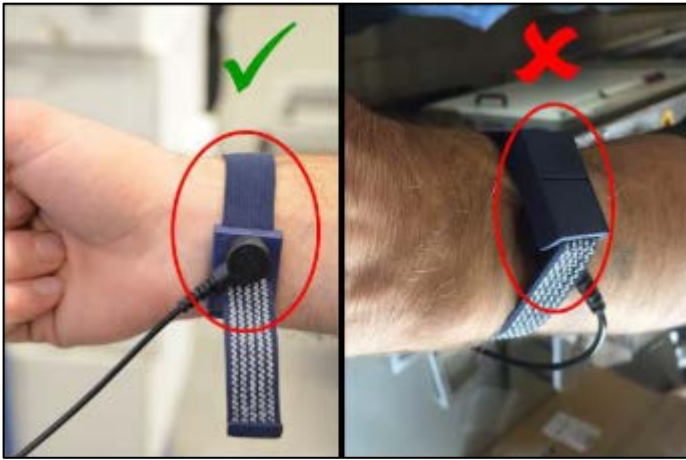

- Put the wrist strap from the ESD workplace on your wrist.

⚠ CAUTION

The white dots on the wrist strap must be against the skin.

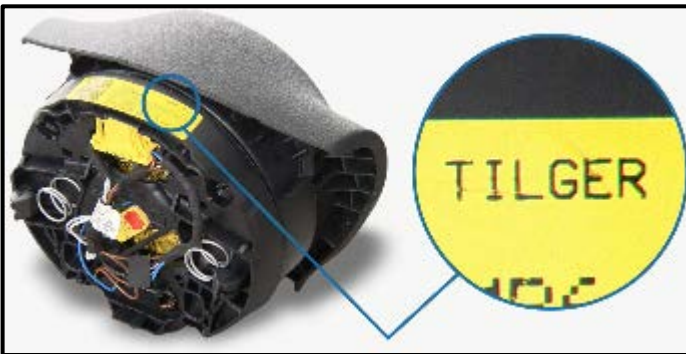

! NOTE

- There are two types of inflator. One version is “with vibration absorption” and one is “without vibration absorption”.
- Airbags with vibration absorption may be identified by the word “TILGER” on the label found on the airbag.

! NOTE

In the event an airbag had previously been replaced, the replacement airbag may have an inflator WITH the vibration absorber. If this situation is encountered, the inflator WITH vibration absorption **MUST** be installed:

- Repackage the previously scanned inflator and return to the parts department.
- Acquire the correct inflator from the parts department.
- Scan the new inflator using the GFF test plan.
- Install the new inflator, following the **“Inflator versions WITH vibration absorption”** instructions.



- Place the new inflator on the ESD mat.
- Scan the data matrix code of the new inflator at a distance of about 15 cm.

⚠ CAUTION

Ensure the correct inflator data matrix code is scanned at this time.

<u>Criteria</u>	<u>Part Number</u>
N1	3C0 898 201 F
T1	3C0 898 201 G

! NOTE

The photo is for reference only. The inflator that is installed may be either a single stage or dual stage inflator.



! NOTE

The data matrix code includes the values as shown.

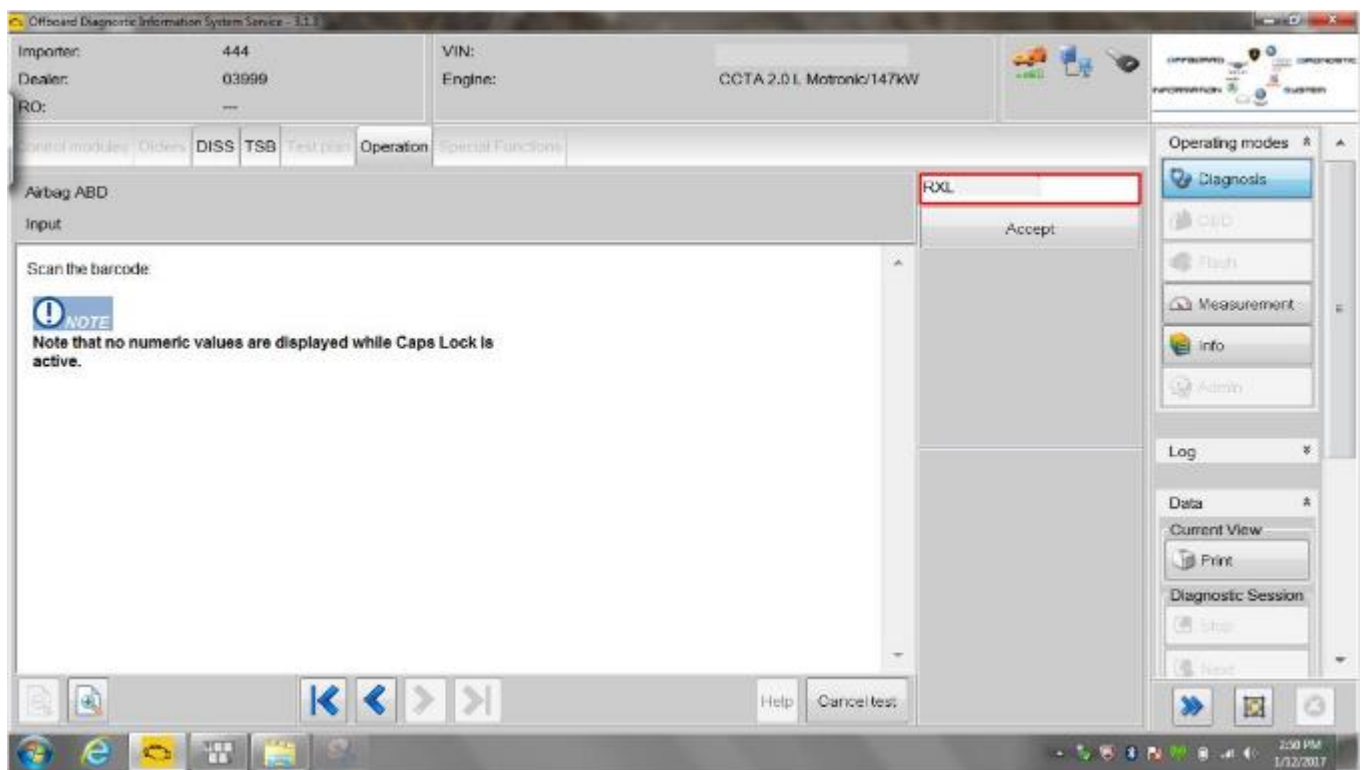

- Once the new inflator has been successfully scanned, press **“Accept”**

NOTE

- Compare the scanned value with the value shown above the data matrix code on the new inflator.
- If there is a discrepancy, manually enter the value from the new inflator in the input field.
- If no value appears, recalibrate the scanner.

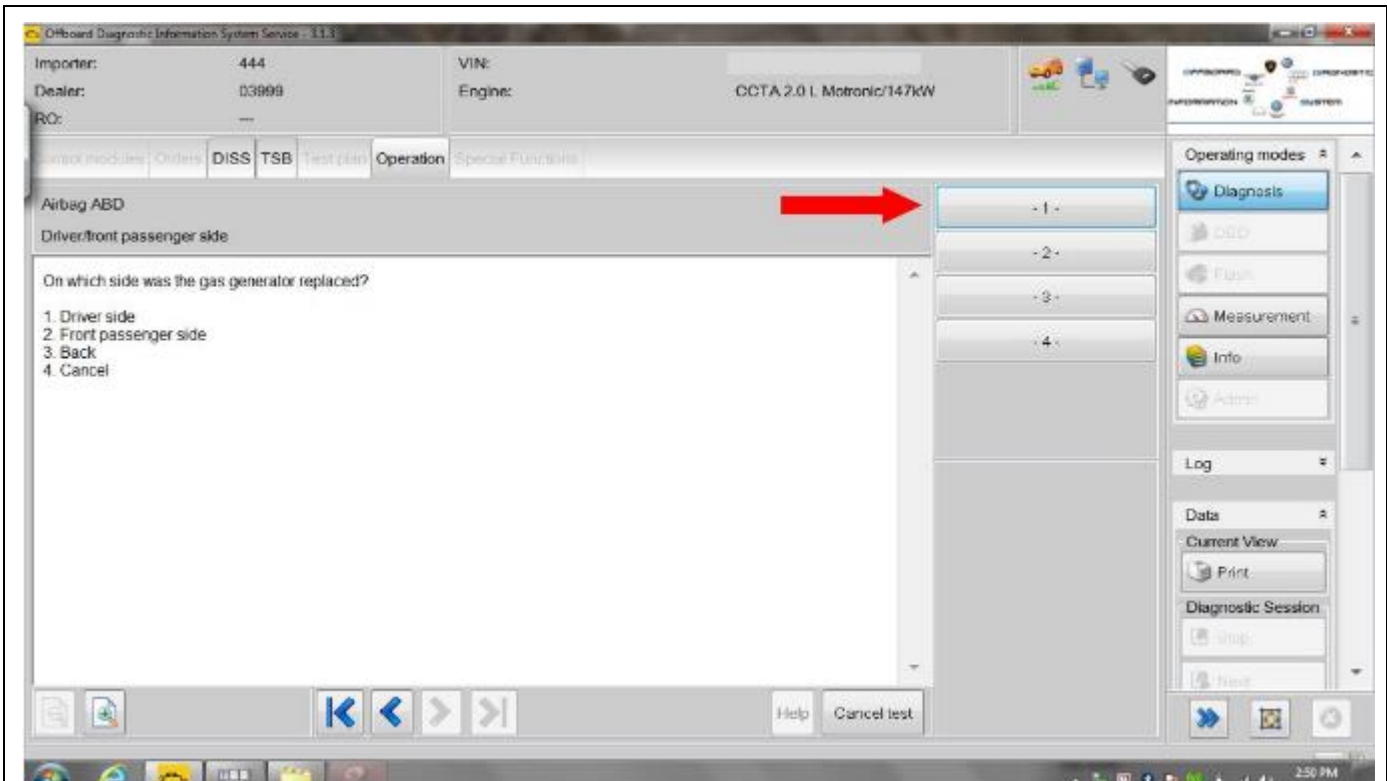

- Select option 1 indicating that the Driver side inflator was replaced.
- After selecting option 1, a valid GeKo ID will need to be entered in order to upload the new inflator identification.
- Upload diagnostic log online.

NOTE

RISK of Non-payment!

Diagnosis logs must be sent on-line after the test plan is completed to be considered for reimbursement.

Continue to Section C.

Section C – Battery Disconnect



⚠ WARNING

Accident risk. When working on pyrotechnic components (such as airbags and belt tensioners), the battery must be disconnected with the ignition switched **ON**.

! NOTE

Before disconnecting the battery, it is recommended to record the customer's radio presets so they can be restored before returning vehicle to the customer.

- Turn **ON** the ignition.
- Move the driver seat to the most rearward position.
- Fully recline driver seat.

⚠ CAUTION

Reclining the driver seat before disconnecting the battery allows for additional safety in the event Terminal 15 power is not restored when reconnecting the battery at the end of the repair.

- Open the battery protective covering <1>.
- Loosen the nut <1>.
- Remove and isolate the battery ground cable terminal from the battery terminal.

Continue to Section D.

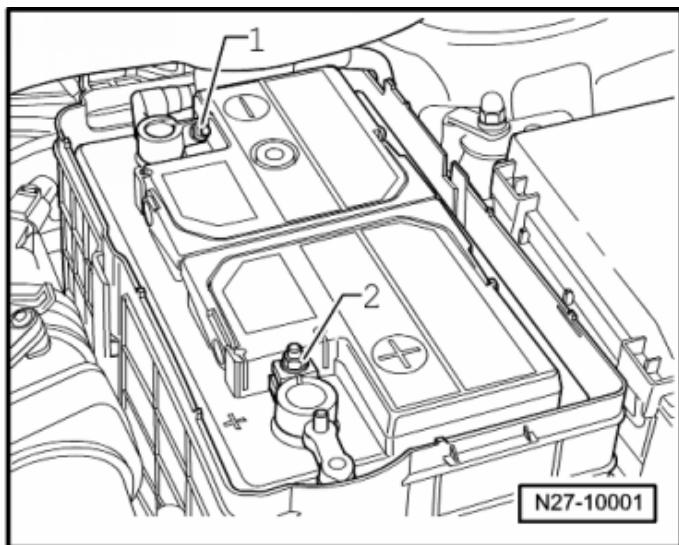

Section D – Airbag Removal

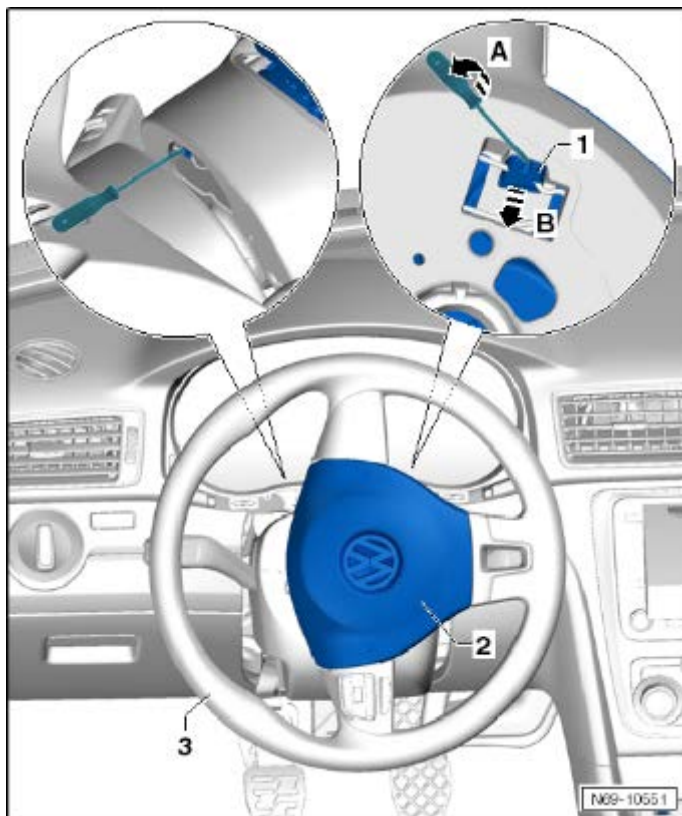

NOTE

Procedure illustrated is for a three spoke steering wheel. The procedure for a four spoke steering wheel is the same.

- Lower the steering wheel <3> as far as possible.
- Adjust steering wheel depth (reach) <3> so it is in the fully extended position.
- Turn the steering wheel <3> to the position illustrated.
- Insert a screwdriver all the way into the hole on the back of the steering wheel (approximately 8 mm).
- Turn the screwdriver toward the driver door <arrow A>. This will unlock the airbag unit <2> locking mechanism <1> in direction of <arrow>, on the right side of the steering wheel.
- Turn the steering wheel 180° and repeat the procedure on the opposite side.

NOTE

The screwdriver previously mentioned should be about 175 mm long and have a blade width of 7 mm.

WARNING

Before handling pyrotechnic components (for example, disconnecting the connector), the person handling it must “discharge static electricity”. This can be done by touching the door striker, for example.

- Turn the steering wheel back to its center position.
- Remove the airbag unit <2> from the steering wheel.
- Release the connector lock on the airbag connector <1> and remove it.
- Disconnect the connector <3> (if equipped).

WARNING

Set the airbag down so the logo on the impact cushion faces upward.

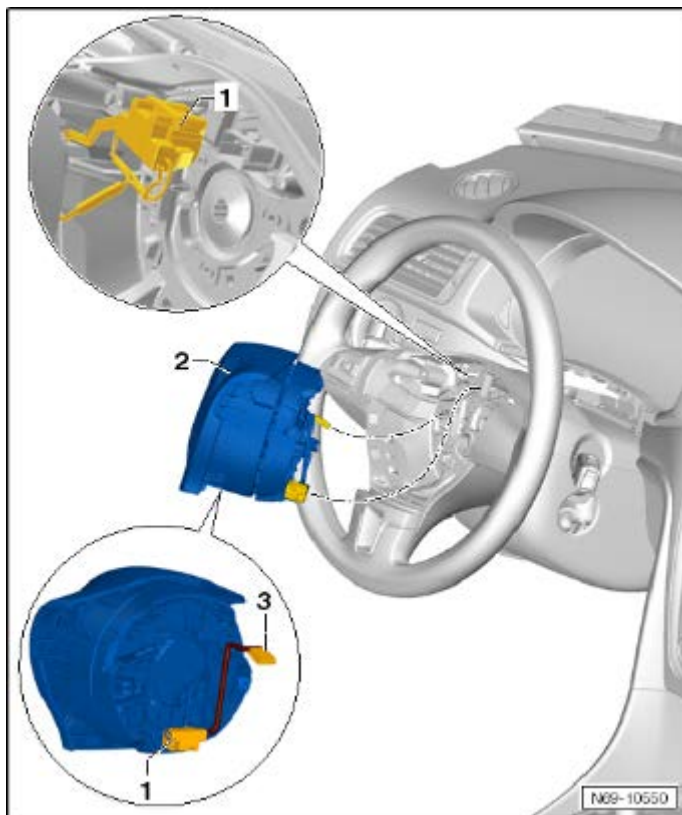

Section E – Inflator Replacement

⚠ WARNING

Risk of injury.

- People in the immediate vicinity of the workplace must be protected from possible noise and projectiles.
- Pyrotechnic components can trigger unintentionally.
- In the event of unintentional deployment:
 - Single-stage inflators: allow airbag to cool down completely. Wait at least 10 minutes before handling.
 - Two-stage inflators: wait for second airbag ignition. Allow airbag to cool down completely. Wait at least 10 minutes before handling.

⚠ WARNING

Risk of injury.

It is critical that a clean, uncongested work environment is utilized during the inflator replacement procedure. Extra tools, debris, etc... in the blast area of an airbag impose a danger in the event an airbag were to deploy. Ensure there are no loose components in the blast area of the airbag.



! NOTE

- Prior to beginning work, all parts and tools are to be placed on the ESD table mat.
- The workstation must be in the vicinity of the vehicle.

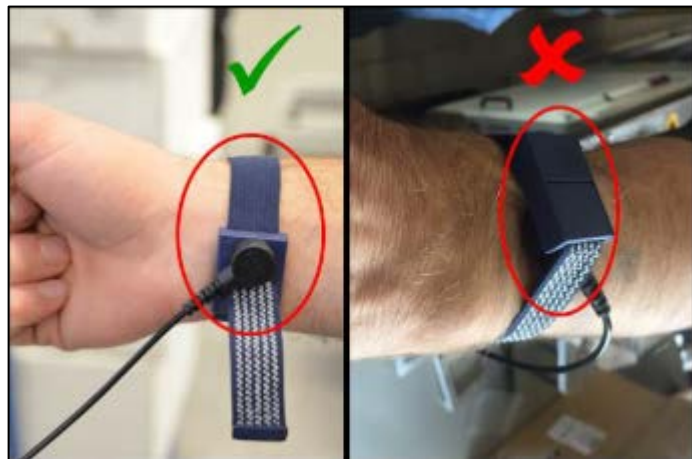

- Put the wrist strap from the ESD workplace on your wrist.

⚠ CAUTION

The white dots on the wrist strap must be against the skin.

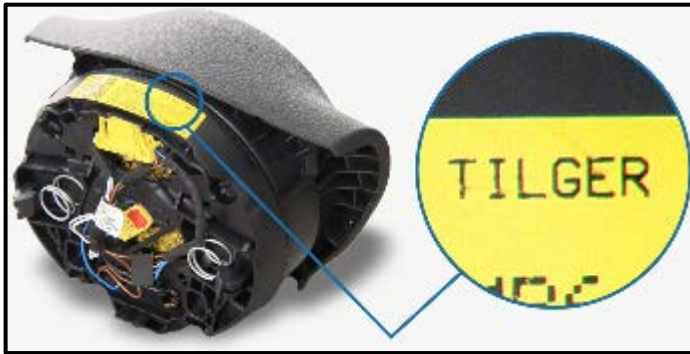

NOTE

- There are two types of inflator. One version is “with vibration absorption” and one is “without vibration absorption”.
- If the version “with vibration absorption” is installed, this can be identified by “**TILGER**” (vibration damper) on the label of the airbag module.
- If the version “without vibration absorption” is installed, there is **NO** lettering on the label of the airbag module

- Identify inflator version by criteria and proceed to the proper subsection.
 - Criteria N1: Renewing inflator, four spoke steering wheel, without vibration absorption: **Proceed to Subsection 1.**
 - Criteria T1: Renewing inflator, four spoke steering wheel, with vibration absorption: **Proceed to Subsection 2.**

Subsection 1 – Renewing inflator, four spoke steering wheel, without vibration absorption

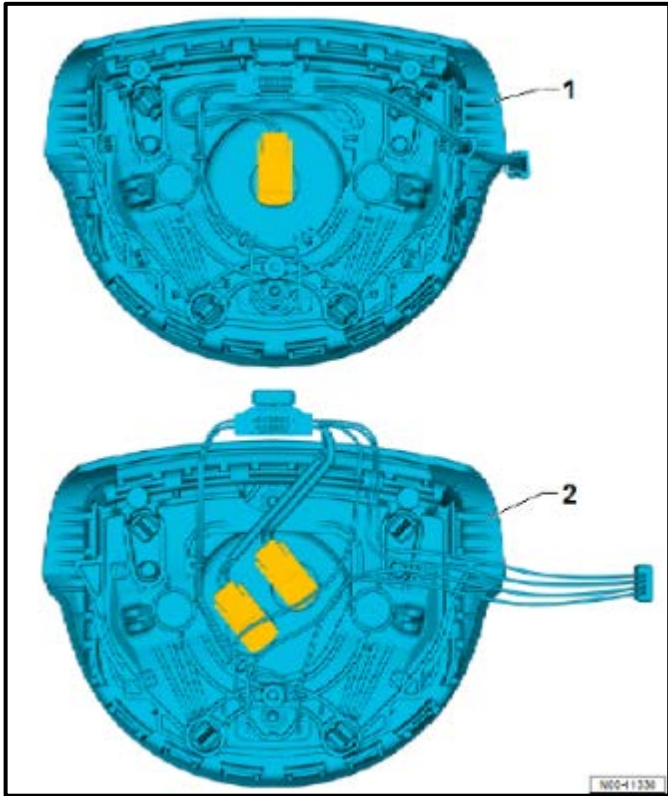

Removal Procedure:

NOTE

The inflator comes as a single-stage <1> or two-stage <2> version. The work steps for inflator renewal are the same.

The repair information in this document is intended for use only by skilled technicians who have the proper tools, equipment and training to correctly and safely maintain your vehicle. These procedures are not intended to be attempted by “do-it-yourselfers,” and you should not assume this document applies to your vehicle, or that your vehicle has the condition described. To determine whether this information applies, contact an authorized Volkswagen dealer. ©2018 Volkswagen Group of America, Inc. and Volkswagen Canada. All Rights Reserved.

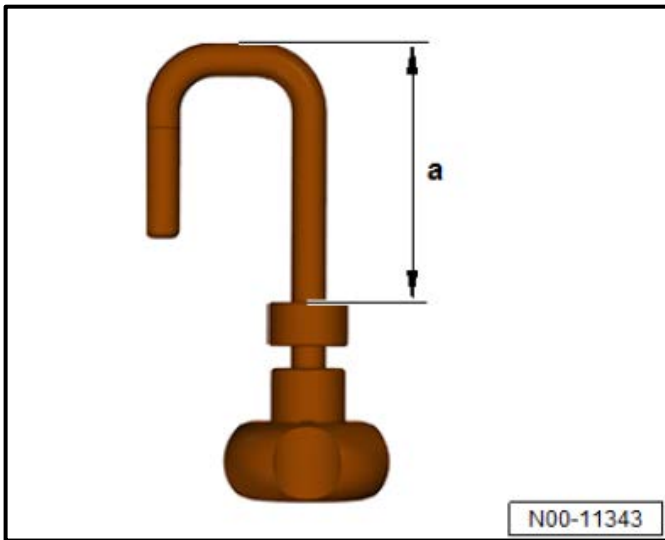

NOTE

- The four spoke steering wheel has two mounting points.
- Tighten mounting by hand to prevent damage.
- Adjust three knurled nuts of securing hooks to <dimension a> 50mm.

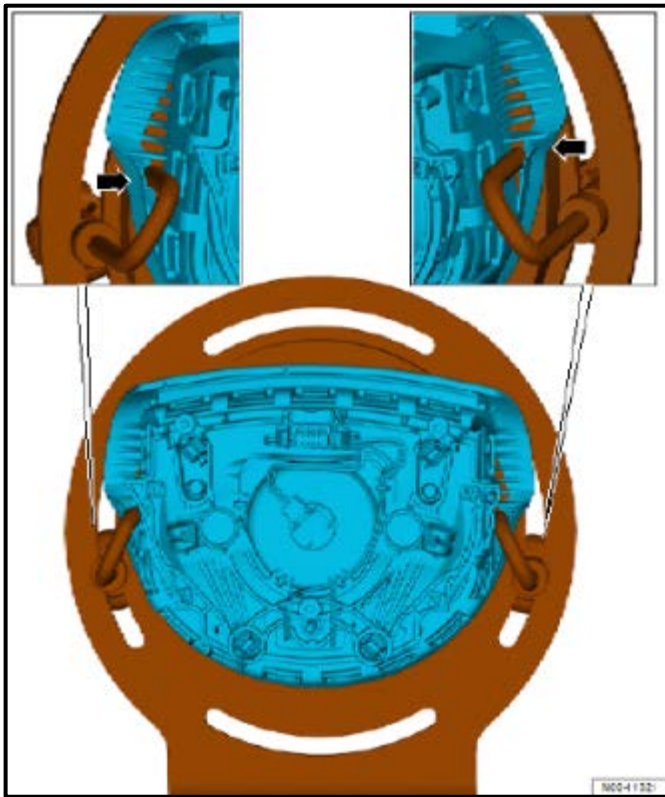

- Clamp airbag centrally in airbag support. Securing points on the sides <arrows> and parallel opposite each other.

NOTE

The clamps must be placed in the positions shown <arrows> to prevent damage to the airbag. Damage to the airbag is not covered under this action.

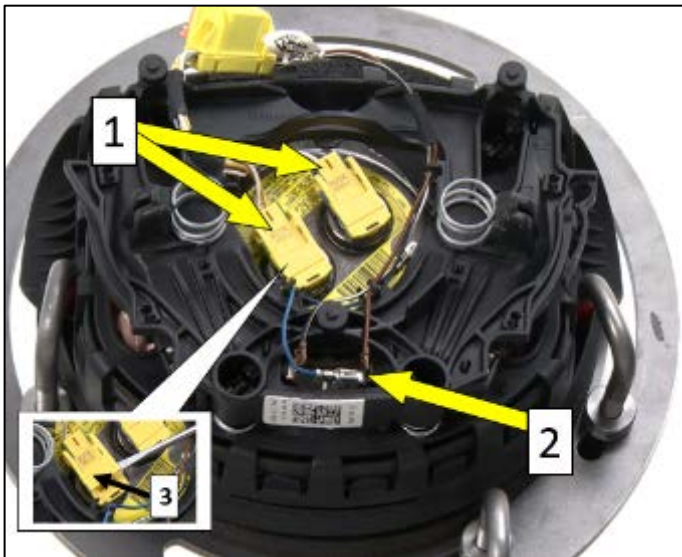

- Disengage connector locks <3> using a small flat bladed screwdriver.
- Remove connectors <1> using needle nose pliers.
- Remove ground cable <2>.

⚠ CAUTION

- Do not use a screwdriver to pry off connectors <1> or damage to the connectors could occur.
- Damage to the airbag connectors will not be covered under this action.

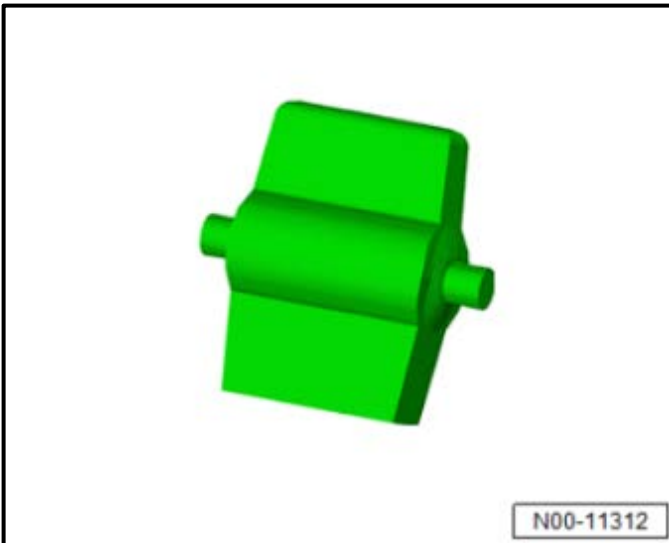

! NOTE

- The locking pins are to be reused.
- There may be instances in which short locking pins are fitted. These can be levered out with a small screwdriver.

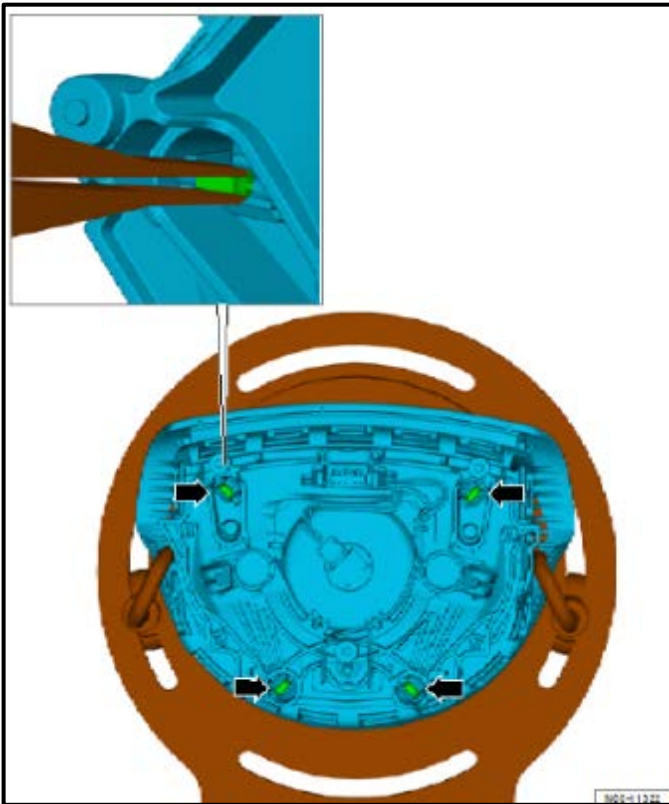

- Remove locking pins <arrows> for horn ring with aid of longnose pliers.

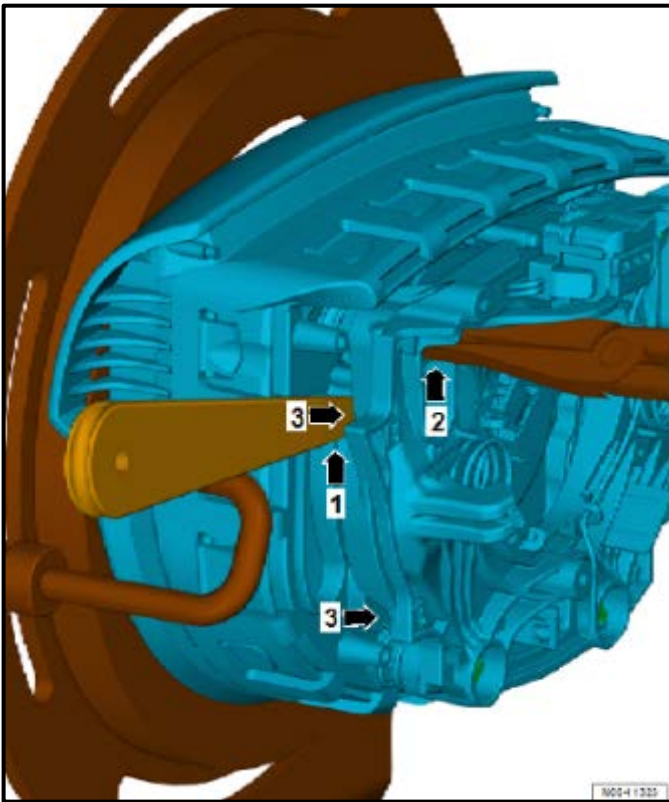

- Apply removal wedge -3409- between horn ring and inflator <1> and press together locking elements using longnose pliers <2>. Lever off horn ring at plastic lugs <3>.

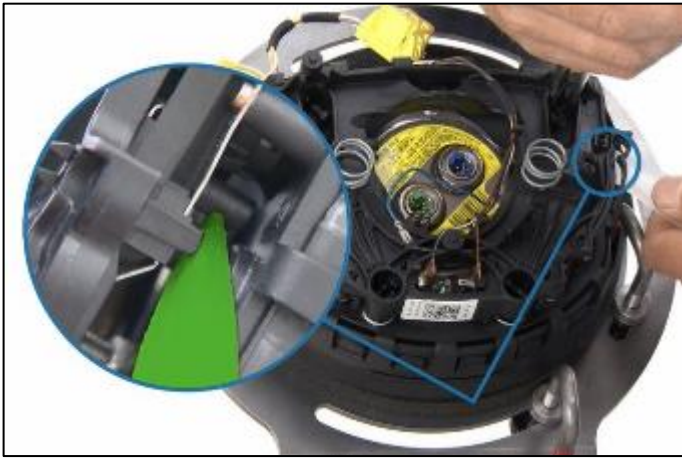

- Position the removal wedge -3409- on the plastic lugs to prevent damage to the conductor strip.
- Insert the removal wedge -3409- between the inflator and horn ring to prevent the horn ring from engaging again.
- Repeat work steps on other side.

⚠ CAUTION

Use extreme care when removing the horn ring. If horn ring is damaged during removal, airbag replacement will be necessary. Replacement of the airbag due to damage during horn ring removal will not be covered under this action.

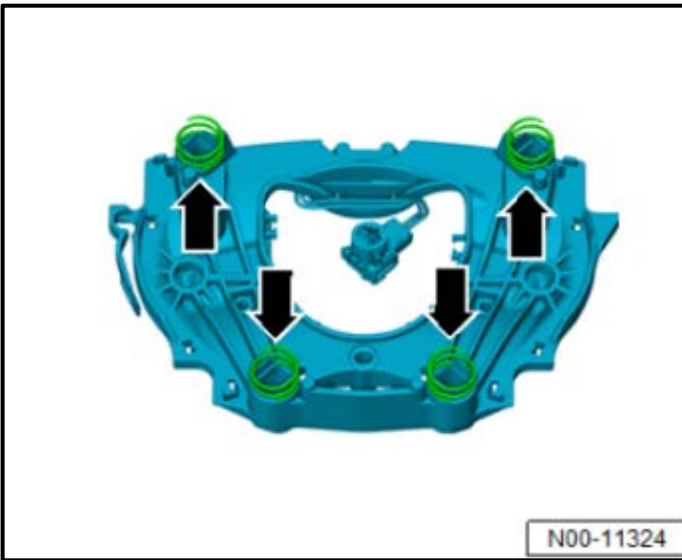

- Remove horn ring with springs <arrows>.

⚠ CAUTION

- When removing the horn ring, take care that the springs are not lost as they are not available separately.
- **ONE** replacement spring is included in the inflator kit in the event a spring is lost or damaged.
- If more than one spring is lost, replacement of the airbag is required. Replacement of the airbag is required if a spring is lost and is not covered under this action.

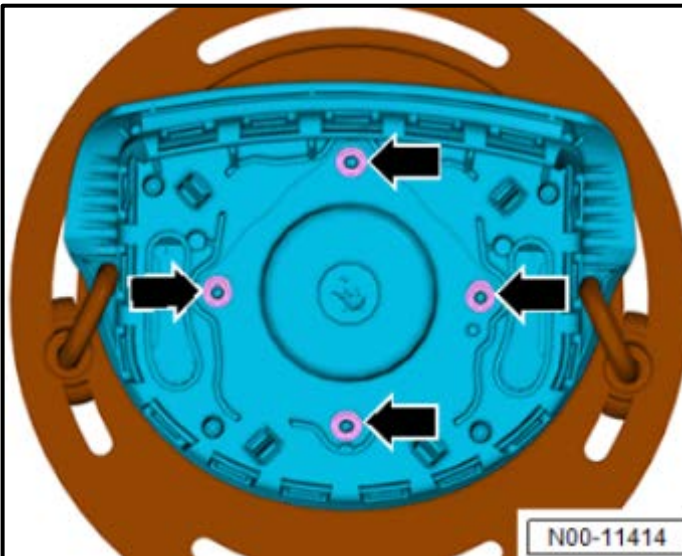

- Remove and discard nuts <arrows>.
- Remove the inflator and place in the original packaging.

Installation Procedure:

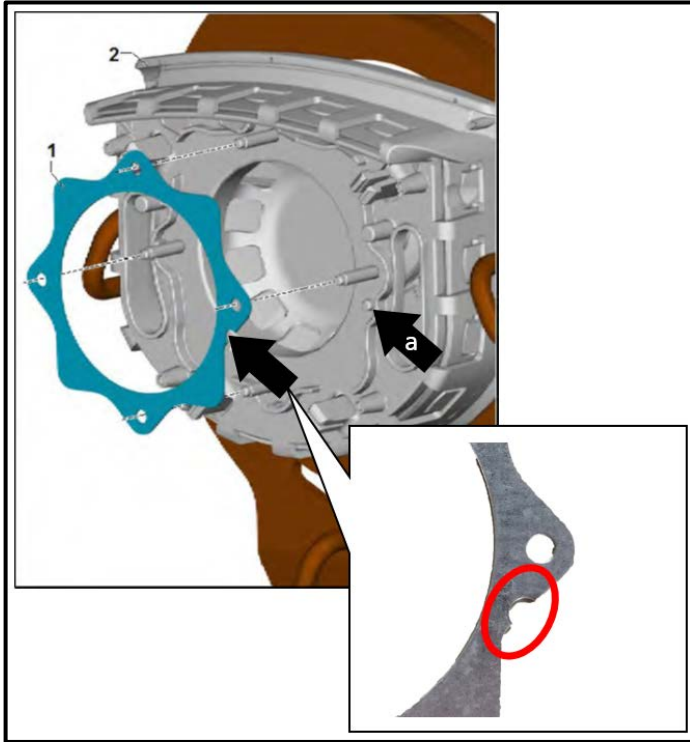

- Included in the replacement parts kit is a baffle plate. This must be used when installing the new inflator.
- Fit baffle plate <1> onto airbag <2> so that the notch <circle> lines up with the pin <arrow a> on the airbag.

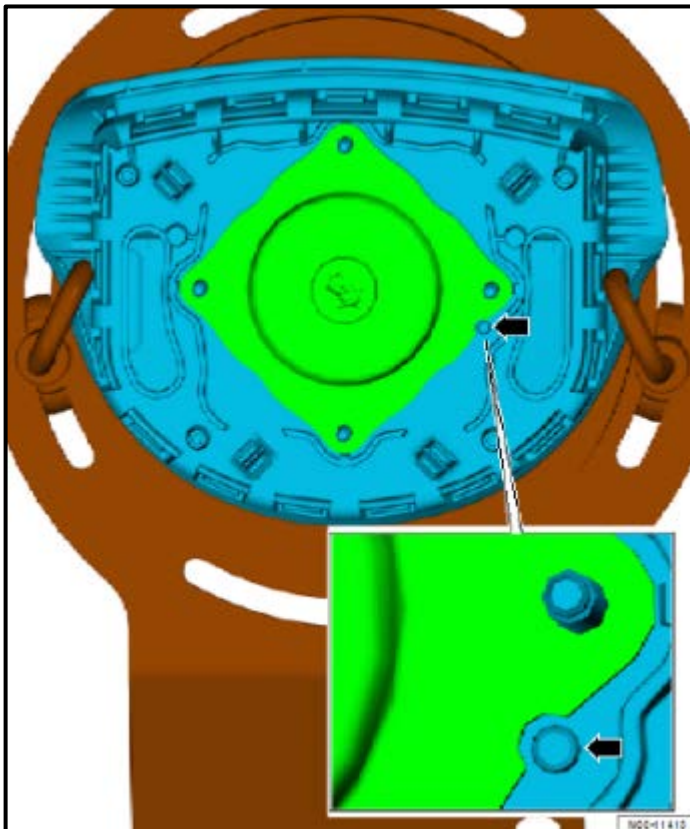

- Insert new inflator and check to ensure it is seated correctly. Note the recess <arrow>.

Criteria	Inflator Kit Part Number
N1	3C0 898 201 F

NOTE

In the event an airbag had previously been replaced, the replacement airbag may have an inflator WITH the vibration absorber. If this situation is encountered, the inflator WITH vibration absorption (part # 3C0898201G) MUST be installed:

- Repackage the previously scanned inflator and return to the parts department.
- Acquire the correct inflator (part # 3C0898201G) from the parts department.
- Scan the new inflator using the GFF test plan.
- Install the new inflator, following the **"Inflator versions WITH vibration absorption (Criteria T1)"** instructions.

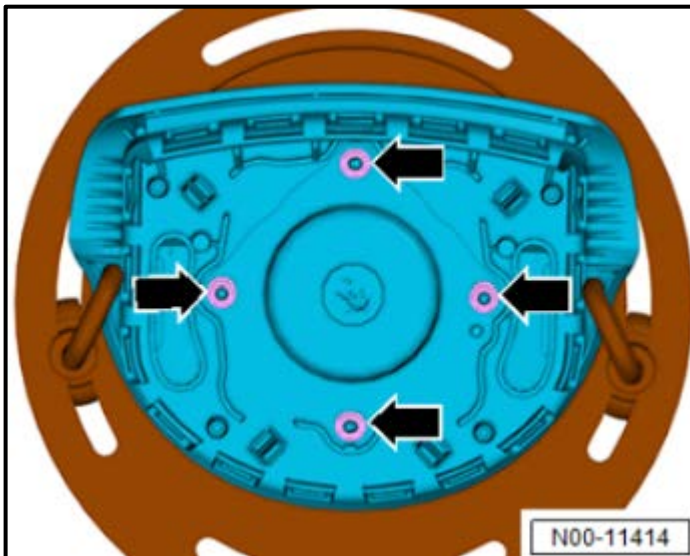

NOTE

The nuts are self-locking and must be replaced

- Install new nuts <arrows> and torque to 5 Nm ± 0.4 Nm.

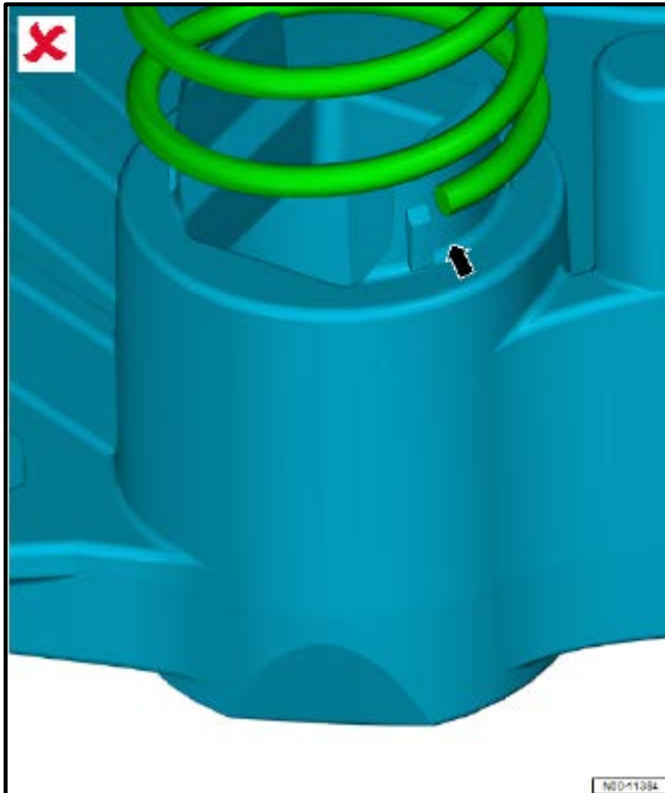

NOTE

- If one of the springs is damaged or has been lost, it can be replaced with a spring from the bag of spares included.
- Note the examples shown for reference of proper spring seating.

- Spring seated **incorrectly** <arrow>.

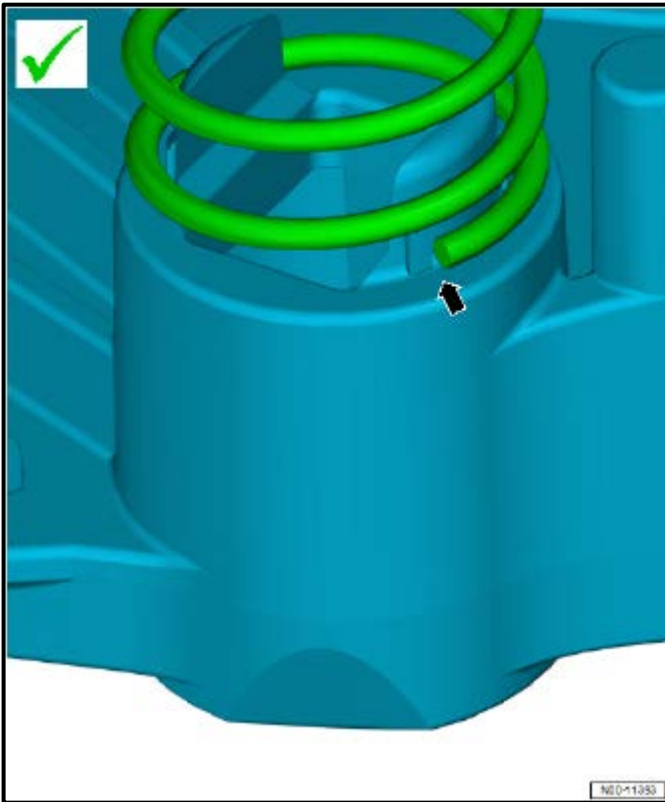

- Spring seated **correctly** <arrow>.

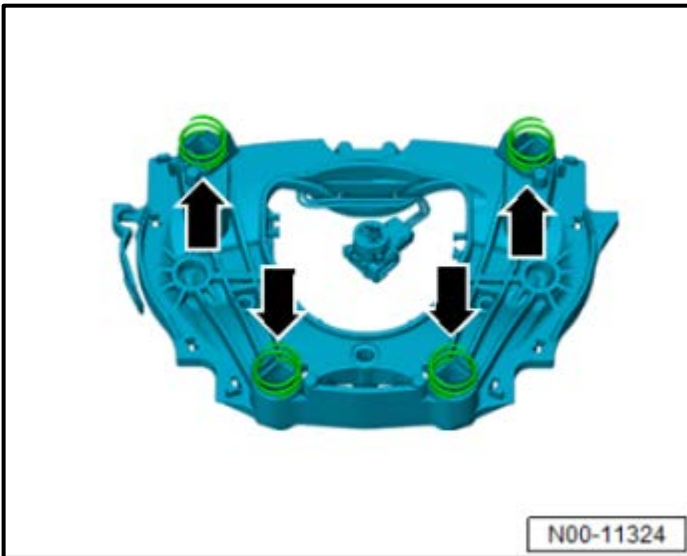

- Fit springs <arrows> for horn ring again if necessary.

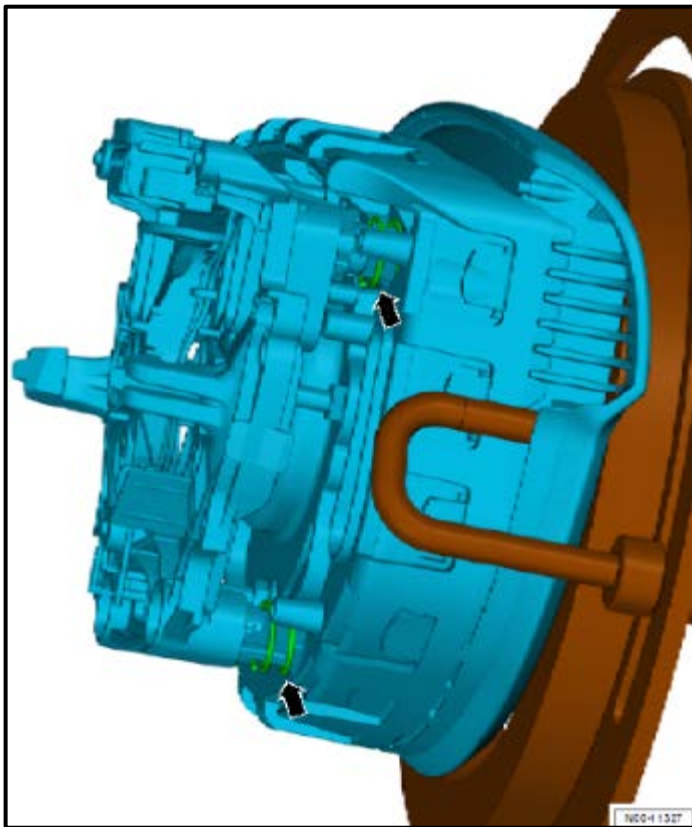

- Position horn ring with springs on securing clips and press firmly in place. Ensure that springs are seated correctly on both sides <arrows>.

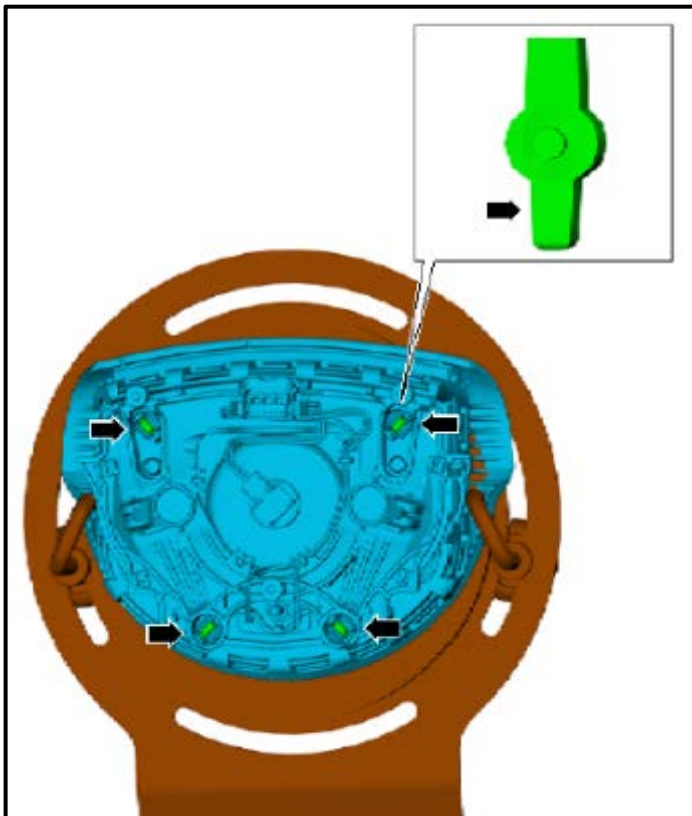

! NOTE

If a pin is damaged or has been lost, it can be replaced with a locking pin from the bag of spares included.

- Using long-nose pliers, insert four locking pins in retaining lugs with narrow side facing downwards <arrow in magnification>. Pins must engage audibly.

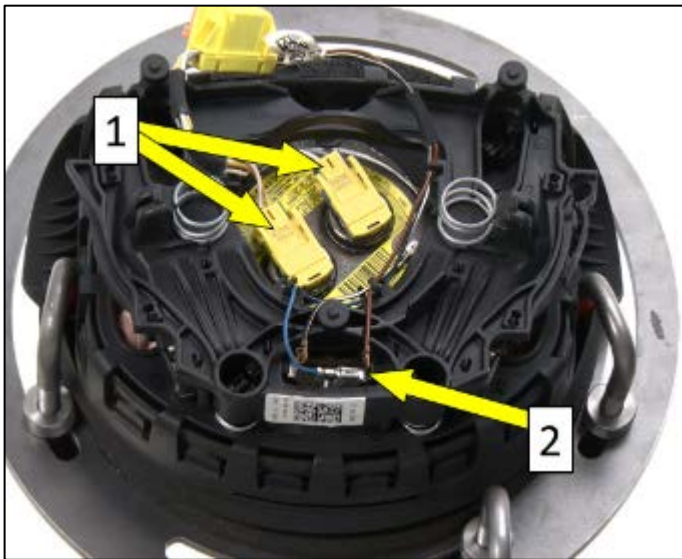

- Connect central connector(s) <1> on inflator.
- Press central connector lock(s) in until fully locked.
- Connect ground cable <2>.

Continue to Section F.

Subsection 2 – Renewing inflator, four spoke steering wheel, with vibration absorption

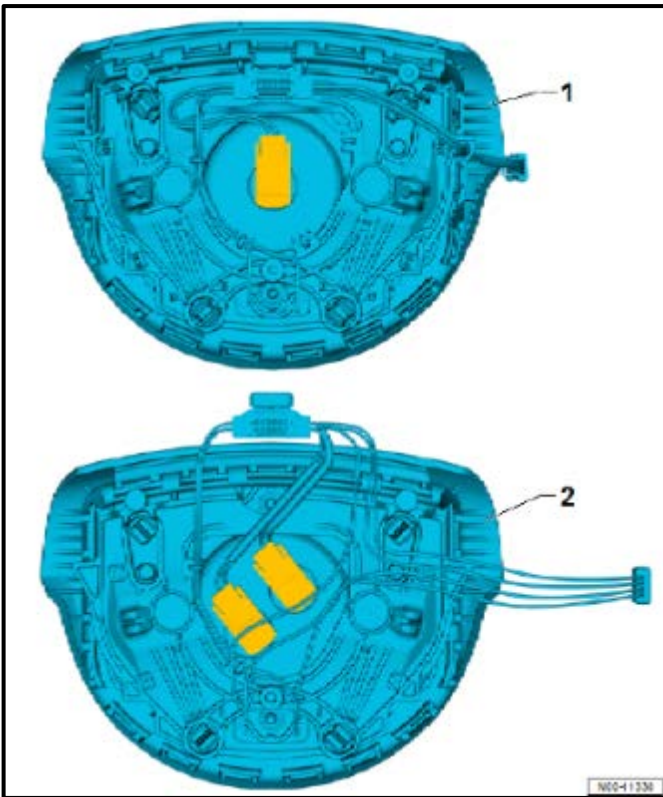

Removal Procedure:

! NOTE	
<ul style="list-style-type: none"> • The inflator comes as a single-stage <1> or two-stage <2> version. The work steps for inflator renewal are the same. • Tighten mounting by hand to prevent damage. 	

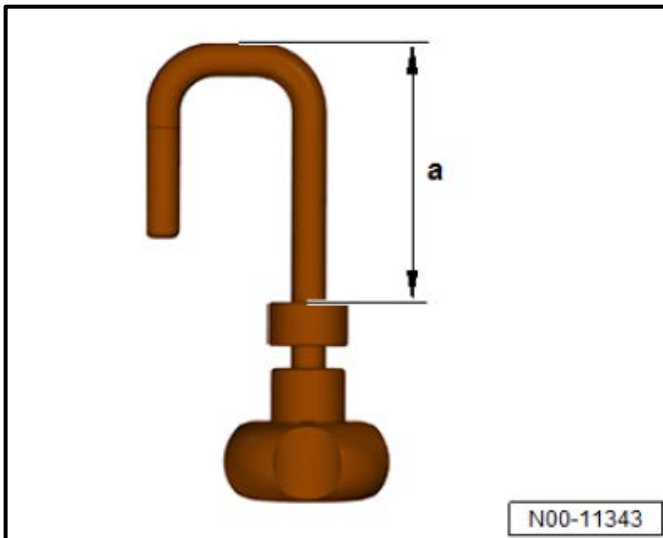

! NOTE

- The four spoke steering wheel has two mounting points.
- Tighten mounting by hand to prevent damage.
- Adjust three knurled nuts of securing hooks to <dimension a> 50mm.

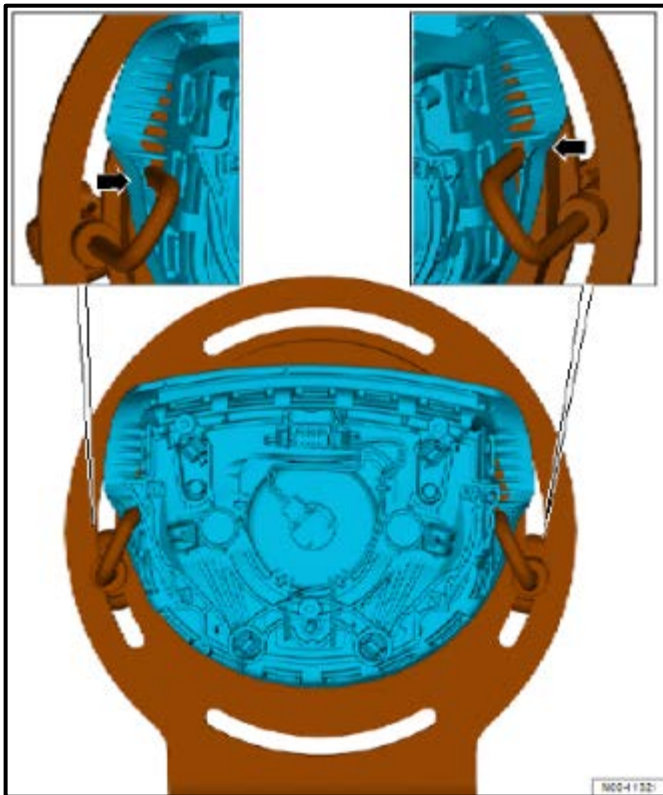

- Clamp airbag centrally in airbag support. Securing points on the sides <arrows> and parallel opposite each other.

! NOTE

The clamps must be placed in the positions shown <arrows> to prevent damage to the airbag. Damage to the airbag is not covered under this action.

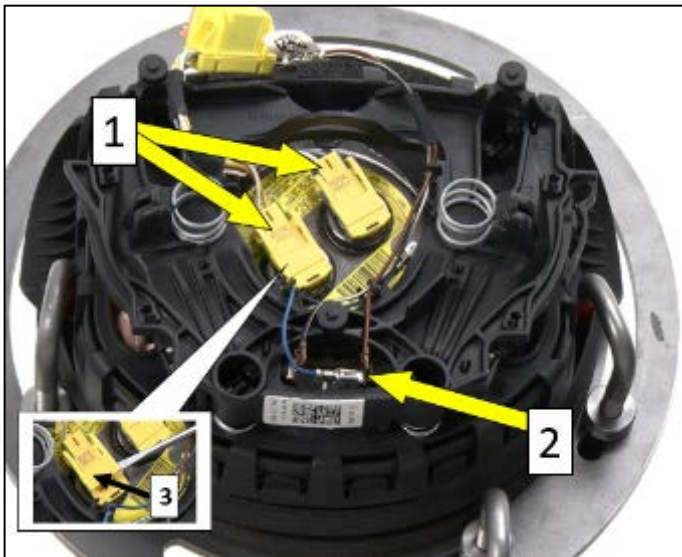

- Disengage connector locks <3> using a small flat bladed screwdriver.
- Remove connectors <1> using needle nose pliers.
- Remove ground cable <2>.

⚠ CAUTION

- Do not use a screwdriver to pry off connector <1> or damage to the connector could occur.
- Damage to the airbag connectors will not be covered under this action.

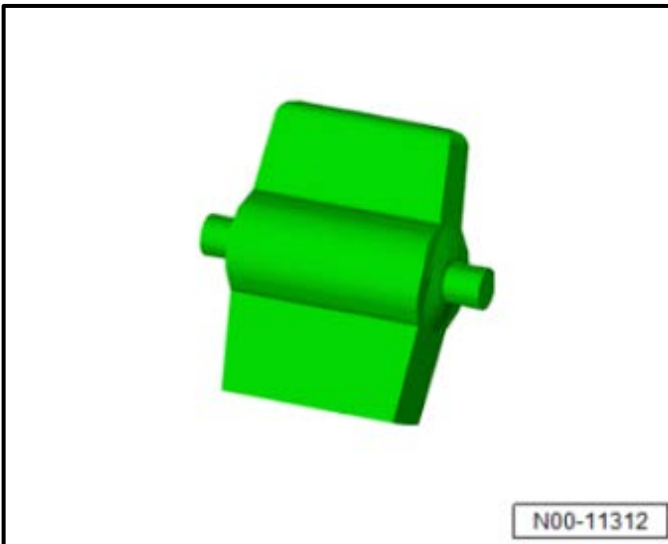

! NOTE

- The locking pins are to be reused.
- There may be instances in which short locking pins are fitted. These can be levered out with a small screwdriver.

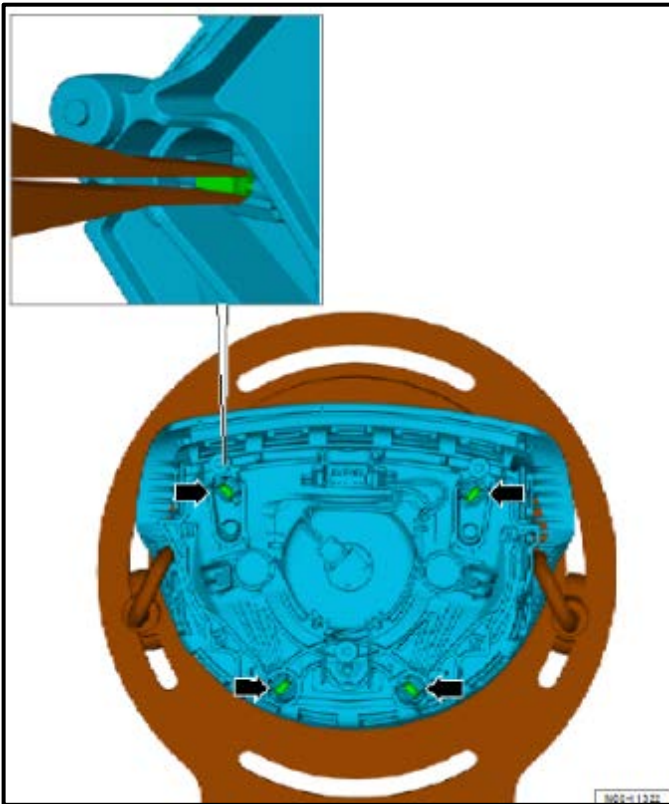

- Remove locking pins <arrows> for horn ring with aid of longnose pliers.

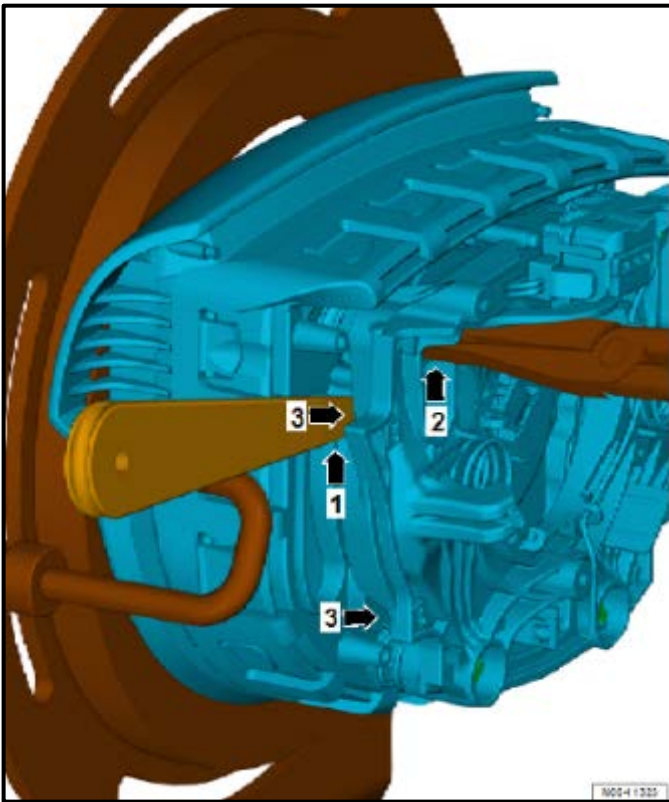

- Apply removal wedge -3409- between horn ring and inflator <1> and press together locking elements using longnose pliers <2>. Lever off horn ring at plastic lugs <3>.

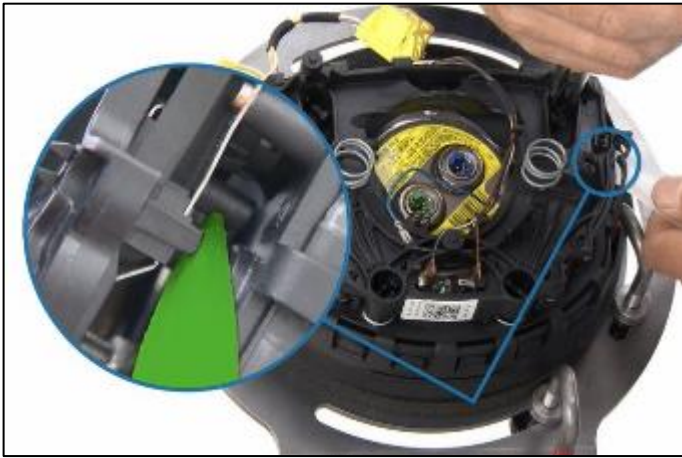

- Position the removal wedge -3409- on the plastic lugs to prevent damage to the conductor strip.
- Insert the removal wedge -3409- between the inflator and horn ring to prevent the horn ring from engaging again.
- Repeat work steps on other side.

⚠ CAUTION

Use extreme care when removing the horn ring. If horn ring is damaged during removal, airbag replacement will be necessary. Replacement of the airbag due to damage during horn ring removal will not be covered under this action.

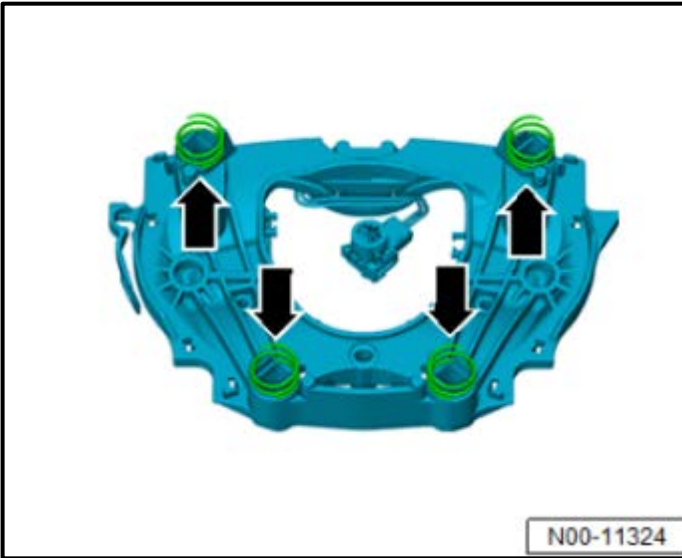

- Remove horn ring with springs <arrows>.

⚠ CAUTION

- When removing the horn ring, take care that the springs are not lost as they are not available separately.
- **ONE** replacement spring is included in the inflator kit in the event a spring is lost or damaged.
- If more than one spring is lost, replacement of the airbag is required. Replacement of the airbag is required if a spring is lost and is not covered under this action.

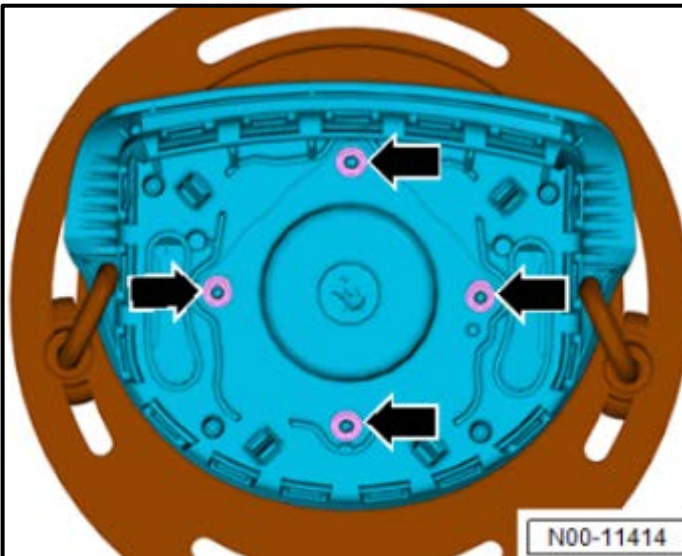

- Remove and discard nuts <arrows>.
- Remove the inflator and place in the original packaging.

Installation Procedure:

- Insert new inflator and check to ensure it is seated correctly. Note the recess <arrow>.

Criteria	Inflator Kit Part Number
T1	3C0 898 201 G

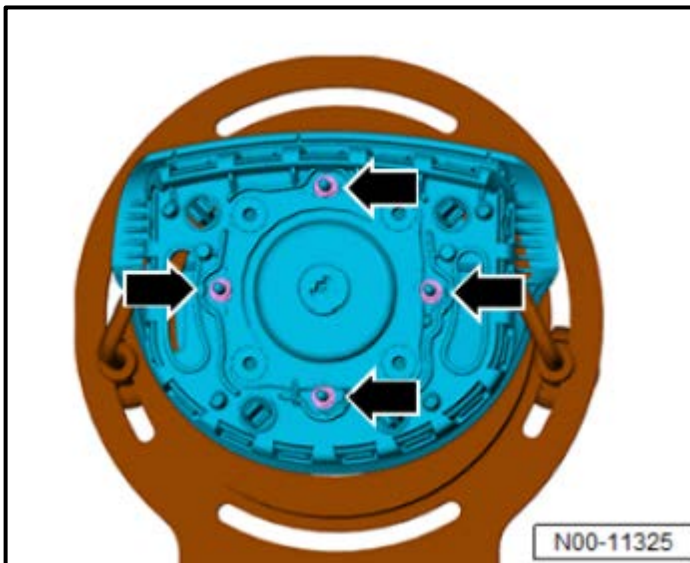
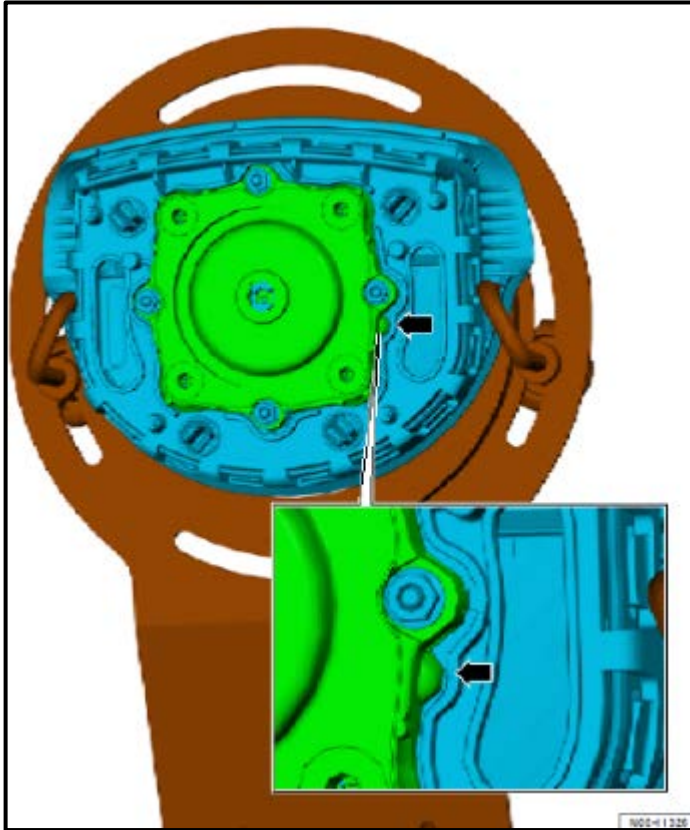

! NOTE

The nuts are self-locking and must be replaced.

- Install new nuts <arrows> and torque to 5 Nm \pm 0.4 Nm.

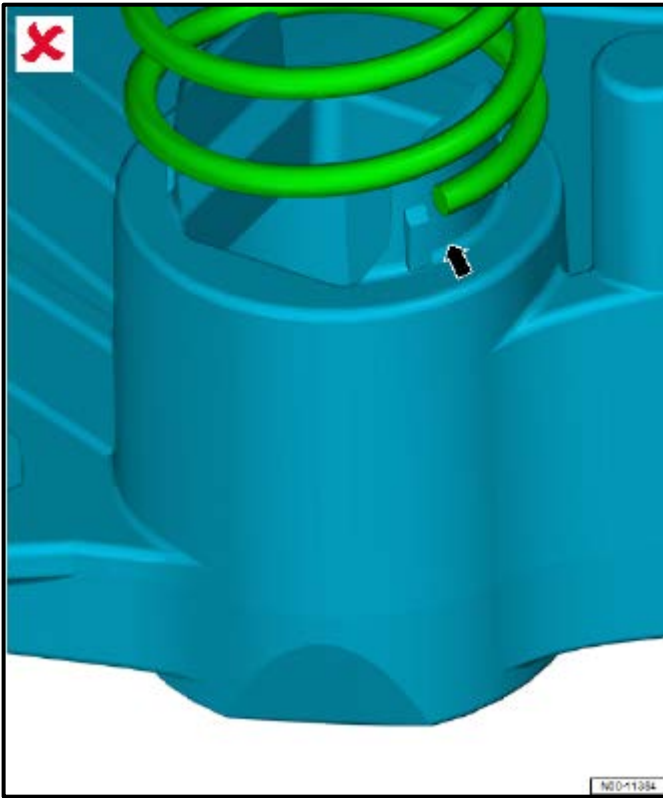

NOTE

- If one of the springs is damaged or has been lost, it can be replaced with a spring from the bag of spares included.
- Note the examples shown for reference of proper spring seating.

- Spring seated **incorrectly** <arrow>.

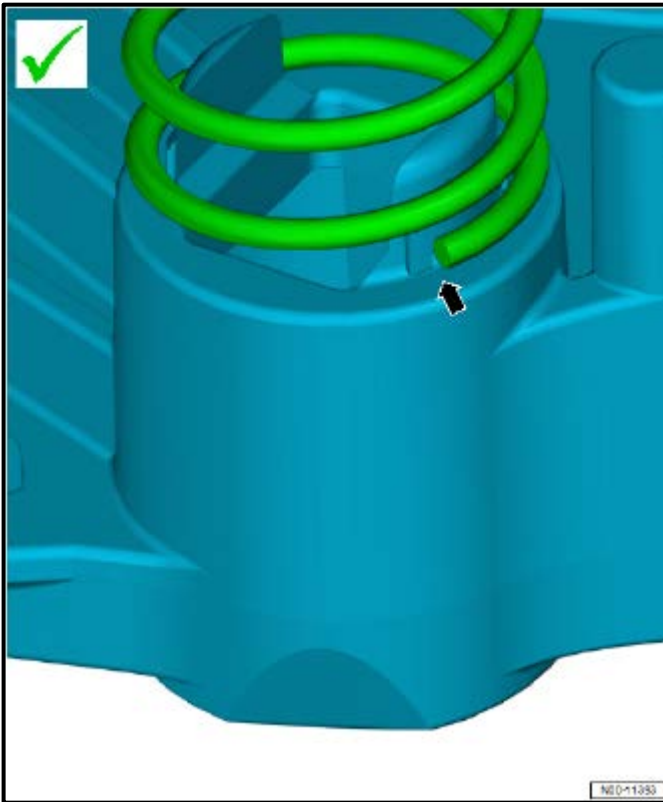

- Spring seated **correctly** <arrow>.

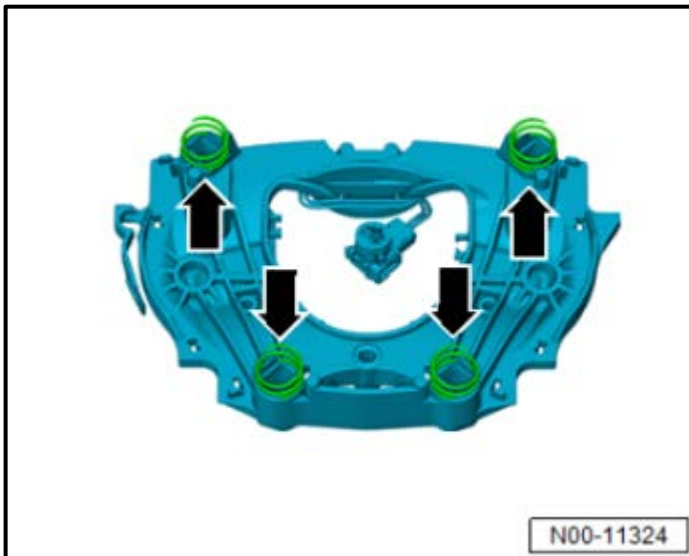

- Fit springs <arrows> for horn ring again if necessary.

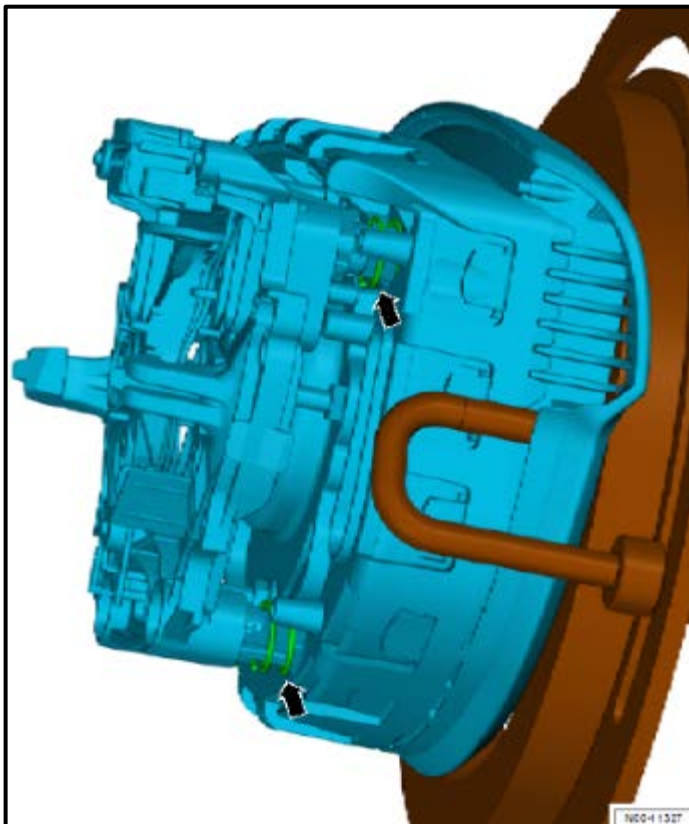

- Position horn ring with springs on securing clips and press firmly in place. Ensure that springs are seated correctly on both sides <arrows>.

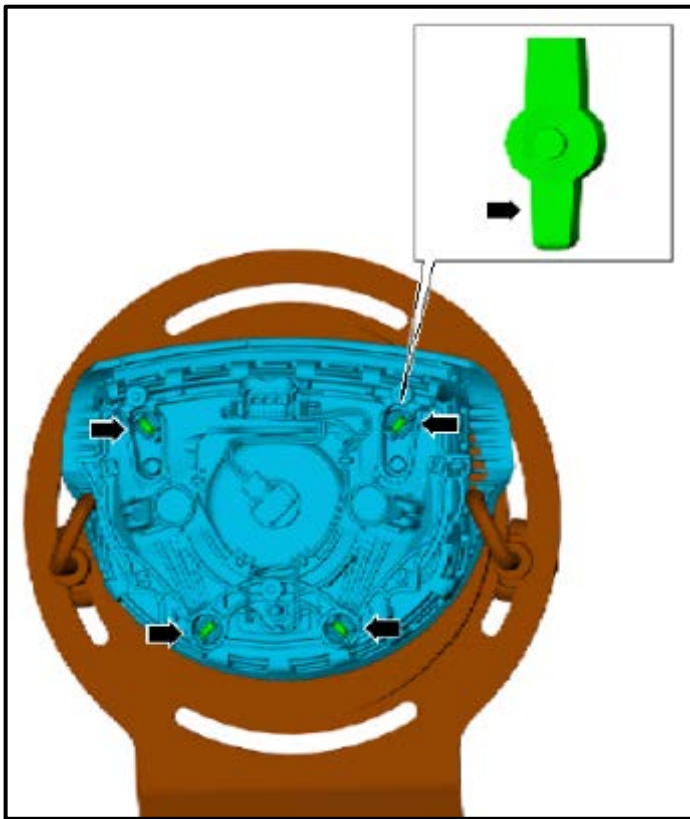

NOTE

If a pin is damaged or has been lost, it can be replaced with a locking pin from the bag of spares included.

- Using long-nose pliers, insert four locking pins in retaining lugs with narrow side facing downwards <arrow in magnification>. Pins must engage audibly.

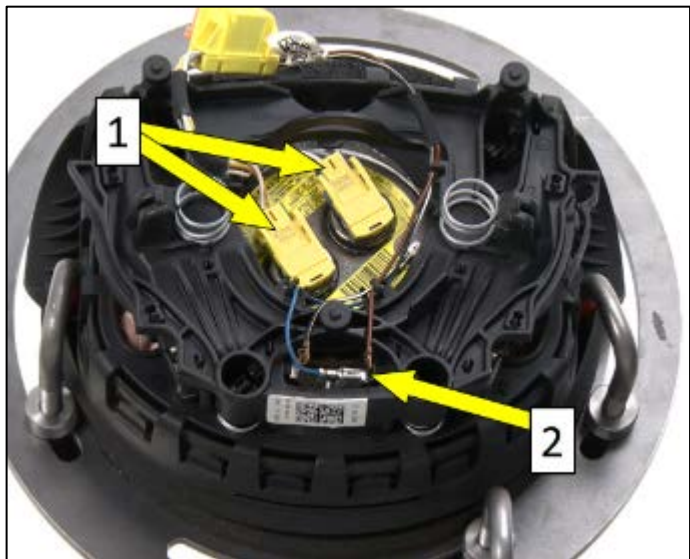

- Connect central connector(s) <1> on inflator.
- Press central connector lock(s) in until fully locked.
- Connect ground cable <2>.

Continue to Section F.

Section F – Airbag Installation

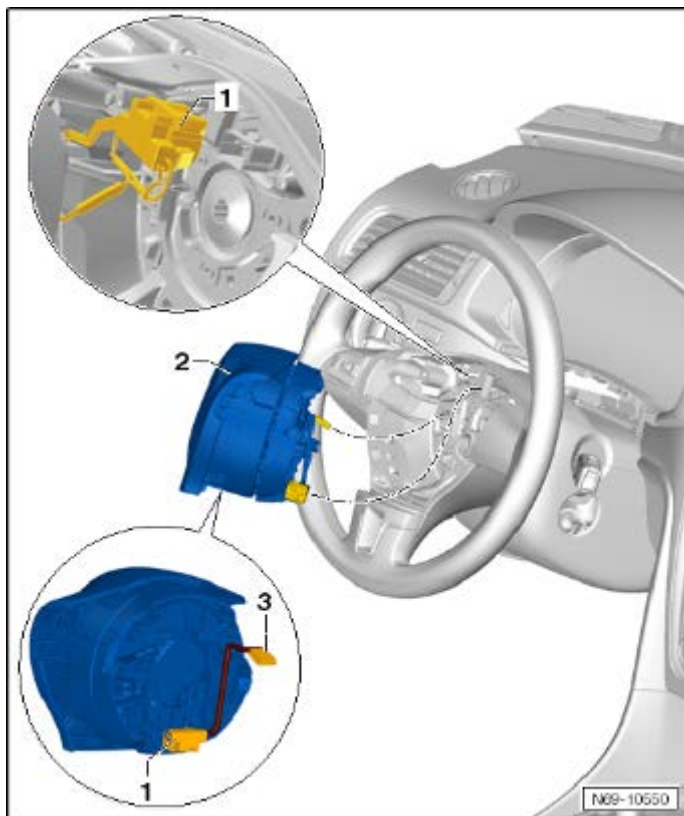

⚠ WARNING

- The battery must be disconnected before installing the airbag back into the vehicle.
- Before handling pyrotechnic components (for example, disconnecting the connector), the person handling it must “discharge static electricity”. This can be done by touching the door striker, for example.

- Connect the connector <1>. The connector must click into place.
- Press the connector lock on the connector <1>.
- Connect the connector <3> (if equipped).
- Insert the airbag unit <2> into the steering wheel but do not press on it.

ⓘ NOTE

Procedure illustrated is for a three spoke steering wheel. The procedure for a four spoke steering wheel is the same.

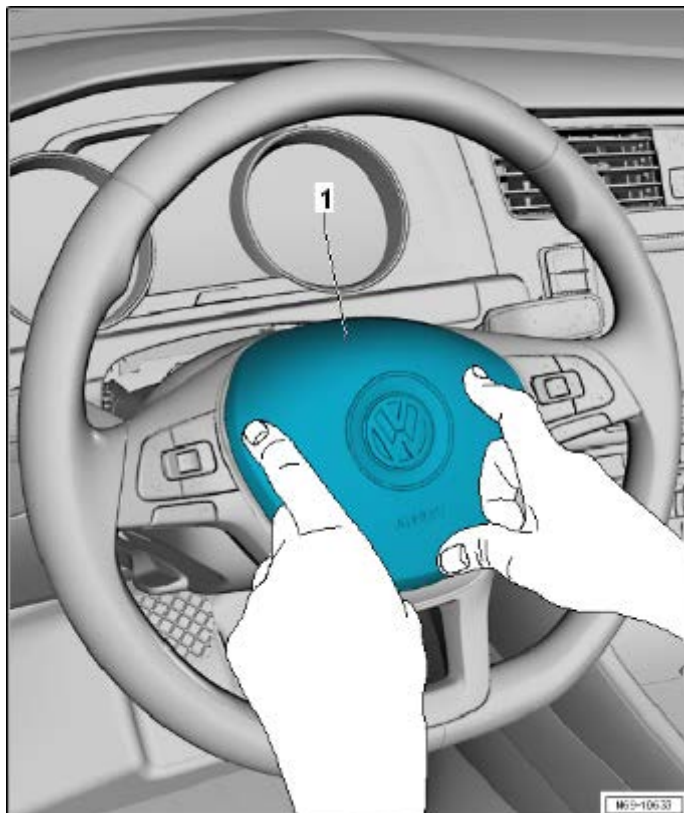

- Press on the edge of the airbag unit <1> with both hands until it locks into place.
- Gently pull on the airbag unit to make sure the airbag unit is secured correctly at all three attachment points in the steering wheel.

Continue to Section G.

Section G – Battery Reconnect

TIP

The engine may not start after reconnecting battery. This condition should be resolved by following these steps:

1. Remove the key from the vehicle.
2. Open and close the driver's door.
3. Lock then unlock the vehicle using the remote.
4. Insert the key and the vehicle should now start.

WARNING

Ignition must be **ON** when connecting battery. If pyrotechnic components (e.g. airbag, belt tensioner) are not repaired correctly, they may deploy unintentionally after connecting battery. There must not be anyone inside the vehicle when connecting the battery.

- Connect the battery ground cable terminal by hand to the battery negative terminal.
- Torque the nut <1> to 6 Nm.

NOTE

After connecting the battery and switching on the ignition, the ASR/ESP Control Lamp -K155- and Electromechanical Power Steering Indicator Lamp light up continuously. The indicator lamps switch off automatically after driving straight ahead at 15 to 20 km/h. This activates Steering Angle Sensor -G85-.

- Close the cover <1>.
- Cycle the ignition off and back on.
- Bring driver seat to an upright position.
- Store previously recorded radio presets (if necessary).
- Set clock to local time.
- Activate the power window regulator one-touch up/down function.
- Check the DTC memories of all the control units and erase under-voltage faults if necessary.
- After completing repairs, verify the horn is operational.

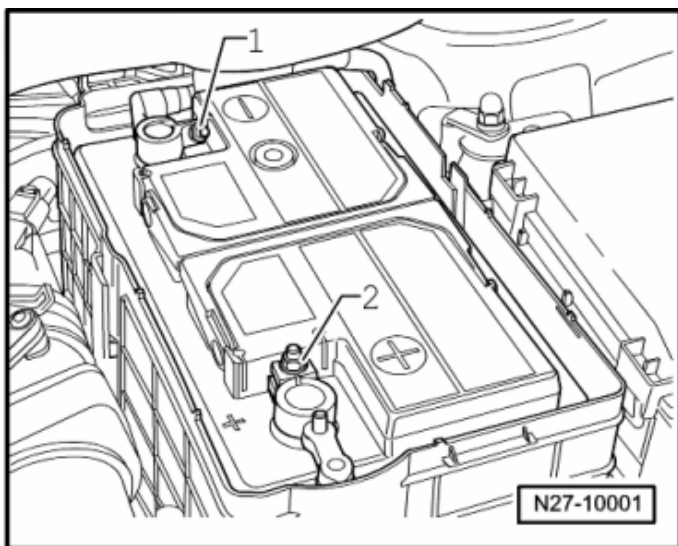

 **NOTE**

Diagnosis and repair of an inoperable horn, before or after inflator replacement, will not be covered under this campaign.

Proceed to Section H.

Section H – Campaign Completion Label

Install Campaign Completion Label

- Fill out and affix Campaign Completion Label, part number CAMP 010 000, next to the vehicle emission control information label.

 **TIP**

Ensure Campaign Completion Label does not cover any existing label(s).

Repair is Complete, Proceed to Appendix B
(Mandatory Takata Part Return Process).

WARNING

General Safety Precautions when Working with Pyrotechnic Components:

- Pyrotechnic components always contain propellant that generates a gas during combustion. In some components, there is also a supply of pressurized gas to ensure this gas is generated
- This pressurized gas is stored under high pressure in a compressed gas container. Pyrotechnic components are triggered by electrical/mechanical igniters.
- Only trained personnel should perform testing, assembly and servicing work. Airbags do not have a replacement interval.
- Never check with test lamps, voltmeter or ohmmeters.
- Only check pyrotechnic components when they are installed in the vehicle using vehicle diagnosis, testing and information systems approved by the manufacturer.
- When working on pyrotechnic components and the airbag control module, disconnect the battery ground strap while the ignition is switched on. Then cover the negative terminal.
- Wait 10 seconds after disconnecting the battery.
- The ignition must be SWITCHED ON when connecting the battery. There should not be anyone inside the vehicle when doing this.
- Exception: vehicles with batteries in the passenger compartment. In this case, stay outside the range of the airbags and seat belts.
- Wash your hands after touching ignited pyrotechnic components from the restraint system.
- Do not open or repair pyrotechnic components. Use only new components to reduce the risk of injury.
- Do not install pyrotechnic components that have fallen onto a hard surface or show signs of damage.
- Discharge static electricity before handling pyrotechnic components, for example before disconnecting the electrical connector. This can be done by touching grounded metal objects such as the door striker pin.
- Install pyrotechnic components immediately after removing them from their transport packaging. If you must stop working, store the pyrotechnic component in its original transport packaging.
- Do not leave pyrotechnic components lying in the open unattended.
- Do not treat pyrotechnic components with grease, cleaning solutions or similar products.
- Do not expose pyrotechnic components to temperatures above 100 °C, even for brief periods of time.
- People in the immediate vicinity of the workplace must be protected from possible noise and projectiles.
- Pyrotechnic components can trigger unintentionally.
- In the event of unintentional deployment:
 - Single-stage inflators: allow airbag to cool down completely. Wait at least 10 minutes before handling.
 - Two-stage inflators: wait for second airbag ignition. Allow airbag to cool down completely. Wait at least 10 minutes before handling.

Appendix B – Mandatory Takata Parts Return Process

NOTE

NOTE: International (including Mexico and Canada), Hawaii, Alaska, Puerto Rico, and US Virgin Islands dealers **CANNOT** follow below shipping instructions. Instead, dealerships in these locations **MUST** contact the following Takata/Menlo USA representative directly for shipping instructions: Miguel Prigadaa – Tel #: 210-250-5078 or Email: MLGTakataRestrains_International@menloworldwide.com. Or they can email the attached form to Menlo/XPO, (email is in the form) & they will make arrangements with Crane Worldwide to arrange pick up. As info, both emails go to the same international people that arrange the freight. MLGTakataRestrains_International@menloworldwide.com; SCTakataRestrains_International@XPO.com

NOTE: For Continental US 48 State dealerships, please follow steps 1-8 below.

1. Shipping Documents

a) Box Label

- Supplied with each Kit
- To be affixed to each box



b) Over-pack Label

- To be supplied by XPO
- To be affixed to the outside of each pallet



c) Bill of Lading

- To be supplied by XPO.
- Print 2 copies: 1 for Dealer Records, 1 for LTL Driver



d) ERG Document

- To be supplied by XPO.
- To be provide by the Dealer to the LTL Driver for each shipment



5. Shipping Instructions – Prepare the Pallet

- Accumulate and palletize Kits
- Arrange Kits on Pallet as pictured here
 - 20 boxes per row/layer (5x4)
 - 10 rows/layers per pallet (200 boxes)
- Shrink-wrap Kits to Pallet
- Affix Over-pack Label on (1) side of Pallet (Not on Top)



6. Shipping Instructions – Schedule LTL Pickup

- Upon Accumulating 200 kits (1 Over-pack/Pallet) Minimum
 - Call XPO at 1-888-708-5712
 - If 200 Kits have not been accumulated in 30 days, please call XPO for direction
- Have the following Information Available
 - Dealer #
 - Quantity of Over-packs/Pallets
 - Quantity of Passenger Inflator Kits on each Pallet
 - Email Address where shipping Documentation can be received

2. Packing Instructions

a) Confirm box is in acceptable condition. If a new box is needed, follow the New Box instructions located In Box 8 of this page.

b) Place the un-deployed air bag inflator in the "cradle" of the box insert.



3. Closure Instructions

a) Close the top box flap, per box closure instructions located on front panel of box.

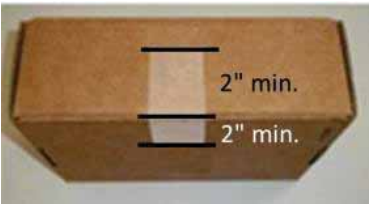

4. Shipping Instructions - Label each Box

a) New Labels will begin shipping in each kit starting mid June, 2015

1. VW/Audi Inflator Kit will contain this two-part label.
2. Peel off 'Ship To' Label.
3. Affix Label to Box. Do not cover up Class 9 Marking.

7. Shipping Instructions – Ship

- Give 1 Copy of BOL and 1 Copy of ERG to Driver
- Retain 1 Copy of BOL for Dealership records and archive for 2 Years

8. Requesting a New Box / Shipping Labels

If a new box or replacement shipping labels are needed, please contact the representative listed below by phone or email to request replacement materials.

Primary Contact: XPO Customer service Rep- Tel #: 210-250-5079

E-Mail: SCFieldAction.14305@xpo.com

To help expedite your request, please be prepared to provide the following information:

- Serial number on the original box
- What Type of shipping material needed
 - Replacement Box
 - Two Part Return Label
 - Bill of Lading
 - ERG Form
- Dealer Shipping Information
 - Contact name
 - Dealer Address
 - Phone Number



U.S. Only

NOTE

Crane Worldwide Logistics will arrange pick-up of all return Takata product. Dealers **MUST** follow directions on attached sign up form and pick-up request instructions.

If you have any issues, questions or require additional information regarding shipping, contact the following Takata/Menlo USA representative directly:

Miguel Prigadaa

Tel number: 210-250-5078

Email: MLGTakataRestrains_International@menlowworldwide.com

NOTE: For reference purposes only, see steps 1-8 below.

Canadian Dealers - Do Not Contact XPO

Gillian Guilbert, Campaign Specialist

Tel number: (905) 428-4601

E-mail: Warranty.campaigns@vw.ca ou Warranty.campaigns@audi.ca

1. Shipping Documents

a) Over-pack Label

- To be supplied by carrier
- To be affixed to the outside of each pallet

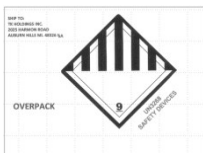

b) Bill of Lading (BOL)

- To be supplied by carrier
- Print 2 copies: 1 for Dealer Records, 1 for truck Driver



c) ERG Document

- To be supplied by carrier
- To be provided by the Dealer to the truck Driver for each shipment



2. Packing Instructions

a) Confirm box is in acceptable condition.

b) Place the un-deployed air bag inflator in the "cradle" of the box insert.



3. Closure Instructions

a) Close the top box flap, per box closure instructions located on front panel of box.



4. Shipping Instructions - Label each Box

a) This step is **only** necessary if label is included in box.

- VW/Audi Inflator Kit will contain this two-part label:
- Peel off 'Ship To' Label.
- Affix Label to Box. Do not cover up Class 9 Marking.

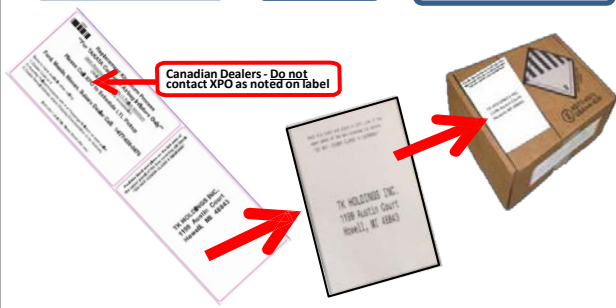

5. Shipping Instructions – Prepare the Pallet

- Accumulate and palletize Kits
- Arrange Kits on Pallet as pictured here
 - 20 boxes per row/layer (5x4)
 - 10 rows/layers per pallet (200 boxes MAX)
- Shrink-wrap Kits to Pallet
- Affix Over-pack Label on (1) side of Pallet (Not on Top)
- Kits **cannot** be shipped in a master carton. If not enough to palletize, kits can be returned in their individual Boxes with dangerous goods markings visible. Select "via small package" when shipping individually



6. Shipping Instructions – Schedule LTL Pickup

a) Upon Accumulating 200 kits (1 Over-pack/Pallet) or **30 days since last shipment**:

- Follow request instructions on pick-up
- Have the following Information Available
 - Dealer Number
 - Quantity of Over-pack Pallets(200) or individual boxes
 - Quantity of Passenger Inflator Kits on each Over-Pack Pallet
 - Email Address where shipping Documentation can be received

7. Shipping Instructions – Ship

- Give 1 Copy of BOL and ERG to driver
- Retain 1 Copy of BOL for Dealership records and archive for 2 Years

8. Requesting a New Box / Shipping Labels

If a new box or replacement shipping labels are needed, please email to request replacement materials.

E-Mail: MLGTakataRestrains_International@menlowworldwide.com

To help expedite your request, provide the following information:

- Serial number on the original box
- What Type of shipping material needed
 - Replacement Box
 - Two Part Return Label - * if included
 - This picture may appear different on the box
- Dealer Shipping Information
 - Contact name
 - Dealer Address
 - Phone Number



CANADIAN DEALER DO NOT CONTACT XPO

Do not ship with label inside the box
Label on the box will vary as per country of origin
Please file all tracking documents
Contact your Campaign Specialist