

KZ-RV Solera Awning Smart Arm Controller Recall: #18V-242/ TC (Transport Canada) #2018286

Parts Required

- 733832 - Smart Arm Controller Kit
(kit includes: 717666 - Smart Arm Controller and 733833 - Recall Repair Document)

NOTE: Please log onto the LCI store at <http://store.lci1.com/> to place your order for the kit. No pre-authorization is required by LCI or KZ for an order to be placed and this repair to occur.

Safety

⚠ WARNING

Moving parts can pinch, crush or cut. Holding the controller from both sides can cause serious personal injury if the awning is retracted completely. Press the buttons from the touchpad side only.

Instructions

Removal

- Press and hold the unlock button (Fig. 1A) until the green light illuminates.
- Press and hold the extend arrow button (Fig. 1B) until the awning is fully extended.
- Remove the snap clip, wire cover and connector small wire cover (Fig. 1) from the drive side awning arm assembly.
- If equipped with an infrared (IR) sensor (Fig. 4), disconnect by unplugging it from the bottom of the smart arm controller (Fig. 3) and retain for reinstallation.
- Remove the smart arm controller from the drive side mount arm.
- Detach the connector harness (Fig. 2) from the smart arm controller.

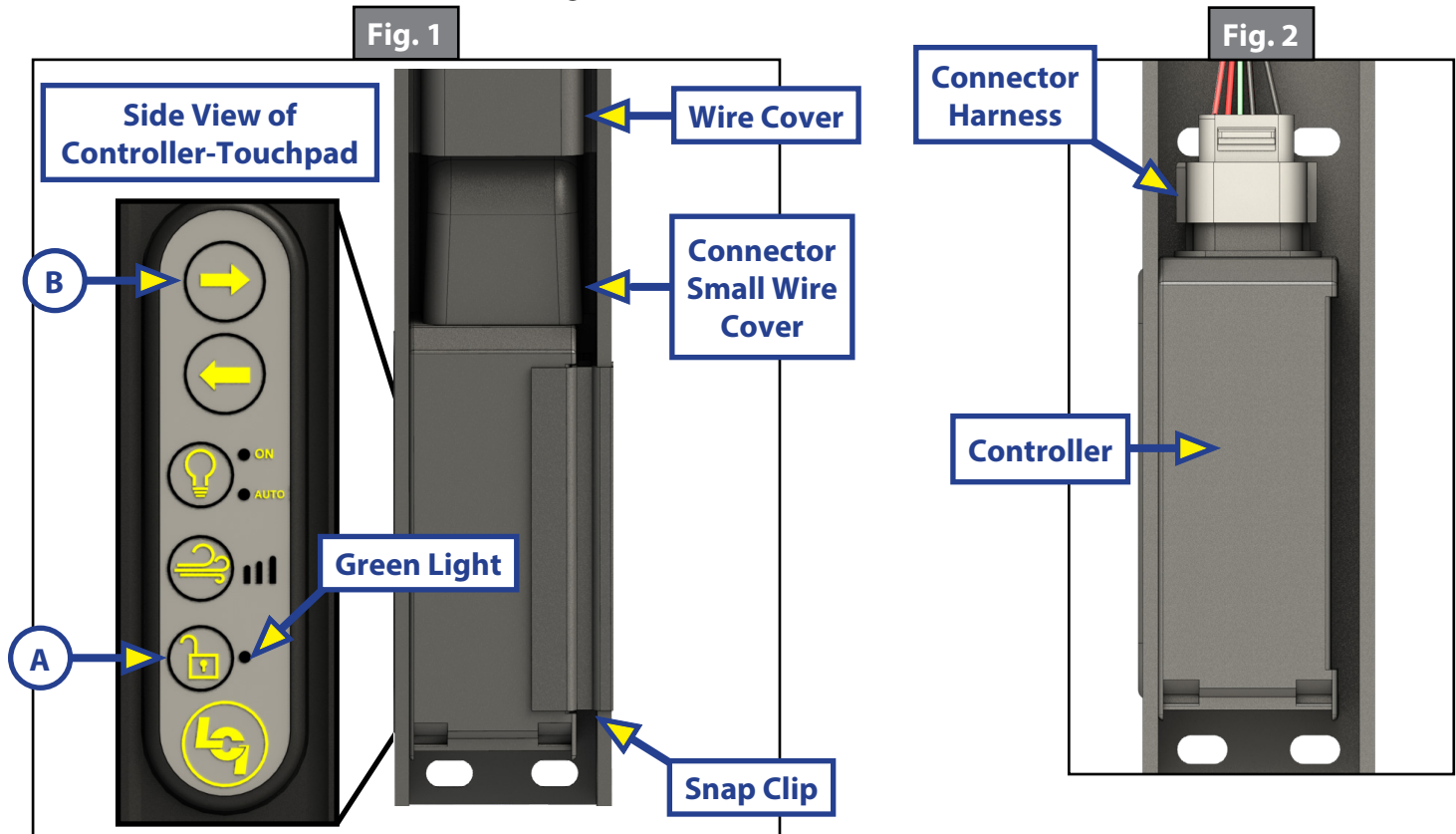

Installation

NOTE: Steps 1 and 2 pertain to connecting the IR sensor to the smart arm controller. If not equipped with the IR sensor, skip to step 3.

1. Remove the protective tape (Fig. 3) covering the connection pins at the bottom of the smart arm controller.
2. Align the IR sensor (Fig. 4) to the bottom of the smart arm controller with the white sensor dome facing outward. Line up notches on the front of the controller (Fig. 3A) with the tabs of the IR sensor (Fig. 4A), then push the IR sensor up and back to lock the sensor into place.

NOTE: The tab on the back of the IR sensor (Fig. 4B) will snap onto a tab at the bottom of the smart arm controller.

3. Plug the connector harness into the smart arm controller (Fig. 2).

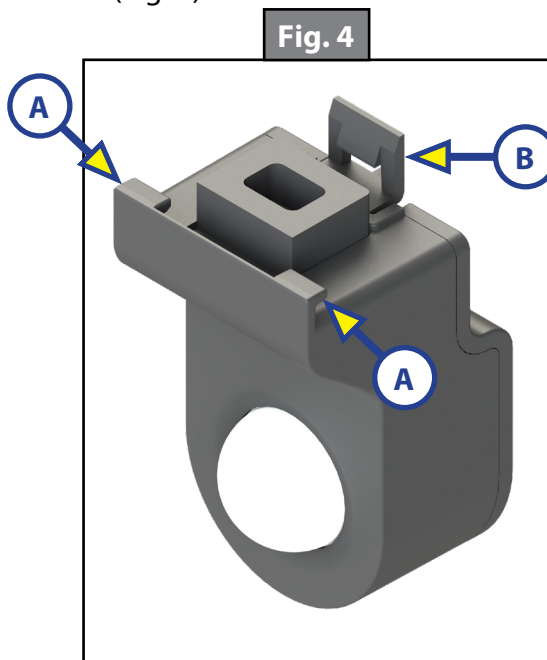

4. Fit the smart arm controller back into place so the touchpad face of the controller fits into the hole in the drive side mount arm, then push the snap clip into place (Fig. 1).
5. Reinstall the connector small wire cover and wire cover (Fig. 1), in that order.

To File Claim For Warranty Reimbursement

Please submit your completed work order with full unit information (including 17-digit VIN, Brand/Model and Date of Mfr) directly to LCI via email. Your submission must include a clear photo of the destroyed controller with the controller serial number (Fig. 5). Please send with repair documents via email to dealerclaims@lci1.com.

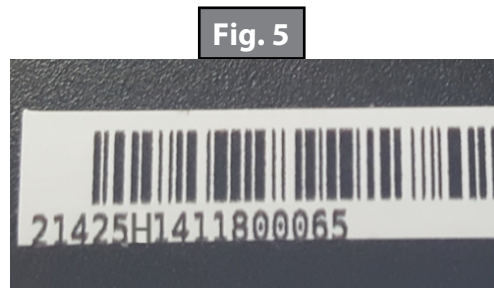

NOTE: Serial number is found on the side of the controller opposite the touchpad.