

IMPORTANT UPDATE

TECHNICAL INSTRUCTIONS

FOR

SAFETY RECALL J0K

VACUUM PUMP

**CERTAIN 2018 Toyota Highlander
2017 Toyota Sienna**

- **May 7th 2018: Update to thread adhesive and application**

The repair quality of covered vehicles is extremely important to Toyota. All dealership technicians performing this recall are required to successfully complete the most current version of the E-Learning course "Safety Recall and Service Campaign Essentials". To ensure that all vehicles have the repair performed correctly; technicians performing this recall repair are required to currently hold at least one of the following certification levels:

- Certified Technician (Engine)
- Expert Technician (Engine)
- Master Technician
- Master Diagnostic Technician

It is the dealership's responsibility to select technicians with the above certification level or greater to perform this recall repair. Carefully review your resources, the technician skill level, and ability before assigning technicians to this repair. It is important to consider technician days off and vacation schedules to ensure there are properly trained technicians available to perform this repair at all times.

I. OPERATION FLOW CHART

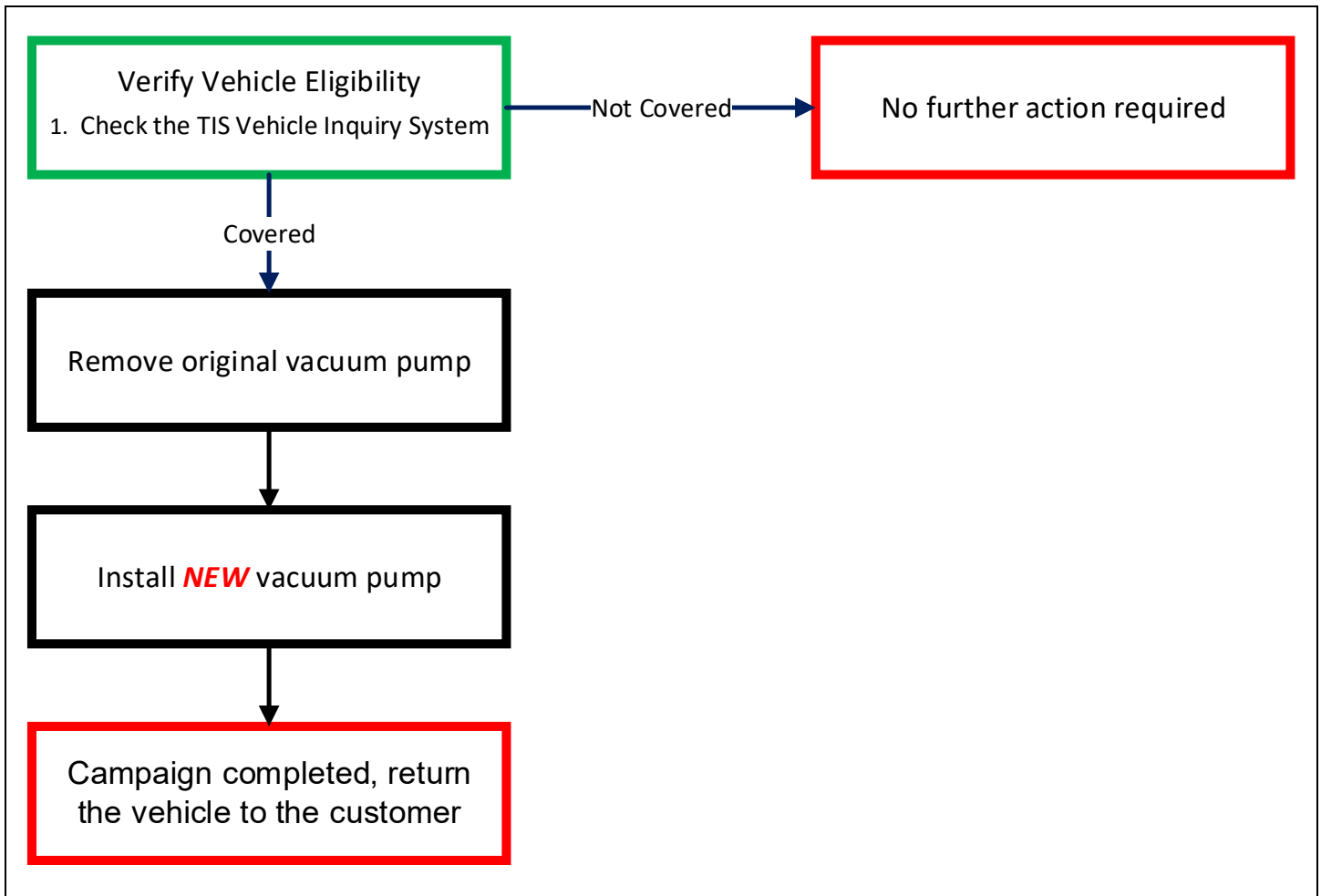

II. IDENTIFICATION OF AFFECTED VEHICLES

- Check the TIS Vehicle Inquiry System to confirm the VIN is involved in this Safety Recall, and that it has not already been completed prior to dealer shipment or by another dealer.
- TMS warranty will not reimburse dealers for repairs completed on vehicles that are not affected or were completed by another dealer.

III. PREPARATION

A. PARTS

Part Number	Part Description	Quantity
29300-0P011	Vacuum Pump	1
22271-0P020	Throttle Body Gasket	1
90105-A0127	Bolt, Flange	3

B. TOOLS & EQUIPMENT

- Techstream
- Standard Hand Tools
- Torque Wrench

C. MATERIALS

- Toyota Genuine Adhesive 1324, Three Bond 1324 or equivalent

IV. BACKGROUND

The involved vehicles are equipped with a vacuum pump assembly, which provides braking assist. A component in the vacuum pump assembly may have been manufactured incorrectly. This condition could lead to the illumination of a warning light, a warning message, an audible tone, and result in the sudden loss of braking assist. A sudden loss of braking assist while driving could increase the risk of a crash.

VACUUM PUMP ASSEMBLY

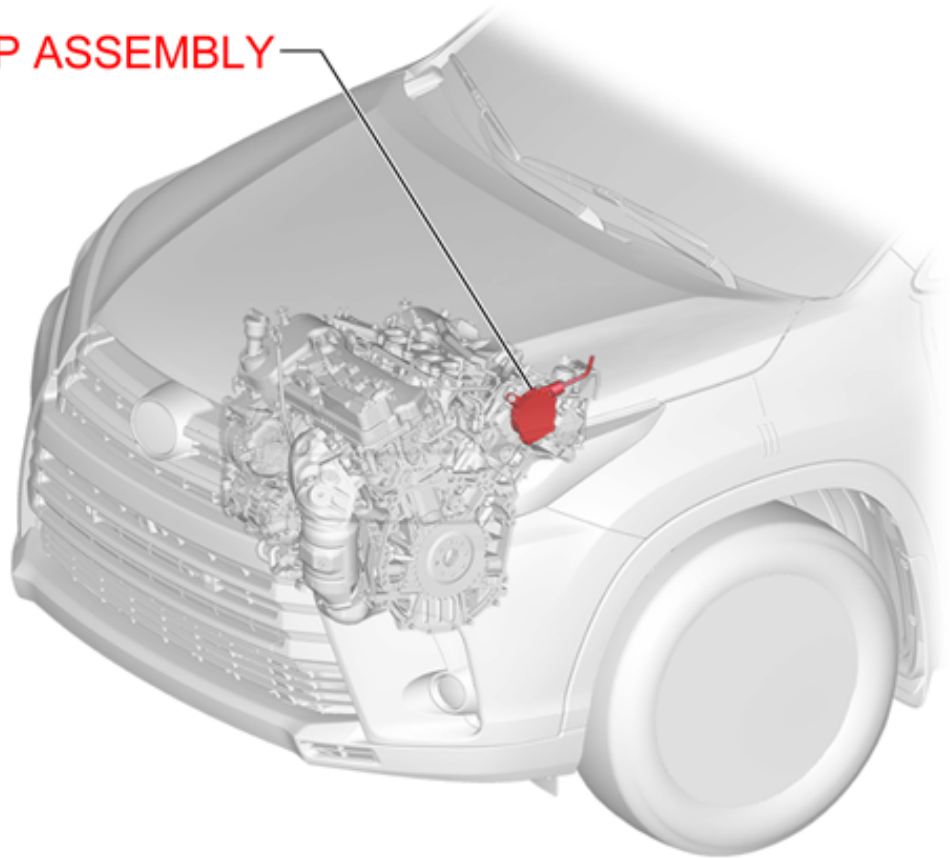

V. COMPONENTS

Highlander is shown as a representative example:

Only for Highlander:

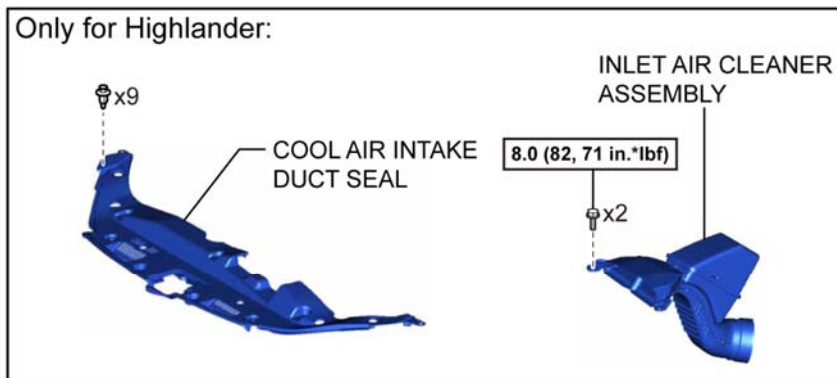

Only for Sienna:

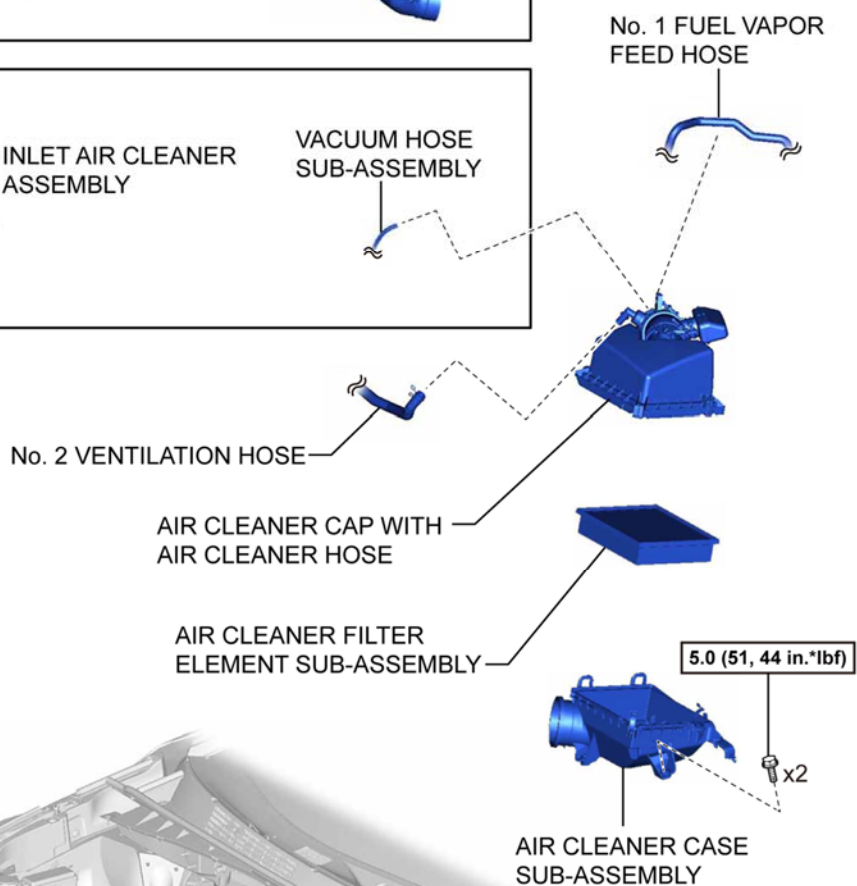
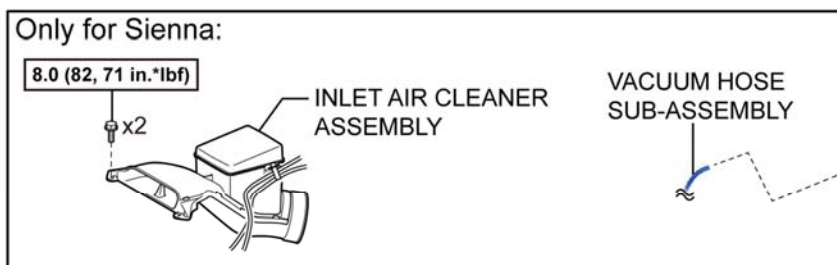

N*m (kgf*cm, ft.*lbf) : Specified torque

S01011dS

Highlander is shown as a representative example:

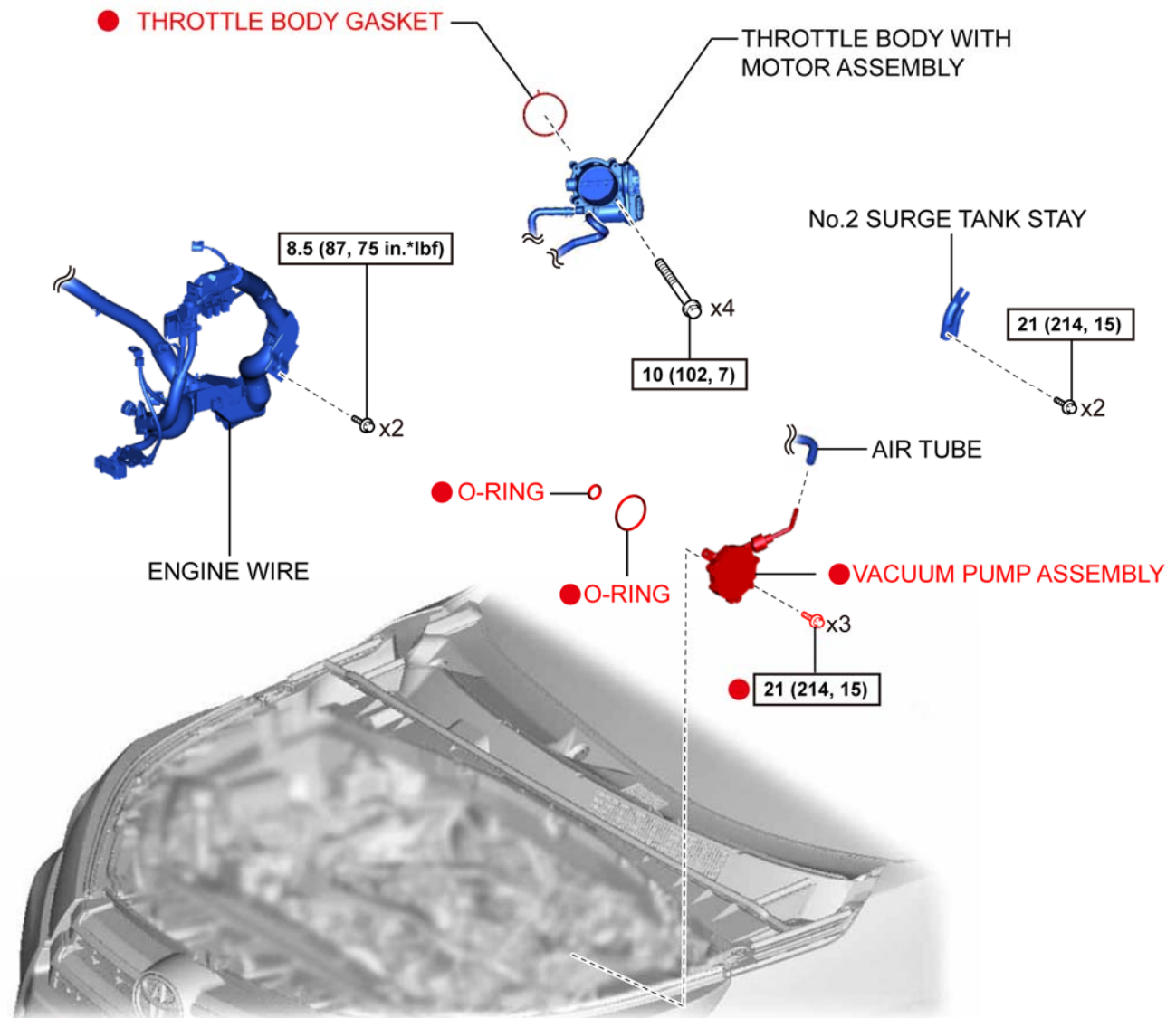

● : Component to be replaced

N*m (kgf*cm, ft.*lbf) : Specified torque

S01012dS

VI. DISASSEMBLY

1. DISCONNECT CABLE FROM NEGATIVE BATTERY TERMINAL

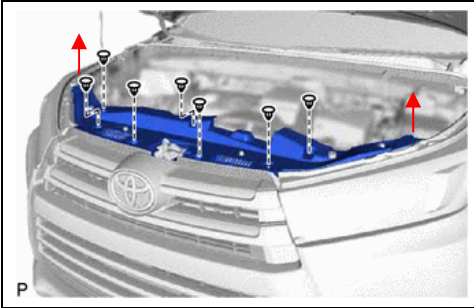

2. REMOVE THE COOL AIR INTAKE DUCT SEAL (Highlander Only)

- Remove the 9 clips and the cool air intake duct seal.

Note: It is not necessary to remove the radiator side shields.

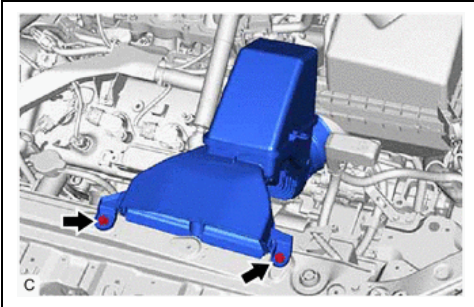

3. REMOVE THE AIR CLEANER INLET (Highlander Only)

- Remove the 2 bolts and the air cleaner inlet.

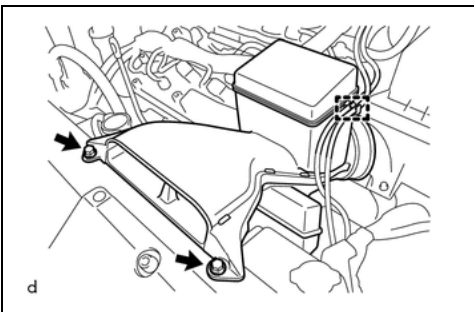

4. REMOVE THE AIR CLEANER INLET (Sienna Only)

- Disengage the clamp.
- Remove the 2 bolts and the air cleaner inlet.

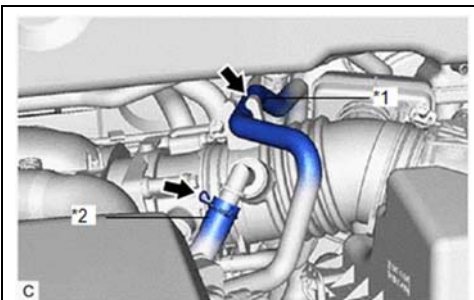

5. REMOVE AIR CLEANER CAP AND HOSE

- Disconnect the MAF sensor connector.
- Disengage the MAF wire harness clamp.
- Disengage the No. 1 fuel vapor feed hose from the air cleaner hose.
- Slide the clip and disconnect the No. 2 ventilation hose from the air cleaner hose.

*1 No. 1 Fuel Vapor Feed Hose

*2 No. 2 Ventilation Hose

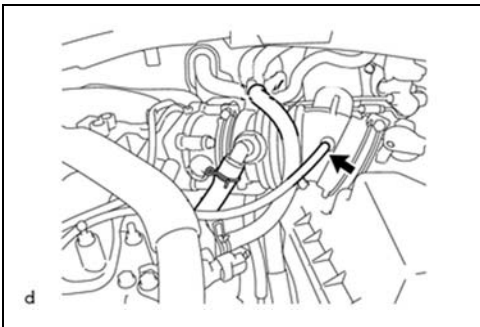

e. Disengage the vacuum hose from the air cleaner hose.
(Sienna Only)

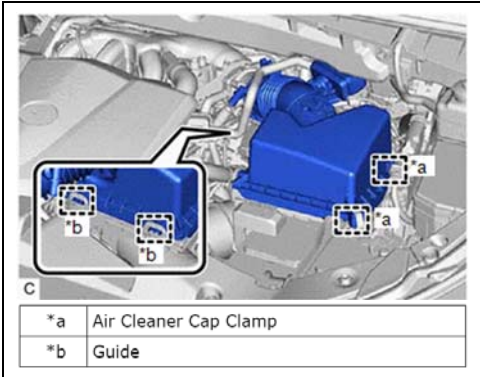

- f. Disengage the 2 air cleaner clamps.
- g. Disengage the 2 guides to separate the air cleaner cap from the air cleaner case.
- h. Loosen the hose clamp and remove the air cleaner cap with the hose from the throttle body.
- i. Remove the air cleaner filter element.

6. REMOVE AIR CLEANER CASE

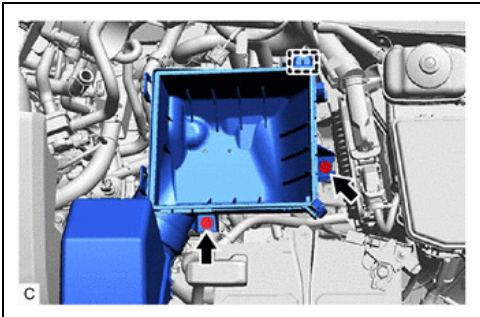

- a. Remove the 2 bolts.
- b. Disengage the guide (Highlander only) from the air cleaner support bracket to remove the air cleaner case.

7. REMOVE THROTTLE BODY

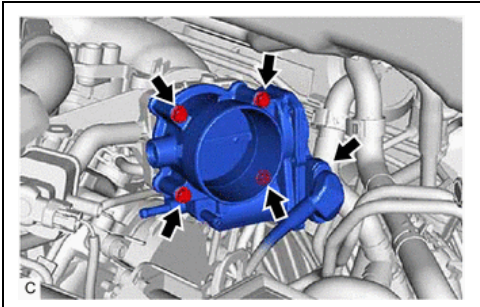

- a. Disconnect the throttle body connector.
- b. Remove the 4 bolts and separate the throttle body from the intake.

c. Move the throttle body to the side as shown in the picture.

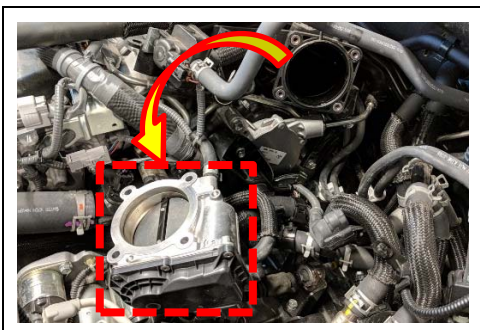

Note: Leave coolant hoses attached to throttle body

VII. REPLACE VACUUM PUMP

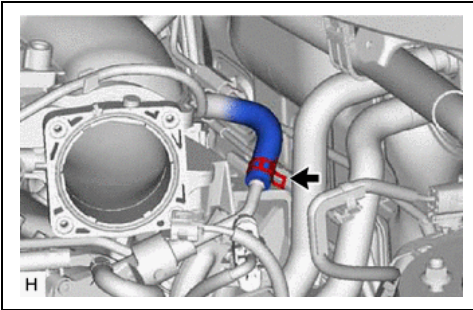

- 1. DISCONNECT VACUUM PUMP AIR TUBE**
 - a. Slide the clamp and disconnect the air tube from the vacuum pump.

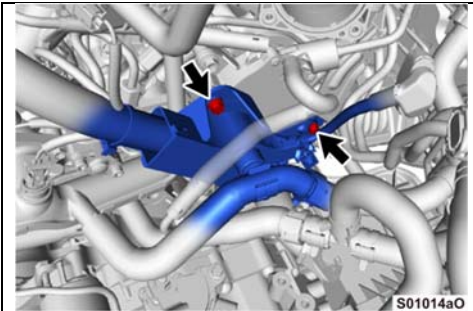

- 2. SEPARATE ENGINE HARNESS FROM ENGINE**
 - a. Remove the 2 bolts as shown in the picture.

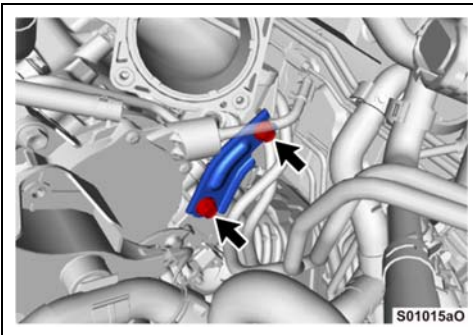

- 3. REMOVE No. 2 SURGE TANK STAY**
 - a. Remove the 2 bolts.



- 4. REMOVE THE VACUUM PUMP**
 - a. Pull back on wiring harness to gain access to the 3 vacuum pump bolts as shown in the picture.

Note: Place shop towel underneath pump to catch any oil during pump removal.

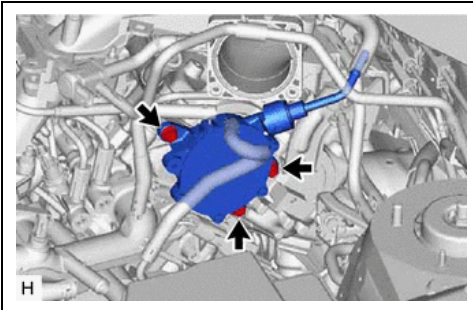

- b. Remove the 3 bolts and vacuum pump from the engine.

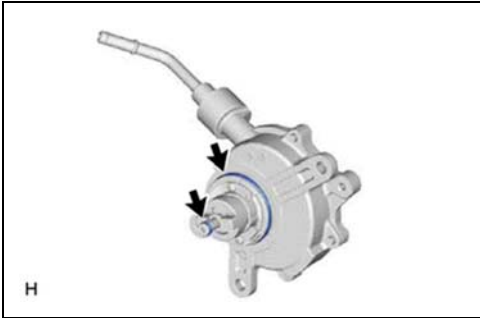

5. **INSTALL NEW VACUUM PUMP**
 a. Apply engine oil to the 2 **NEW** O-rings

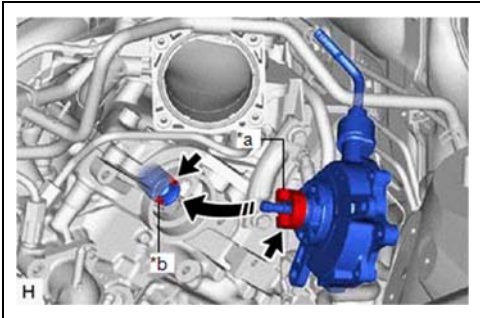

- b. Ensure the tabs on the **NEW** vacuum pump engage properly with the grooves on the camshaft.

*a	Tab
*b	Groove

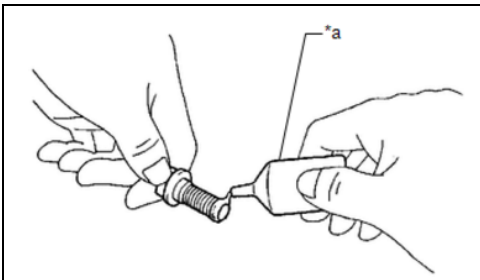

- c. Apply sealant to all 3 **NEW** pump housing bolts.
Standard: Toyota Genuine Adhesive 1324, Three Bond 1324 or equivalent.

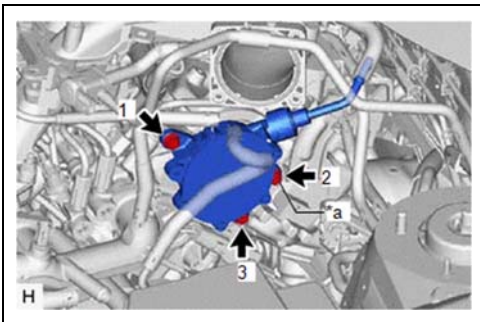

- d. Install the 3 **NEW** bolts with adhesive applied.
Torque: 15 lbf.ft {21 N·m, 214 kgf·cm}

VIII. REASSEMBLY

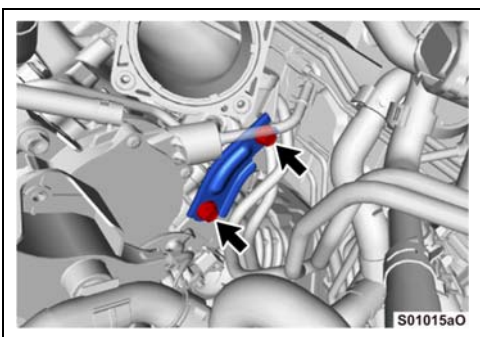

1. **INSTALL No. 2 SURGE TANK STAY**
 a. Install the side stay with the 2 bolts.
Torque: 15 lbf.ft {21 N·m, 214 kgf·cm}

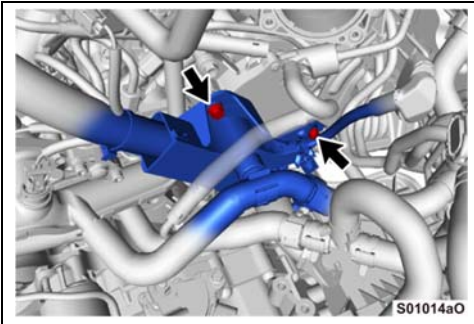

2. INSTALL ENGINE HARNESS

- a. Install the engine harness with the 2 bolts.

Torque: 74 lbf.in {8.4 N·m, 85 kgf·cm}

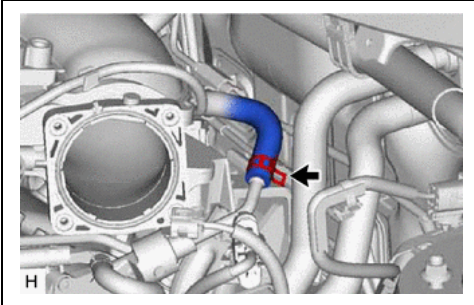

3. INSTALL VACUUM PUMP AIR TUBE

- a. Connect the air tube to the vacuum pump and slide the clamp on to secure it.

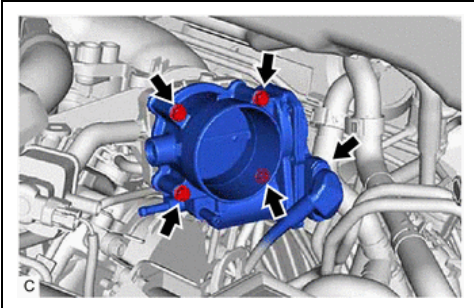

4. INSTALL THROTTLE BODY

- a. Install the throttle body with the 4 bolts.

Torque: 84 lbf.in {10 N·m, 102 kgf·cm}

- b. Connect the throttle body connector.

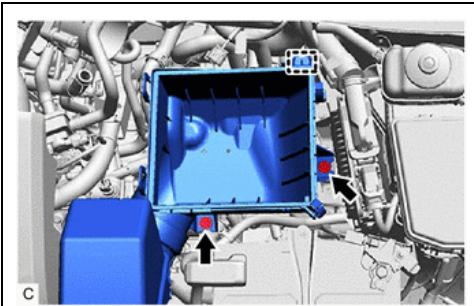

5. INSTALL AIR CLEANER CASE

- a. Engage the guide on the air cleaner support bracket (Highlander only).
- b. Install the air cleaner case with the 2 bolts.

Torque: 44 lbf.in {5 N·m, 51 kgf·cm}

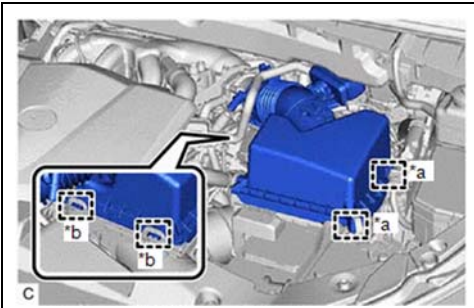

6. INSTALL AIR CLEANER CAP AND HOSE

- a. Install the air filter element
- b. Install the hose to the throttle body and tighten the hose clamp.
- c. Engage the 2 air cleaner guides.
- d. Engage the 2 air cleaner cap clamps.
- e. Engage the MAF wire harness clamp.
- f. Connect the MAF sensor connector.

*a	Air Cleaner Cap Clamp
*b	Guide

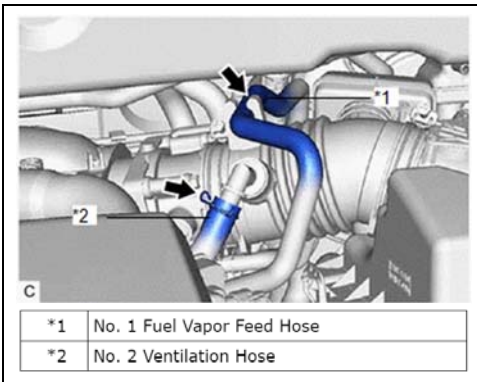

- g. Engage the No. 1 fuel vapor feed hose.
- h. Connect the No. 2 ventilation hose and slide the clamp to secure it.

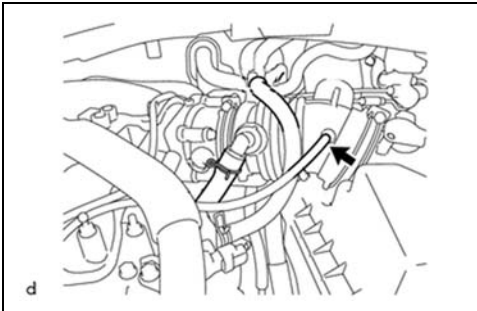

- i. Engage the vacuum hose. (Sienna Only)

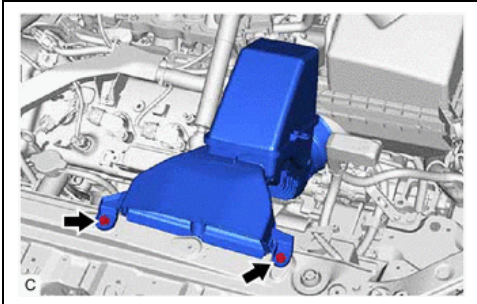

7. INSTALL AIR CLEANER INLET (Highlander Only)

- a. Install the air cleaner inlet with the 2 bolts.

Torque: 71 lbf.in {8.0 N·m, 82 kgf·cm}

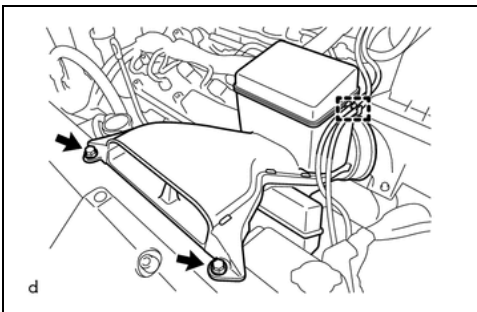

8. INSTALL THE AIR CLEANER INLET (Sienna Only)

- a. Install the air cleaner inlet with the 2 bolts.

Torque: 71 lbf.in {8.0 N·m, 82 kgf·cm}

- b. Engage the clamp.

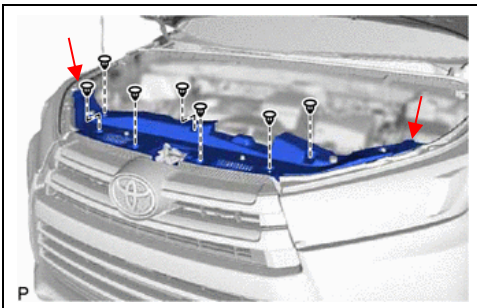

9. INSTALL THE COOL AIR INTAKE DUCT SEAL (Highlander Only)

- a. Install the cool air intake duct seal with the 9 clips.

10. CONNECT CABLE TO NEGATIVE BATTERY TERMINAL

Specified Torque: 48 lbf.in {5.4 N·m, 55 kgf·cm}

◀ VERIFY REPAIR QUALITY ▶

1. Confirm proper operation of the power assist brakes
2. Confirm there are no oil leaks
3. Confirm there are no warning lights illuminated

If you have any questions regarding this update, please contact your regional representative.

10. APPENDIX

A. PARTS DISPOSAL

As required by Federal Regulations, please make sure all recalled parts (original parts) removed from the vehicle are disposed of in a manner in which they will not be reused, **unless requested for parts recovery return.**

B. CAMPAIGN DESIGNATION DECORDER

