 <b>HYUNDAI</b> <b>Technical Service Bulletin</b>	<b>GROUP</b> <b>RECALL</b>	<b>NUMBER</b> <b>24-01-079H</b>
	<b>DATE</b> <b>SEPTEMBER 2024</b>	<b>MODEL(S)</b> <b>SONATA (YF)</b> <b>SONATA HYBRID (YF HEV)</b>
<b>SUBJECT:</b> AIRBAG CONTROL UNIT (RECALL 174)		

This TSB supersedes 18-01-030 to update the parts and warranty information on page 2 and apply steps 2-4 for ground extension wiring installation to the Sonata on pages 12-13.

**\* IMPORTANT**

Vehicle repairs related to safety recalls are critically important and must be performed properly in accordance with TSB procedures. Review this bulletin in its entirety prior to beginning any repair work.

As required by federal law, dealers must not deliver new vehicles for sale or for lease to customers until all open recalls have been performed. Dealers must also perform all open recalls on used vehicles, demo, and rental vehicles prior to placing them into customer use and whenever an affected vehicle is in the shop for any maintenance or repair.

Access the “Vehicle Information” screen via WebDCS to identify open recalls.

**Description:** Sonata (YF) and Sonata Hybrid (YF HEV) vehicles are equipped with an airbag control unit (or module) which detects collisions and commands deployment of the airbags and seat belt pretensioners as necessary. If the control unit’s circuitry is damaged, the airbags and seat belt pretensioners may not deploy in some collisions where deployment is warranted, increasing the risk of injury.

This bulletin describes the procedure to install an airbag control unit wiring filter kit to prevent the damage to the control unit’s circuitry.

**Applicable Vehicles (Certain):**

- 2011–13MY Sonata (YF) produced from 12/11/2009 – 08/31/2012
- 2011–12MY Sonata Hybrid (YF HEV) produced from 12/07/2010 – 09/04/2012

**Required Equipment/Supplies:**

Tool Name	Figure
Plastic Trim Tool	

**Parts Information:**

Model	Part Name	Part Number	Figure	Remarks			
				#	Parts	Qty	
Sonata Hybrid (YF HEV)	Wiring Kit	91700-4R000QQH		1	BAND STRAP	4	
				2	PAD	200x50mm	2
				3	PAD	100x60mm	1
				4	PAD	50x35mm	2
				5	BAND CABLE	1	
				6	DIODE MODULE	1	
				7	GROUND EXTENSION WIRING	1	

**NOTE:** Please order this part first for Sonata Hybrid before ordering 91700-4R100QQH. They are equivalent parts, just from a different vendor.

Model	Part Name	Part Number	Figure	Remarks				
				#	Parts	Part Number	Qty	
Sonata (YF)	Wiring Kit	91700-4R100QQH		1	B/Strap	200x3.6 B	N/A	4
				2	Pad	200x50 mm		2
100x60 mm						1		
50x35 mm						2		
3				B/Cable	17998-15207	1		
4	Diode Module	95950-2T000	1					
Sonata Hybrid (YF HEV)			5	Extension Wiring	91700-4R100	1		

**Warranty Information:**

Model	Op. Code	Operation	Op. Time	Casual Part	Nature Code	Cause Code
Sonata (YF) Sonata Hybrid (YF HEV)	81C049R0	ACU Main Wiring Harness Installation (Used 91700-3S000QQH or 91700-4R000QQH)	0.6 M/H	95910-3Q110	I11	ZZ3
Sonata Hybrid (YF HEV)	81C049R1	ACU Main Wiring Harness Installation (Used 91700-4R100QQH)				

**NOTE 1:** Submit claim on Claim Entry Screen as “Campaign” type.

**NOTE 2:** If a part is found in need of replacement while performing this recall and the affected part is still under warranty, submit a separate claim using the same repair order. If the affected part is out of warranty, submit a Prior Approval request for goodwill consideration prior to performing the work.

**NOTE 3:** This TSB includes Repair validation photos. Op times include VIN, Mileage, and Repair validation photo(s) as outlined in the Digital Documentation Policy.

**NOTE 4:** The incident parts are subject to callback through the normal Warranty Technical Center (WTC) parts return process. **Claim is subject to debit if the part is not returned.**

**Service Procedure:**

## Wiring Preparation

1. Place the diode module (A) towards the main wiring connector (B).

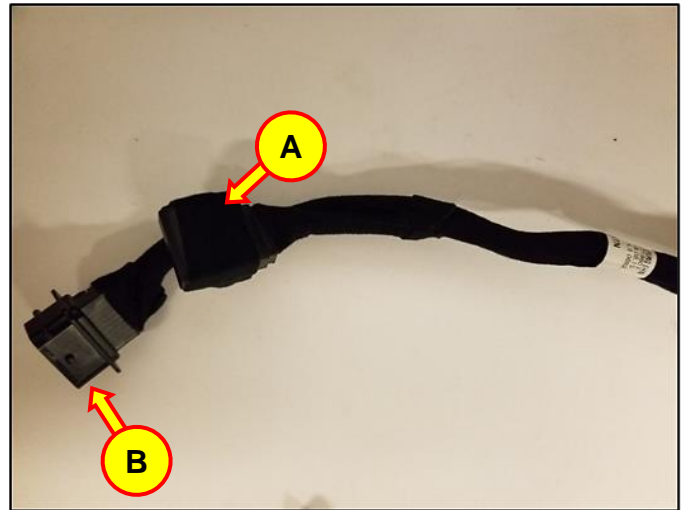

2. Use the 200x50mm pad (C) from the wiring kit to wrap the diode module and wiring connector together.

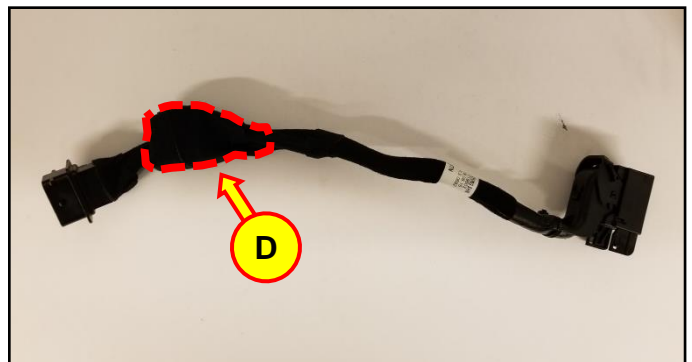

ACU Wiring Harness Installation

1. Record the customer's radio presets.
2. Apply the parking brake.
3. Place the ignition key to the **OFF** position.
4. Refer to the shop manual to remove the floor console (E)
  - **Body (Interior and Exterior) > Interior > Console > Repair procedures**

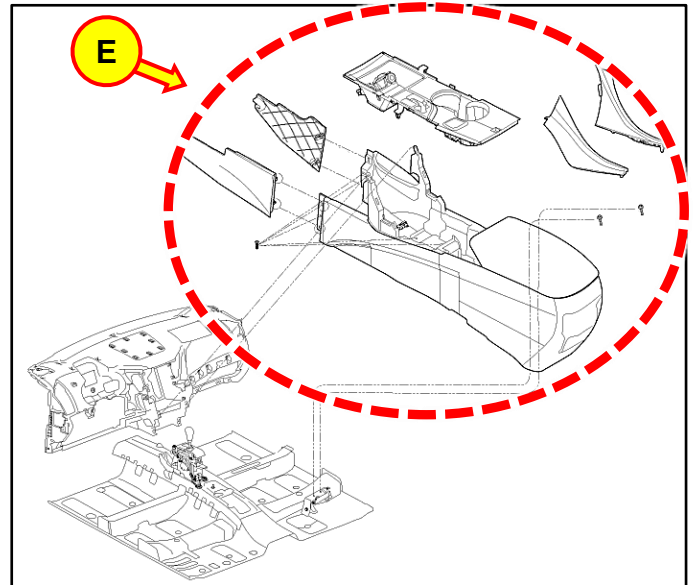

5. Open the hood (YF) or trunk (YF HEV).  
  
Disconnect the negative (-) terminal (F) from the battery.

**Tightening Torque:**

lb-ft	1.7
lb-in	21
N.m	2.4



**CAUTION**

Wait for **3+ minutes** before proceeding to ensure the battery is discharged.

To prevent an accidental airbag deployment that can potentially cause injury, ensure the negative (-) terminal is removed from the battery.

6. Remove the heater duct (G).

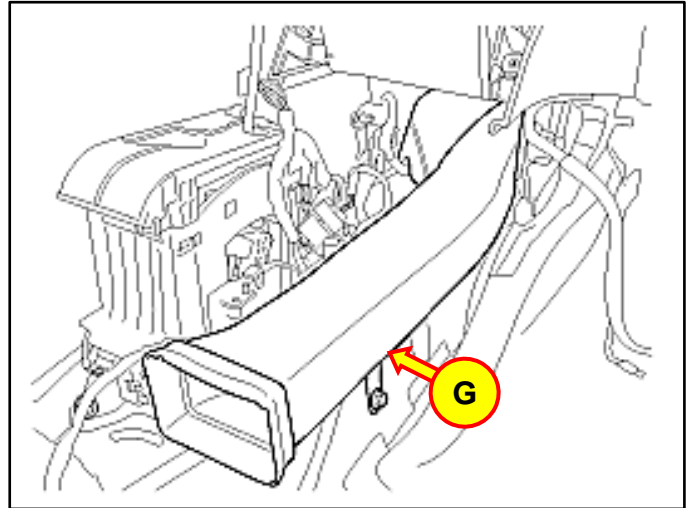

7. Gently remove the mounting clip (H) from the LH wiring connector with a clip/trim tool.

**i** Information

The mounting clip will be reused in step 9.

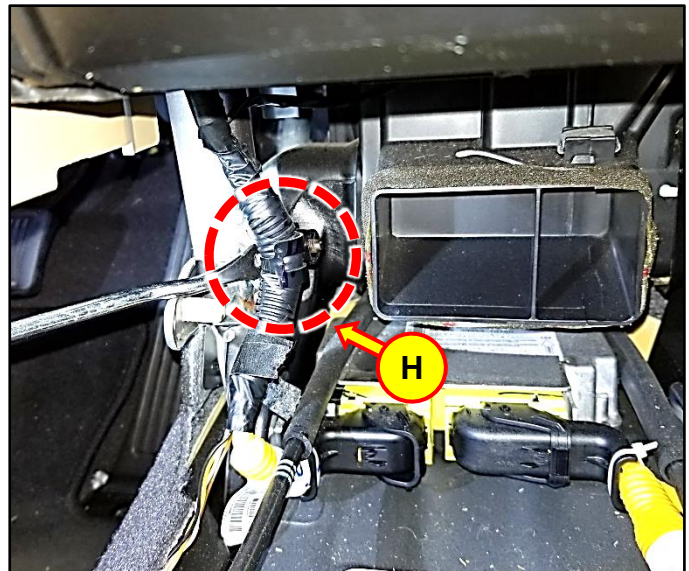

8. Slide the tab (I) inward and gently remove the mounting clip from the LH wiring connector.

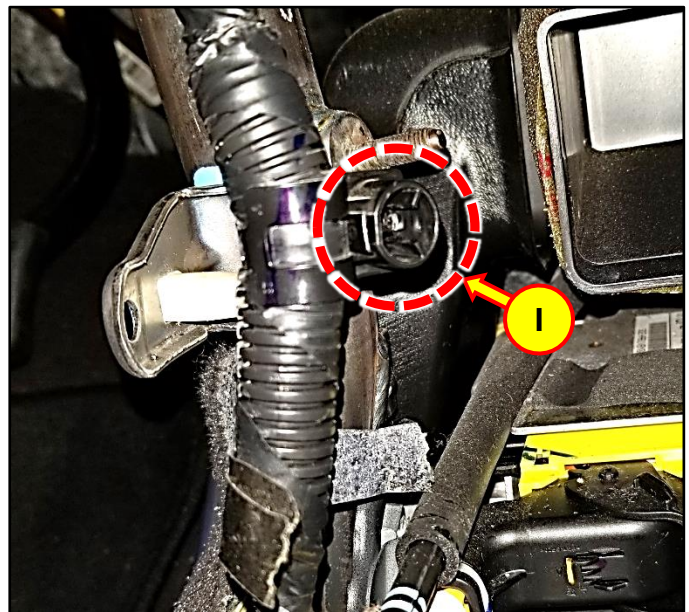

9. Orient the mounting clip to face the opposite side (J) and reinstall the mounting clip.

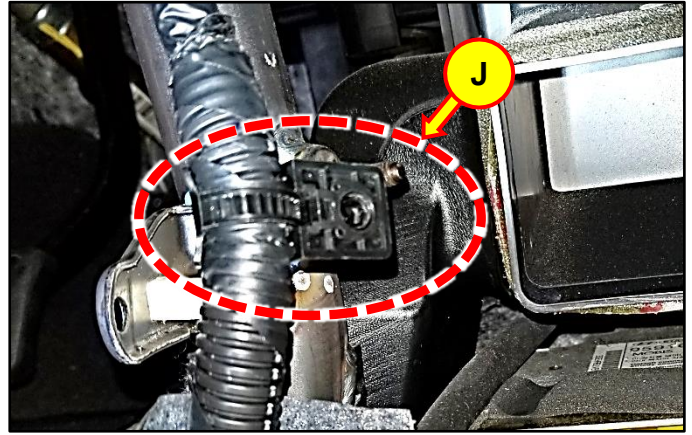

10. Install the mounting clip to the main wiring mounting terminal (K).

Ensure the main wiring is positioned behind the mounting terminal.

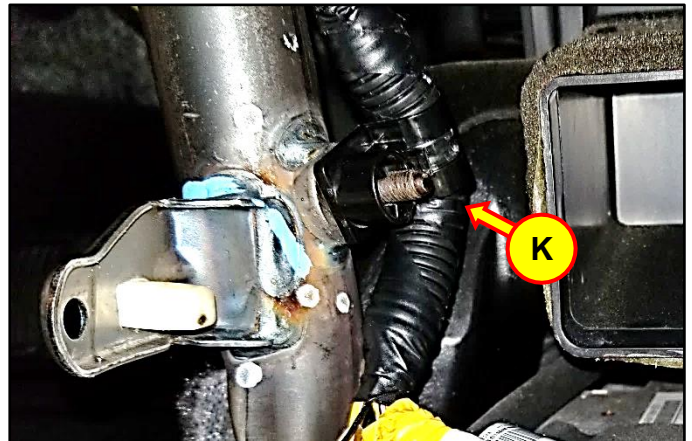

11. Disconnect the LH wiring connector (L) from the main wiring.

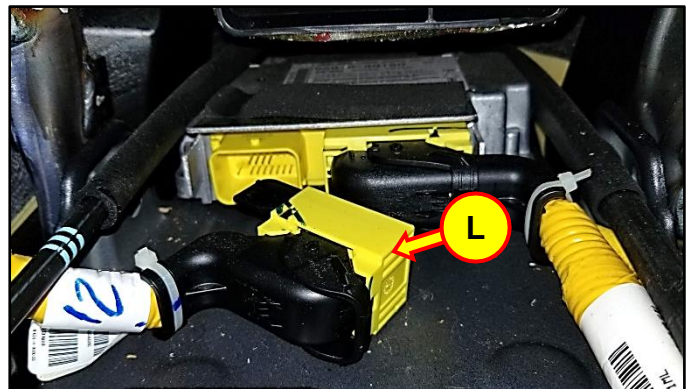

12. Gently move the LH connector above the cable assembly-ATM/MTM (M).

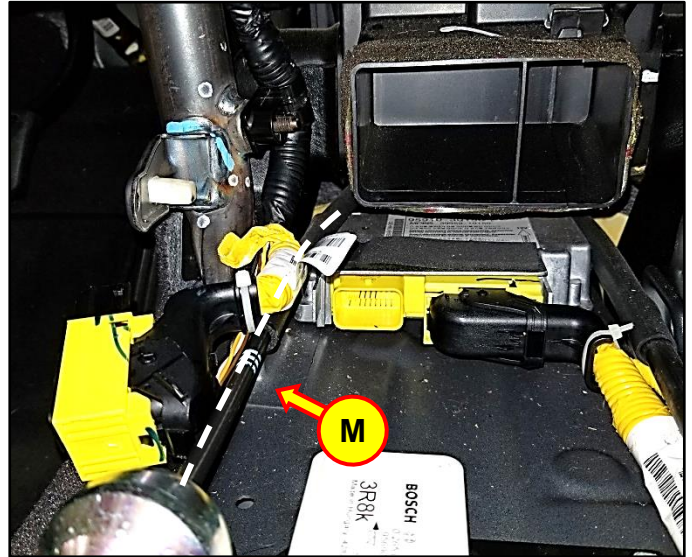

13. Connect and lock the Airbag Control Unit (ACU) connector (N) of the wiring filter kit to the ACU.

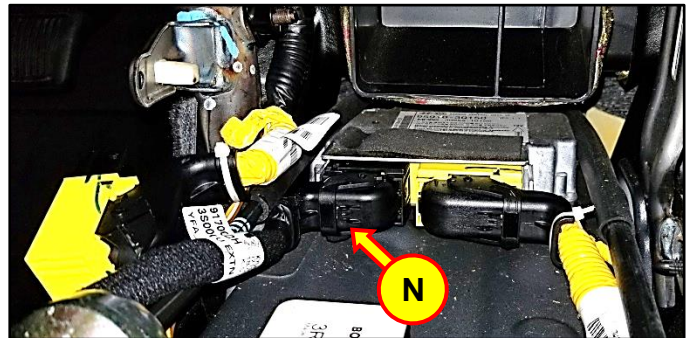

14. Install the main wiring connector (O) of the wiring filter kit to the LH connector of the main wiring (P).



15. Wrap the main wiring connector (Q) using the 200X50 mm pad (R).

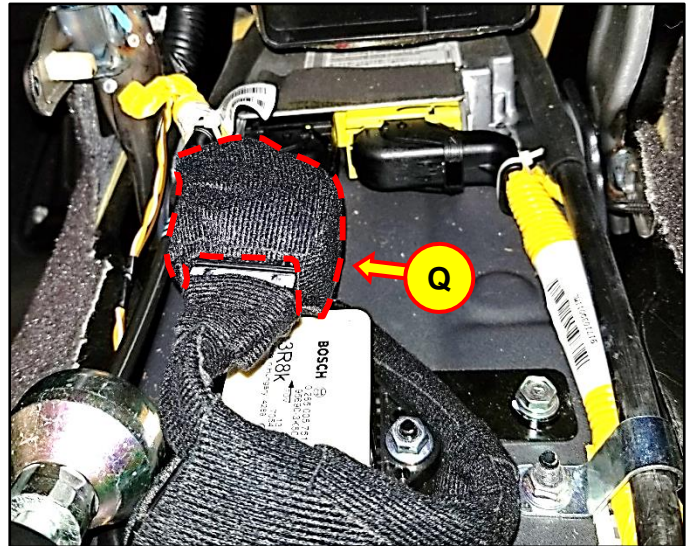

16. Place the 100X60 mm pad (S) on the main wiring connector along the wiring (T).



17. Gently move the wiring filter kit connection (without the ground extension wiring (U) intended for Sonata Hybrid Only) to store left (V) of the heater duct opening (W).

**i** Information

The wiring filter kit connection must be stowed away from the heater duct opening to re-install the heater duct without any interference.

**Ground Extension Wiring Installation** for the Sonata Hybrid can be found on **page 12**.



- 18. Install the band cable (X) from the wiring filter kit to the mounting hole (Y) and wrap around the wiring to keep it in place.

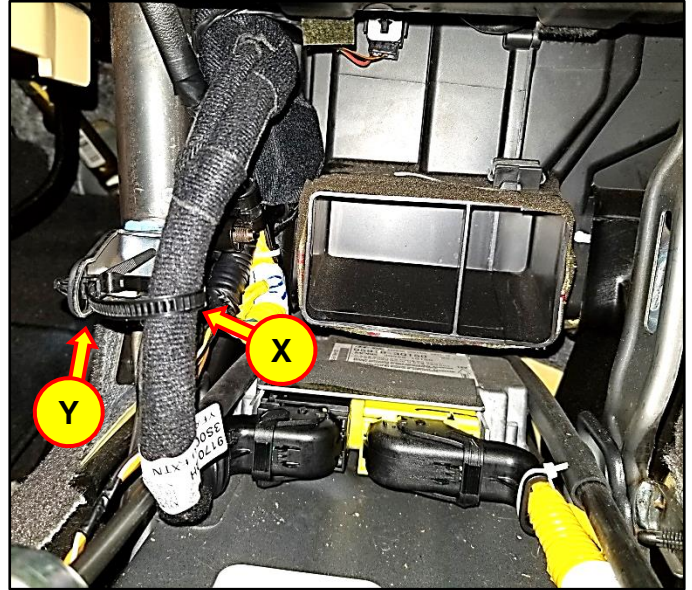

- 19. Tighten the band cable and trim the excess band cable (Z).

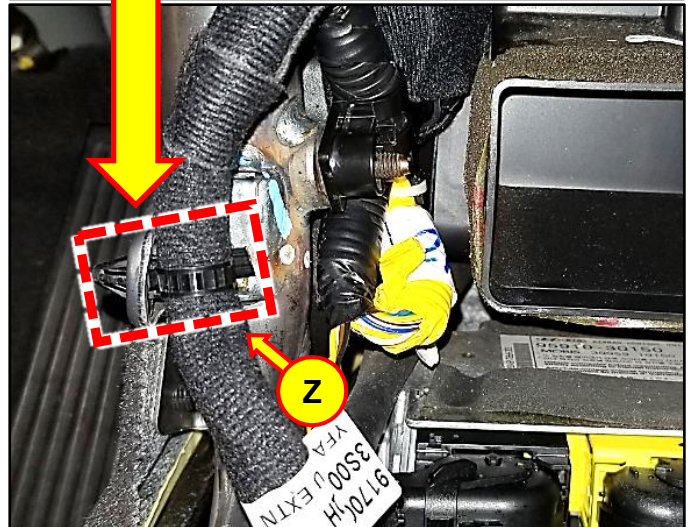
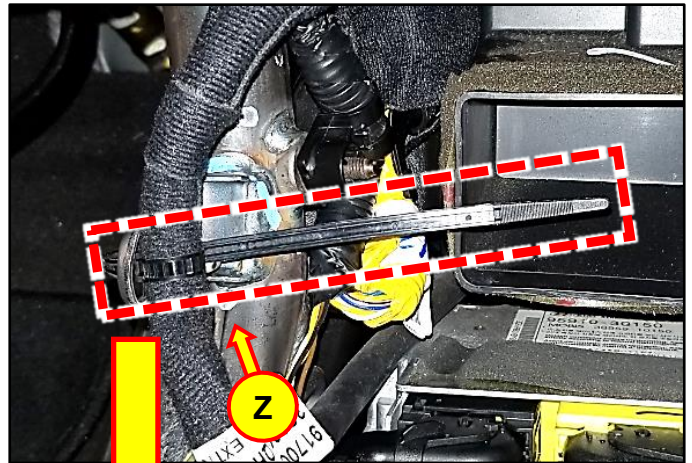

20. Use two 50x35mm pads (AA) to wrap the band cable and mounting hole to prevent wiring interference.

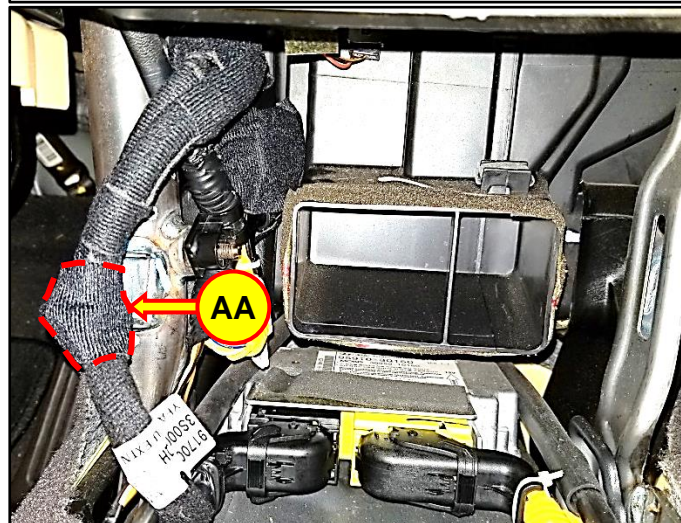
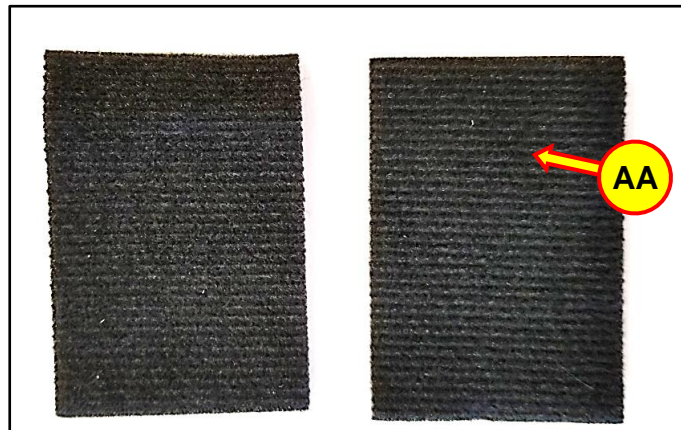

21. Gently tie the band strap(s) (AB) from the wiring filter kit around the wirings and the metal brace (AC).



Trim the excess band strap(s).

**i Information**

Use an appropriate amount of band straps to keep wiring in place.

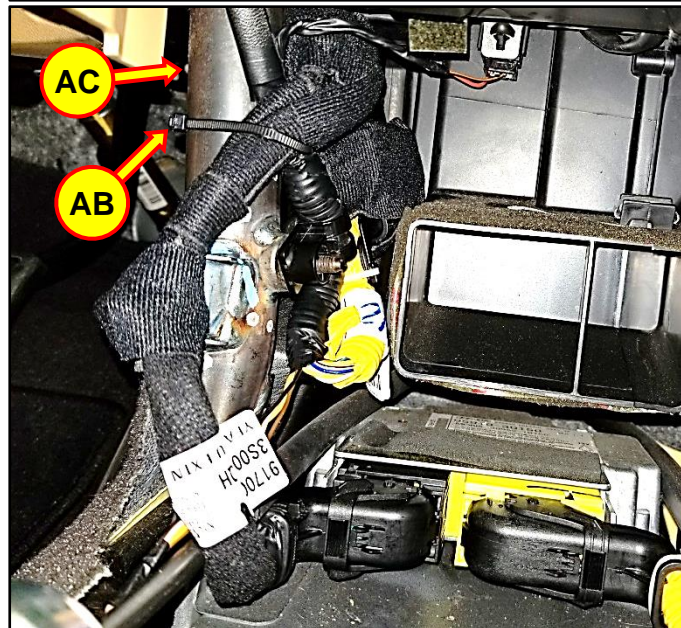

**Ground Extension Wiring Installation**

1. Perform steps 2-8 for both models.

***i* Information**

The ground extension wiring is captured in red dotted light in picture to the right.



2. Disconnect the ACU RH connector (A).

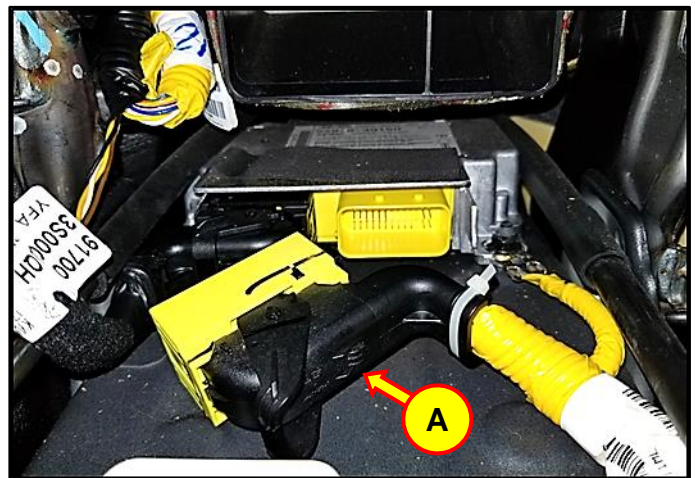

3. Remove the mounting bolt (B) located next to the RH connector of ACU.

Install the ground extension wiring (C) with the mounting bolt.

**Tightening Torque:**

lb-ft	8.7
lb-in	103.8
N.m	11.8

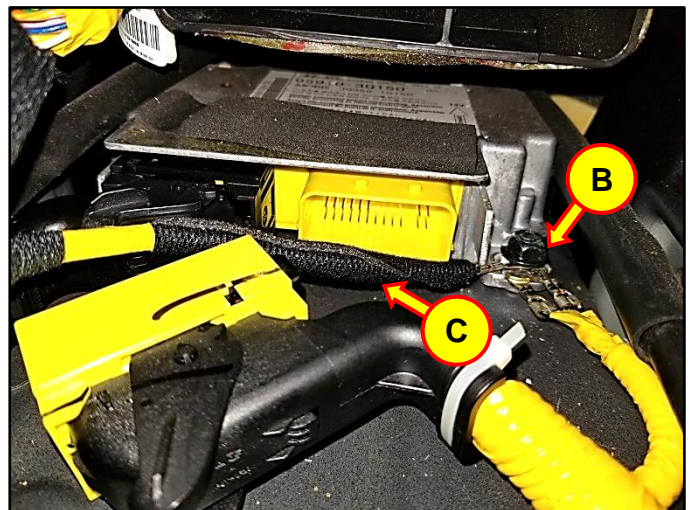

4. Connect the ACU RH connector (D).



5. Reinstall the heater duct.
6. Reconnect the Negative (-) terminal to the battery.

**Tightening Torque:**

lb-ft	3.7
lb-in	44.4
N.m	5

7. Reinstall all parts in the reverse order of the removal process.
8. Check for any diagnostic trouble codes (DTC) and erase any DTC(s) present.

Confirm no DTC(s) return after being erased.